

### GENERAL DESCRIPTION

The 8533I-01 is a low skew, high performance 1-to-4 Differential-to-3.3V LVPECL Fanout Buffer. The 8533I-01 has two selectable clock inputs. The CLK, nCLK pair can accept most standard differential input levels. The PCLK, nPCLK pair can accept LVPECL, CML, or SSTL input levels. The clock enable is internally synchronized to eliminate runt pulses on the outputs during asynchronous assertion/deassertion of the clock enable pin.

Guaranteed output and part-to-part skew characteristics make the 8533I-01 ideal for those applications demanding well defined performance and repeatability.

### FEATURES

- Four differential 3.3V LVPECL outputs
- Selectable differential CLK, nCLK or LVPECL clock inputs
- CLK, nCLK pair can accept the following differential input levels: LVDS, LVPECL, LVHSTL, SSTL, HCSL
- PCLK, nPCLK supports the following input types: LVPECL, CML, SSTL
- Maximum output frequency: 650MHz
- Translates any single-ended input signal to 3.3V LVPECL levels with resistor bias on nCLK input
- Output skew: 30ps (maximum)
- Part-to-part skew: 150ps (maximum)
- Propagation delay: 1.5ns (maximum), CLK/nCLK
- Additive phase jitter, RMS: 0.060ps (typical)
- 3.3V operating supply
- -40°C to 85°C ambient operating temperature
- Available in lead-free (RoHS 6) package

### BLOCK DIAGRAM

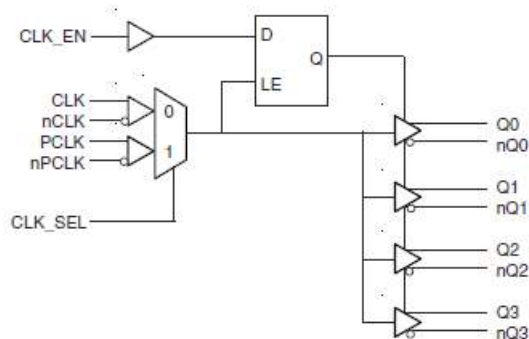

### PIN ASSIGNMENT

VEE	1	20	Q0
CLK_EN	2	19	nQ0
CLK_SEL	3	18	Vcc
CLK	4	17	Q1
nCLK	5	16	nQ1
PCLK	6	15	Q2
nPCLK	7	14	nQ2
nc	8	13	Vcc
nc	9	12	Q3
Vcc	10	11	nQ3

**8533I-01**  
**20-Lead TSSOP**  
 6.5mm x 4.4mm x 0.92mm package body  
**G Package**  
 Top View

**TABLE 1. PIN DESCRIPTIONS**

Number	Name	Type		Description
1	V <sub>EE</sub>	Power		Negative supply pin.
2	CLK_EN	Input	Pullup	Synchronizing clock enable. When HIGH, clock outputs follow clock input. When LOW, Q outputs are forced low, nQ outputs are forced high. LVCMOS / LVTTTL interface levels.
3	CLK_SEL	Input	Pulldown	Clock select input. When HIGH, selects differential PCLK, nPCLK inputs. When LOW, selects CLK, nCLK inputs. LVCMOS / LVTTTL interface levels.
4	CLK	Input	Pulldown	Non-inverting differential clock input.
5	nCLK	Input	Pullup	Inverting differential clock input.
6	PCLK	Input	Pulldown	Non-inverting differential LVPECL clock input.
7	nPCLK	Input	Pullup	Inverting differential LVPECL clock input.
8, 9	nc	Unused		No connect.
10, 13, 18	V <sub>CC</sub>	Power		Positive supply pins.
11, 12	nQ3, Q3	Output		Differential output pair. LVPECL interface levels.
14, 15	nQ2, Q2	Output		Differential output pair. LVPECL interface levels.
16, 17	nQ1, Q1	Output		Differential output pair. LVPECL interface levels.
19, 20	nQ0, Q0	Output		Differential output pair. LVPECL interface levels.

NOTE: *Pullup* and *Pulldown* refer to internal input resistors. See Table 2, Pin Characteristics, for typical values.

**TABLE 2. PIN CHARACTERISTICS**

Symbol	Parameter	Test Conditions	Minimum	Typical	Maximum	Units
C <sub>IN</sub>	Input Capacitance			4		pF
R <sub>PULLUP</sub>	Input Pullup Resistor			51		kΩ
R <sub>PULLDOWN</sub>	Input Pulldown Resistor			51		kΩ

**TABLE 3A. CONTROL INPUT FUNCTION TABLE**

Inputs			Outputs	
CLK_EN	CLK_SEL	Selected Source	Q0:Q3	nQ0:nQ3
0	0	CLK, nCLK	Disabled; LOW	Disabled; HIGH
0	1	PCLK, nPCLK	Disabled; LOW	Disabled; HIGH
1	0	CLK, nCLK	Enabled	Enabled
1	1	PCLK, nPCLK	Enabled	Enabled

After CLK\_EN switches, the clock outputs are disabled or enabled following a rising and falling input clock edge as shown in Figure 1. In the active mode, the state of the outputs are a function of the CLK, nCLK and PCLK, nPCLK inputs as described in Table 3B.

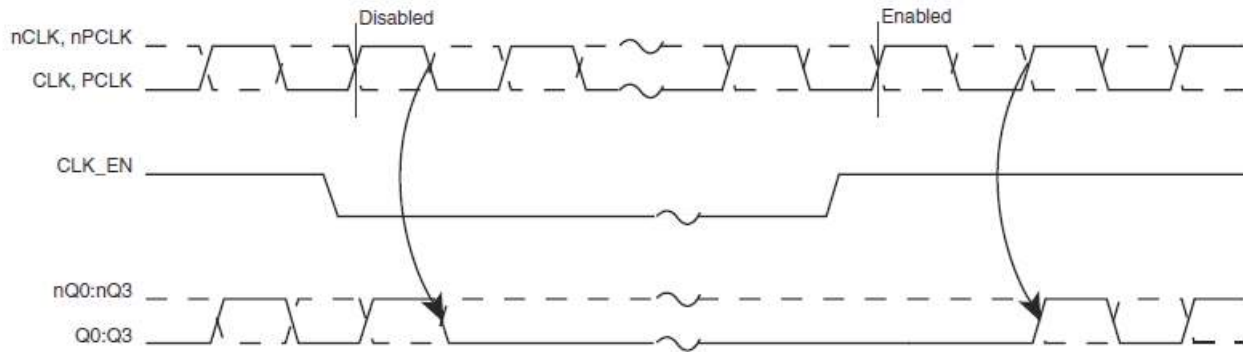

**FIGURE 1. CLK\_EN TIMING DIAGRAM**

**TABLE 3B. CLOCK INPUT FUNCTION TABLE**

Inputs		Outputs		Input to Output Mode	Polarity
CLK or PCLK	nCLK or nPCLK	Q0:Q3	nQ0:nQ3		
0	1	LOW	HIGH	Differential to Differential	Non Inverting
1	0	HIGH	LOW	Differential to Differential	Non Inverting
0	Biased; NOTE 1	LOW	HIGH	Single Ended to Differential	Non Inverting
1	Biased; NOTE 1	HIGH	LOW	Single Ended to Differential	Non Inverting
Biased; NOTE 1	0	HIGH	LOW	Single Ended to Differential	Inverting
Biased; NOTE 1	1	LOW	HIGH	Single Ended to Differential	Inverting

NOTE 1: Please refer to the Application Information section, "Wiring the Differential Input to Accept Single Ended Levels".

### ABSOLUTE MAXIMUM RATINGS

Supply Voltage, $V_{CC}$	4.6V
Inputs, $V_I$	-0.5V to $V_{CC} + 0.5V$
Outputs, $I_O$	
Continuous Current	50mA
Surge Current	100mA
Package Thermal Impedance, $\theta_{JA}$	73.2°C/W (0 lfpm)
Storage Temperature, $T_{STG}$	-65°C to 150°C

NOTE: Stresses beyond those listed under Absolute Maximum Ratings may cause permanent damage to the device. These ratings are stress specifications only. Functional operation of product at these conditions or any conditions beyond those listed in the *DC Characteristics* or *AC Characteristics* is not implied. Exposure to absolute maximum rating conditions for extended periods may affect product reliability.

**TABLE 4A. POWER SUPPLY DC CHARACTERISTICS,  $V_{CC} = 3.3V \pm 5\%$ ,  $T_A = -40^\circ C$  TO  $85^\circ C$**

Symbol	Parameter	Test Conditions	Minimum	Typical	Maximum	Units
$V_{CC}$	Positive Supply Voltage		3.135	3.3	3.465	V
$I_{EE}$	Power Supply Current				52	mA

**TABLE 4B. LVCMOS / LVTTTL DC CHARACTERISTICS,  $V_{CC} = 3.3V \pm 5\%$ ,  $T_A = -40^\circ C$  TO  $85^\circ C$**

Symbol	Parameter	Test Conditions	Minimum	Typical	Maximum	Units
$V_{IH}$	Input High Voltage		2		$V_{CC} + 0.3$	V
$V_{IL}$	Input Low Voltage		-0.3		0.8	V
$I_{IH}$	Input High Current	CLK_EN	$V_{IN} = V_{CC} = 3.465V$		5	$\mu A$
		CLK_SEL	$V_{IN} = V_{CC} = 3.465V$		150	$\mu A$
$I_{IL}$	Input Low Current	CLK_EN	$V_{IN} = 0V, V_{CC} = 3.465V$	-150		$\mu A$
		CLK_SEL	$V_{IN} = 0V, V_{CC} = 3.465V$	-5		$\mu A$

**TABLE 4C. DIFFERENTIAL DC CHARACTERISTICS,  $V_{CC} = 3.3V \pm 5\%$ ,  $T_A = -40^\circ C$  TO  $85^\circ C$**

Symbol	Parameter	Test Conditions	Minimum	Typical	Maximum	Units
$I_{IH}$	Input High Current	nCLK	$V_{CC} = V_{IN} = 3.465V$		5	$\mu A$
		CLK	$V_{CC} = V_{IN} = 3.465V$		150	$\mu A$
$I_{IL}$	Input Low Current	nCLK	$V_{CC} = 3.465V, V_{IN} = 0V$	-150		$\mu A$
		CLK	$V_{CC} = 3.465V, V_{IN} = 0V$	-5		$\mu A$
$V_{PP}$	Peak-to-Peak Input Voltage		0.15		1.3	V
$V_{CMR}$	Common Mode Input Voltage; NOTE 1, 2		$V_{EE} + 0.5$		$V_{CC} - 0.85$	V

NOTE 1: For single ended applications, the maximum input voltage for CLK and nCLK is  $V_{CC} + 0.3V$ .

NOTE 2: Common mode voltage is defined as  $V_{IH}$ .

**TABLE 4D. LVPECL DC CHARACTERISTICS,  $V_{CC} = 3.3V \pm 5\%$ ,  $T_A = -40^\circ C$  TO  $85^\circ C$** 

Symbol	Parameter	Test Conditions	Minimum	Typical	Maximum	Units
$I_{IH}$	Input High Current	PCLK	$V_{CC} = V_{IN} = 3.465V$		150	$\mu A$
		nPCLK	$V_{CC} = V_{IN} = 3.465V$		5	$\mu A$
$I_{IL}$	Input Low Current	PCLK	$V_{CC} = 3.465V, V_{IN} = 0V$	-5		$\mu A$
		nPCLK	$V_{CC} = 3.465V, V_{IN} = 0V$	-150		$\mu A$
$V_{PP}$	Peak-to-Peak Input Voltage		0.3		1	V
$V_{CMR}$	Common Mode Input Voltage; NOTE 1, 2		$V_{EE} + 1.5$		$V_{CC}$	V
$V_{OH}$	Output High Voltage; NOTE 3		$V_{CC} - 1.4$		$V_{CC} - 0.9$	V
$V_{OL}$	Output Low Voltage; NOTE 3		$V_{CC} - 2.0$		$V_{CC} - 1.7$	V
$V_{SWING}$	Peak-to-Peak Output Voltage Swing		0.6		1.0	V

NOTE 1: Common mode voltage is defined as  $V_{IH}$ .

NOTE 2: For single ended applications the maximum input voltage for PCLK and nPCLK is  $V_{CC} + 0.3V$ .

NOTE 3: Outputs terminated with  $50\Omega$  to  $V_{CC} - 2V$ .

**TABLE 5. AC CHARACTERISTICS,  $V_{CC} = 3.3V \pm 5\%$ ,  $T_A = -40^\circ C$  TO  $85^\circ C$** 

Symbol	Parameter	Test Conditions	Minimum	Typical	Maximum	Units
$f_{MAX}$	Output Frequency				650	MHz
$t_{PD}$	Propagation Delay; NOTE 1	CLK, nCLK	1.15		1.5	ns
		PCLK, nPCLK	1.0		1.3	ns
tsk(o)	Output Skew; NOTE 2, 4				30	ps
tsk(pp)	Part-to-Part Skew; NOTE 3, 4				150	ps
tjit	Buffer Additive Phase Jitter, RMS; refer to Additive Phase Jitter section			0.060		ps
$t_R / t_F$	Output Rise/Fall Time		300		800	ps
odc	Output Duty Cycle		47		53	%

All parameters measured at  $f \leq 650MHz$  unless noted otherwise.

The cycle to cycle jitter on the input will equal the jitter on the output. The part does not add jitter.

NOTE 1: Measured from the differential input crossing point to the differential output crossing point.

NOTE 2: Defined as skew between outputs at the same supply voltage and with equal load conditions.

Measured at output differential cross points.

NOTE 3: Defined as skew between outputs on different devices operating at the same supply voltages and with equal load conditions. Using the same type of inputs on each device, the outputs are measured at the differential cross points.

NOTE 4: This parameter is defined in accordance with JEDEC Standard 65.

## ADDITIVE PHASE JITTER

The spectral purity in a band at a specific offset from the fundamental compared to the power of the fundamental is called the **dBc Phase Noise**. This value is normally expressed using a Phase noise plot and is most often the specified plot in many applications. Phase noise is defined as the ratio of the noise power present in a 1Hz band at a specified offset from the fundamental frequency to the power value of the fundamental. This ratio is expressed in decibels (dBm) or a ratio of the power in

the 1Hz band to the power in the fundamental. When the required offset is specified, the phase noise is called a **dBc** value, which simply means dBm at a specified offset from the fundamental. By investigating jitter in the frequency domain, we get a better understanding of its effects on the desired application over the entire time record of the signal. It is mathematically possible to calculate an expected bit error rate given a phase noise plot.

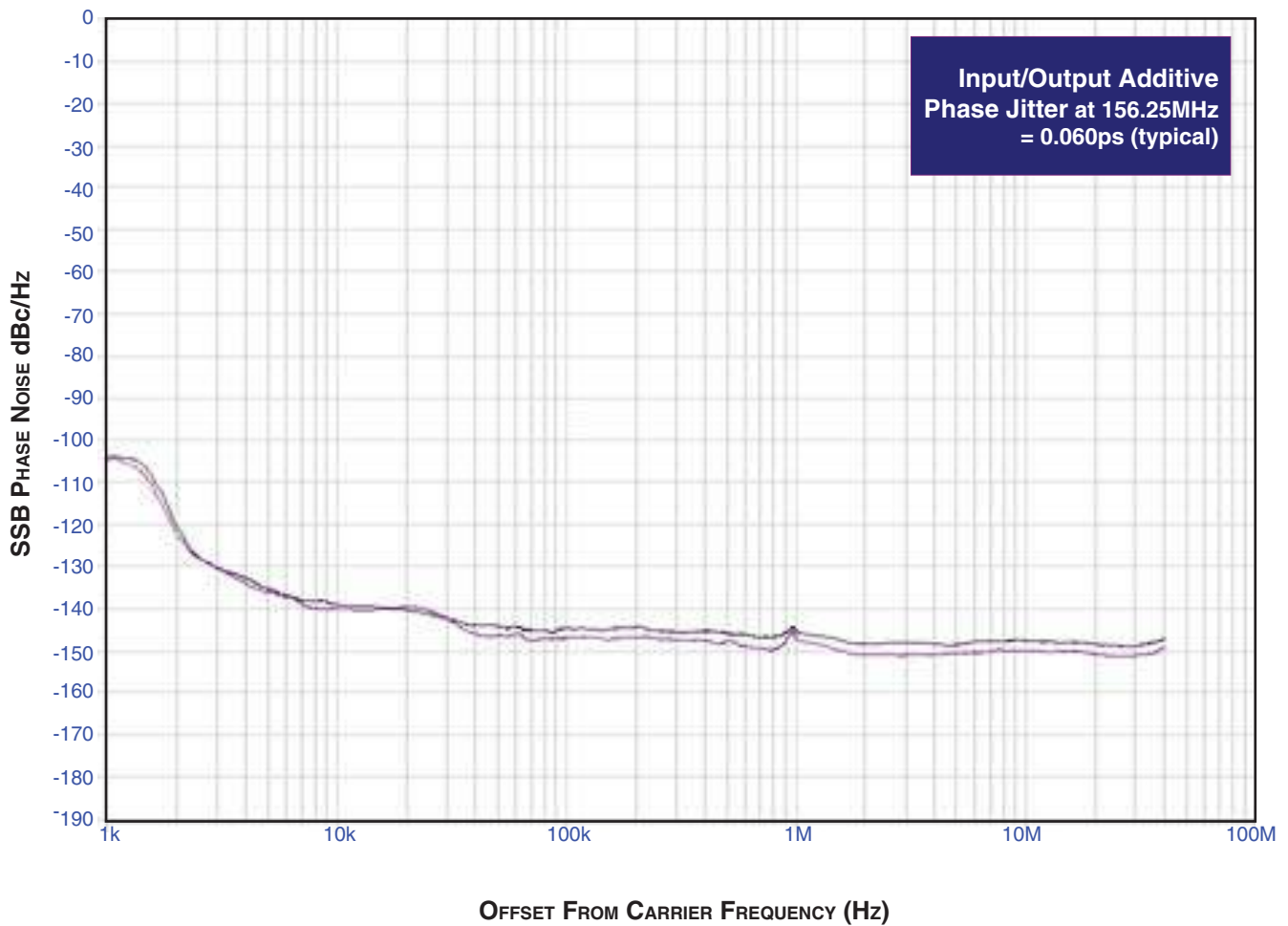

As with most timing specifications, phase noise measurements have issues. The primary issue relates to the limitations of the equipment. Often the noise floor of the equipment is higher than the noise floor of the device. This is illustrated above. The

device meets the noise floor of what is shown, but can actually be lower. The phase noise is dependent on the input source and measurement equipment.

# PARAMETER MEASUREMENT INFORMATION

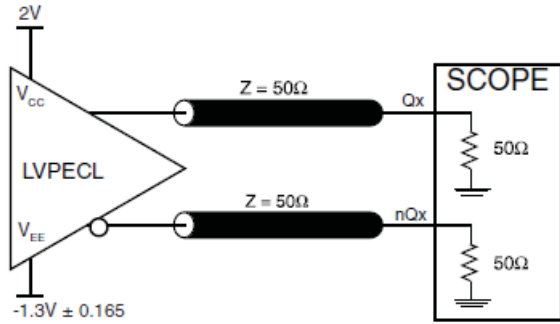

3.3V OUTPUT LOAD AC TEST CIRCUIT

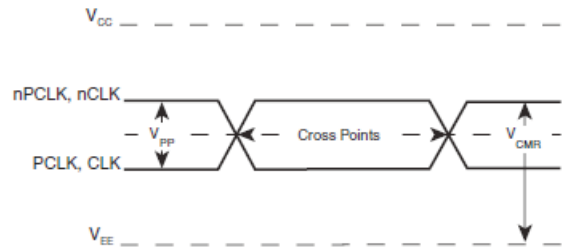

DIFFERENTIAL INPUT LEVEL

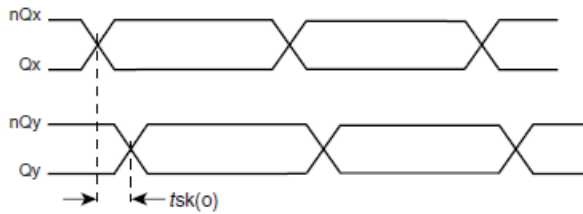

OUTPUT SKEW

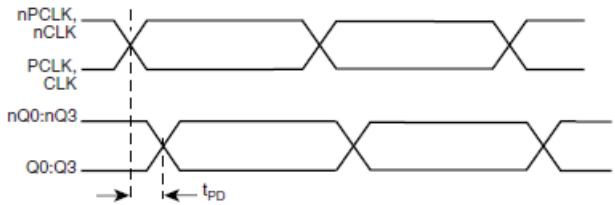

PROPAGATION DELAY

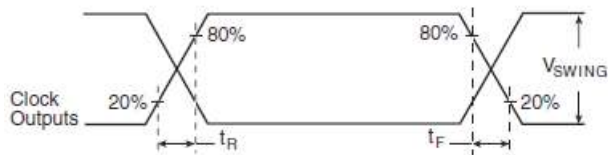

OUTPUT RISE/FALL TIME

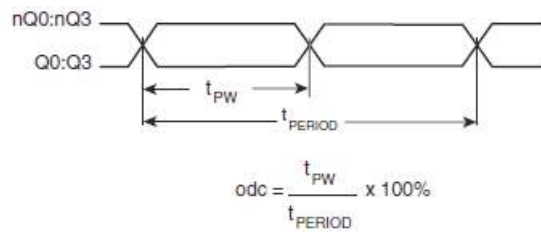

OUTPUT DUTY CYCLE/PULSE WIDTH/PERIOD

## APPLICATION INFORMATION

### WIRING THE DIFFERENTIAL INPUT TO ACCEPT SINGLE ENDED LEVELS

Figure 2 shows how the differential input can be wired to accept single ended levels. The reference voltage  $V_{REF} = V_{CC}/2$  is generated by the bias resistors R1, R2 and C1. This bias circuit should be located as close as possible to the input pin. The ratio

of R1 and R2 might need to be adjusted to position the  $V_{REF}$  in the center of the input voltage swing. For example, if the input clock swing is only 2.5V and  $V_{CC} = 3.3V$ ,  $V_{REF}$  should be 1.25V and  $R2/R1 = 0.609$ .

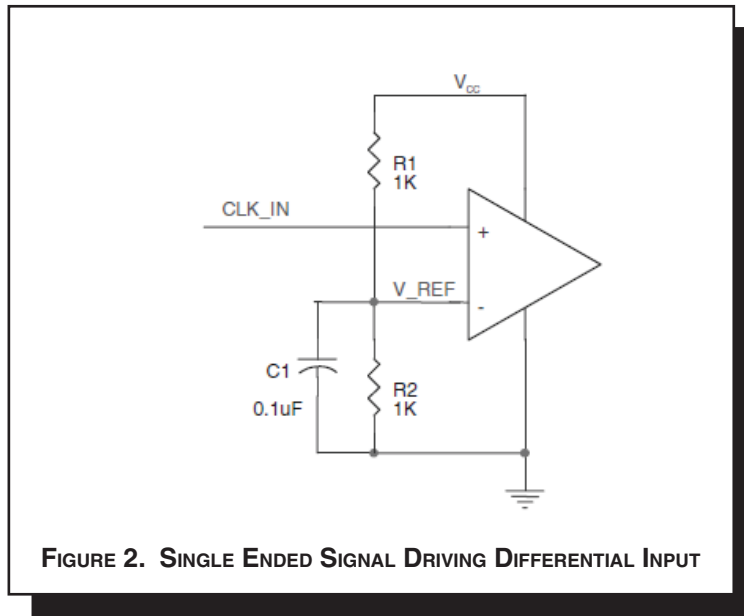

FIGURE 2. SINGLE ENDED SIGNAL DRIVING DIFFERENTIAL INPUT

### RECOMMENDATIONS FOR UNUSED INPUT AND OUTPUT PINS

#### INPUTS:

##### CLK/nCLK INPUT:

For applications not requiring the use of the differential input, both CLK and nCLK can be left floating. Though not required, but for additional protection, a 1kΩ resistor can be tied from CLK to ground.

##### PCLK/nPCLK INPUT:

For applications not requiring the use of a differential input, both the PCLK and nPCLK pins can be left floating. Though not required, but for additional protection, a 1kΩ resistor can be tied from PCLK to ground.

##### LVC MOS CONTROL PINS:

All control pins have internal pull-ups or pull-downs; additional resistance is not required but can be added for additional protection. A 1kΩ resistor can be used.

#### OUTPUTS:

##### LVPECL OUTPUT

All unused LVPECL outputs can be left floating. We recommend that there is no trace attached. Both sides of the differential output pair should either be left floating or terminated.



### DIFFERENTIAL CLOCK INPUT INTERFACE

The CLK /nCLK accepts LVDS, LVPECL, LVHSTL, SSTL, HCSL and other differential signals. Both  $V_{SWING}$  and  $V_{OH}$  must meet the  $V_{PP}$  and  $V_{CMR}$  input requirements. Figures 3A to 3E show interface examples for the HiPerClockS CLK/nCLK input driven by the most common driver types. The input interfaces suggested here are examples only. Please consult with the

vendor of the driver component to confirm the driver termination requirements. For example in *Figure 3A*, the input termination applies for ICS HiPerClockS LVHSTL drivers. If you are using an LVHSTL driver from another vendor, use their termination recommendation.

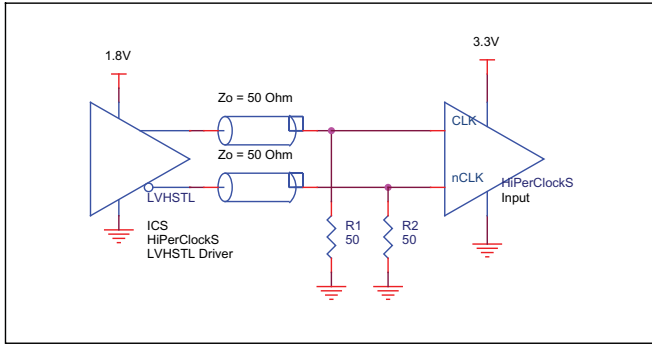

**FIGURE 3A. HiPerClockS CLK/nCLK INPUT DRIVEN BY ICS HiPerClockS LVHSTL DRIVER**

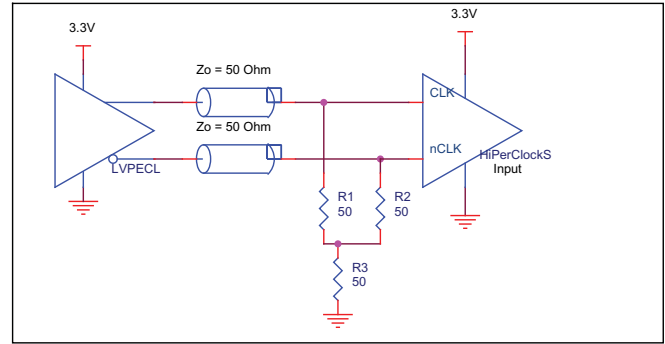

**FIGURE 3B. HiPerClockS CLK/nCLK INPUT DRIVEN BY 3.3V LVPECL DRIVER**

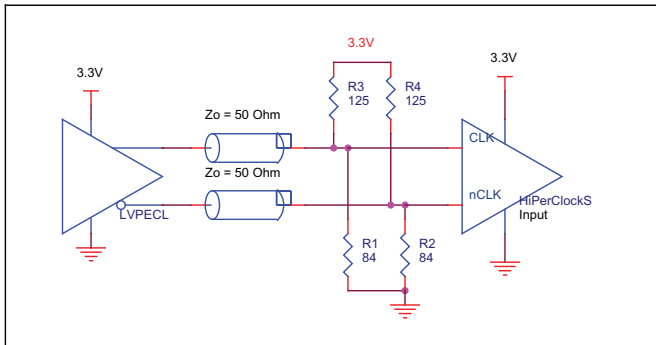

**FIGURE 3C. HiPerClockS CLK/nCLK INPUT DRIVEN BY 3.3V LVPECL DRIVER**

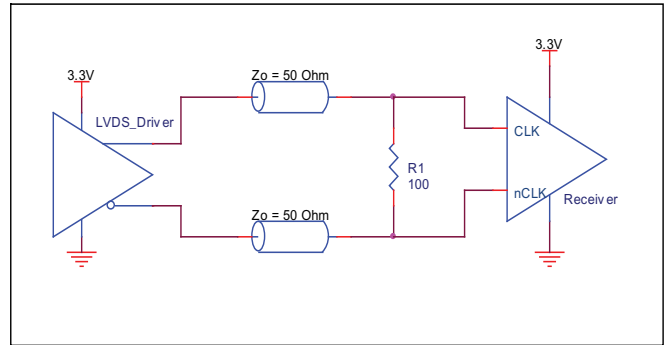

**FIGURE 3D. HiPerClockS CLK/nCLK INPUT DRIVEN BY 3.3V LVDS DRIVER**

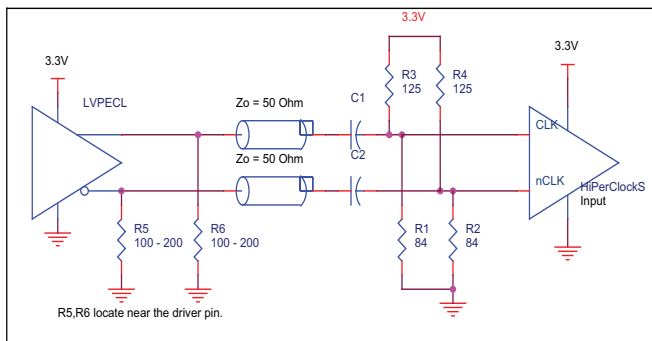

**FIGURE 3E. HiPerClockS CLK/nCLK INPUT DRIVEN BY 3.3V LVPECL DRIVER WITH AC COUPLE**

### LVPECL CLOCK INPUT INTERFACE

The PCLK/nPCLK accepts LVPECL, CML, SSTL and other differential signals. Both  $V_{SWING}$  and  $V_{OH}$  must meet the  $V_{PP}$  and  $V_{CMR}$  input requirements. Figures 4A to 4F show interface examples for the HiPerClockS PCLK/nPCLK input driven by the most common driver types. The input interfaces suggested here are examples

only. If the driver is from another vendor, use their termination recommendation. Please consult with the vendor of the driver component to confirm the driver termination requirements.

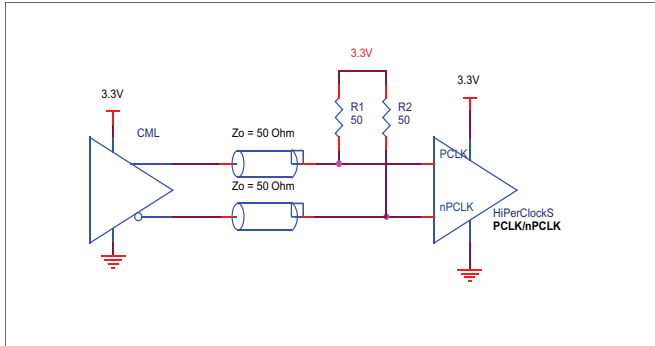

FIGURE 4A. HiPerClockS PCLK/nPCLK INPUT DRIVEN BY AN OPEN COLLECTOR CML DRIVER

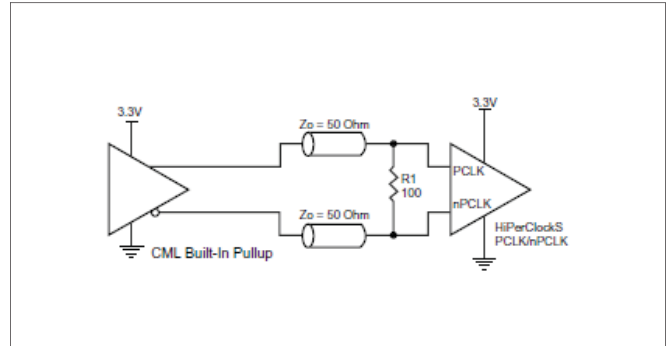

FIGURE 4B. HiPerClockS PCLK/nPCLK INPUT DRIVEN BY A BUILT-IN PULLUP CML DRIVER

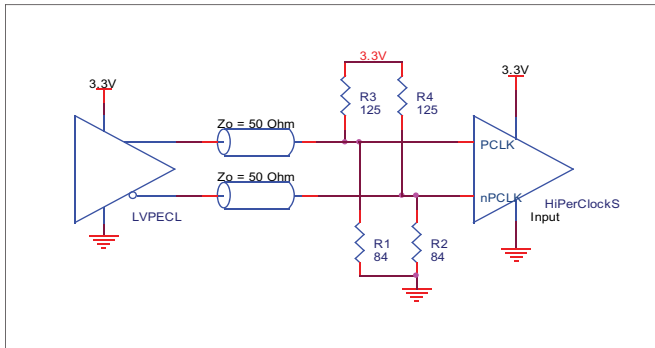

FIGURE 4C. HiPerClockS PCLK/nPCLK INPUT DRIVEN BY A 3.3V LVPECL DRIVER

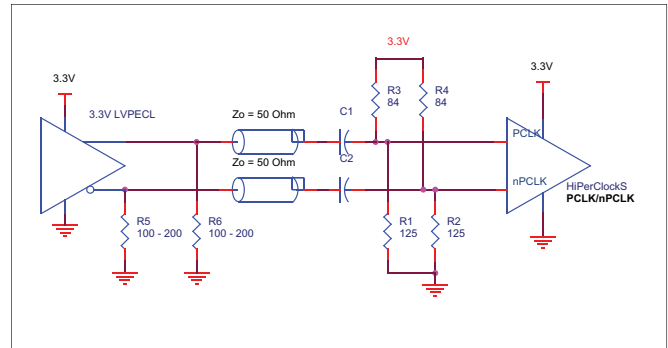

FIGURE 4D. HiPerClockS PCLK/nPCLK INPUT DRIVEN BY A 3.3V LVPECL DRIVER WITH AC COUPLE

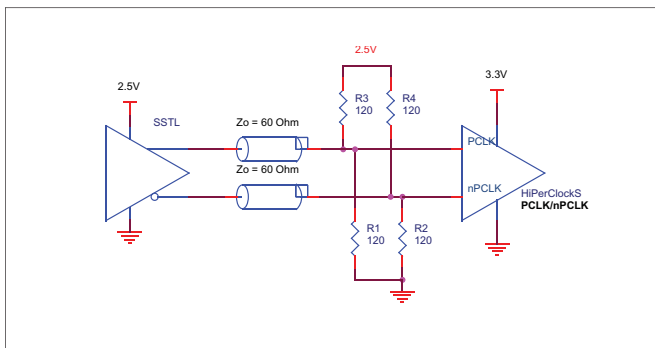

FIGURE 4E. HiPerClockS PCLK/nPCLK INPUT DRIVEN BY AN SSTL DRIVER

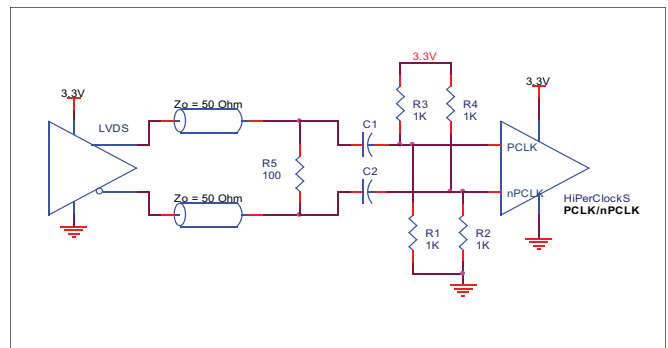

FIGURE 4F. HiPerClockS PCLK/nPCLK INPUT DRIVEN BY A 3.3V LVDS DRIVER

### TERMINATION FOR LVPECL OUTPUTS

The clock layout topology shown below is a typical termination for LVPECL outputs. The two different layouts mentioned are recommended only as guidelines.

FOUT and nFOUT are low impedance follower outputs that generate ECL/LVPECL compatible outputs. Therefore, terminating resistors (DC current path to ground) or current sources must be used for functionality. These outputs are designed to drive 50Ω transmission lines. Matched impedance

techniques should be used to maximize operating frequency and minimize signal distortion. *Figures 5A and 5B* show two different layouts which are recommended only as guidelines. Other suitable clock layouts may exist and it would be recommended that the board designers simulate to guarantee compatibility across all printed circuit and clock component process variations.

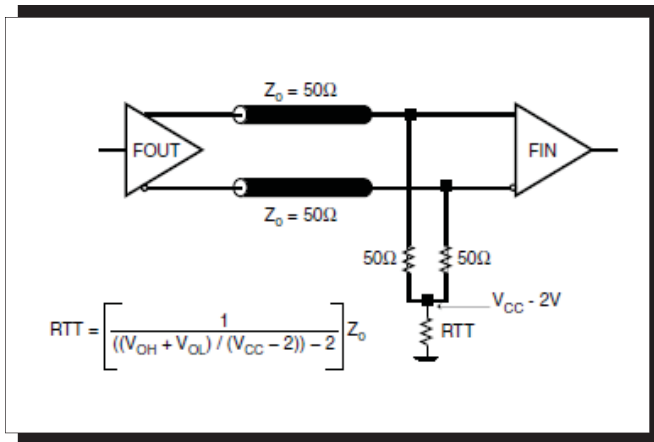

FIGURE 5A. LVPECL OUTPUT TERMINATION

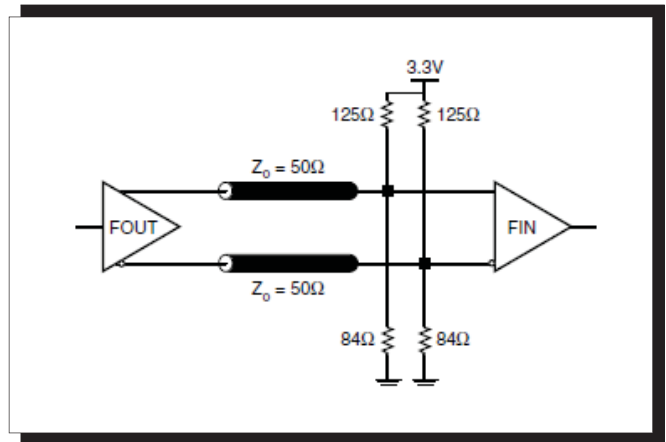

FIGURE 5B. LVPECL OUTPUT TERMINATION

## POWER CONSIDERATIONS

This section provides information on power dissipation and junction temperature for the 8533I-01. Equations and example calculations are also provided.

### 1. Power Dissipation.

The total power dissipation for the 8533I-01 is the sum of the core power plus the power dissipated in the load(s). The following is the power dissipation for  $V_{CC} = 3.3V + 5\% = 3.465V$ , which gives worst case results.

**NOTE:** Please refer to Section 3 for details on calculating power dissipated in the load.

- Power (core)<sub>MAX</sub> =  $V_{CC\_MAX} * I_{EE\_MAX} = 3.465V * 52mA = 180.2mW$
- Power (outputs)<sub>MAX</sub> = **30mW/Loaded Output pair**  
If all outputs are loaded, the total power is  $4 * 30mW = 120mW$

**Total Power**<sub>MAX</sub> (3.465V, with all outputs switching) =  $180.2mW + 120mW = 300.2mW$

### 2. Junction Temperature.

Junction temperature, T<sub>j</sub>, is the temperature at the junction of the bond wire and bond pad and directly affects the reliability of the device. The maximum recommended junction temperature for HiPerClockS™ devices is 125°C.

The equation for T<sub>j</sub> is as follows:  $T_j = \theta_{JA} * Pd\_total + T_A$

T<sub>j</sub> = Junction Temperature

$\theta_{JA}$  = Junction-to-Ambient Thermal Resistance

Pd<sub>total</sub> = Total Device Power Dissipation (example calculation is in section 1 above)

T<sub>A</sub> = Ambient Temperature

In order to calculate junction temperature, the appropriate junction-to-ambient thermal resistance  $\theta_{JA}$  must be used. Assuming a moderate air flow of 200 linear feet per minute and a multi-layer board, the appropriate value is 66.6°C/W per Table 6 below.

Therefore, T<sub>j</sub> for an ambient temperature of 85°C with all outputs switching is:

$$85^\circ C + 0.300W * 66.6^\circ C/W = 105^\circ C. \text{ This is well below the limit of } 125^\circ C.$$

This calculation is only an example. T<sub>j</sub> will obviously vary depending on the number of loaded outputs, supply voltage, air flow, and the type of board (single layer or multi-layer).

**TABLE 6. THERMAL RESISTANCE  $\theta_{JA}$  FOR 20-PIN TSSOP, FORCED CONVECTION**

<b><math>\theta_{JA}</math> by Velocity (Linear Feet per Minute)</b>			
	<b>0</b>	<b>200</b>	<b>500</b>
Single-Layer PCB, JEDEC Standard Test Boards	114.5°C/W	98.0°C/W	88.0°C/W
Multi-Layer PCB, JEDEC Standard Test Boards	73.2°C/W	66.6°C/W	63.5°C/W

**NOTE:** Most modern PCB designs use multi-layered boards. The data in the second row pertains to most designs.

3. Calculations and Equations.

The purpose of this section is to derive the power dissipated into the load.

LVPECL output driver circuit and termination are shown in Figure 6.

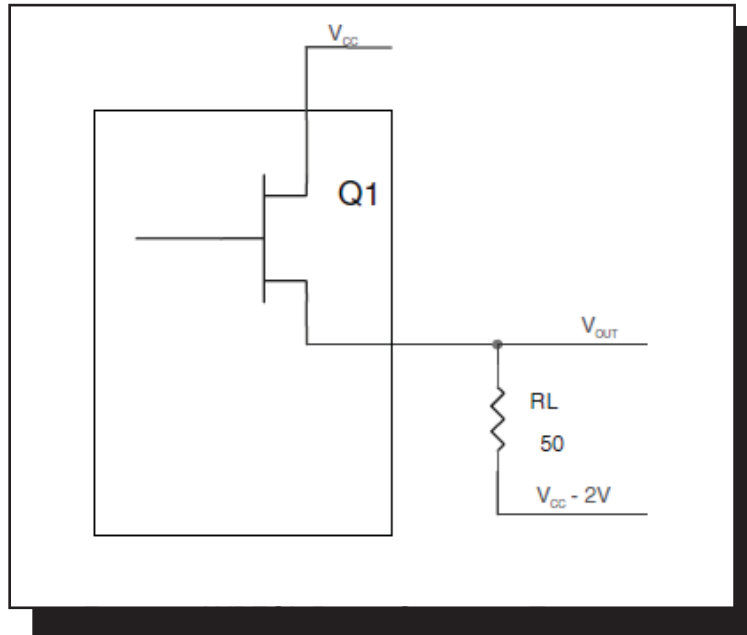

To calculate worst case power dissipation into the load, use the following equations which assume a 50Ω load, and a termination voltage of  $V_{CC} - 2V$ .

- For logic high,  $V_{OUT} = V_{OH\_MAX} = V_{CC\_MAX} - 0.9V$

$$(V_{CC\_MAX} - V_{OH\_MAX}) = 0.9V$$

- For logic low,  $V_{OUT} = V_{OL\_MAX} = V_{CC\_MAX} - 1.7V$

$$(V_{CC\_MAX} - V_{OL\_MAX}) = 1.7V$$

$Pd\_H$  is power dissipation when the output drives high.  
 $Pd\_L$  is the power dissipation when the output drives low.

$$Pd\_H = [(V_{OH\_MAX} - (V_{CC\_MAX} - 2V))/R_L] * (V_{CC\_MAX} - V_{OH\_MAX}) = [(2V - (V_{CC\_MAX} - V_{OH\_MAX}))/R_L] * (V_{CC\_MAX} - V_{OH\_MAX}) = [(2V - 0.9V)/50\Omega] * 0.9V = 19.8mW$$

$$Pd\_L = [(V_{OL\_MAX} - (V_{CC\_MAX} - 2V))/R_L] * (V_{CC\_MAX} - V_{OL\_MAX}) = [(2V - (V_{CC\_MAX} - V_{OL\_MAX}))/R_L] * (V_{CC\_MAX} - V_{OL\_MAX}) = [(2V - 1.7V)/50\Omega] * 1.7V = 10.2mW$$

Total Power Dissipation per output pair =  $Pd\_H + Pd\_L = 30mW$

## RELIABILITY INFORMATION

TABLE 7.  $\theta_{JA}$  VS. AIR FLOW TABLE FOR 20 LEAD TSSOP

$\theta_{JA}$ by Velocity (Linear Feet per Minute)			
	0	200	500
Single-Layer PCB, JEDEC Standard Test Boards	114.5°C/W	98.0°C/W	88.0°C/W
Multi-Layer PCB, JEDEC Standard Test Boards	73.2°C/W	66.6°C/W	63.5°C/W

**NOTE:** Most modern PCB designs use multi-layered boards. The data in the second row pertains to most designs.

### TRANSISTOR COUNT

The transistor count for 8533I-01 is: 404

PACKAGE OUTLINE - G SUFFIX FOR 20 LEAD TSSOP

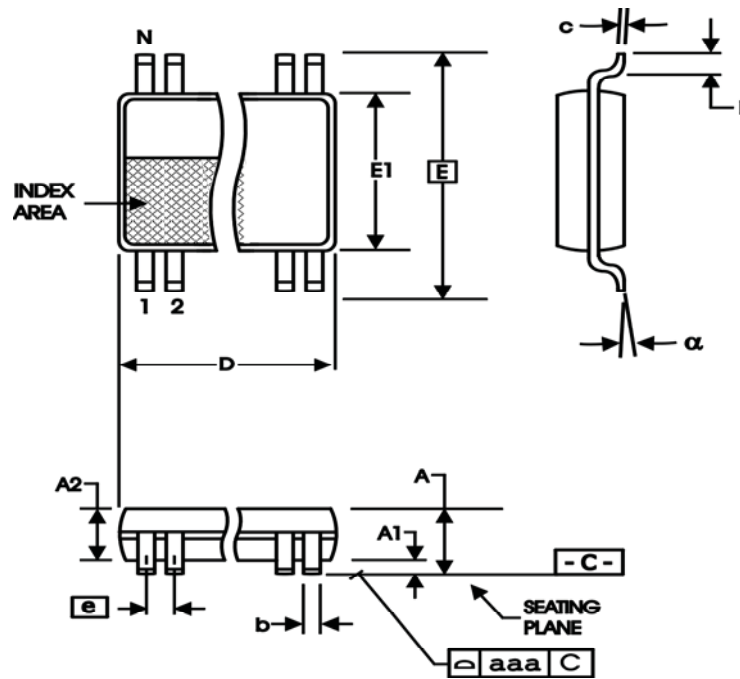

TABLE 8. PACKAGE DIMENSIONS

SYMBOL	Millimeters	
	Minimum	Maximum
N	20	
A	--	1.20
A1	0.05	0.15
A2	0.80	1.05
b	0.19	0.30
c	0.09	0.20
D	6.40	6.60
E	6.40 BASIC	
E1	4.30	4.50
e	0.65 BASIC	
L	0.45	0.75
$\alpha$	0°	8°
aaa	--	0.10

Reference Document: JEDEC Publication 95, MS-153

**TABLE 9. ORDERING INFORMATION**

Part/Order Number	Marking	Package	Shipping Packaging	Temperature
8533AGI-01LF	8533AI01L	20 lead "Lead Free" TSSOP	tube	-40°C to 85°C
8533AGI-01LFT	8533AI01L	20 lead "Lead Free" TSSOP	tape & reel	-40°C to 85°C

NOTE: Parts that are ordered with an "LF" suffix to the part number are the Pb-Free configuration and are RoHS compliant.



REVISION HISTORY SHEET				
Rev	Table	Page	Description of Change	Date
A	T9	1	Features Section - added lead-free note.	4/21/06
		8	Added Recommendations for Unused Input and Output Pins.	
		10	Updated LVPECL Clock Input Interface.	
		16	Ordering Information Table - added lead-free part number, marking and note.	
A	T9	16	Ordering Information Table - Changed non lead free marking	12-6-07
A	T9	16	Ordering Information Table - removed leaded devices. Updated data sheet format.	7/9/15



## IMPORTANT NOTICE AND DISCLAIMER

RENESAS ELECTRONICS CORPORATION AND ITS SUBSIDIARIES (“RENESAS”) PROVIDES TECHNICAL SPECIFICATIONS AND RELIABILITY DATA (INCLUDING DATASHEETS), DESIGN RESOURCES (INCLUDING REFERENCE DESIGNS), APPLICATION OR OTHER DESIGN ADVICE, WEB TOOLS, SAFETY INFORMATION, AND OTHER RESOURCES “AS IS” AND WITH ALL FAULTS, AND DISCLAIMS ALL WARRANTIES, EXPRESS OR IMPLIED, INCLUDING, WITHOUT LIMITATION, ANY IMPLIED WARRANTIES OF MERCHANTABILITY, FITNESS FOR A PARTICULAR PURPOSE, OR NON-INFRINGEMENT OF THIRD PARTY INTELLECTUAL PROPERTY RIGHTS.

These resources are intended for developers skilled in the art designing with Renesas products. You are solely responsible for (1) selecting the appropriate products for your application, (2) designing, validating, and testing your application, and (3) ensuring your application meets applicable standards, and any other safety, security, or other requirements. These resources are subject to change without notice. Renesas grants you permission to use these resources only for development of an application that uses Renesas products. Other reproduction or use of these resources is strictly prohibited. No license is granted to any other Renesas intellectual property or to any third party intellectual property. Renesas disclaims responsibility for, and you will fully indemnify Renesas and its representatives against, any claims, damages, costs, losses, or liabilities arising out of your use of these resources. Renesas' products are provided only subject to Renesas' Terms and Conditions of Sale or other applicable terms agreed to in writing. No use of any Renesas resources expands or otherwise alters any applicable warranties or warranty disclaimers for these products.

(Disclaimer Rev.1.0 Mar 2020)

### Corporate Headquarters

TOYOSU FORESIA, 3-2-24 Toyosu,  
Koto-ku, Tokyo 135-0061, Japan  
[www.renesas.com](http://www.renesas.com)

### Contact Information

For further information on a product, technology, the most up-to-date version of a document, or your nearest sales office, please visit:  
[www.renesas.com/contact/](http://www.renesas.com/contact/)

### Trademarks

Renesas and the Renesas logo are trademarks of Renesas Electronics Corporation. All trademarks and registered trademarks are the property of their respective owners.