



# Realtek Ameba RTL8195AM DEV01 User Manual

---

This document define pin out of Ameba RTL8195AM DEV.

Version 1.10

---

## Table of Contents

1	System requirements .....	3
2	Hardware block diagram.....	3
3	Pin out reference .....	4
4	Antenna hardware setup.....	5
5	Peripherals support.....	6
5.1	Pin function table setup.....	6
5.2	Peripheral Descriptions .....	7
6	Hardware configuration .....	8
6.1	CMSIS-DAP .....	8
6.2	J-Link/JTAG .....	9
6.3	DAP mode.....	11
7	Reference electrical schematics .....	12
8	Sensor board.....	14

# 1 System requirements

- Windows PC (XP, Vista, 7)
- USB type A to Micro-B USB cable x 1
- RS-232 to UART board(debug) x 1, JTAG cable x1 (option)

# 2 Hardware block diagram

- IC: RTL8195AM
- Module HDK version: HDK-AM95A03\_1V0
- DEV HDK version: RTL-AMEBA\_DEV01\_1v1

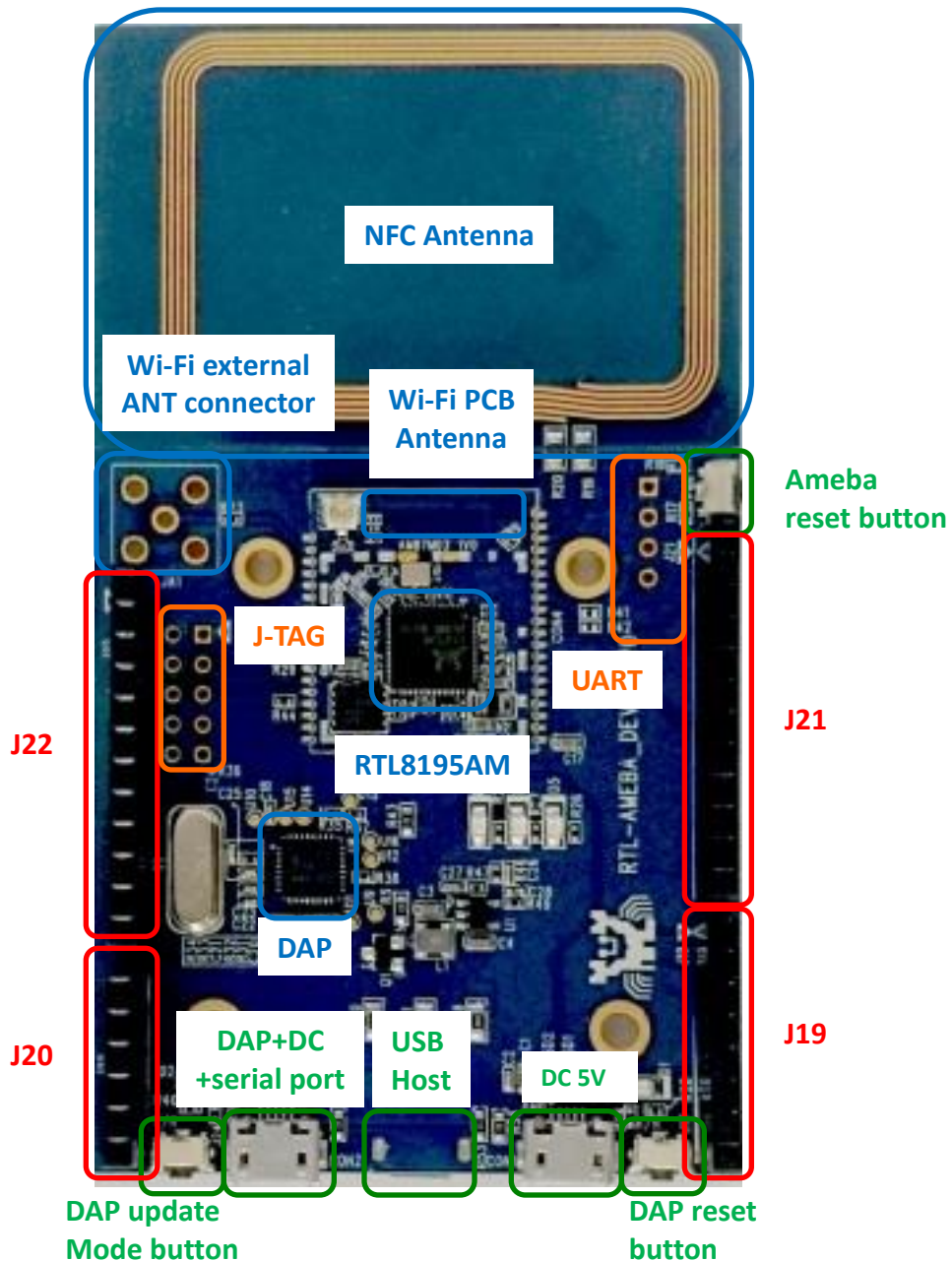



## 4 Antenna hardware setup

- I-PEX/U.FL connector: R206
- External antenna: R207
- PCB antenna: R208

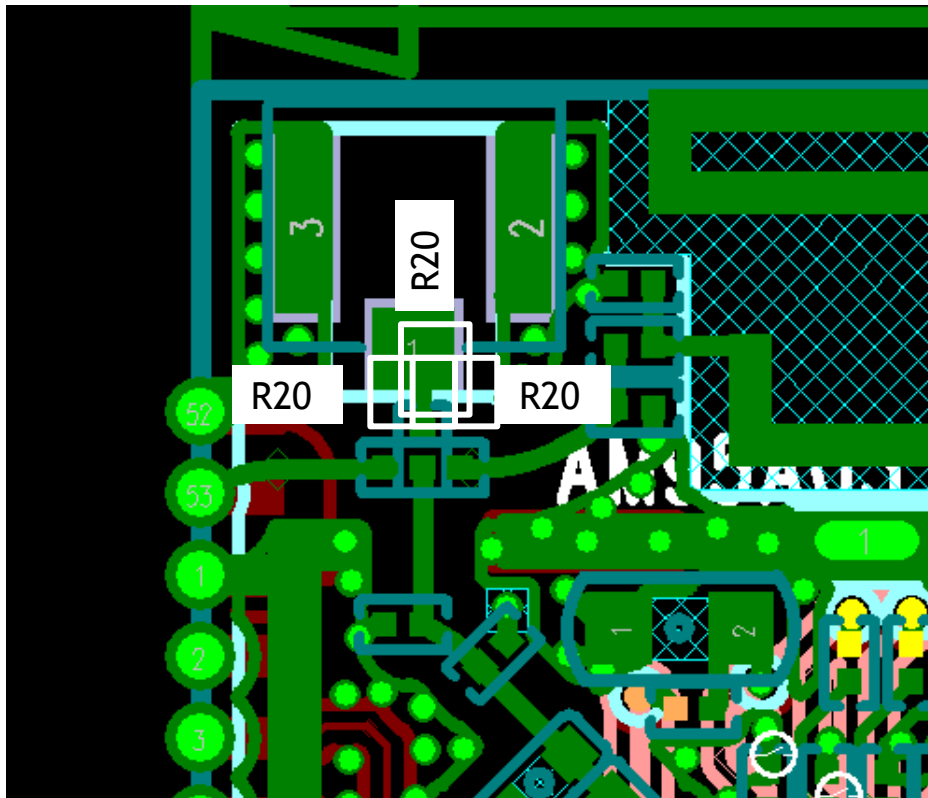
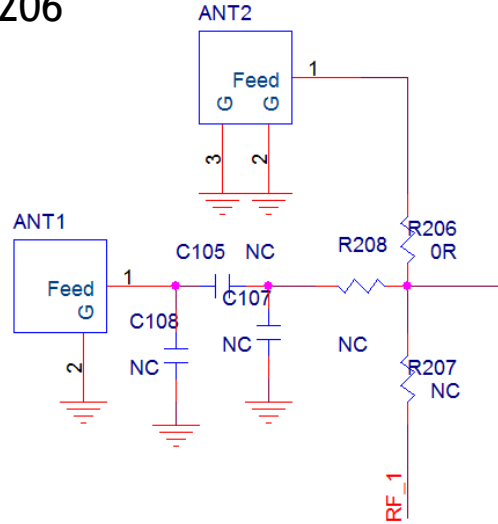

## 5 Peripherals support

- Debug UART: GPIOB\_[0..1]
- JTAG: GPIOE\_[0..4]

### 5.1 Pin function table setup

- Multiple functions are supported by group setup.
- For example: GPIOA\_6(Rx), GPIOA\_7(Tx), GPIOA\_3(RTS) and GPIOA\_5(CTS) are used if UART0 function. GPIOA\_3(RTS) and GPIOA\_5(CTS) can not be used as other functions.
- For example: GPIOC\_0, GPIOC\_1, GPIOC\_2, GPIOC\_2, GPIOC\_3 are used if PWM is occupied. GPIOC\_1(PWM1) and GPIOC\_2(PWM2) can not be used as other functions.

PIN name	JTAG	SDD	SDH	MII	UART Group	I2C Group	SPI Group	I2S Group	PCM Group	WL_LED	PWM	ETE	WKDT	GPIO INT	Default State	SCHMT
GPIOA_0		D2	D2	RX_CK	UART2_IN		SPI1_MISO							GPIO_INT	PH	0
GPIOA_1		D3	D3	RXD0	UART2_CTS		SPI1_MOSI							GPIO_INT	HI	
GPIOA_2		CMD	CMD	RXD1	UART2_RTS		SPI1_CLK								PH	0
GPIOA_3		CLK	CLK	RXD2	UART0_RTS										PH	0
GPIOA_4		D0	D0	RXD3	UART2_OUT		SPI1_CS								PH	
GPIOA_5		D1	D1	RXDV	UART0_CTS								D_SBY0		PH	
GPIOA_6		INT	CD	RXERR	UART0_IN										PH	
GPIOA_7			WP	COL	UART0_OUT										HI	
GPIOB_0					LOG_OUT							ETE0	D_SLPO		HI	
GPIOB_1					LOG_IN					WL_LED0		ETE1			PH	
GPIOB_2						I2C3_SCL						ETE2			HI	0
GPIOB_3						I2C3_SDA						ETE3		GPIO_INT	PH	
GPIOB_4										WL_LED0	PWM0			GPIO_INT	PH	
GPIOB_5										WL_LED0	PWM1				PH	0
GPIOC_0				TXD2	UART0_IN		SPIO_CS0	I2S1_WS	PCM1_SYNC		PWM0	ETE0			HI	
GPIOC_1				TXD1	UART0_CTS		SPIO_CLK	I2S1_CLK	PCM1_CLK		PWM1	ETE1		GPIO_INT	HI	0
GPIOC_2				TXD0	UART0_RTS		SPIO_MOSI	I2S1_SD_TX	PCM1_OUT		PWM2	ETE2			HI	
GPIOC_3				TX_CK	UART0_OUT		SPIO_MISO	I2S1_MCK	PCM1_IN		PWM3	ETE3		GPIO_INT	HI	0
GPIOC_4				TXD3		I2C1_SDA	SPIO_CS1	I2S1_SD_RX						GPIO_INT	HI	
GPIOC_5				TXEN		I2C1_SCL	SPIO_CS2							GPIO_INT	HI	0
GPIOD_4				MDC	UART2_IN	I2C0_SDA	SPI1_CS		PCM1_SYNC		PWM0	ETE0		GPIO_INT	PH	0
GPIOD_5				MDIO	UART2_CTS	I2C0_SCL	SPI1_CLK		PCM1_CLK		PWM1	ETE1	D_SBY2	GPIO_INT	PH	0
GPIOD_6					UART2_RTS	I2C1_SCL	SPI1_MOSI	I2S0_SD_RX	PCM1_OUT		PWM2	ETE2		GPIO_INT	PH	0
GPIOD_7					UART2_OUT	I2C1_SDA	SPI1_MISO		PCM1_IN		PWM3	ETE3		GPIO_INT	PH	0
GPIOE_0	TRST				UART0_OUT	I2C2_SCL	SPIO_CS0	I2S0_WS	PCM0_SYNC		PWM0				PH	0
GPIOE_1	TDI				UART0_RTS	I2C2_SDA	SPIO_CLK	I2S0_CLK	PCM0_CLK		PWM1			GPIO_INT	PH	0
GPIOE_2	TDO				UART0_CTS	I2C3_SCL	SPIO_MOSI	I2S0_SD_TX	PCM0_OUT		PWM2			GPIO_INT	PH	0
GPIOE_3	TMS				UART0_IN	I2C3_SDA	SPIO_MISO	I2S0_MCK	PCM0_IN		PWM3		D_SBY3	GPIO_INT	PH	0
GPIOE_4	CLK					I2C3_SCL	SPIO_CS1								PH	0
GPIOE_5						I2C3_SDA	SPIO_CS2							GPIO_INT	PH	0

NOTE1: PH = Pull-High, HI = High-impedance

NOTE2: GPIOA\_1 needs external Circuit to do the pull high control; others' pull control can be done by register setting (including GPIOA\_1's PD).

## 5.2 Peripheral Descriptions

		<b>Baud rate</b>
UART	UART_LOG	38400 Hz
	UART0	4 MHz
	UART2	4 MHz
		<b>Clock rate</b>
SPI	SPI0_Master	20.8 MHz
	SPI0_Slave_TRx	4.1 MHz
	SPI1_Master	41.6 MHz
	SPI1_Slave_TRx	--
		<b>Clock rate</b>
I2C	Standard mode	0~100 kb/s
	Fast mode	<400 kb/s
	High-speed mode	<3.4Mb/s

## 6 Hardware configuration

### 6.1 CMSIS-DAP

RTL-AMEBA\_DEV01 supports CMSIS-DAP debugger. It requires installing “serial to USB driver” at first. Serial to USB driver can be found in tools\serial\_to\_usb\mbedWinSerial\_16466.

Connect board to the PC with micro-USB cable.

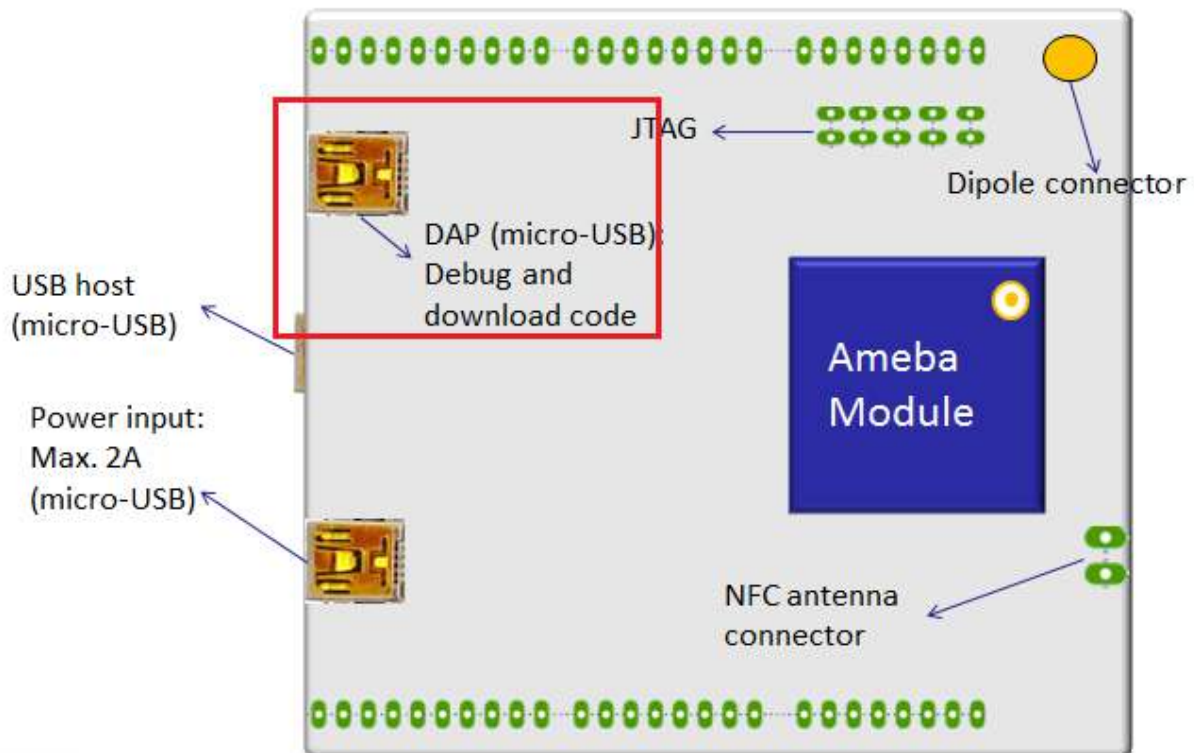



## 6.2 J-Link/JTAG

Weld JTAG and log UART connectors to HDK board and connect with pitch 2.54mm 2x5pins connector. It is recommended to weld the connector on the bottom side. Users can connect extension boards from top side.

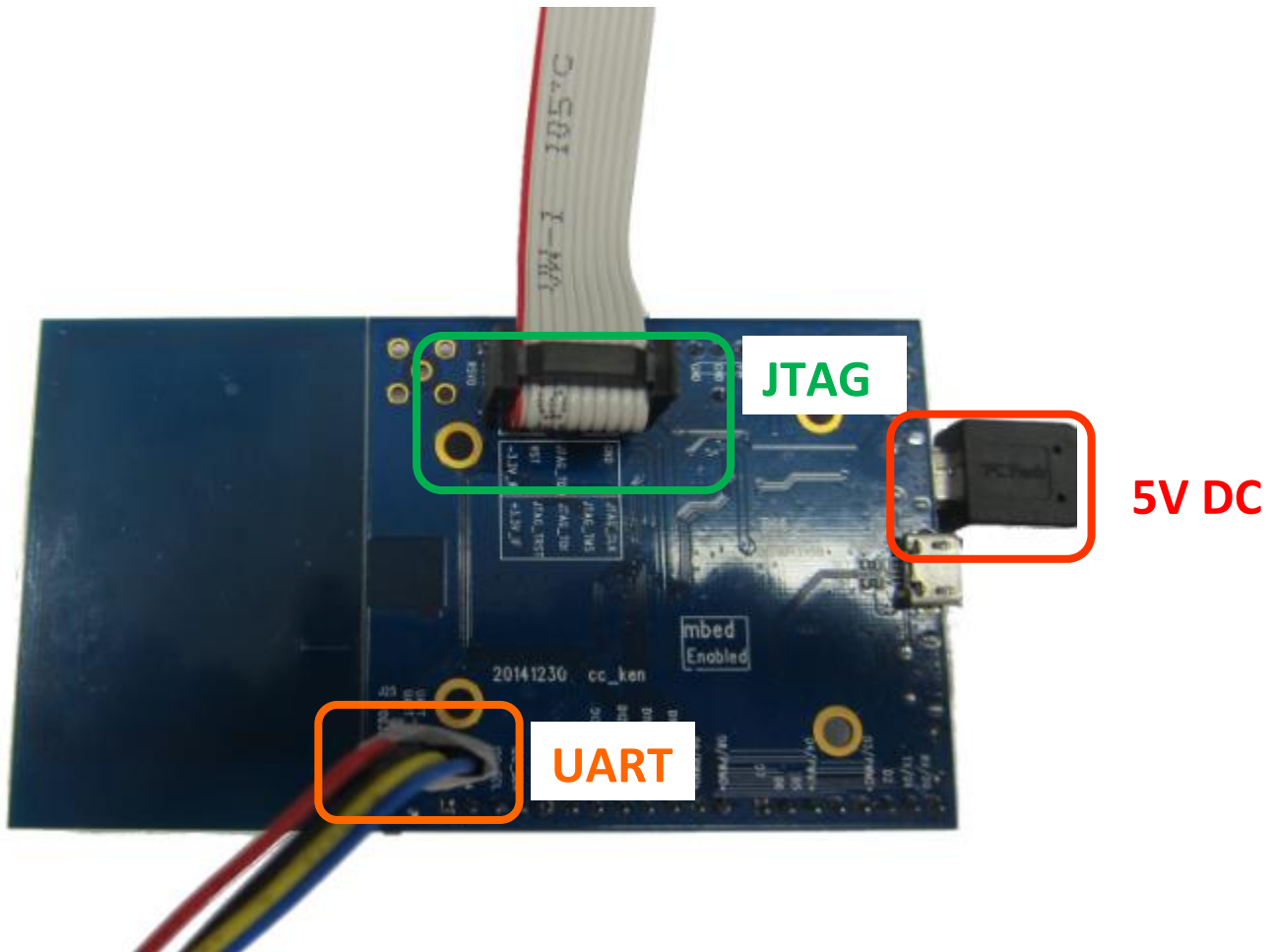

Dupont Line or 2.54mm 2x5 pins connector.



### Power On(Disable DAP mode)

Holding TGT\_NRESET button (J24, red-circled) then press Pdn button (J13, blue-circled). Release the button after power on.

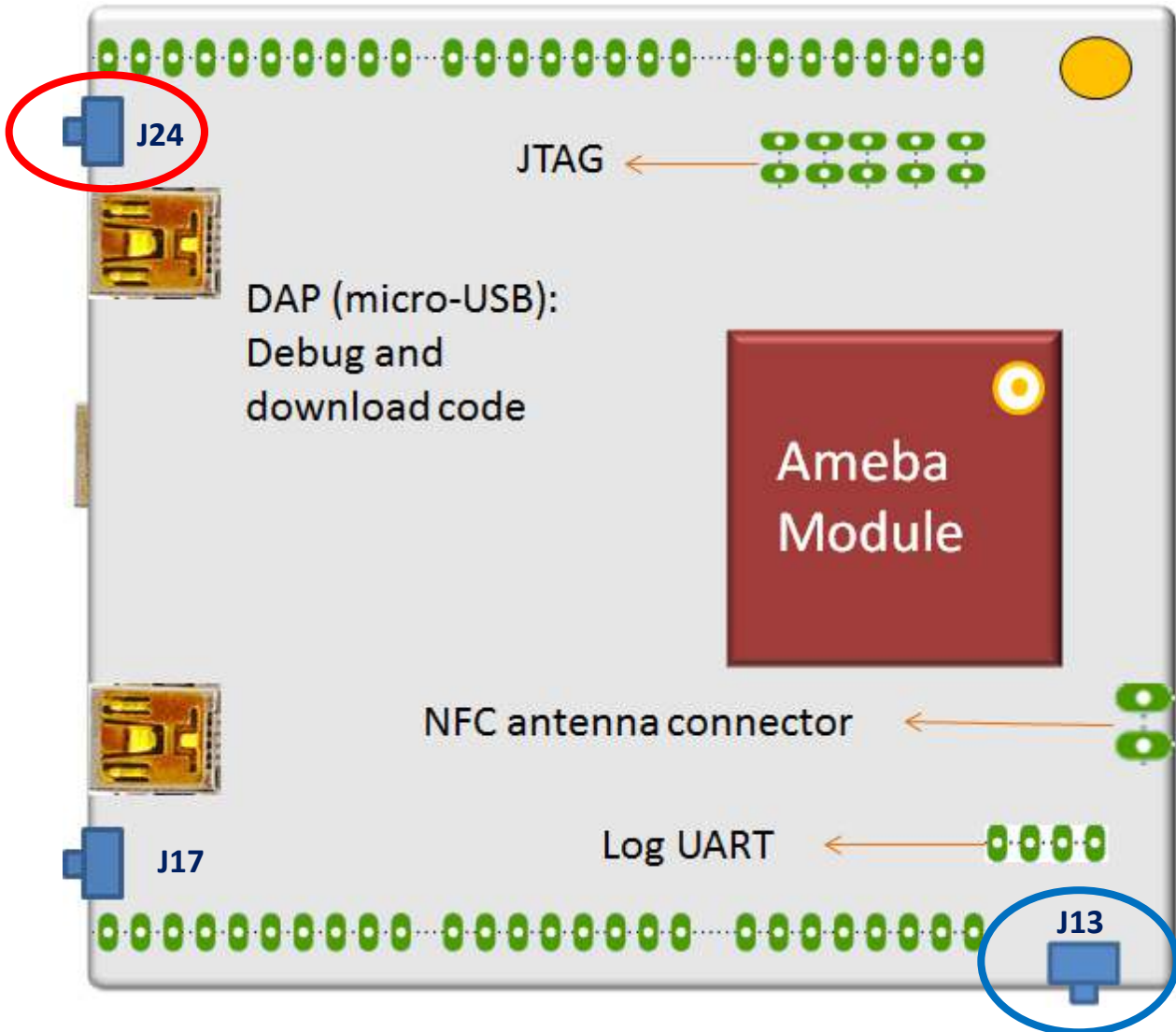

## 6.3 DAP mode

In DAP mode, the DAP firmware can be updated.

Holding TGT\_NRESET button (J24, red-circled) then press nRESET button (J17, blur-circled). Then the DAP mode window will show up.

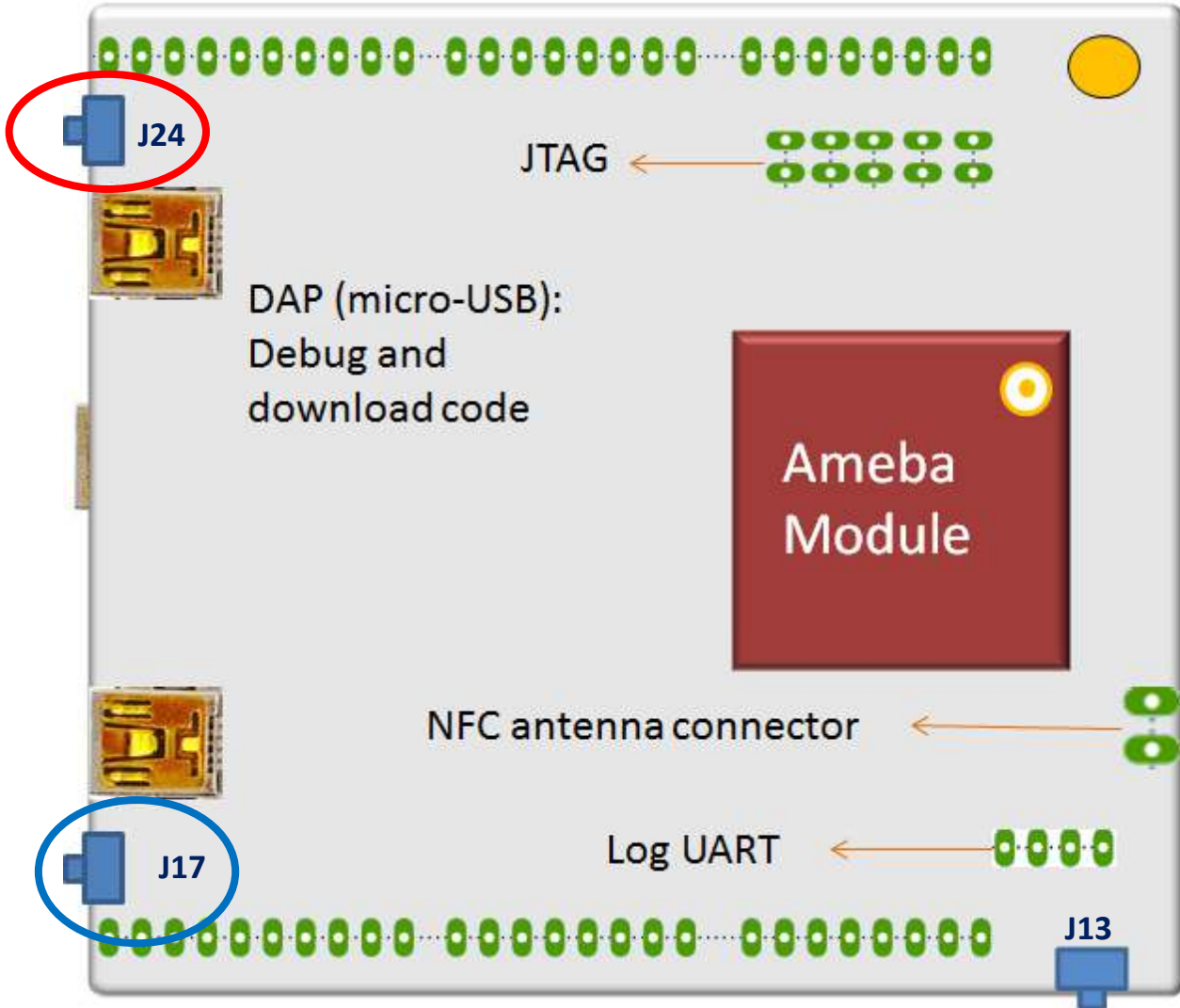

DAP window will show up when entering DAP mode.



# 7 Reference electrical schematics

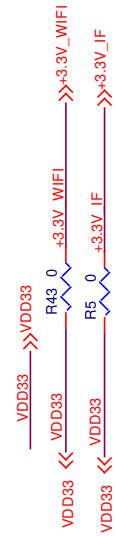
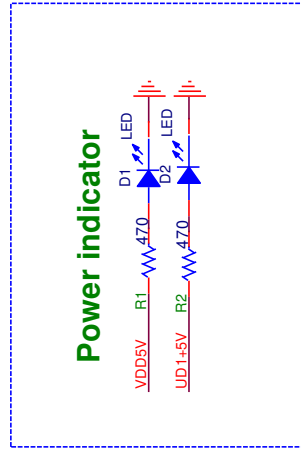
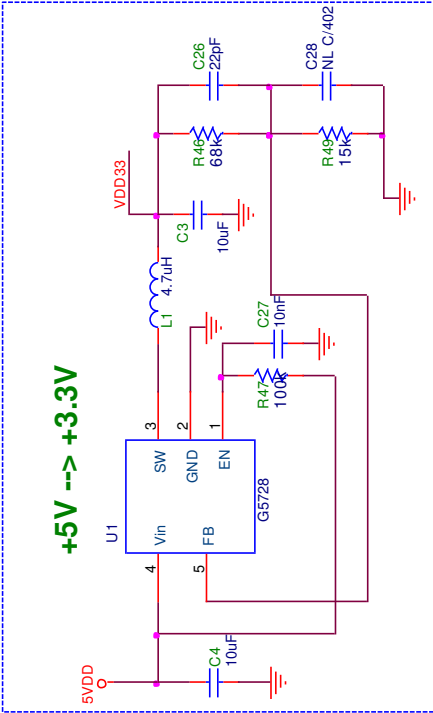

Title		
Size	Document Number	Rev
Custom	<b>DC Power</b>	1.0
Date:	Sheet 1	of 2

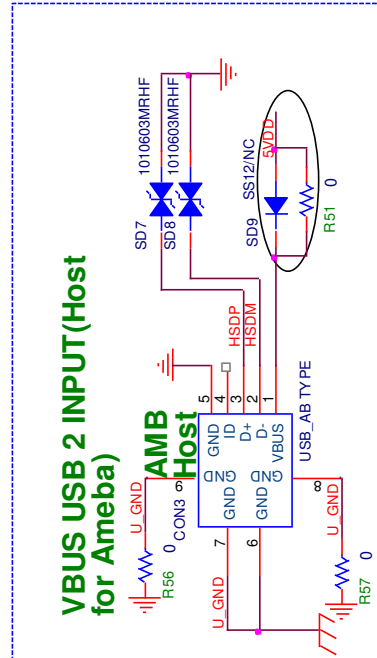
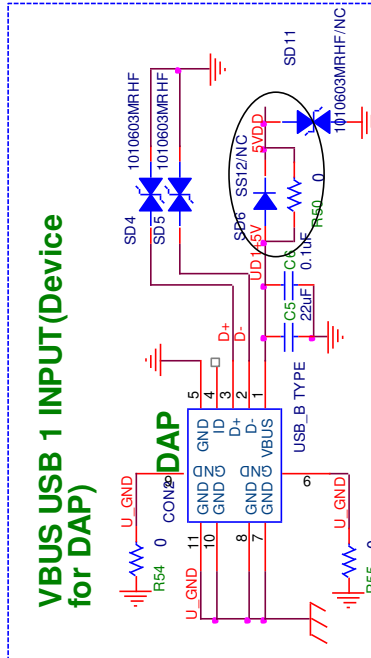
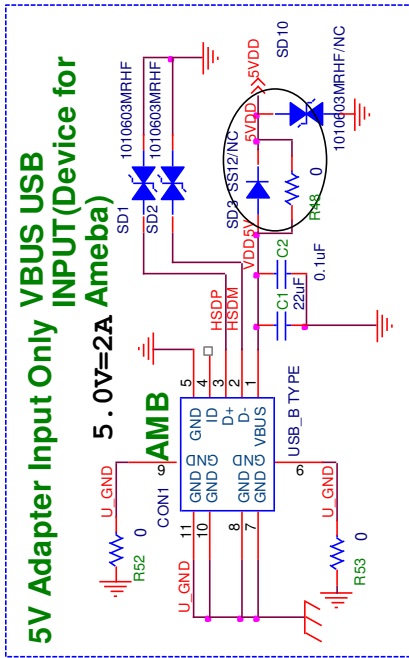

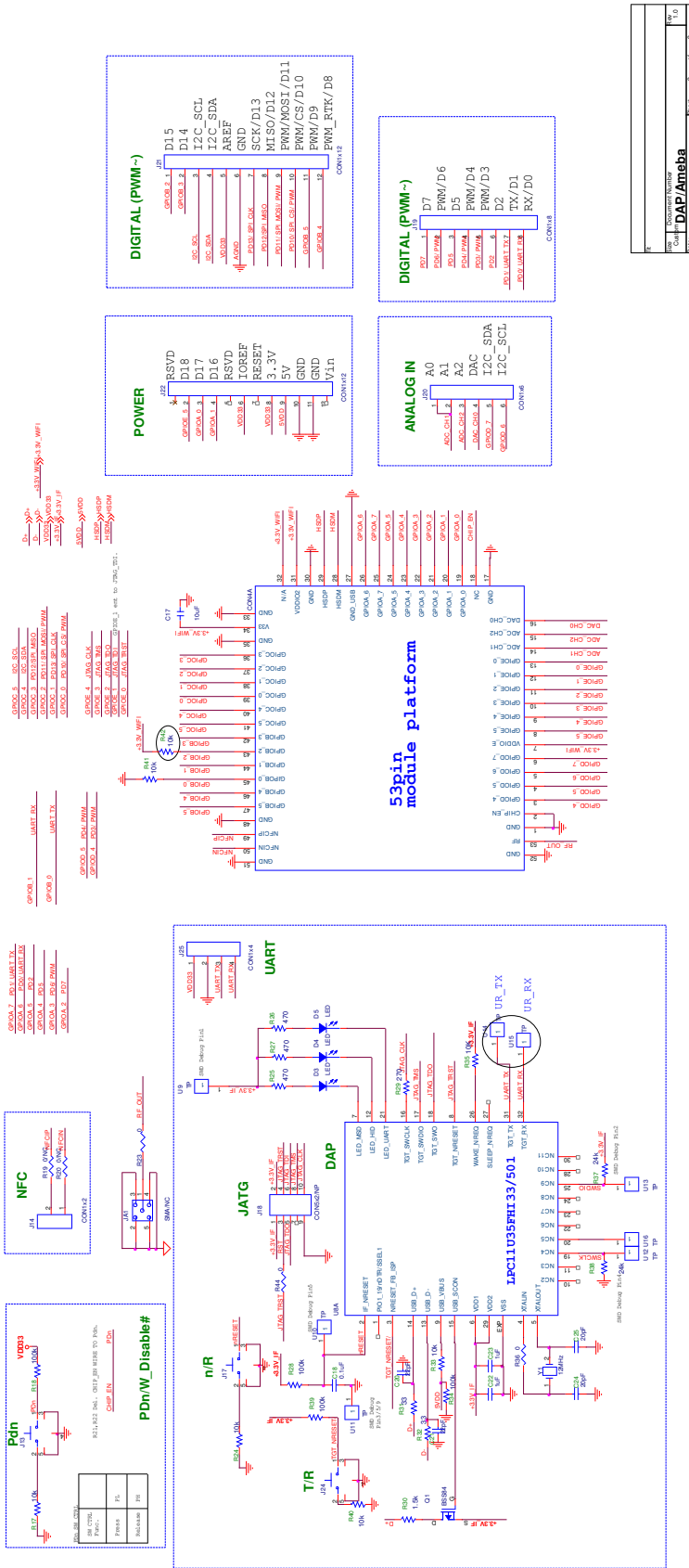

## 8 Sensor board

- Extension board: RTL-AMEBA\_EXT B2\_2V0

