

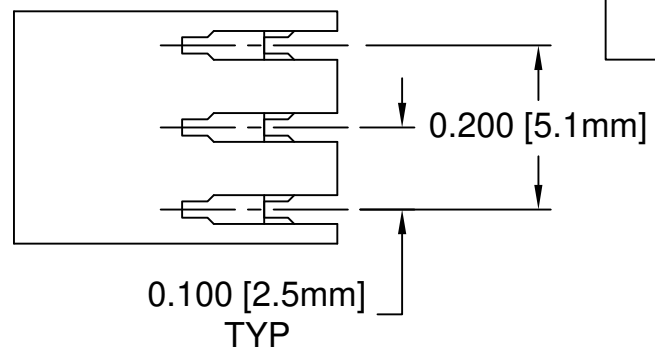

REV.	DESCRIPTION	DATE	APPROVED
D	Engineering Release	05/31/13	T. Y.
E	Removed Material Code	05/28/16	J. C.

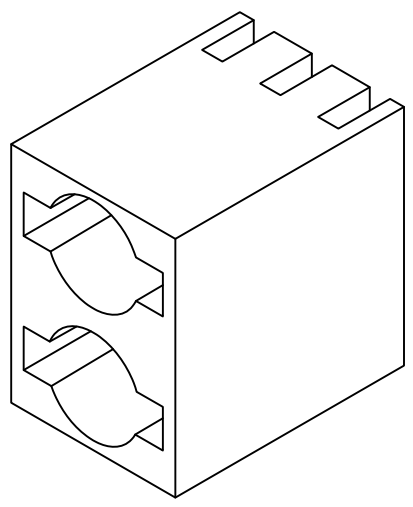
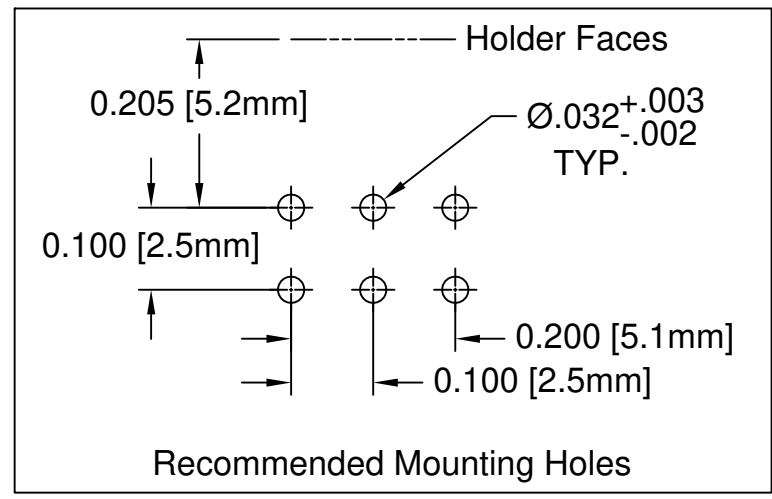
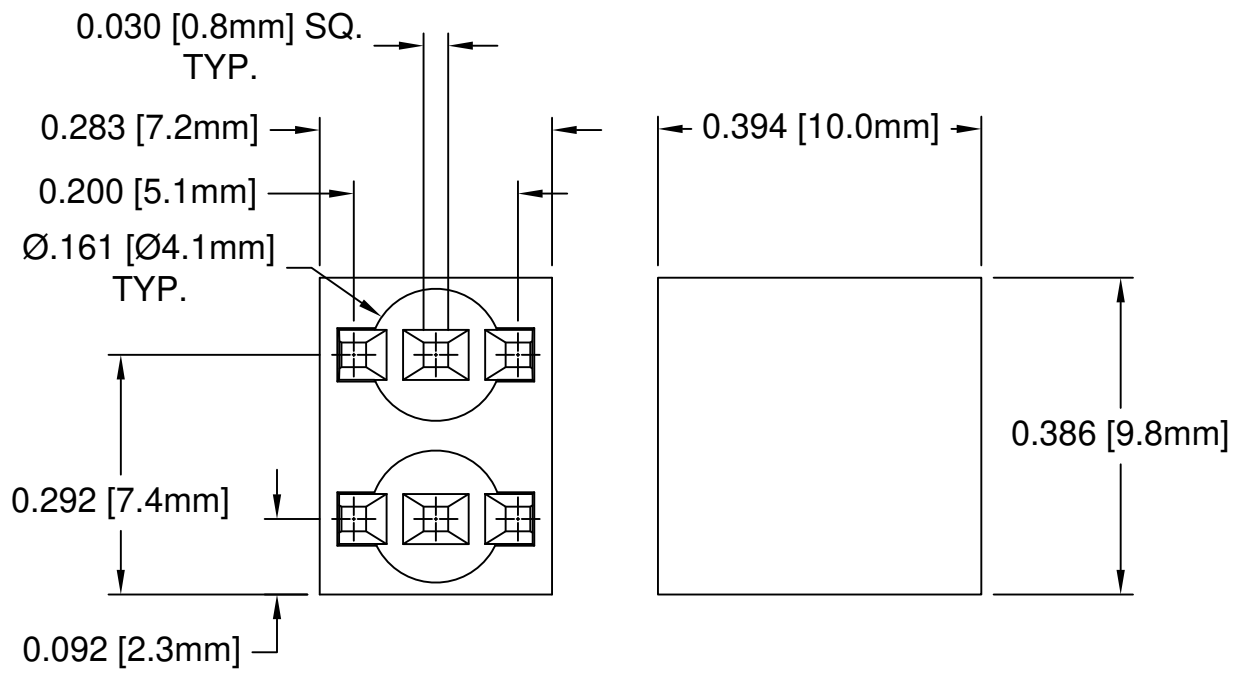
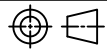

- 2. MATERIAL: NYLON 6/6, 94V-0, BLACK.
- 1. GENERAL SPECIFICATIONS: BIVAR MOLDED COMPONENT SPECIFICATION BV00-E101.

STANDARD TOLERANCE (UNLESS OTHERWISE SPECIFIED)		 4 THOMAS, IRVINE, CA. 92618 TEL: (949) 951-8808 FAX: (949) 951-3974	
DECIMALS	ANGULAR		
.X ± .1	X° ± 1°		TITLE: BI-LEVEL T1 (3mm) TRI-LEAD LED HOLDER
.XX ± .01			DESIGNED: S. Irving
.XXX ± .005			DATE: 02/16/99
		DESIGNED: M. Chen	REVISION: E
		CHECKED: M. Chen	DATE: 03/06/03
		PART NO: H-280C	
		CAGE CODE : 32559	SHEET # 1 OF 1
CAD GENERATED DOCUMENT. DO NOT MEASURE DRAWING.			