

THYRISTOR MODULE

PK(PD,PE)110FG

UL;E76102(M)

Power Thyristor/Diode Module PK110FG series are designed for various rectifier circuits and power controls. For your circuit application, following internal connections and wide voltage ratings up to 1600V are available. and electrically isolated mounting base make your mechanical design easy.

- $I_{T(AV)}$ 110A, $I_{T(RMS)}$ 172A, I_{TSM} 3000A
- di/dt 100A/ μ s
- dv/dt 1000V/ μ s

(Applications)

- Various rectifiers
- AC/DC motor drives
- Heater controls
- Light dimmers
- Static switches

Internal Configurations

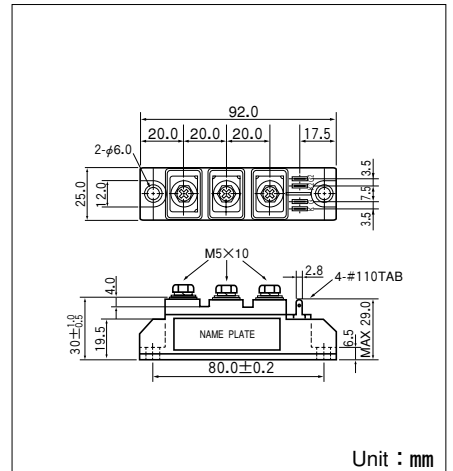
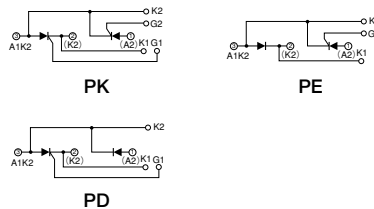

Unit : mm

Maximum Ratings

($T_j=25^\circ\text{C}$ unless otherwise specified)

Symbol	Item	Ratings				Ratings
		PK110FG40 PD110FG40 PE110FG40	PK110FG80 PD110FG80 PE110FG80	PK110FG120 PD110FG120 PE110FG120	PK110FG160 PD110FG160 PE110FG160	
V_{RRM}	* Repetitive Peak Reverse Voltage	400	800	1200	1600	V
V_{RSM}	* Non-Repetitive Peak Reverse Voltage	480	960	1300	1700	V
V_{DRM}	* Repetitive Peak off-state Voltage	400	800	1200	1600	V

Symbol	Item	Conditions	Ratings	Unit	
$I_{T(AV)}$	* Average On-state Current	Single phase, half wave, 180° conduction, $T_c=81^\circ\text{C}$	110	A	
$I_{T(RMS)}$	* R.M.S. On-state Current	Single phase, half wave, 180° conduction, $T_c=81^\circ\text{C}$	172	A	
I_{TSM}	* Surge On-state Current	$\frac{1}{2}$ Cycle, 50/60Hz, Peak Value, non-repetitive	2740/3000	A	
I_t	* I_t	Value for one cycle surge current	37500	A ² S	
P_{GM}	Peak Gate Power Dissipation		10	W	
$P_{G(AV)}$	Average Gate Power Dissipation		1	W	
I_{FGM}	Peak Gate Current		3	A	
V_{FGM}	Peak Gate Voltage (Forward)		10	V	
V_{RGM}	Peak Gate Voltage (Reverse)		5	V	
di/dt	Critical Rate of Rise of On-state Current	$I_G=100\text{mA}$, $V_D=\frac{1}{2}V_{DRM}$, $di/dt=0.1\text{A}/\mu\text{s}$	100	A/ μs	
V_{ISO}	* Isolation Breakdown Voltage (R.M.S.)	A.C. 1minute	2500	V	
T_j	* Operating Junction Temperature		-40 to +125	$^\circ\text{C}$	
T_{stg}	* Storage Temperature		-40 to +125	$^\circ\text{C}$	
	Mounting Torque	Mounting (M5)	Recommended Value 1.5-2.5 (15-25)	2.7 (28)	N·m (kgf·cm)
		Terminal (M5)	Recommended Value 1.5-2.5 (15-25)	2.7 (28)	
	Mass	Typical Value	170	g	

Electrical Characteristics

Symbol	Item	Conditions	Ratings	Unit
I_{DRM}	Repetitive Peak off-state Current,max	$T_j=125^\circ\text{C}$, $V_D=V_{DRM}$	30	mA
I_{RRM}	* Repetitive Peak Reverse Current,max	$T_j=125^\circ\text{C}$, $V_D=V_{DRM}$	30	mA
V_{TM}	* On-state Voltage,max	$I_T=330\text{A}$	1.6	V
I_{GT}	Gate Trigger Current,max	$V_D=6\text{V}$, $I_T=1\text{A}$	50	mA
V_{GT}	Gate Trigger Voltage,max	$V_D=6\text{V}$, $I_T=1\text{A}$	3	V
V_{GD}	Gate Non-Trigger Voltage,min	$T_j=125^\circ\text{C}$, $V_D=\frac{1}{2}V_{DRM}$	0.25	V
dv/dt	Critical Rate of Rise of off-state Voltage,min	$T_j=125^\circ\text{C}$, $V_D=\frac{2}{3}V_{DRM}$	1000	V/ μs
$R_{th(j-c)}$	* Thermal Impedance,max	Junction to case	0.25	$^\circ\text{C}/\text{W}$

* mark : Thyristor and Diode part. No mark : Thyristor part

