

# FP-LWAB

## Large Flat Panel Articulating Wall Mount

### Product Features:

- Holds most 42" – 80" flat panels
- Maximum flat panel hole pattern – 800mm x 500mm
- Depth – 2.9" to 18.2"
- Adjustable tilt – 0° to 15° / Rotates – 45°
- List adjustment –  $\pm 3^\circ$
- Mounting rails accept padlocks
- Clip based cable management system
- Load capacity – 150 lbs
- Black powder coat finish
- UL listed

### Product Specifications:

*(for Architects & Engineers)*

The articulating wall mount for the 42" to 80" flat panel display shall be the Video Mount Products (VMP) FP-LWAB.

The mount shall be designed to attach to 2 studs approximately 16" apart or other suitable support surface.

The mount shall be constructed primarily of formed steel and aluminum and shall incorporate arc welds. The mount shall be a universal style mount capable of adjusting to the dimensions of a variety of popular 42" to 80" flat panel displays and not necessarily be model specific. The adjustable mounting rails shall be capable of accommodating a maximum hole pattern of 800 mm wide and 500 mm tall.

The mount shall have an adjustable distance from wall that ranges between 2.9" to 18.2". The mount shall be capable of tilting from 0° to +15°. The mount shall incorporate post install level correction capability of  $\pm 3^\circ$ . The mounting rails shall be capable of accepting a pad lock to further secure the flat panel against theft. The mount shall have a UL listed load capacity of 150 lbs. The mount shall come in a black powder coat finish.

### Video Mount Products

345 Log Canoe Circle  
Stevensville, MD 21666  
Toll Free: 877.281.2169  
Telephone: 410.643.6390  
Facsimile: 410.643.6615  
[www.videomount.com](http://www.videomount.com)

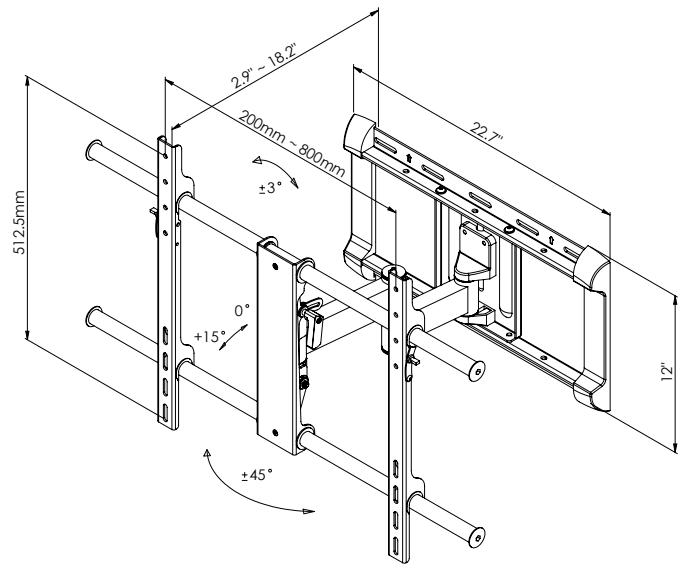

**VMP**  
VIDEO MOUNT PRODUCTS