

FEATURES

- Scannable version E112 driver
- Extended 100E VEE range of -4.2V to -5.5V
- 1025ps max. CLK to Output
- Dual differential outputs
- Master Reset
- Internal 75KΩ input pull-down resistors
- Fully compatible with industry standard 10KH, 100K ECL levels
- Fully compatible with Motorola MC10E/100E212
- Available in 28-pin PLCC package

DESCRIPTION

The SY10/100E212 are scannable registered ECL drivers typically used as fan-out memory address drivers for ECL cache driving. In a VLSI array-based CPU design, use of the E212 allows the user to conserve array output cell functionality and also output pins.

The input shift register is designed with control logic which greatly facilitates its use in boundary scan applications.

BLOCK DIAGRAM

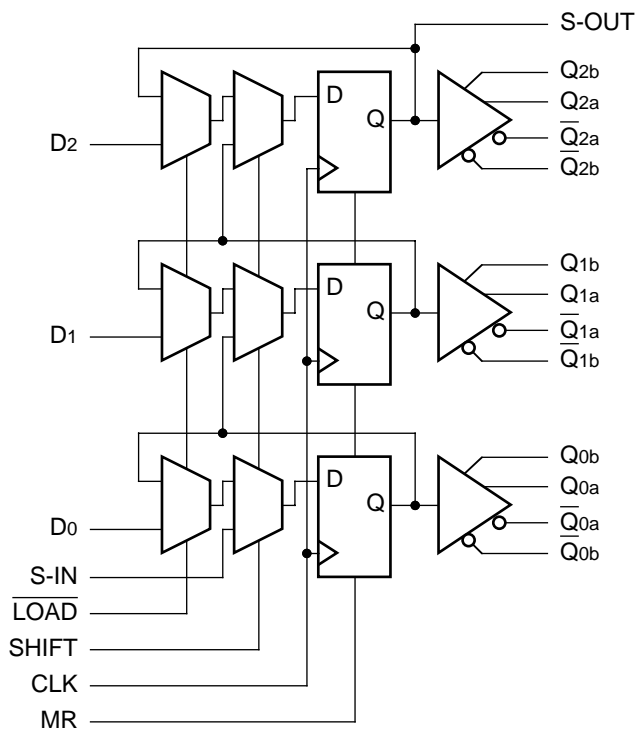

PIN NAMES

Pin	Function
D0 – D2	Data Inputs
S-IN	Scan Input
LOAD	LOAD/HOLD Control
SHIFT	Scan Control
CLK	Clock
MR	Master Reset
S-OUT	Scan Output
Q[0:2]a, Q[0:2]b	True Outputs
\overline{Q} [0:2]a, \overline{Q} [0:2]b	Inverting Outputs
Vcco	Vcc to Output

PACKAGE/ORDERING INFORMATION

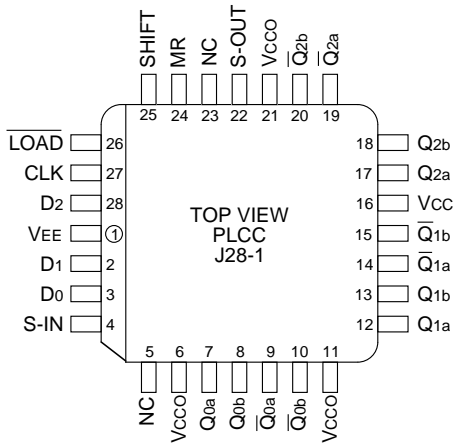

28-Pin PLCC (J28-1)

Ordering Information⁽¹⁾

Part Number	Package Type	Operating Range	Package Marking	Lead Finish
SY10E212JC	J28-1	Commercial	SY10E212JC	Sn-Pb
SY10E212JCTR ⁽²⁾	J28-1	Commercial	SY10E212JC	Sn-Pb
SY100E212JC	J28-1	Commercial	SY100E212JC	Sn-Pb
SY100E212JCTR ⁽²⁾	J28-1	Commercial	SY100E212JC	Sn-Pb
SY10E212JZ ⁽³⁾	J28-1	Commercial	SY10E212JZ with Pb-Free bar-line indicator	Matte-Sn
SY10E212JZTR ^(2, 3)	J28-1	Commercial	SY10E212JZ with Pb-Free bar-line indicator	Matte-Sn
SY100E212JZ ⁽³⁾	J28-1	Commercial	SY100E212JZ with Pb-Free bar-line indicator	Matte-Sn
SY100E212JZTR ^(2, 3)	J28-1	Commercial	SY100E212JZ with Pb-Free bar-line indicator	Matte-Sn

Notes:

1. Contact factory for die availability. Dice are guaranteed at $T_A = 25^\circ\text{C}$, DC Electricals only.
2. Tape and Reel.
3. Pb-Free package is recommended for new designs.

TRUTH TABLE

$\overline{\text{LOAD}}$	SHIFT	MR	Mode
L	L	L	Load
H	L	L	Hold
X	H	L	Shift
X	X	H	Reset

DC ELECTRICAL CHARACTERISTICS

VEE = VEE (Min.) to VEE (Max.); VCC = VCC = GND

Symbol	Parameter	TA = 0°C			TA = +25°C			TA = +85°C			Unit	Condition
		Min.	Typ.	Max.	Min.	Typ.	Max.	Min.	Typ.	Max.		
I _{IH}	Input HIGH Current	—	—	150	—	—	150	—	—	150	μA	—
I _{EE}	Power Supply Current	10E	80	96	—	80	96	—	80	96	mA	—
		100E	80	96	—	80	96	—	92	110		

AC ELECTRICAL CHARACTERISTICS

VEE = VEE (Min.) to VEE (Max.); VCC = VCC = GND

Symbol	Parameter	TA = 0°C			TA = +25°C			TA = +85°C			Unit	Condition
		Min.	Typ.	Max.	Min.	Typ.	Max.	Min.	Typ.	Max.		
t _{PD}	Propagation Delay to Output	575	800	1025	575	800	1025	575	800	1025	ps	—
	CLK	575	800	1025	575	800	1025	575	800	1025		
	MR	575	800	1025	575	800	1025	575	800	1025		
t _s	Set-up Time	175	25	—	175	25	—	175	25	—	ps	—
	D	150	-50	—	150	-50	—	150	-50	—		
	SHIFT	225	50	—	225	50	—	225	50	—		
t _H	Hold Time	150	-50	—	150	-50	—	150	-50	—	ps	—
	D	250	25	—	250	25	—	250	25	—		
	SHIFT	300	100	—	300	100	—	300	100	—		
t _{RR}	Reset Recovery	225	0	—	225	0	—	225	0	—	ps	—
	LOAD	300	100	—	300	100	—	300	100	—		
	S-IN	300	100	—	300	100	—	300	100	—		
t _{skew}	Within-Device Skew	—	100	—	—	100	—	—	100	—	ps	1
t _{skew}	Within-Gate Skew	—	50	—	—	50	—	—	50	—	ps	2
t _r t _f	Rise/Fall Times 20% to 80%	275	425	650	275	425	650	275	425	650	ps	—

Notes:

1. Within-device skew is defined as identical transitions on similar paths through a device.
2. Within-gate skew is defined as the difference in delays between various outputs of a gate when driven from the same input.

28-PIN PLCC (J28-1)

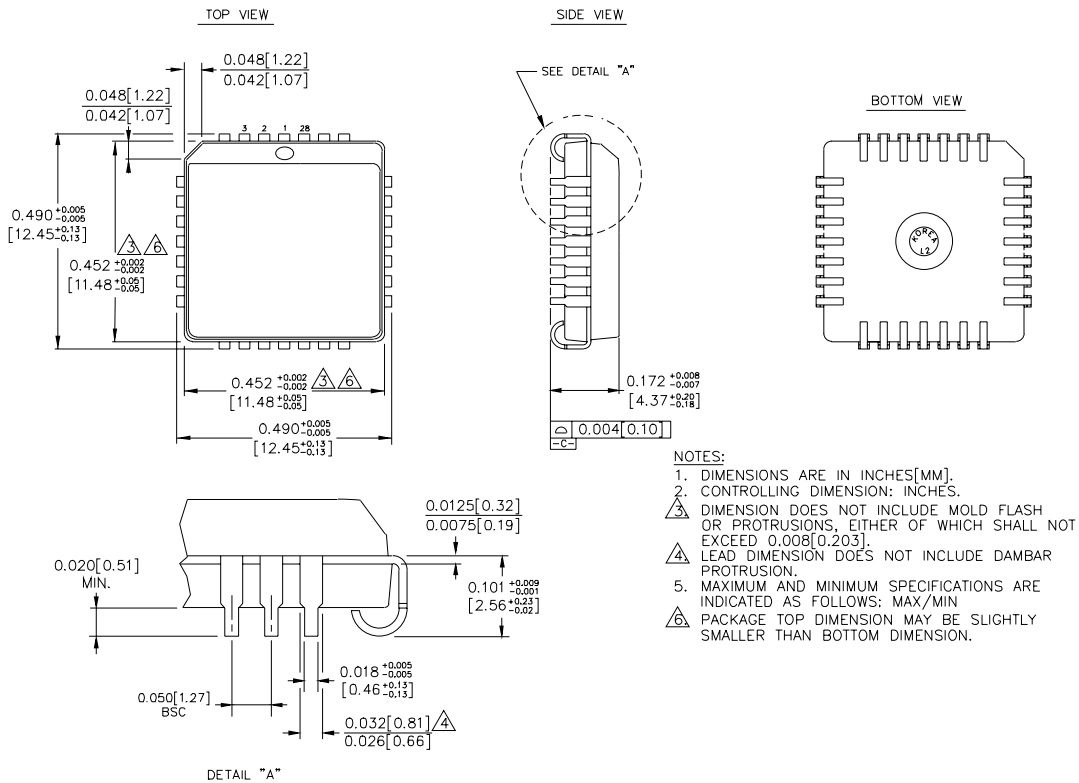

- NOTES:
1. DIMENSIONS ARE IN INCHES[MM].
 2. CONTROLLING DIMENSION: INCHES.
 3. DIMENSION DOES NOT INCLUDE MOLD FLASH OR PROTRUSIONS, EITHER OF WHICH SHALL NOT EXCEED 0.008[0.203].
 4. LEAD DIMENSION DOES NOT INCLUDE DAMBAR PROTRUSION.
 5. MAXIMUM AND MINIMUM SPECIFICATIONS ARE INDICATED AS FOLLOWS: MAX/MIN
 6. PACKAGE TOP DIMENSION MAY BE SLIGHTLY SMALLER THAN BOTTOM DIMENSION.

Rev. 03

MICREL, INC. 2180 FORTUNE DRIVE SAN JOSE, CA 95131 USA

TEL + 1 (408) 944-0800 FAX + 1 (408) 474-1000 WEB <http://www.micrel.com>

The information furnished by Micrel in this data sheet is believed to be accurate and reliable. However, no responsibility is assumed by Micrel for its use. Micrel reserves the right to change circuitry and specifications at any time without notification to the customer.

Micrel Products are not designed or authorized for use as components in life support appliances, devices or systems where malfunction of a product can reasonably be expected to result in personal injury. Life support devices or systems are devices or systems that (a) are intended for surgical implant into the body or (b) support or sustain life, and whose failure to perform can be reasonably expected to result in a significant injury to the user. A Purchaser's use or sale of Micrel Products for use in life support appliances, devices or systems is at Purchaser's own risk and Purchaser agrees to fully indemnify Micrel for any damages resulting from such use or sale.

© 2006 Micrel, Incorporated.