

ORDER NO.	WOODHEAD NO.	COLOR
130142-0035	2849	YELLOW

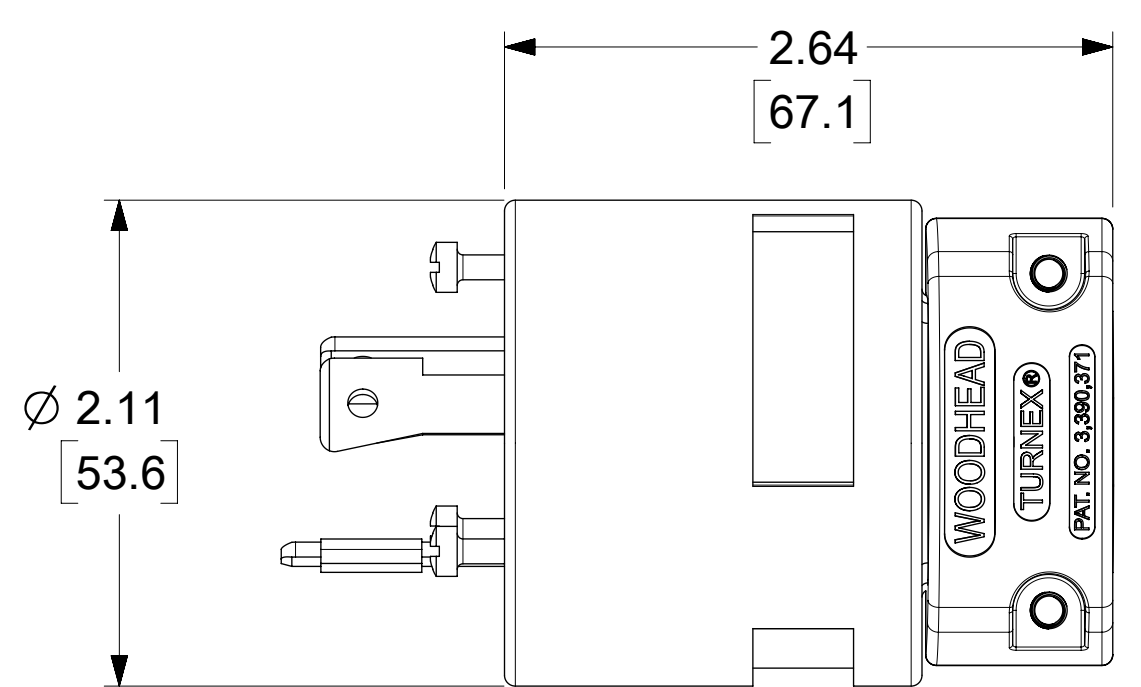

**WIRING TERMINATION**

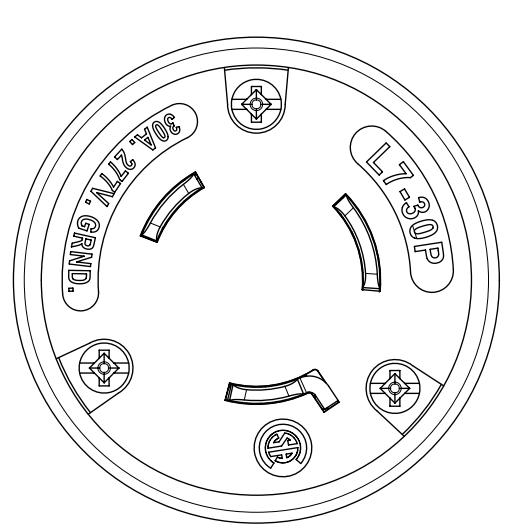
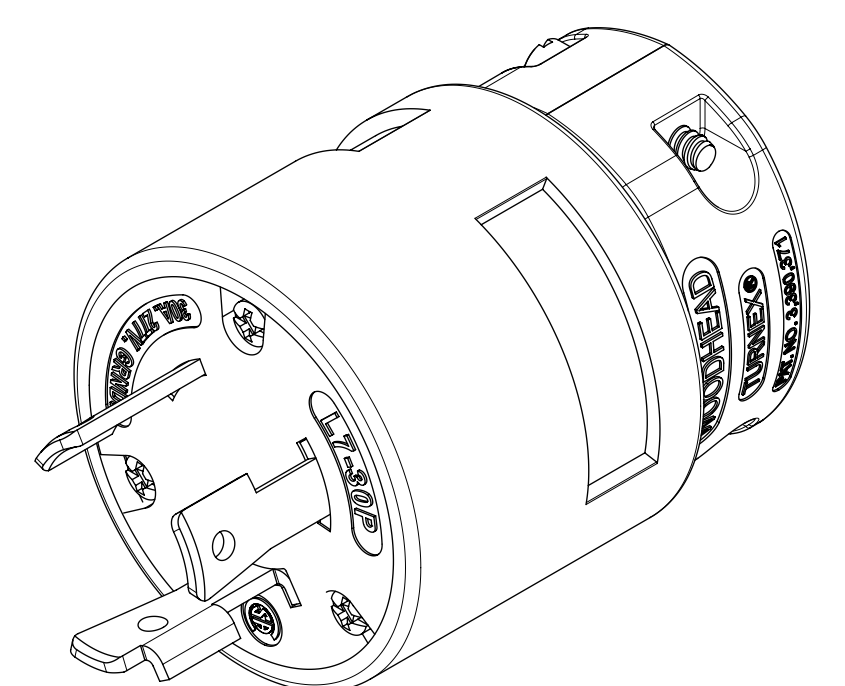
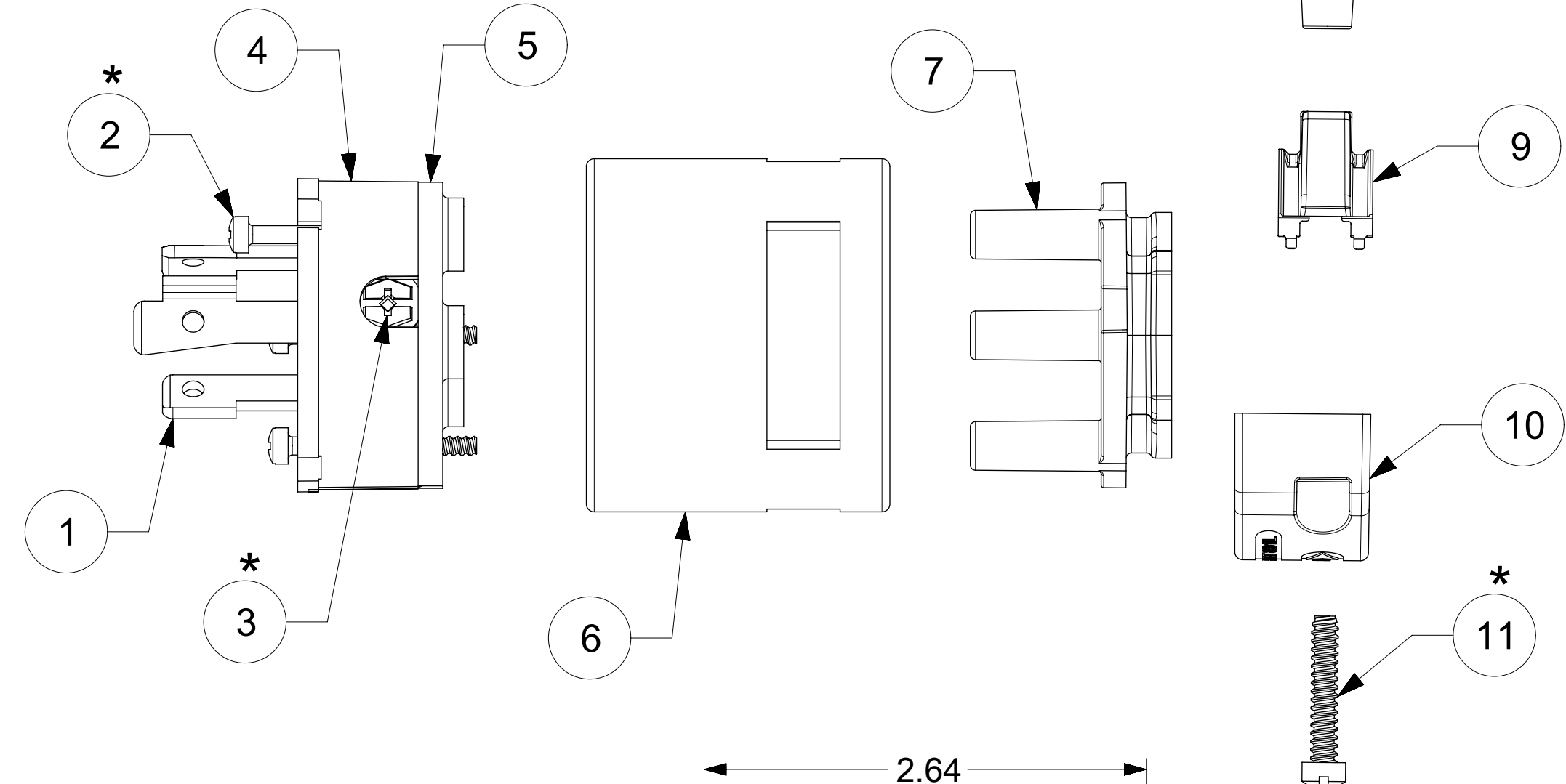
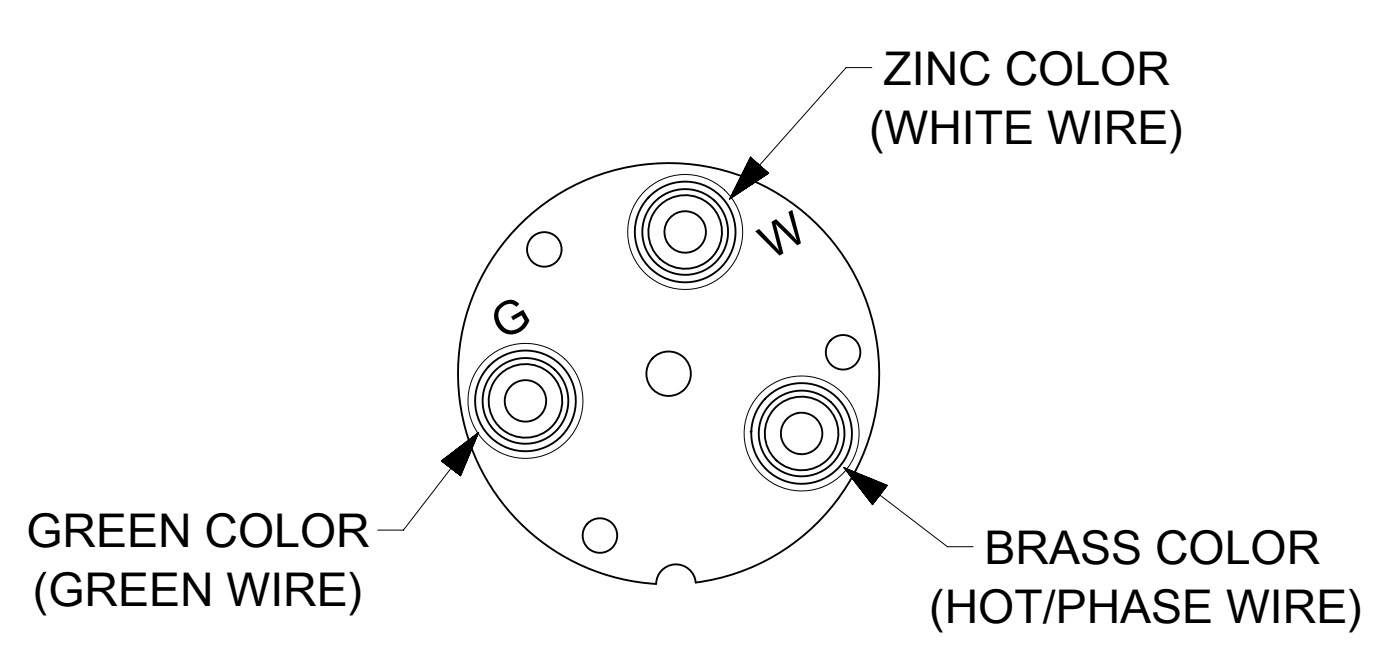

\* FOR SCREW TORQUE, SEE ASSEMBLY INSTRUCTIONS

ITEM NO.	DESCRIPTION	MATERIAL	QTY.
1	BLADES	BRASS, NICKEL PLATED	3
2	RETAINING SCREWS	STAINLESS STEEL	3
3	TERMINAL SCREWS/CLAMP ASSEMBLY	BRASS, ZINC PLATED	3
4	INSERT; YELLOW	NYLON	1
5	TERMINAL COVER	POLYCARBONATE	1
6	MALE RUBBER HUSK	NYLON	1
7	CLAMP SUPPORT, YELLOW	NYLON	1
8	CLAMP CHORD MALE, YELLOW	NYLON	1
9	CLAMP CHORD INSERT, WHITE	NYLON	1
10	CLAMP CORD FEMALE, YELLOW	NYLON	1
11	RETAINING SCREWS	STAINLESS STEEL	2

SYMBOLS		THIS DRAWING CONTAINS INFORMATION THAT IS PROPRIETARY TO MOLEX ELECTRONIC TECHNOLOGIES, LLC AND SHOULD NOT BE USED WITHOUT WRITTEN PERMISSION	
▽ = 0	INCH	SCALE	CURRENT REV DESC: NEW RELEASE
▽ = 0	NTS		
▽ = 0	GENERAL TOLERANCES (UNLESS SPECIFIED)		
▽ = 0		MM	INCH
▽ = 0	4 PLACES	±	±
▽ = 0	3 PLACES	±	±
▽ = 0	2 PLACES	±	±
▽ = 0	1 PLACE	±	±
▽ = 0	0 PLACES	±	±
▽ = 0	ANGULAR TOL	± °	
▽ = 0	DRAFT WHERE APPLICABLE MUST REMAIN WITHIN DIMENSIONS		
▽ = 0	THIRD ANGLE PROJECTION	DRAWING	SERIES
		C-SIZE	130142
		EC NO: 628447	
		DRWN: ABENJAMINLW	2019/04/01
		CHK'D: DNGUYEN62	2020/01/14
		APPR: HKNEELAND	2020/04/11
		INITIAL REVISION:	
		DRWN: ABENJAMINLW	2019/04/01
		APPR: HKNEELAND	2020/04/11
DOCUMENT NUMBER		DOC TYPE	DOC PART
1301420035		PSD	000
MATERIAL NUMBER		CUSTOMER	SHEET NUMBER
SEE TABLE		GENERAL MARKET	1 OF 1