

- 1. MATERIALS:**
- CONTACTS:** PHOSPHOR BRONZE, PLATING: SELECTIVE GOLD PLATING ON MATING SURFACES. SEE PART NO. FOR THICKNESS. 50 MICRO" MIN. NICKEL OVERALL. 100 MICRO" MIN. MATTE TIN OR GOLD FLASH ON TAILS.
- HOUSING:** ENGINEERING PLASTIC COLOR - BLACK. FLAMMABILITY RATING UL 94V-0
- SHIELD:** COPPER ALLOY PLATING: NICKEL WITH TIN DIPPED PCB TAILS.

AMPHENOL PART NO.: RJSBE-X380-C1

- GOLD PLATING OPTION:
- D = 6u" GOLD PLATING
 - G = 15u" GOLD PLATING
 - J = 30u" GOLD PLATING
 - 5 = 50u" GOLD PLATING

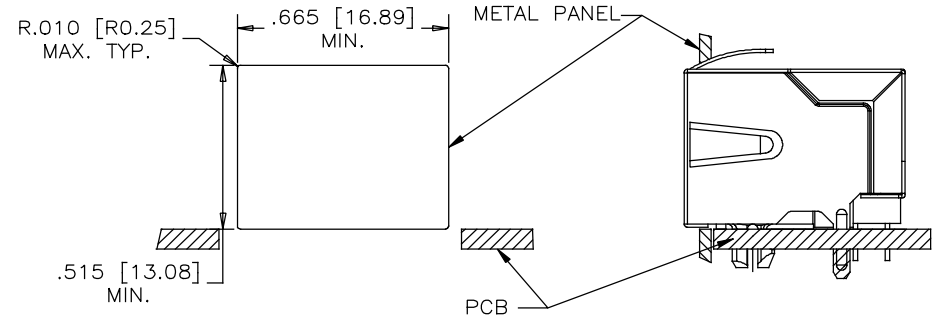

THIS DOCUMENT CONTAINS PROPRIETARY INFORMATION AND SUCH INFORMATION MAY NOT BE DISCLOSED TO OTHERS FOR ANY PURPOSE OR USED FOR MANUFACTURING PURPOSES WITHOUT WRITTEN PERMISSION FROM AMPHENOL CANADA CORP.

UNLESS SPECIFIED OTHERWISE	DRAWN	RONNIE.C	SEP 25/17
PRIMARY UNITS INCHES	CHECKED	AMY.Z	SEP 25/17
SECONDARY MILLIMETERS	M.E. APP'D		
REFERENCE IN PARENTHESES	Q.A. APP'D		
	DWG APP'D		
	ENG. REL. NO.		
1 DECIMAL PLACE	REF.	EAR# RJ17172	
2 DECIMAL PLACES			
3 DECIMAL PLACES ±0.015			
ANGULAR DEGREES ±1.5'	THIRD ANGLE PROJECTION		
	DO NOT SCALE DRAWING		

Amphenol Canada Corp. www.amphenolcanada.com	
TITLE MODULAR JACK, 8 CONTACTS, WITHOUT LEDS SHIELDED, .050" CONTACT TAIL SPACING, WITH GOLD PLATING OPTION- RoHS COMPLIANT	
DWG NO.	P-RJSBE-X380-C1
REV	A
CODE ID NO. 03554	DWG SIZE
SCALE	SHEET 1 OF 1