



MAX1179 Evaluation Kit

General Description

The MAX1179 evaluation kit (EV kit) is an assembled and tested circuit board that demonstrates the MAX1179 analog-to-digital converter. The EV kit can also be used to evaluate other Maxim devices in the same chip family. See Table 2 for more information. Free samples of alternate devices can be requested when ordering the MAX1179 EV kit.

Component List

DESIGNATION	QTY	DESCRIPTION
C1, C2	2	10 μ F, 10V X7R ceramic capacitors Taiyo Yuden LMK325BJ106MN
C3, C4, C5, C8, C9, C10	6	0.1 μ F ceramic capacitors
C6	1	10 μ F, 6.3V ceramic capacitor Taiyo Yuden JMK212BJ106MG
C7	1	0.01 μ F ceramic capacitor
C11, C12	2	10 μ F, 25V ceramic capacitors TDKC4532X7R1E106M
C7, R2	4	Socket-pin receptacles
H1	1	2 \times 16 dual-row vertical header
JU1–JU6	6	2-pin headers
R1	1	100k Ω \pm 5% resistor
R2	1	10 Ω \pm 5% resistor
U1	1	MAX1179BCUI
U2	1	Hex Schmitt trigger buffer 74HC14
U3	1	MAX427CSA
None	1	MAX1179 EV kit PC board

Component Supplier

SUPPLIER	PHONE	FAX	WEBSITE
Taiyo Yuden	800-348-2496	847-925-0899	www.t-yuden.com
TDK	847-803-6100	847-390-4405	www.component.tdk.com

Note: Indicate that you are using the MAX1179 when contacting these component suppliers.

Features

- ◆ Proven PC Board Layout
- ◆ Convenient On-Board Test Points
- ◆ Fully Assembled and Tested

Ordering Information

PART	TEMP RANGE	IC PACKAGE
MAX1179EVKIT	0°C to +70°C	28 TSSOP

Quick Start

Recommended Equipment

- MAX1179 EV kit
- Two DC power supplies, 5V at 10mA
- \pm 15V, 20mA power supply
- Programmable signal generator, such as Tektronix DG2020A
- Logic analyzer (optional)
- Reconstruction DAC (optional)

Procedure

The MAX1179 EV kit is fully assembled and tested. Follow these steps to verify board operation. **Do not turn on the power supply until all connections are completed.**

- 1) Ensure that JU1, JU2, and JU3 are open (see Table 1).
- 2) With the power off, connect the first 5VDC power supply between AVDD and AGND.
- 3) With the power off, connect the second 5VDC power supply between DVDD and DGND. **Note:** DGND and AGND are connected on the MAX1179 EV kit board. To avoid ground loops, do not connect AGND to DGND at any other location.
- 4) Configure the pattern generator to produce the appropriate read/convert (R/\overline{C}) and conversion start (\overline{CS}) waveforms. Refer to Figure 2 in the MAX1179 data sheet.
- 5) Connect the pattern generator \overline{CS} output across jumper JU4.
- 6) Connect the pattern generator R/\overline{C} output across jumper JU5.
- 7) Connect the logic analyzer or other digital data capture system to header H1. The least significant bit, D0, appears on H1 pin 1, and the end-of-conversion output strobe (EOC) appears across jumper JU6 (see Table 2).
- 8) Turn on the power supplies and enable the pattern generator.
- 9) Apply -5V to +5V analog input signal between pads AIN and AGND. Capture digital data from header H1.

Evaluates: MAX1156-MAX1159/74/75/77-79/87-89

MAX1179 Evaluation Kit

Detailed Description of Hardware

The MAX1179 (U1) is a single-channel, 16-bit data-acquisition system. Anti-alias filtering is performed by R2 and C7. The input signal can be applied directly to the AIN pad, or an optional MAX427 precision buffer (U3) can be used instead. Capacitors C4 and C6 bypass the reference. Schmitt trigger (U2) ensures proper system timing by keeping the \overline{CS} rising and falling edges clean.

Analog Input Buffer

When powered from $\pm 15V$ supplies, the analog input buffer (U3) has an input common-mode range of $\pm 12.5V$.

- 1) With the power off, connect the +15VDC power supply between BUF+15 and AGND.
- 2) With the power off, connect the -15VDC power supply between BUF-15 and AGND.
- 3) With the power off, connect the DC power-supply ground return to AGND.
- 4) Install a shunt across jumper JU3.
- 5) Apply the analog input signal to the BUFIN pad.

Generating a Crossplot

To see a visual indication of relative LSB size and DNL performance, create a crossplot fixture using a function generator, a latch, a resistor network, and an oscilloscope. Latch the data on the falling edge of \overline{EOC} . Connect the least significant bits together, using resistors of varying weights (for example, D0 = $75.0k\Omega \pm 1\%$, D1 = $39.1k\Omega \pm 1\%$, D2 = $20.0k\Omega \pm 1\%$, D3 = $10.0k\Omega \pm 1\%$, D4 = $4.99k\Omega \pm 1\%$). Drive the analog inputs with a linear ramping signal, such as a 100Hz triangle wave. Connect an oscilloscope in X-Y mode with X = analog input and Y = weighted sum of the latched digital outputs. The resulting staircase plot gives a visual indication of relative LSB sizes and DNL performance.

Evaluating Other Parts

The MAX1179 EV kit can be used to evaluate all the devices in Table 2. They offer various combinations of resolution, input range, and controller interface. Devices with an 8-bit interface shipped in a 20-pin package are mounted on the MAX1179, leaving pins 1–4 and 25–28 open. Request a sample of the optional device and replace the MAX1179 mounted on the kit.

Table 2 lists the various combinations.

Troubleshooting

Problem: no output measurement. System seems to report zero voltage, or fails to make a measurement.

- Check AVDD and DVDD supply voltages. Check the 4.096V reference voltage using a digital voltmeter. Use an oscilloscope to verify the R/C, \overline{CS} , and \overline{EOC} signals.
- Ensure that a resistor is installed in socket R2; otherwise, the analog input is unconnected.
- If using the input buffer U3, ensure that the $\pm 15V$ power supply is connected and JU3 is closed.

Problem: measurements are erratic, unstable; poor accuracy.

- Check the reference voltage using a digital voltmeter. Use an oscilloscope to check for noise. When probing for noise, keep the oscilloscope ground return lead as short as possible, preferably less than 0.5in (10mm).
- Increase the C6 and C7 capacitance. Short JU1 and apply an external 4.096V reference at REF to improve accuracy.
- Check for ground loops in the system.

MAX1179 Evaluation Kit

Evaluates: MAX1156-MAX1159/74/75/77-79/87-89

Table 1. Jumper Functions

JUMPER	FUNCTION
JU1	Leave JU1 open to enable the internal reference. Short JU1 when applying an external reference at REF.
JU2	Momentarily short JU2 to reset U1 (20-pin package units only). Leave JU2 open and apply high-byte enable signal (HBEN) at the RESET pad (20-pin package units only).
JU3	Short JU3 to drive analog input from MAX427 buffer U3. Leave JU3 open when driving AIN directly through R2.
JU4	Apply conversion start signal (\overline{CS}) across JU4.
JU5	Apply read/convert signal (R/\overline{C}) across JU5.
JU6	Obtain end-of-conversion (EOC) signal from JU6.

Table 2. Device Comparison

DEVICE	MAX1179	MAX1187	MAX1189	MAX1175	MAX1157	MAX1159	MAX1178	MAX1177	MAX1188	MAX1174	MAX1156	MAX1158
PACKAGE	28-Pin TSSOP						20-Pin TSSOP					
INTERFACE	16-Bit						8-Bit					
RESOLUTION	16-Bit			14-Bit			16-Bit			14-Bit		
INPUT RANGE	±5V	10V	±10V	±5V	10V	±10V	±5V	10V	±10V	±5V	10V	±10V
H1-1 SIGNAL	D0			Not Used			D0/D8			D0/D8		
H1-3 SIGNAL	D1			Not Used			D1/D9			D1/D9		
H1-5 SIGNAL	D2			D0			D2/D10			D2/D10		
H1-7 SIGNAL	D3			D1			D3/D11			D3/D11		
H1-9 SIGNAL	D4			D2			Not Used			Not Used		
H1-11 SIGNAL	D5			D3			Not Used			Not Used		
H1-13 SIGNAL	D6			D4			Not Used			Not Used		
H1-15 SIGNAL	D7			D5			Not Used			Not Used		
H1-17 SIGNAL	D8			D6			Not Used			Not Used		
H1-19 SIGNAL	D9			D7			Not Used			Not Used		
H1-21 SIGNAL	D10			D8			Not Used			Not Used		
H1-23 SIGNAL	D11			D9			Not Used			Not Used		
H1-25 SIGNAL	D12			D10			D4/D12			D4/D12		
H1-27 SIGNAL	D13			D11			D5/D13			D5/D13		
H1-29 SIGNAL	D14			D12			D6/D14			D6/D0		
H1-31 SIGNAL	D15			D13			D7/D15			D7/D0		
RESET/HBEN	Reset						HBEN					

MAX1179 Evaluation Kit

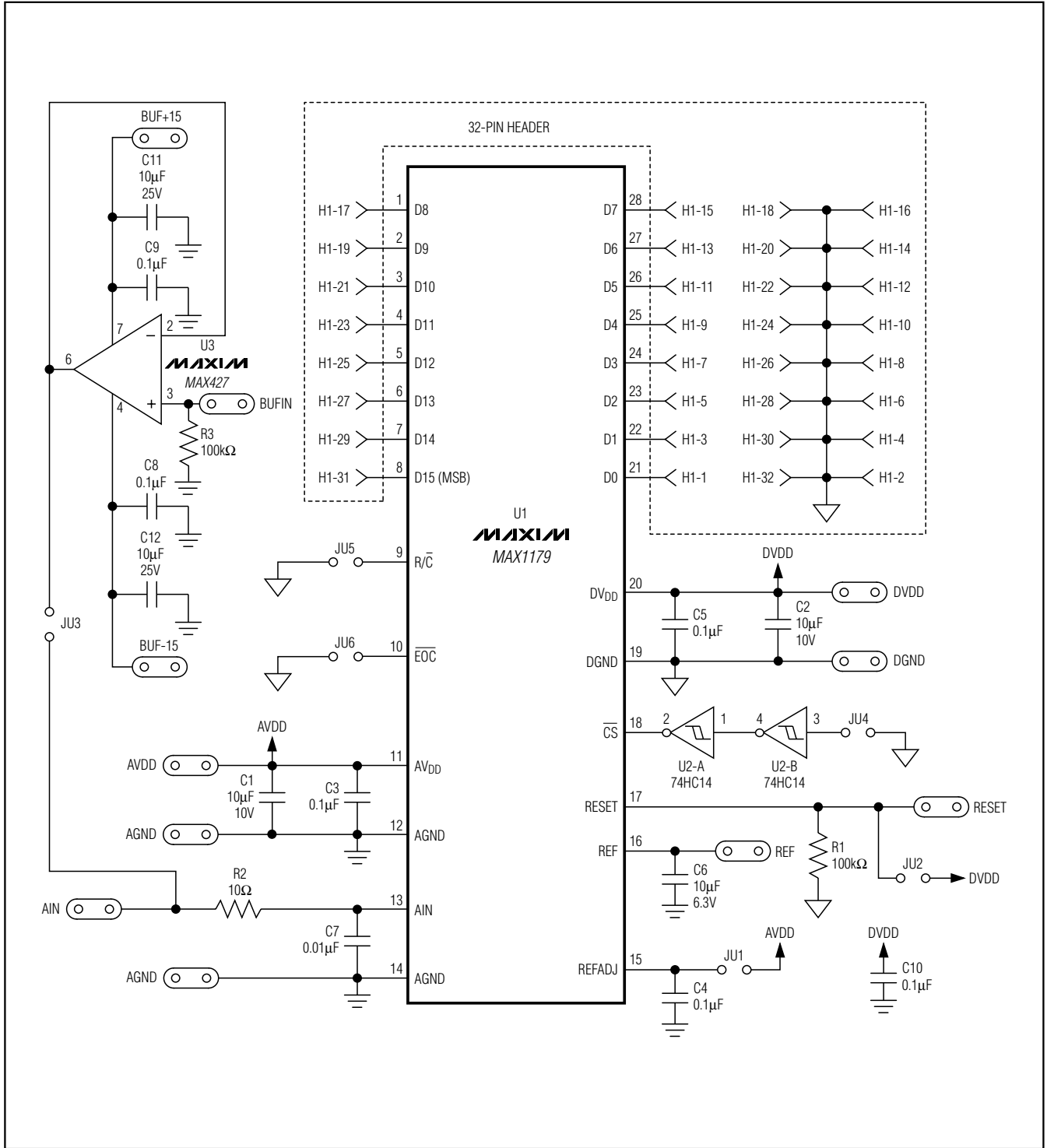

Figure 1. MAX1179 EV Kit Schematic

MAX1179 Evaluation Kit

Evaluates: MAX1156-MAX1159/74/75/77-79/87-89

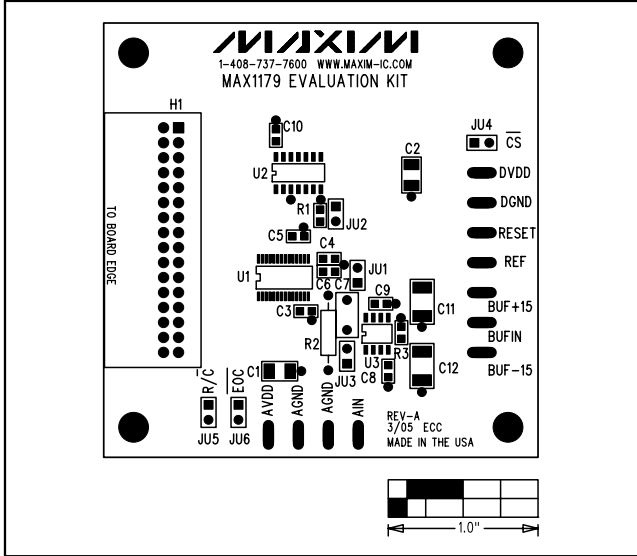

Figure 2. MAX1179 EV Kit Component Placement Guide—Component Side

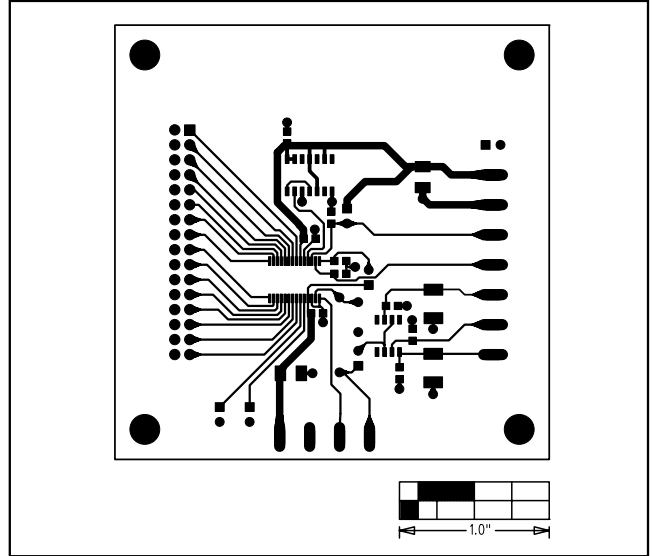

Figure 3. MAX1179 EV Kit PC Board Layout—Component Side

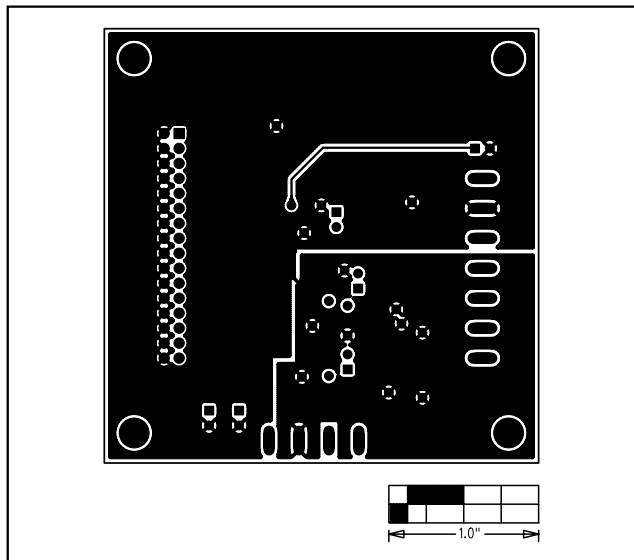

Figure 4. MAX1179 EV Kit PC Board Layout—Solder Side

Maxim cannot assume responsibility for use of any circuitry other than circuitry entirely embodied in a Maxim product. No circuit patent licenses are implied. Maxim reserves the right to change the circuitry and specifications without notice at any time.

Maxim Integrated Products, 120 San Gabriel Drive, Sunnyvale, CA 94086 408-737-7600 _____ 5