

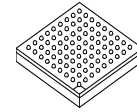

MCIMX53xC



Package Information

Plastic Package
Case HW-PWR-TEPBGA-529 19 x 19 mm,
0.8 mm pitch

Ordering Information

See [Table 1 on page 2](#)

i.MX53 Applications Processors for Industrial Products

Silicon Version 2.1

1 Introduction

The i.MX53 processor features ARM Cortex™-A8 core, which operates at clock speeds as high as 800 MHz. It provides DDR2/LVDDR2-800, LPDDR2-800, or DDR3-800 DRAM memories.

The flexibility of the i.MX53 architecture allows for its use in a wide variety of applications. As the heart of the application chipset, the i.MX53 processor provides all the interfaces for connecting peripherals, such as WLAN, Bluetooth™, GPS, hard drive, camera sensors, and dual displays.

Features of the i.MX53 processor include the following:

- Applications processor—The i.MX53xD processors boost the capabilities of high-tier portable applications by satisfying the ever increasing MIPS needs of operating systems and games. Freescale's Dynamic Voltage and Frequency Scaling (DVFS) provides significant power reduction, allowing the device to run at lower voltage and frequency with sufficient MIPS for tasks such as audio decode.

1	Introduction	1
1.1	Functional Part Differences and Ordering Information	
1.2	Features	3
2	Architectural Overview	6
2.1	Block Diagram	6
3	Modules List	7
3.1	Special Signal Considerations.	16
4	Electrical Characteristics	16
4.1	Chip-Level Conditions	16
4.2	Power Supply Requirements and Restrictions	23
4.3	I/O DC Parameters	26
4.4	Output Buffer Impedance Characteristics	32
4.5	I/O AC Parameters	36
4.6	System Modules Timing	43
4.7	External Peripheral Interfaces Parameters	65
4.8	XTAL Electrical Specifications	141
4.9	Integrated LDO Voltage Regulators Parameters	141
5	Boot Mode Configuration	142
5.1	Boot Mode Configuration Pins	142
5.2	Boot Devices Interfaces Allocation	143
5.3	Power Setup During Boot	144
6	Package Information and Contact Assignments	145
6.1	19x19 mm Package Information	145
7	Revision History	170



- **Multilevel memory system**—The multilevel memory system of the i.MX53 is based on the L1 instruction and data caches, L2 cache, internal and external memory. The i.MX53 supports many types of external memory devices, including DDR2, low voltage DDR2, LPDDR2, DDR3, NOR Flash, PSRAM, cellular RAM, NAND Flash (MLC and SLC), OneNAND™, and managed NAND including eMMC up to rev 4.4.
- **Smart speed technology**—The i.MX53 device has power management throughout the IC that enables the rich suite of multimedia features and peripherals to consume minimum power in both active and various low power modes. Smart speed technology enables the designer to deliver a feature-rich product requiring levels of power far lower than industry expectations.
- **Multimedia powerhouse**—The multimedia performance of the i.MX53 processor ARM core is boosted by a multilevel cache system, Neon (including advanced SIMD, 32-bit single-precision floating point support) and vector floating point coprocessors. The system is further enhanced by a multi-standard hardware video codec, autonomous image processing unit (IPU), and a programmable smart DMA (SDMA) controller.
- **Powerful graphics acceleration**— The i.MX53 processors provide two independent, integrated graphics processing units: an OpenGL® ES 2.0 3D graphics accelerator (33 Mtri/s, 200 Mpix/s, and 800 Mpix/s z-plane performance) and an OpenVG™ 1.1 2D graphics accelerator (200 Mpix/s).
- **Interface flexibility**—The i.MX53 processor supports connection to a variety of interfaces, including LCD controller for two displays and CMOS sensor interface, high-speed USB on-the-go with PHY, plus three high-speed USB hosts, multiple expansion card ports (high-speed MMC/SDIO host and others), 10/100 Ethernet controller, and a variety of other popular interfaces (PATA, UART, I²C, and I²S serial audio, among others).
- **Advanced security**—The i.MX53 processors deliver hardware-enabled security features that enable secure e-commerce, digital rights management (DRM), information encryption, secure boot, and secure software downloads. For detailed information about the i.MX53 security features contact a Freescale representative.

The i.MX53 application processor is a follow-on to the i.MX51, with improved performance, power efficiency, and multimedia capabilities.

1.1 Functional Part Differences and Ordering Information

shows the functional differences between the different parts in the i.MX53 family.

Table 1 provides ordering information.

Table 1. Ordering Information

Part Number	Mask Set	CPU Frequency	Notes	Package ¹
MCIMX537CVP8C2	3N78C	800 MHz	—	19 x 19 mm, 0.8 mm pitch BGA Case HW-PWR-TEPBGA-529

¹ Case TEPBGA-529 is RoHS compliant, lead-free MSL (moisture sensitivity level) 3.

1.2 Features

The i.MX53 multimedia applications processor (AP) is based on the ARM Platform, which has the following features:

- MMU, L1 instruction and L1 data cache
- Unified L2 cache
- Maximum frequency of the core (including Neon, VFPv3 and L1 cache): 800 MHz
- Neon coprocessor (SIMD media processing architecture) and vector floating point (VFP-Lite) coprocessor supporting VFPv3
- TrustZone

The memory system consists of the following components:

- Level 1 cache:
 - Instruction (32 Kbyte)
 - Data (32 Kbyte)
- Level 2 cache:
 - Unified instruction and data (256 Kbyte)
- Level 2 (internal) memory:
 - Boot ROM, including HAB (64 Kbyte)
 - Internal multimedia/shared, fast access RAM (128 Kbyte)
 - Secure/non-secure RAM (16 Kbyte)
- External memory interfaces:
 - 16/32-bit DDR2-800, LV-DDR2-800 or DDR3-800 up to 2 Gbyte
 - 32-bit LPDDR2
 - 8/16-bit NAND SLC/MLC Flash, up to 66 MHz, 4/8/14/16-bit ECC
 - 8/16-bit NOR Flash, PSRAM, and cellular RAM.
 - 32-bit multiplexed mode NOR Flash, PSRAM & cellular RAM.
 - 8-bit Asynchronous (DTACK mode) EIM interface.
 - All EIM pins are muxed on other interfaces (data with NFC pins). I/O muxing logic selects EIM port, as primary muxing at system boot.
 - Samsung OneNAND™ and managed NAND including eMMC up to rev 4.4 (in muxed I/O mode)

The i.MX53 system is built around the following system on chip interfaces:

- 64-bit AMBA AXI v1.0 bus—used by ARM platform, multimedia accelerators (such as VPU, IPU, GPU3D, GPU2D) and the external memory controller (EXTMC) operating at 200 MHz.
- 32-bit AMBA AHB 2.0 bus—used by the rest of the bus master peripherals operating at 133 MHz.
- 32-bit IP bus—peripheral bus used for control (and slow data traffic) of the most system peripheral devices operating at 66 MHz.

Introduction

The i.MX53 makes use of dedicated hardware accelerators to achieve state-of-the-art multimedia performance. The use of hardware accelerators provides both high performance and low power consumption while freeing up the CPU core for other tasks.

The i.MX53 incorporates the following hardware accelerators:

- VPU, version 3—video processing unit
- GPU3D—3D graphics processing unit, OpenGL ES 2.0, version 3, 33 Mtri/s, 200 Mpix/s, and 800 Mpix/s z-plane performance, 256 Kbyte RAM memory
- GPU2D—2D graphics accelerator, OpenVG 1.1, version 1, 200 Mpix/s performance,
- IPU, version 3M—image processing unit
- ASRC—asynchronous sample rate converter

The i.MX53 includes the following interfaces to external devices:

NOTE

Not all interfaces are available simultaneously, depending on I/O multiplexer configuration.

- Hard disk drives:
 - PATA, up to U-DMA mode 5, 100 MB/s
 - SATA II, 1.5 Gbps
- Displays:
 - Five interfaces available. Total rate of all interfaces is up to 180 Mpixels/s, 24 bpp. Up to two interfaces may be active at once.
 - Two parallel 24-bit display ports. The primary port is up to 165 Mpix/s (for example, UXGA at 60 Hz).
 - LVDS serial ports: one dual channel port up to 165 Mpix/s or two independent single channel ports up to 85 MP/s (for example, WXGA at 60 Hz) each.
 - TV-out/VGA port up to 150 Mpix/s (for example, 1080p60).
- Camera sensors:
 - Two parallel 20-bit camera ports. Primary up to 180-MHz peak clock frequency, secondary up to 120-MHz peak clock frequency.
- Expansion cards:
 - Four SD/MMC card ports: three supporting 416 Mbps (8-bit i/f) and one enhanced port supporting 832 Mbps (8-bit, eMMC 4.4).
- USB
 - High-speed (HS) USB 2.0 OTG (up to 480 Mbps), with integrated HS USB PHY
 - Three USB 2.0 (480 Mbps) hosts:
 - High-speed host with integrated on-chip high-speed PHY
 - Two high-speed hosts for external HS/FS transceivers through ULPI/serial, support IC-USB
- Miscellaneous interfaces:
 - One-wire (OWIRE) port

- Three I2S/SSI/AC97 ports, supporting up to 1.4 Mbps, each connected to audio multiplexer (AUDMUX) providing four external ports.
- Five UART RS232 ports, up to 4.0 Mbps each. One supports 8-wire, the other four support 4-wire.
- Two high speed enhanced CSPI (ECSPI) ports plus one CSPI port
- Three I²C ports, supporting 400 kbps
- Fast Ethernet controller, designed to be compliant with IEEE1588 V1, 10/100 Mbps
- Two controller area network (FlexCAN) interfaces, 1 Mbps each
- Sony Phillips Digital Interface (SPDIF), Rx and Tx
- Key pad port (KPP)
- Two pulse-width modulators (PWM)
- GPIO with interrupt capabilities

The system supports efficient and smart power control and clocking:

- Supporting DVFS (dynamic voltage and frequency scaling) technique for low power modes
- Power gating SRPG (State Retention Power Gating) for ARM core and Neon
- Support for various levels of system power modes
- Flexible clock gating control scheme
- On-chip temperature monitor
- On-chip oscillator amplifier supporting 32.768 kHz external crystal
- On-chip LDO voltage regulators for PLLs

Security functions are enabled and accelerated by the following hardware/features:

- ARM TrustZone including the TZ architecture (separation of interrupts, memory mapping, and so on)
- Secure JTAG controller (SJC)—Protecting JTAG from debug port attacks by regulating or blocking the access to the system debug features
- Secure real-time clock (SRTC)—Tamper resistant RTC with dedicated power domain and mechanism to detect voltage and clock glitches
- Real-time integrity checker, version 3 (RTICv3)—RTIC type1, enhanced with SHA-256 engine
- SAHARAv4 Lite—Cryptographic accelerator that includes true random number generator (TRNG)
- Security controller, version 2 (SCCv2)—Improved SCC with AES engine, secure/non-secure RAM and support for multiple keys as well as TZ/non-TZ separation
- Central security unit (CSU)—Enhancement for the IIM (IC Identification Module). CSU is configured during boot by eFUSES, and determines the security level operation mode as well as the TrustZone (TZ) policy
- Advanced High Assurance Boot (A-HAB)—HAB with the following embedded enhancements: SHA-256, 2048-bit RSA key, version control mechanism, warm boot, CSU, and TZ initialization
- Tamper detection mechanism—Provides evidence of any physical attempt to remove the device cover. Upon detection of such an attack, sensitive information can immediately be erased.

2 Architectural Overview

The following subsections provide an architectural overview of the i.MX53 processor system.

2.1 Block Diagram

Figure 1 shows the functional modules in the i.MX53 processor system.

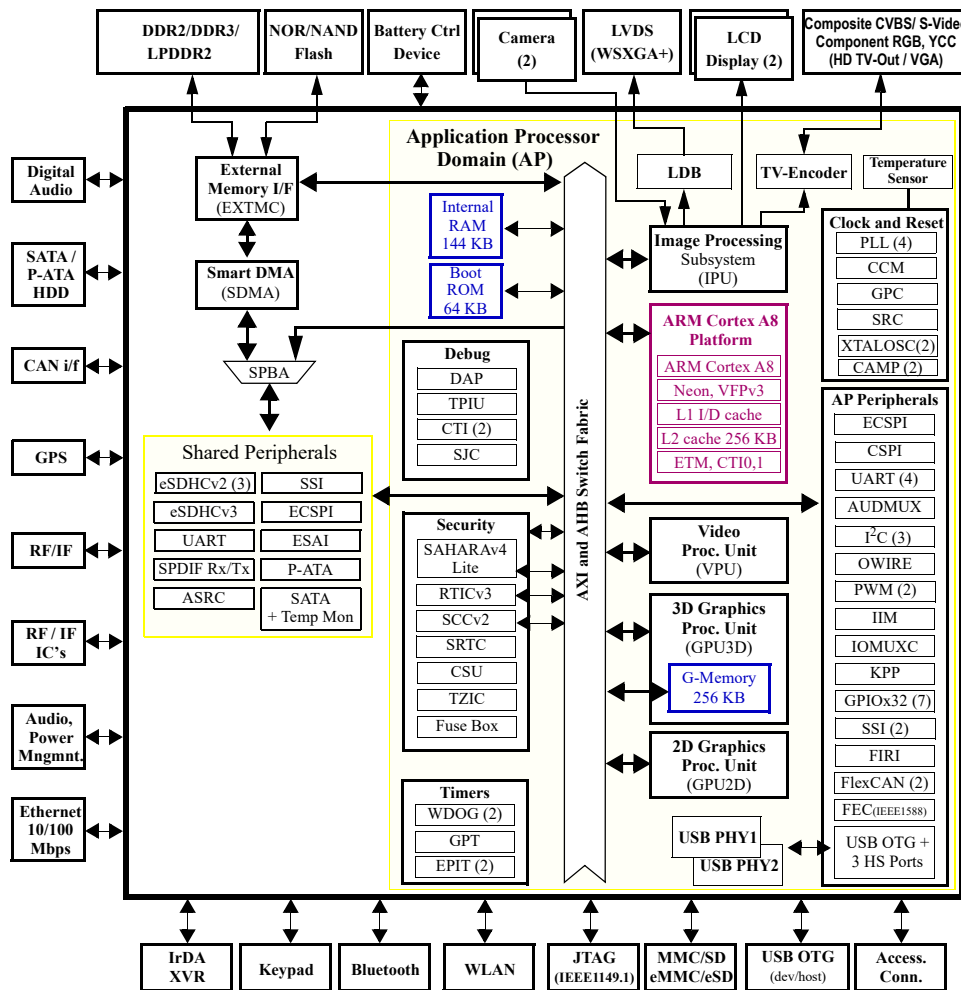

Figure 1. i.MX53 System Block Diagram

NOTE

The numbers in brackets indicate number of module instances. For example, PWM (2) indicates two separate PWM peripherals.

3 Modules List

The i.MX53 processor contains a variety of digital and analog modules. [Table 2](#) describes these modules in alphabetical order.

Table 2. i.MX53 Digital and Analog Blocks

Block Mnemonic	Block Name	Subsystem	Brief Description
ARM	ARM Platform	ARM	The ARM Cortex™ A8 platform consists of the ARM processor version r2p5 (with TrustZone) and its essential sub-blocks. It contains the 32 Kbyte L1 instruction cache, 32 Kbyte L1 data cache, Level 2 cache controller and a 256 Kbyte L2 cache. The platform also contains an event monitor and debug modules. It also has a NEON coprocessor with SIMD media processing architecture, a register file with 32/64-bit general-purpose registers, an integer execute pipeline (ALU, Shift, MAC), dual single-precision floating point execute pipelines (FADD, FMUL), a load/store and permute pipeline and a non-pipelined vector floating point (VFP Lite) coprocessor supporting VFPv3.
ASRC	Asynchronous Sample Rate Converter	Multimedia Peripherals	The asynchronous sample rate converter (ASRC) converts the sampling rate of a signal associated to an input clock into a signal associated to a different output clock. The ASRC supports concurrent sample rate conversion of up to 10 channels of about -120 dB THD+N. The sample rate conversion of each channel is associated to a pair of incoming and outgoing sampling rates. The ASRC supports up to three sampling rate pairs.
AUDMUX	Digital Audio Multiplexer	Multimedia Peripherals	The AUDMUX is a programmable interconnect for voice, audio, and synchronous data routing between host serial interfaces (for example, SSI1, SSI2, and SSI3) and peripheral serial interfaces (audio and voice codecs). The AUDMUX has seven ports (three internal and four external) with identical functionality and programming models. A desired connectivity is achieved by configuring two or more AUDMUX ports.
CAMP-1 CAMP-2	Clock Amplifier	Clocks, Resets, and Power Control	Clock amplifier
CCM GPC SRC	Clock Control Module Global Power Controller System Reset Controller	Clocks, Resets, and Power Control	These modules are responsible for clock and reset distribution in the system, as well as for system power management. The system includes four PLLs.
CSPI ECSPI-1 ECSPI-2	Configurable SPI, Enhanced CSPI	Connectivity Peripherals	Full-duplex enhanced synchronous serial interface, with data rates 16-60 Mbit/s. It is configurable to support master/slave modes. In Master mode it supports four slave selects for multiple peripherals.
CSU	Central Security Unit	Security	The central security unit (CSU) is responsible for setting comprehensive security policy within the i.MX53 platform, and for sharing security information between the various security modules. The security control registers (SCR) of the CSU are set during boot time by the high assurance boot (HAB) code and are locked to prevent further writing.

Table 2. i.MX53 Digital and Analog Blocks (continued)

Block Mnemonic	Block Name	Subsystem	Brief Description
DEBUG	Debug System	System Control	<p>The debug system provides real-time trace debug capability of both instructions and data. It supports a trace protocol that is an integral part of the ARM Real Time Debug solution (RealView).</p> <p>Real-time tracing is controlled by specifying a set of triggering and filtering resources, which include address and data comparators, three cross-system triggers (CTI), counters, and sequencers.</p> <p>debug access port (DAP)— The DAP provides real-time access for the debugger without halting the core to system memory, peripheral register, debug configuration registers and JTAG scan chains.</p>
EXTMC	External Memory Controller	Connectivity Peripherals	<p>The EXTMC is an external and internal memory interface. It performs arbitration between multi-AXI masters to multi-memory controllers, divided into four major channels, fast memories (DDR2/DDR3/LPDDR2) channel, slow memories (NOR-FLASH / PSRAM / NAND-FLASH etc.) channel, internal memory (RAM, ROM) channel and graphical memory (GMEM) channel.</p> <p>In order to increase the bandwidth performance, the EXTMC separates the buffering and the arbitration between different channels so parallel accesses can occur. By separating the channels, slow accesses do not interfere with fast accesses.</p> <p>EXTMC Features:</p> <ul style="list-style-type: none"> • 64-bit and 32-bit AXI ports • Enhanced arbitration scheme for fast channel, including dynamic master priority, and taking into account which pages are open or closed and what type (read or write) was the last access • Flexible bank interleaving • Support 16/32-bit DDR2-800 or DDR3-800 or LPDDR2. • Support up to 2 GByte DDR memories. • Support NFC, EIM signal muxing scheme. • Support 8/16/32-bit Nor-Flash/PSRAM memories (sync and async operating modes), at slow frequency. (8-bit is not supported on D[23]-D[16]). • Support 4/8/14/16-bit ECC, page sizes of 512-B, 2-KB and 4-KB Nand-Flash (including MLC) • Multiple chip selects (up to 4). • Enhanced DDR memory controller, supporting access latency hiding • Support watermark for security (internal and external memories)
EPIT-1 EPIT-2	Enhanced Periodic Interrupt Timer	Timer Peripherals	<p>Each EPIT is a 32-bit “set and forget” timer that starts counting after the EPIT is enabled by software. It is capable of providing precise interrupts at regular intervals with minimal processor intervention. It has a 12-bit prescaler for division of input clock frequency to get the required time setting for the interrupts to occur, and counter values can be programmed on the fly.</p>
ESAI	Enhanced Serial Audio Interface	Connectivity Peripherals	<p>The enhanced serial audio interface (ESAI) provides a full-duplex serial port for serial communication with a variety of serial devices, including industry-standard codecs, SPDIF transceivers, and other processors.</p> <p>The ESAI consists of independent transmitter and receiver sections, each section with its own clock generator.</p> <p>The ESAI has 12 pins for data and clocking connection to external devices.</p>

Table 2. i.MX53 Digital and Analog Blocks (continued)

Block Mnemonic	Block Name	Subsystem	Brief Description
ESDHCV3-3	Ultra-High-Speed eMMC / SD Host Controller	Connectivity Peripherals	Ultra high-speed eMMC / SD host controller, enhanced to support eMMC 4.4 standard specification, for 832 MBps. <ul style="list-style-type: none"> Port 3 is specifically enhanced to support eMMC 4.4 specification, for double data rate (832 Mbps, 8-bit port). ESDHCV3 is backward compatible to ESDHCV2 and supports all the features of ESDHCV2 as described below.
ESDHCV2-1 ESDHCV2-2 ESDHCv2-4	Enhanced Multi-Media Card / Secure Digital Host Controller		Enhanced multimedia card / secure digital host controller <ul style="list-style-type: none"> Ports 1, 2, and 4 are compatible with the "MMC System Specification" version 4.3, full support and supporting 1, 4 or 8-bit data. The generic features of the eSDHCv2 module, when serving as SD / MMC host, include the following: <ul style="list-style-type: none"> Can be configured either as SD / MMC controller Supports eSD and eMMC standard, for SD/MMC embedded type cards Conforms to SD Host Controller Standard Specification, version 2.0, full support. Compatible with the SD Memory Card Specification, version 1.1 Compatible with the SDIO Card Specification, version 1.2 Designed to work with SD memory, miniSD memory, SDIO, miniSDIO, SD Combo, MMC and MMC RS cards Configurable to work in one of the following modes: <ul style="list-style-type: none"> —SD/SDIO 1-bit, 4-bit —MMC 1-bit, 4-bit, 8-bit Full/high speed mode. Host clock frequency variable between 32 kHz to 52 MHz Up to 200 Mbps data transfer for SD/SDIO cards using 4 parallel data lines Up to 416 Mbps data transfer for MMC cards using 8 parallel data lines
FEC	Fast Ethernet Controller	Connectivity Peripherals	The Ethernet media access controller (MAC) is designed to support both 10 Mbps and 100 Mbps Ethernet/IEEE Std 802.3™ networks. An external transceiver interface and transceiver function are required to complete the interface to the media. The i.MX53 also consists of HW assist for IEEE1588™ standard. See, TSU and CE_RTC (IEEE1588) section for more details.
FIRI	Fast Infrared Interface	Connectivity Peripherals	Fast infrared interface
FLEXCAN-1 FLEXCAN-2	Flexible Controller Area Network	Connectivity Peripherals	The controller area network (CAN) protocol was primarily, but not exclusively, designed to be used as a vehicle serial data bus. Meets the following specific requirements of this application: real-time processing, reliable operation in the EXTMC environment of a vehicle, cost-effectiveness and required bandwidth. The FLEXCAN is a full implementation of the CAN protocol specification, Version 2.0 B (ISO 11898), which supports both standard and extended message frames at 1 Mbps.

Table 2. i.MX53 Digital and Analog Blocks (continued)

Block Mnemonic	Block Name	Subsystem	Brief Description
GPIO-1 GPIO-2 GPIO-3 GPIO-4 GPIO-5 GPIO-6 GPIO-7	General Purpose I/O Modules	System Control Peripherals	These modules are used for general purpose input/output to external ICs. Each GPIO module supports up to 32 bits of I/O.
GPT	General Purpose Timer	Timer Peripherals	Each GPT is a 32-bit “free-running” or “set and forget” mode timer with a programmable prescaler and compare and capture register. A timer counter value can be captured using an external event, and can be configured to trigger a capture event on either the leading or trailing edges of an input pulse. When the timer is configured to operate in “set and forget” mode, it is capable of providing precise interrupts at regular intervals with minimal processor intervention. The counter has output compare logic to provide the status and interrupt at comparison. This timer can be configured to run either on an external clock or on an internal clock.
GPU3D	Graphics Processing Unit	Multimedia Peripherals	The GPU, version 3, provides hardware acceleration for 2D and 3D graphics algorithms with sufficient processor power to run desk-top quality interactive graphics applications on displays up to HD1080 resolution. It supports color representation up to 32 bits per pixel. GPU enables high-performance mobile 3D and 2D vector graphics at rates up to 33 Mtriangles/s, 200 Mpix/s, 800 Mpix/s (z).
GPU2D	Graphics Processing Unit-2D	Multimedia Peripherals	The GPU2D version 1, provides hardware acceleration for 2D graphic algorithms with sufficient processor power to run desk-top quality interactive graphics applications on displays up to HD1080 resolution.
I2C-1 I2C-2 I2C-3	I ² C Controller	Connectivity Peripherals	I ² C provides serial interface for controlling peripheral devices. Data rates of up to 400 kbps are supported.
IIM	IC Identification Module	Security	<p>The IC identification module (IIM) provides an interface for reading, programming, and/or overriding identification and control information stored in on-chip fuse elements. The module supports electrically programmable poly fuses (e-Fuses). The IIM also provides a set of volatile software-accessible signals that can be used for software control of hardware elements not requiring non-volatility. The IIM provides the primary user-visible mechanism for interfacing with on-chip fuse elements. Among the uses for the fuses are unique chip identifiers, mask revision numbers, cryptographic keys, JTAG secure mode, boot characteristics, and various control signals requiring permanent non-volatility. The IIM also provides up to 28 volatile control signals. The IIM consists of a master controller, a software fuse value shadow cache, and a set of registers to hold the values of signals visible outside the module.</p> <p>IIM interfaces to the electrical fuse array (split to banks). Enabled to set up boot modes, security levels, security keys and many other system parameters.</p> <p>i.MX53A consists of 4 x 256-bit + 1 x 128-bit fuse-banks (total 1152 bits) through IIM interface.</p>

Table 2. i.MX53 Digital and Analog Blocks (continued)

Block Mnemonic	Block Name	Subsystem	Brief Description
IOMUXC	IOMUX Control	System Control Peripherals	This module enables flexible I/O multiplexing. Each I/O pad has default as well as several alternate functions. The alternate functions are software configurable.
IPU	Image Processing Unit	Multimedia Peripherals	Version 3M IPU enables connectivity to displays, relevant processing and synchronization. It supports two display ports and two camera ports, through the following interfaces: <ul style="list-style-type: none"> • Legacy parallel interfaces • Single/dual channel LVDS display interface • Analog TV or VGA interfaces The processing includes: <ul style="list-style-type: none"> • Image enhancement—color adjustment and gamut mapping, gamma correction and contrast enhancement • Video/graphics combining • Support for display backlight reduction • Image conversion—resizing, rotation, inversion and color space conversion • Hardware de-interlacing support • Synchronization and control capabilities, allowing autonomous operation.
KPP	Keypad Port	Connectivity Peripherals	The KPP supports an 8 × 8 external keypad matrix. The KPP features are as follows: <ul style="list-style-type: none"> • Open drain design • Glitch suppression circuit design • Multiple keys detection • Standby key press detection
LDB	LVDS Display Bridge	Connectivity Peripherals	LVDS display bridge is used to connect the IPU (image processing unit) to external LVDS display interface. LDB supports two channels; each channel has following signals: <ul style="list-style-type: none"> • 1 clock pair • 4 data pairs On-chip differential drivers are provided for each pair.
OWIRE	One-Wire Interface	Connectivity Peripherals	One-wire support provided for interfacing with an on-board EEPROM, and smart battery interfaces, for example, Dallas DS2502.
PATA	Parallel ATA	Connectivity Peripherals	The PATA block is a AT attachment host interface. Its main use is to interface with hard disk drives and optical disc drives. It interfaces with the ATA-6 compliant device over a number of ATA signals. It is possible to connect a bus buffer between the host side and the device side.
PWM-1 PWM-2	Pulse Width Modulation	Connectivity Peripherals	The pulse-width modulator (PWM) has a 16-bit counter and is optimized to generate sound from stored sample audio images. It can also generate tones. The PWM uses 16-bit resolution and a 4 x 16 data FIFO to generate sound.
INTRAM	Internal RAM	Internal Memory	Internal RAM, shared with VPU. The on-chip memory controller (OCRAM) module, is an interface between the system's AXI bus, to the internal (on-chip) SRAM memory module. It is used for controlling the 128 KB multimedia RAM, through a 64-bit AXI bus.
BOOTROM	Boot ROM	Internal Memory	Supports secure and regular boot modes. The ROM controller supports ROM patching.

Table 2. i.MX53 Digital and Analog Blocks (continued)

Block Mnemonic	Block Name	Subsystem	Brief Description
RTIC	Run-Time Integrity Checker	Security	Protecting read only data from modification is one of the basic elements in trusted platforms. The run-time integrity checker, version 3 (RTIC) block is a data-monitoring device responsible for ensuring that the memory content is not corrupted during program execution. The RTIC mechanism periodically checks the integrity of code or data sections during normal OS run-time execution without interfering with normal operation. The purpose of the RTIC is to ensure the integrity of the peripheral memory contents, protect against unauthorized external memory elements replacement and assist with boot authentication.
SAHARA	SAHARA Security Accelerator	Security	SAHARA (symmetric/asymmetric hashing and random accelerator), version 4, is a security coprocessor. It implements symmetric encryption algorithms, (AES, DES, 3DES, RC4 and C2), public key algorithms (RSA and ECC), hashing algorithms (MD5, SHA-1, SHA-224 and SHA-256), and a hardware true random number generator. It has a slave IP Bus interface for the host to write configuration and command information, and to read status information. It also has a DMA controller, with an AHB bus interface, to reduce the burden on the host to move the required data to and from memory.
SATA	Serial ATA	Connectivity Peripherals	SATA HDD interface, includes the SATA controller and the PHY. It is a complete mixed-signal IP solution for SATA HDD connectivity.
SCCv2	Security Controller, ver. 2	Security	The security controller is a security assurance hardware module designed to safely hold sensitive data, such as encryption keys, digital right management (DRM) keys, passwords and biometrics reference data. The SCCv2 monitors the system's alert signal to determine if the data paths to and from it are secure, that is, it cannot be accessed from outside of the defined security perimeter. If not, it erases all sensitive data on its internal RAM. The SCCv2 also features a key encryption module (KEM) that allows non-volatile (external memory) storage of any sensitive data that is temporarily not in use. The KEM utilizes a device-specific hidden secret key and a symmetric cryptographic algorithm to transform the sensitive data into encrypted data.
SDMA	Smart Direct Memory Access	System Control Peripherals	The SDMA is multi-channel flexible DMA engine. It helps in maximizing system performance by off loading various cores in dynamic data routing. The SDMA features list is as follows: <ul style="list-style-type: none"> • Powered by a 16-bit instruction-set micro-RISC engine • Multi-channel DMA supports up to 32 time-division multiplexed DMA channels • 48 events with total flexibility to trigger any combination of channels • Memory accesses including linear, FIFO, and 2D addressing • Shared peripherals between ARM and SDMA • Very fast context-switching with two-level priority-based preemptive multi-tasking • DMA units with auto-flush and prefetch capability • Flexible address management for DMA transfers (increment, decrement, and no address changes on source and destination address) • DMA ports can handle unidirectional and bidirectional flows (copy mode) • Up to 8-word buffer for configurable burst transfers to / from the EXTMC • Support of byte swapping and CRC calculations • A library of scripts and API is available

Table 2. i.MX53 Digital and Analog Blocks (continued)

Block Mnemonic	Block Name	Subsystem	Brief Description
SECRAM	Secure / Non-secure RAM	Internal Memory	Secure / non-secure Internal RAM, controlled by SCC.
SJC	Secure JTAG Interface	System Control Peripherals	JTAG manipulation is a known hacker's method of executing unauthorized program code, getting control over secure applications, and running code in privileged modes. The JTAG port provides a debug access to several hardware blocks including the ARM processor and the system bus. The JTAG port must be accessible during platform initial laboratory bring-up, manufacturing tests and troubleshooting, as well as for software debugging by authorized entities. However, in order to properly secure the system, unauthorized JTAG usage should be strictly forbidden. In order to prevent JTAG manipulation while allowing access for manufacturing tests and software debugging, the i.MX53 processor incorporates a mechanism for regulating JTAG access. SJC provides four different JTAG security modes that can be selected through an e-fuse configuration.
SPBA	Shared Peripheral Bus Arbiter	System Control Peripherals	SPBA (shared peripheral bus arbiter) is a two-to-one IP bus interface (IP bus) arbiter.
SPDIF	Sony Philips Digital Interface	Multimedia Peripherals	A standard digital audio transmission protocol developed jointly by the Sony and Philips corporations. Both transmitter and receiver functionalists are supported.
SRTC	Secure Real Time Clock	Security	The SRTC incorporates a special system state retention register (SSRR) that stores system parameters during system shutdown modes. This register and all SRTC counters are powered by dedicated supply rail NVCC_SRTC_POW. The NVCC_SRTC_POW can be energized separately even if all other supply rails are shut down. This register is helpful for storing warm boot parameters. The SSRR also stores the system security state. In case of a security violation, the SSRR mark the event (security violation indication).
SSI-1 SSI-2 SSI-3	I2S/SSI/AC97 Interface	Connectivity Peripherals	The SSI is a full-duplex synchronous interface used on the i.MX53A processor to provide connectivity with off-chip audio peripherals. The SSI interfaces connect internally to the AUDMUX for mapping to external ports. The SSI supports a wide variety of protocols (SSI normal, SSI network, I2S, and AC-97), bit depths (up to 24 bits per word), and clock/frame sync options. Each SSI has two pairs of 8 x 24 FIFOs and hardware support for an external DMA controller in order to minimize its impact on system performance. The second pair of FIFOs provides hardware interleaving of a second audio stream, which reduces CPU overhead in use cases where two time slots are being used simultaneously.

Table 2. i.MX53 Digital and Analog Blocks (continued)

Block Mnemonic	Block Name	Subsystem	Brief Description
IPTP	IEEE1588 Precision Time Protocol	Connectivity Peripherals	The IEEE 1588-2002 (version 1) standard defines a precision time protocol (PTP) - which is a time-transfer protocol that enables synchronization of networks (for example, Ethernet), to a high degree of accuracy and precision. The IEEE1588 hardware assist is composed of the two blocks: time stamp unit and real time clock, which provide the timestamping protocol's functionality, generating and reading the needed timestamps. The hardware-assisted implementation delivers more precise clock synchronization at significantly lower CPU load compared to purely software implementations.
Temperature Monitor	(Part of SATA Block)	System Control Peripherals	The temperature sensor is an internal module to the i.MX53 that monitors the die temperature. The monitor is capable in generating SW interrupt, or trigger the CCM, to reduce the core operating frequency.
TVE	TV Encoder	Multimedia	The TV encoder, version 2.1 is implemented in conjunction with the image processing unit (IPU) allowing handheld devices to display captured still images and video directly on a TV or LCD projector. It supports composite PAL/NTSC, VGA, S-video, and component up to HD1080p analog video outputs.
TZIC	TrustZone Aware Interrupt Controller	ARM/Control	The TrustZone interrupt controller (TZIC) collects interrupt requests from all i.MX53 sources and routes them to the ARM core. Each interrupt can be configured as a normal or a secure interrupt. Software Force Registers and software Priority Masking are also supported.
UART-1 UART-2 UART-3 UART-4 UART-5	UART Interface	Connectivity Peripherals	Each of the UART blocks supports the following serial data transmit/receive protocols and configurations: <ul style="list-style-type: none"> • 7 or 8-bit data words, 1 or 2 stop bits, programmable parity (even, odd, or none) • Programmable bit-rates up to 4 Mbps. This is a higher max baud rate relative to the 1.875 Mbps, which is specified by the TIA/EIA-232-F standard. • 32-byte FIFO on Tx and 32 half-word FIFO on Rx supporting auto-baud • IrDA 1.0 support (up to SIR speed of 115200 bps) • Option to operate as 8-pins full UART, DCE, or DTE
USB	USB Controller	Connectivity Peripherals	USB supports USB2.0 480 MHz, and contains: <ul style="list-style-type: none"> • One high-speed OTG sub-block with integrated HS USB PHY • One high-speed host sub-block with integrated HS USB PHY • Two identical high-speed Host modules The high-speed OTG module, which is internally connected to the HS USB PHY, is equipped with transceiver-less logic to enable on-board USB connectivity without USB transceivers All the USB ports are equipped with standard digital interfaces (ULPI, HS IC-USB) and transceiver-less logic to enable onboard USB connectivity without USB transceivers.

Table 2. i.MX53 Digital and Analog Blocks (continued)

Block Mnemonic	Block Name	Subsystem	Brief Description
VPU	Video Processing Unit	Multimedia Peripherals	<p>A high-performing video processing unit (VPU) version 3, which covers many SD-level video decoders and SD-level encoders as a multi-standard video codec engine as well as several important video processing such as rotation and mirroring.</p> <p>VPU Features:</p> <ul style="list-style-type: none"> • MPEG-2 decode, Main-High profile, up to 1080i/p resolution, 40 Mbps bit rate • MPEG4/XviD decode, SP/ASP profile, up to 1080 i/p resolution, 40 Mbps bit rate • H.263 decode, P0/P3 profile, up to 16CIF resolution, 20 Mbps bit rate • H.264 decode, BP/MP/HP profile, up to 1080 i/p resolution, 40 Mbps bit rate • VC1 decode, SP/MP/AP profile, up to 1080 i/p resolution, 40 Mbps bit rate • RV10 decode, 8/9/2010 profile, up to 1080 i/p resolution, 40 Mbps bit rate • DivX decode, 3/4/5/6 profile, up to 1080 i/p resolution, 40 Mbps bit rate • MJPEG decode, Baseline profile, up to 8192 x 8192 resolution, 40 Mpixel/s bit rate for 4:4:4 format • MPEG4 encode, Simple profile, up to 720p resolution, 12 Mbps bit rate¹ • H.263 encode, P0/P3 profile, up to 4CIF resolution, 8 Mbps bit rate¹ • H.264 encode, Baseline profile, up to 720p resolution, 14 Mbps bit rate¹ • MJPEG encode, Baseline profile, up to 8192 x 8192 resolution, 80 Mpixel/s bit rate for 4:2:2 format
WDOG-1	Watch Dog	Timer Peripherals	The watch dog timer supports two comparison points during each counting period. Each of the comparison points is configurable to evoke an interrupt to the ARM core, and a second point evokes an external event on the WDOG line.
WDOG-2 (TZ)	Watch Dog (TrustZone)	Timer Peripherals	The TrustZone watchdog (TZ WDOG) timer module protects against TrustZone starvation by providing a method of escaping normal mode and forcing a switch to the TZ mode. TZ starvation is a situation where the normal OS prevents switching to the TZ mode. This situation should be avoided, as it can compromise the system's security. Once the TZ WDOG module is activated, it must be serviced by TZ software on a periodic basis. If servicing does not take place, the timer times out. Upon a time-out, the TZ WDOG asserts a TZ mapped interrupt that forces switching to the TZ mode. If it is still not served, the TZ WDOG asserts a security violation signal to the CSU. The TZ WDOG module cannot be programmed or deactivated by a normal mode SW.
XTALOSC	24 MHz Crystal Oscillator	Clocking	Provides a crystal oscillator amplifier that supports a 24 MHz external crystal
XTALOSC_32K	32.768 kHz Crystal Oscillator I/F	Clocking	Provides a crystal oscillator amplifier that supports a 32.768 kHz external crystal.

¹ VPU can generate higher bit rate than the maximum specified by the corresponding standard.

3.1 Special Signal Considerations

The package contact assignments can be found in [Section 6, “Package Information and Contact Assignments.”](#) Signal descriptions are defined in the i.MX53 Reference Manual. Special signal considerations information is contained in Chapter 1 of *i.MX53 System Development User's Guide* (MX53UG).

4 Electrical Characteristics

This section provides the device and module-level electrical characteristics for the i.MX53 processor.

4.1 Chip-Level Conditions

This section provides the device-level electrical characteristics for the IC. See [Table 4](#) for a quick reference to the individual tables and sections.

Table 4. i.MX53 Chip-Level Conditions

For these characteristics, ...	Topic appears ...
Absolute Maximum Ratings	Table 5 on page 16
TEPBGA-529 Package Thermal Resistance Data	Table 6 on page 17
i.MX53 Operating Ranges	Table 7 on page 18
External Clock Sources	Table 8 on page 20
Maximal Supply Currents	Table 9 on page 20
USB Interface Current Consumption	Table 10 on page 23

4.1.1 Absolute Maximum Ratings

CAUTION

Stresses beyond those listed under [Table 5](#) may affect reliability or cause permanent damage to the device. These are stress ratings only. Functional operation of the device at these or any other conditions beyond those indicated in the Operating Ranges table is not implied.

Table 5. Absolute Maximum Ratings

Parameter Description	Symbol	Min	Max	Unit
Peripheral Core Supply Voltage	VCC	-0.3	1.35	V
ARM Core Supply Voltage	VDDGP	-0.3	1.4	V
Supply Voltage UHVIO	Supplies denoted as I/O Supply	-0.5	3.6	V
Supply Voltage for non UHVIO	Supplies denoted as I/O Supply	-0.5	3.3	V
USB VBUS	VBUS	—	5.25	V

Table 5. Absolute Maximum Ratings (continued)

Parameter Description	Symbol	Min	Max	Unit
Input voltage on USB_OTG_DP, USB_OTG_DN, USB_H1_DP, USB_H1_DN pins	USB_DP/USB_DN	-0.3	3.63 ¹	V
Input/Output Voltage Range	V_{in}/V_{out}	-0.5	OVDD +0.3 ²	V
ESD Damage Immunity: • Human Body Model (HBM) • Charge Device Model (CDM)	V_{esd}	— —	2000 500	V
Storage Temperature Range	$T_{STORAGE}$	-40	150	°C

¹ USB_DN and USB_DP can tolerate 5 V for up to 24 hours.

² The term OVDD in this section refers to the associated supply rail of an input or output. The association is described in Table 114 on page 148. The maximum range can be superseded by the DC tables.

4.1.2 Thermal Resistance

4.1.2.1 TEPBGA-529 Package Thermal Resistance

Table 6 provides the TEPBGA-529 package thermal resistance data.

Table 6. TEPBGA-529 Package Thermal Resistance Data

Rating	Board	Symbol	Value	Unit
Junction to Ambient (natural convection) ^{1, 2}	Single layer board (1s)	$R_{\theta JA}$	28	°C/W
Junction to Ambient (natural convection) ^{1, 2, 3}	Four layer board (2s2p)	$R_{\theta JA}$	16	°C/W
Junction to Ambient (at 200 ft/min) ^{1, 3}	Single layer board (1s)	$R_{\theta JMA}$	21	°C/W
Junction to Ambient (at 200 ft/min) ^{1, 3}	Four layer board (2s2p)	$R_{\theta JMA}$	13	°C/W
Junction to Board ⁴	—	$R_{\theta JB}$	6	°C/W
Junction to Case ⁵	—	$R_{\theta JC}$	4	°C/W
Junction to Package Top (natural convection) ⁶	—	Ψ_{JT}	4	°C/W

¹ Junction temperature is a function of die size, on-chip power dissipation, package thermal resistance, mounting site (board) temperature, ambient temperature, air flow, power dissipation of other components on the board, and board thermal resistance.

² Per JEDEC JESD51-2 with the single layer board horizontal. Board meets JESD51-9 specification.

³ Per JEDEC JESD51-6 with the board horizontal.

⁴ Thermal resistance between the die and the printed circuit board per JEDEC JESD51-8. Board temperature is measured on the top surface of the board near the package.

⁵ Thermal resistance between the die and the case top surface as measured by the cold plate method (MIL SPEC-883 Method 1012.1).

⁶ Thermal characterization parameter indicating the temperature difference between package top and the junction temperature per JEDEC JESD51-2.

4.1.3 Operating Ranges

Table 7 provides the operating ranges of i.MX53 processor.

Table 7. i.MX53 Operating Ranges

Symbol	Parameter	Minimum ¹	Nominal ²	Maximum ¹	Unit
VDDGP ³	ARM core supply voltage $f_{\text{ARM}} \leq 400$ MHz	0.9	0.95	1.15	V
	ARM core supply voltage $f_{\text{ARM}} \leq 800$ MHz	1.05	1.1	1.15	V
	ARM core supply voltage Stop mode	0.8	0.85	1.15	V
VCC	Peripheral supply voltage ⁴	1.25	1.3	1.35	V
	Peripheral supply voltage—Stop mode	0.9	0.95	1.35	V
VDDA ⁵	Memory arrays voltage	1.25	1.30	1.35	V
	Memory arrays voltage—Stop mode	0.9	0.95	1.35	V
VDDAL1 ⁵	L1 Cache Memory arrays voltage	1.25	1.30	1.35	V
	L1 Cache Memory arrays voltage—Stop mode	0.9	0.95	1.35	V
VDD_DIG_PLL ⁶	PLL Digital supplies—external regulator option	1.25	1.3	1.35	V
VDD_ANA_PLL ⁷	PLL Analog supplies—external regulator option	1.75	1.8	1.95	V
NVCC_CKIH	ESD protection of the CKIH pins, FUSE read Supply and 1.8V bias for the UHVIO pads	1.65	1.8	1.95	V
NVCC_LCD NVCC_JTAG	GPIO digital power supplies	1.65	1.8 or 2.775	3.1	V
NVCC_LVDS	LVDS interface Supply	2.375	2.5	2.75	V
NVCC_LVDS_BG	LVDS Band Gap Supply	2.375	2.5	2.75	V
NVCC_EMI_DRAM	DDR Supply DDR2 range	1.7	1.8	1.9	V
	DDR Supply LPDDR2 range	1.14	1.2	1.3	
	DDR Supply LV-DDR2 range	1.47	1.55	1.63	
		1.42	1.5	1.58	
	DDR Supply DDR3 range	1.42	1.5	1.58	
VDD_FUSE ⁸	Fusebox Program Supply (Write Only)	3.0	—	3.3	V
NVCC_NANDF NVCC_SD1 NVCC_SD2 NVCC_PATA NVCC_KEYPAD NVCC_GPIO NVCC_FEC NVCC_EIM_MAIN NVCC_EIM_SEC NVCC_CSI	Ultra High voltage I/O (UHVIO) supplies: • UHVIO_L • UHVIO_H • UHVIO_UH	1.65	1.8	1.95	V
		2.5	2.775	3.1	
		3.0	3.3	3.6	

Table 7. i.MX53 Operating Ranges (continued)

Symbol	Parameter	Minimum ¹	Nominal ²	Maximum ¹	Unit
TVDAC_DHVDD ⁹ TVDAC_AHVDDRGB ⁹	TVE digital and analog power supply, TVE-to-DAC level shifter supply, cable detector supply, analog power supply to RGB channel	2.69	2.75	2.91	V
	For GPIO use only, when TVE is not in use	1.65	1.8 or 2.775	3.1	V
NVCC_SRTC_POW	SRTC Core and slow I/O Supply (GPIO) ¹⁰	1.25	1.3	1.35	V
NVCC_RESET	LVIO	1.65	1.8 or 2.775	3.1	V
USB_H1_VDDA25 USB_OTG_VDDA25 NVCC_XTAL	USB_PHY analog supply, oscillator amplifier analog supply ¹¹	2.25	2.5	2.75	V
USB_H1_VDDA33 USB_OTG_VDDA33	USB PHY I/O analog supply	3.0	3.3	3.6	V
VBUS	See Table 5 on page 16 and Table 107 on page 141 for details. Note that this is not a power supply.	—	—	—	—
VDD_REG ¹²	Power supply input for the integrated linear regulators	2.37	2.5	2.63	V
VP	SATA PHY core power supply	1.25	1.3	1.35	V
VPH	SATA PHY I/O supply voltage	2.25	2.5	2.75	V
T _J	Junction temperature	-40	105 ¹³	125	°C

¹ Voltage at the package power supply contact must be maintained between the minimum and maximum voltages. The design must allow for supply tolerances and system voltage drops.

² The nominal values for the supplies indicate the target setpoint for a tolerance no tighter than ± 50 mV. Use of supplies with a tighter tolerance allows reduction of the setpoint with commensurate power savings.

³ A voltage transition is allowed for the required supply ramp up to the nominal value prior to achieving a clock speed increase. Similarly, to accommodate a frequency reduction, a voltage transition is allowed for a supply ramp down to the nominal value after the frequency is decreased.

⁴ For BSDL mode, the minimum operating temperature is 20 °C and the maximum operating temperature is the maximum temperature specified for the particular part grade.

⁵ VDDA and VDDAL1 can be driven by the VDD_DIG_PLL internal regulator using external connections. When operating in this configuration, the regulator is still operating at the default 1.2 V, as bootup start. During bootup initialization, software should increase this regulator voltage to match VCC (1.3 V nominal) in order to reduce internal leakage current.

⁶ By default, VDD_DIG_PLL is driven from internal on-die 1.2 V linear regulator (LDO). In this case, there is no need driving this supply externally. LDO output to VDD_DIG_PLL should be configured by software after power-up to 1.3 V output. A bypass capacitor of minimal value 22 μ F should be connected to this pad in any case whether it is driven internally or externally. Use of the on-chip LDO is preferred. See i.MX53 System Development User's Guide.

⁷ By default, the VDD_ANA_PLL is driven from internal on-die 1.8 V linear regulator (LDO). In this case there is no need driving this supply externally. A bypass capacitor of minimal value 22 μ F should be connected to this pad in any case whether it is driven internally or externally. Use of the on-chip LDO is preferred. See i.MX53 System Development User's Guide.

⁸ After fuses are programmed, Freescale strongly recommends the best practice of reading the fuses to verify that they are written correctly. In Read mode, VDD_FUSE should be floated or grounded. Tying VDD_FUSE to a positive supply (3.0 V–3.3 V) increases the possibility of inadvertently blowing fuses and is not recommended in read mode.

⁹ If not using the TVE module or other pads in this power domain for the product, the TVDAC_DHVDD and TVDAC_AHVDDRGB can be kept floating or tied to GND—the recommendation is to float.

¹⁰ GPIO pad operational at low frequency

Electrical Characteristics

- ¹¹ The analog supplies should be isolated in the application design. Use of series inductors is recommended.
- ¹² VDD_REG is power supply input for the integrated linear regulators of VDD_ANA_PLL and VDD_DIG_PLL when they are configured to the internal supply option. VDDR_REG still has to be tied to 2.5 V supply when VDD_ANA_PLL and VDD_DIG_PLL are configured for external power supply mode although in this case it is not used as supply source.
- ¹³ Lifetime of 87,600 hours based on 105 °C junction temperature at nominal supply voltages.

4.1.4 External Clock Sources

The i.MX53 device has four external input system clocks, a low frequency (CKIL), a high frequency (XTAL), and two general purpose CKIH1 and CKIH2 clocks.

The CKIL is used for low-frequency functions. It supplies the clock for wake-up circuit, power-down real time clock operation, and slow system and watch-dog counters. The clock input can be connected to either external oscillator or a crystal using internal oscillator amplifier.

The system clock input XTAL is used to generate the main system clock. It supplies the PLLs and other peripherals. The system clock input can be connected to either external oscillator or a crystal using internal oscillator amplifier.

CKIH1 and CKIH2 provide additional clock source option for peripherals that require specific and accurate frequencies.

[Table 8](#) shows the interface frequency requirements. See Chapter 1 of *i.MX53 System Development User's Guide* (MX53UG) for additional clock and oscillator information.

Table 8. External Input Clock Frequency

Parameter Description	Symbol	Min	Typ	Max	Unit
CKIL Oscillator ¹	f _{ckil}	—	32.768 ² /32.0	—	kHz
CKIH1, CKIH2 Operating Frequency	f _{ckih1} , f _{ckih2}	See Table 33, "CAMP Electrical Parameters (CKIH1, CKIH2)," on page 44			MHz
XTAL Oscillator	f _{xtal}	22	24	27	MHz

¹ External oscillator or a crystal with internal oscillator amplifier.

² Recommended nominal frequency 32.768 kHz.

4.1.5 Maximal Supply Currents

[Table 9](#) represents the maximal momentary current transients on power lines, and should be used for power supply selection. Maximal currents higher by far than the average power consumption of typical use cases. For typical power consumption information, see i.MX53 power consumption application note.

Table 9. Maximal Supply Currents

Power Line	Conditions	Max Current	Unit
VDDGP	800 MHz ARM clock	1450	mA
VCC		800	mA
VDDA+VDDAL1		100	mA
VDD_DIG_PLL		10	mA

Table 9. Maximal Supply Currents (continued)

Power Line	Conditions	Max Current	Unit
VP		20	mA
VDD_ANA_PLL		10	mA
NVCC_XTAL		25	mA
VDD_REG		325	mA
VDD_FUSE	Fuse Write Mode operation	120	mA
NVCC_EMI_DRAM ¹	1.8V (DDR2)	800	mA
	1.5V (DDR3)	650	mA
	1.2V (LPDDR2)	250	mA
TVDAC_DHVDD + TVDAC_AHVDDRGB		200	mA
NVCC_SRTC_POW		50 ²	μA
USB_H1_VDDA25 + USB_OTG_VDDA25		50	mA
USB_H1_VDDA33 + USB_OTG_VDDA33		20	mA
VPH		60	mA
NVCC_CKIH		Use maximal I/O Eq ³ , N=4	
NVCC_CSI		Use maximal I/O Eq ³ , N=20	
NVCC_EIM_MAIN		Use maximal I/O Eq ³ , N=39	
NVCC_EIM_SEC		Use maximal I/O Eq ³ , N=16	
NVCC_FEC		Use maximal I/O Eq ³ , N=11	
NVCC_GPIO		Use maximal I/O Eq ³ , N=13	
NVCC_JTAG		Use maximal I/O Eq ³ , N=6	
NVCC_KPAD		Use maximal I/O Eq ³ , N=11	
NVCC_LCD		Use maximal I/O Eq ³ , N=29	
NVCC_LVDS		Use maximal I/O Eq ³ , N=20	
NVCC_LVDS_BG		Use maximal I/O Eq ³ , N=1	
NVCC_NANDF		Use maximal I/O Eq ³ , N=8	
NVCC_PATA		Use maximal I/O Eq ³ , N=29	
NVCC_REST		Use maximal I/O Eq ³ , N=5	

Table 9. Maximal Supply Currents (continued)

Power Line	Conditions	Max Current	Unit
NVCC_SD1		Use maximal I/O Eq ³ , N=6	
NVCC_SD2		Use maximal I/O Eq ³ , N=6	

¹ The results are based on calculation assuming the following conditions:

- Four 16-bit DDR devices
- Heavy use profile
- On-Die Termination (ODT) of 50 Ω for DDR2 and 40 Ω for DDR3
- Dual rank termination schema
- Command and Address line termination to NVCC_EMI_DRAM/2 voltage

These numbers include both i.MX53 DDR controller I/O current consumption and DDR memory I/O power consumption for data and DQS lines.

² 50 μA current is the worst case for fast silicon at 125 °C. The typical current is 3 μA for typical silicon at 25 °C.

³ General Equation for estimated, maximal power consumption of an I/O power supply:

$$I_{max} = N \times C \times V \times (0.5 \times F)$$

Where:

N - Number of I/O pins supplies by the power line

C - Equivalent external capacitive load

V - I/O voltage

(0.5 x F) - Data change rate. Up to 0.5 of the clock rate (F).

4.1.6 USB-OH-3 (OTG + 3 Host ports) Module and the Two USB PHY (OTG and H1) Current Consumption

Table 10 shows the USB interface current consumption.

Table 10. USB Interface Current Consumption

Parameter	Conditions		Typical at 25 °C	Max	Unit
Analog Supply 3.3 V USB_H1_VDDA33 USB_OTG_VDDA33	Full Speed	RX	5.5	6	mA
		TX	7	8	
	High Speed	RX	5	6	
		TX	5	6	
Analog Supply 2.5 V USB_H1_VDDA25 USB_OTG_VDDA25	Full Speed	RX	6.5	7	mA
		TX	6.5	7	
	High Speed	RX	12	13	
		TX	21	22	
Digital Supply VCC (1.2 V)	Full Speed	RX	8	—	mA
		TX	8	—	
	High Speed	RX	8	—	
		TX	8	—	

4.2 Power Supply Requirements and Restrictions

The system design must comply with power-up sequence, power-down sequence and steady state guidelines as described in this section to guarantee the reliable operation of the device. Any deviation from these sequences may result in the following situations:

- Excessive current during power-up phase
- Prevention of the device from booting
- Irreversible damage to the i.MX53 processor (worst-case scenario)

4.2.1 Power-Up Sequence

The following observations should be considered:

- The consequent steps in power up sequence should not start before the previous step supplies have been stabilized within 90-110% of their nominal voltage, unless stated otherwise.
- NVCC_SRTC_POW should remain powered ON continuously, to maintain internal real-time clock status. Otherwise, it has to be powered ON together with VCC, or preceding VCC.
- The VCC should be powered ON together, or any time after NVCC_SRTC_POW.
- NVCC_CKIH should be powered ON after VCC is stable and before other I/O supplies (NVCC_XXX) are powered ON.

- I/O Supplies (NVCC_xxx) below or equal to 2.8 V nom./3.1 V max. should not precede NVCC_CKIH. They can start powering ON during NVCC_CKIH ramp-up, before it is stabilized. Within this group, the supplies can be powered-up in any order. Alternatively, the on-chip regulator VDD_ANA_PLL can be used to power NVCC_CKIH and NVCC_RESET. In this case, the sequence defined in the “Interfacing the i.MX53 Processor with LTC3589-1” section of the *i.MX53 System Development User's Guide* (MX53UG) must be followed.
- I/O Supplies (NVCC_xxx) above 2.8 V nom./3.1 V max. should be powered ON only after NVCC_CKIH is stable.
- In case VDD_DIG_PLL and VDD_ANA_PLL are powered ON from internal voltage regulator (default case for i.MX53), there are no related restrictions on VDD_REG, as it is used as their internal regulators power source.
If VDD_DIG_PLL and VDD_ANA_PLL are powered on externally, to reduce current leakage during the power-up, it is recommended to activate the VDD_REG before or at the same time with VDD_DIG_PLL and VDD_ANA_PLL. If this sequencing is not possible, make sure that the 2.5 V VDD_REG supply shut-off output impedance is higher than 1 k Ω when it is inactive.
- VDD_REG supply is required to be powered ON to enable DDR operation. It must be powered on after VCC and before NVCC_EMI_DRAM. The sequence should be:
$$VCC \rightarrow VDD_REG \rightarrow NVCC_EMI_DRAM$$
- If SRTC is not used, VDDA and VDDAL1 can be powered ON anytime before POR_B, regardless of any other power signal.
- When SRTC is used, VDDA and VDDAL1 must be powered on before VDD_REG.
- VDDGP can be powered ON anytime before POR_B, regardless of any other power signal.
- VP and VPH can be powered up together, or anytime after, the VCC. VP and VPH should come before POR.
- TVDAC_DHVDD and TVDAC_AHVDDRGB should be powered from the same regulator. This is due to ESD diode protection circuit, that may cause current leakage if one of the supplies is powered ON before the other.

NOTE

The POR_B input must be immediately asserted at power-up and remain asserted until after the last power rail reaches its working voltage.

NOTE

If NVCC_RESET power is removed or interrupted, a power-on reset is generated.

Figure 2 shows the power-up sequence diagram.

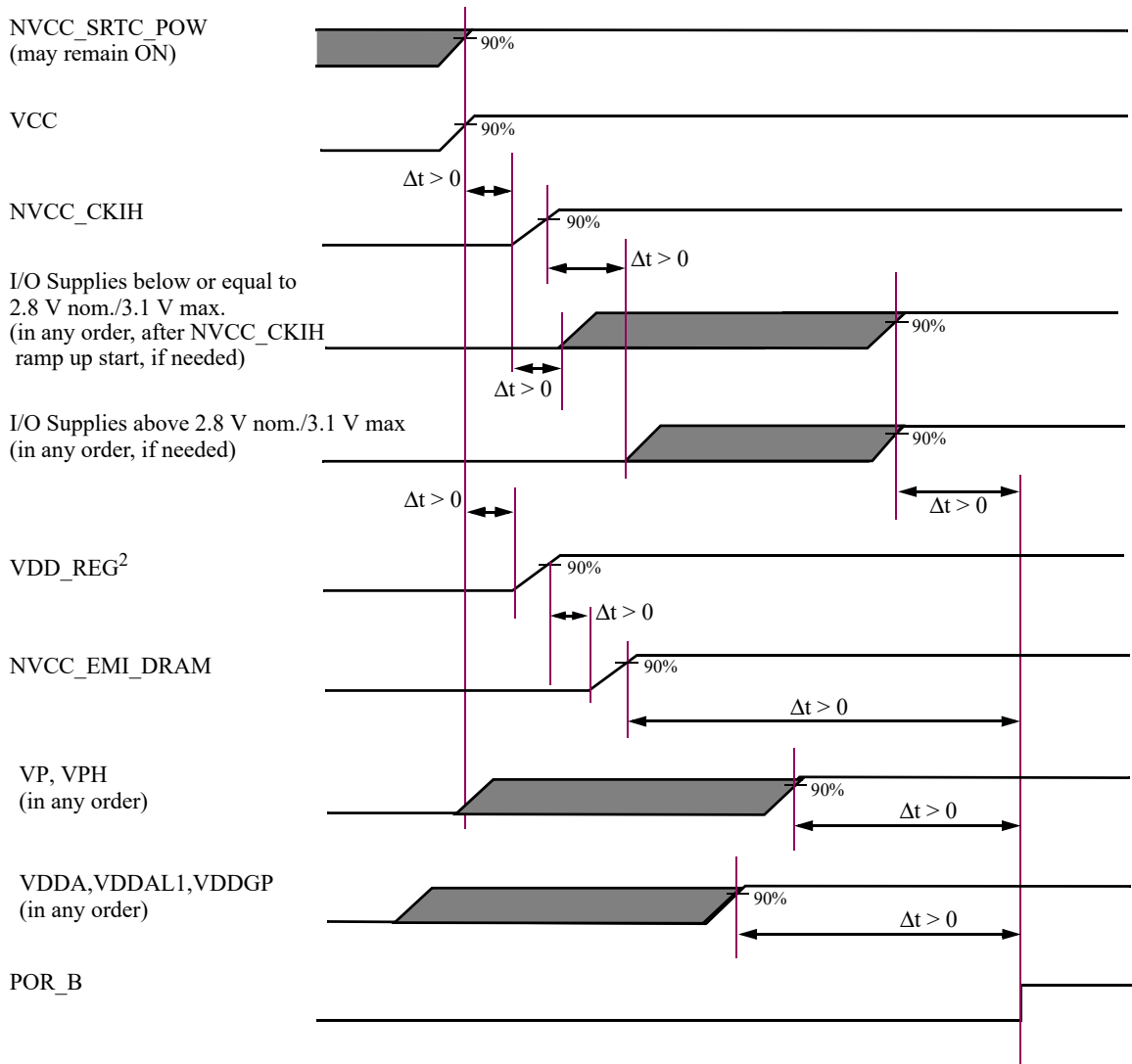

Figure 2. Power-Up Detailed Sequence

- ¹ If fuse writing is required, VDD_FUSE should be powered ON after NVCC_CKIH is stable.
- ² When SRTC is used, VDD_REG must power on after VDDA and VDDAL1.

NOTE

Need to ensure that there is no back voltage (leakage) from any supply on the board towards the 3.3 V supply (for example, from the parts that use both 1.8 V and the 3.3 V supply).

NOTE

For further details on power-up sequence, see the “Setting up Power Management” chapter of *i.MX53 System Development User’s Guide* (MX53UG).

4.2.2 Power-Down Sequence

Power-down sequence should follow one of the following two options:

- Option 1: Switch all supplies down simultaneously with further free discharge. A deviation of few microseconds of actual power-down of the different power rails is acceptable.
- Option 2: Switch down supplies, in any order, keeping the following rules:
 - NVCC_CKIH must be powered down at the same time or after the UHVIO I/O cell supplies (for full supply list, see [Table 7](#), Ultra High voltage I/O (UHVIO) supplies). A deviation of few microseconds of actual power-down of the different power rails is acceptable.
 - VDD_REG must be powered down at the same time or after NVCC_EMI_DRAM supply. A deviation of few microseconds of actual power-down of the different power rails is acceptable.
 - If all of the following conditions are met:
 - VDD_REG is powered down to 0V (Not Hi-Z)
 - VDD_DIG_PLL and VDD_ANA_PLL are provided externally,
 - VDD_REG is powered down before VDD_DIG_PLL and VDD_ANA_PLL
 Then the following rule should be kept: VDD_REG output impedance must be higher than 1 kW, when inactive.

4.2.3 Power Supplies Usage

- All I/O pins should not be externally driven while the I/O power supply for the pin (NVCC_XXX) is off. This can cause internal latch-up and malfunctions due to reverse current flows. For information about I/O power supply of each pin, see “Power Rail” columns in pin list tables of [Section 6, “Package Information and Contact Assignments.”](#)
- If not using SATA interface and the embedded thermal sensor, the VP and VPH should be grounded. In particular, keeping VPH turned OFF while the VP is powered ON is not recommended and might lead to excessive power consumption.
- When internal clock source is used for SATA temperature monitor the USB_PHY supplies and PLL need to be active because they are providing the clock.
- If not using the TVE module, the TVDAC_DHVDD and TVDAC_AHVDDRGB can be kept floating or tied to GND—the recommendation is to float. If only the GPIO pads in TVDAC_AHVDDRGB domain are in use, the supplies can be set to GPIO pad voltage range (1.65 V to 3.1 V).

4.3 I/O DC Parameters

This section includes the DC parameters of the following I/O types:

- General Purpose I/O (GPIO)
- Double Data Rate 3 I/O (DDR3) for DDR2/LVDDR2, LPDDR2 and DDR3 modes
- Low Voltage I/O (LVIO)
- Ultra High Voltage I/O (UHVIO)
- LVDS I/O

NOTE

The term ‘OVDD’ in this section refers to the associated supply rail of an input or output. The association is shown in [Table 114](#).

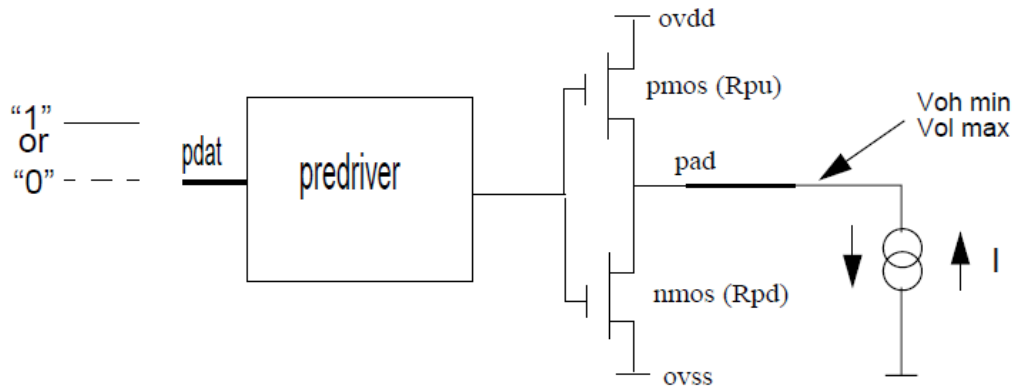

Figure 3. Circuit for Parameters Voh and Vol for I/O Cells

4.3.1 General Purpose I/O (GPIO) DC Parameters

The parameters in [Table 11](#) are guaranteed per the operating ranges in [Table 7](#), unless otherwise noted. [Table 11](#) shows DC parameters for GPIO pads, operating at two supply ranges:

- 1.1 V to 1.3 V
- 1.65 V to 3.1 V

Table 11. GPIO I/O DC Electrical Characteristics

Parameter	Symbol	Test Conditions	Min	Typ	Max	Unit
High-level output voltage ¹	Voh	I _{out} = -0.8 mA	OVDD - 0.15	—	—	V
Low-level output voltage ¹	Vol	I _{out} = 0.8 mA	—	—	0.15	V
High-Level DC input voltage ^{1, 2}	V _{IH}	—	0.7 × OVDD	—	OVDD	V
Low-Level DC input voltage ^{1, 2}	V _{IL}	—	0	—	0.3 × OVDD	V
Input Hysteresis	V _{HYS}	OVDD = 1.875 V OVDD = 2.775 V	0.25	0.34 0.45	—	V
Schmitt trigger VT+ ^{2, 3}	V _{T+}	—	0.5 × OVDD	—	—	V
Schmitt trigger VT- ^{2, 3}	V _{T-}	—	—	—	0.5 × OVDD	V
Input current (no pull-up/down)	I _{in}	V _{in} = OVDD or 0	—	—	10	μA
Input current (22 kΩ Pull-up)	I _{in}	V _{in} = 0 V V _{in} = OVDD	—	—	161 10	μA
Input current (47 kΩ Pull-up)	I _{in}	V _{in} = 0 V V _{in} = OVDD	—	—	76 10	μA
Input current (100 kΩ Pull-up)	I _{in}	V _{in} = 0 V V _{in} = OVDD	—	—	40 10	μA

Table 11. GPIO I/O DC Electrical Characteristics (continued)

Parameter	Symbol	Test Conditions	Min	Typ	Max	Unit
Input current (100 k Ω Pull-down)	I _{in}	V _{in} = 0 V V _{in} = OVDD	—	—	10 40	μ A
Keeper Circuit Resistance	—	—	—	130 ⁴	—	k Ω

¹ Overshoot and undershoot conditions (transitions above OVDD and below GND) on switching pads must be held below 0.6 V, and the duration of the overshoot/undershoot must not exceed 10% of the system clock cycle. Overshoot/undershoot must be controlled through printed circuit board layout, transmission line impedance matching, signal line termination, or other methods. Non-compliance to this specification may affect device reliability or cause permanent damage to the device.

² To maintain a valid level, the transition edge of the input must sustain a constant slew rate (monotonic) from the current DC level through to the target DC level, VIL or VIH. Monotonic input transition time is from 0.1 ns to 1 s.

³ Hysteresis of 250 mV is guaranteed over all operating conditions when hysteresis is enabled.

⁴ Use an off-chip pull resistor of less than 60 k Ω to override this keeper.

4.3.2 LPDDR2 I/O DC Parameters

The LPDDR2 I/O pads support DDR2/LVDDR2, LPDDR2, and DDR3 operational modes.

4.3.2.1 DDR2 Mode I/O DC Parameters

The DDR2 interface fully complies with JESD79-2E DDR2 JEDEC standard release April, 2008. The parameters in Table 12 are guaranteed per the operating ranges in Table 7, unless otherwise noted.

Table 12. DDR2 I/O DC Electrical Parameters¹

Parameters	Symbol	Test Conditions	Min	Typ	Max	Unit
High-level output voltage ²	V _{oh}	I _{oh} = -0.1 mA	0.9 x OVDD	—	—	V
Low-level output voltage	V _{ol}	I _{ol} = 0.1 mA	—	—	0.1 x OVDD	V
Input Reference Voltage	V _{ref}	—	0.49 x OVDD	0.5 x OVDD	0.51 x OVDD	
DC input High Voltage (data pins)	V _{ihd} (dc)	—	V _{ref} +0.125V	—	OVDD+0.3	V
DC input Low Voltage (data pins)	V _{ild} (dc)	—	-0.3	—	V _{ref} - 0.125V	V
DC Input voltage range of each differential input ³	V _{in} (dc)	—	-0.3	—	OVDD + 0.3	V
DC Differential input voltage required for switching ⁴	V _{id} (dc)	—	0.25	—	OVDD + 0.6	V
Termination Voltage	V _{tt}	V _{tt}	V _{ref} - 0.04	V _{ref}	V _{ref} + 0.04	V
Input current (no pull-up/down)	I _{in}	V _{in} = 0 V V _{in} = OVDD	— —	— —	1 1	μ A
Keeper Circuit Resistance	—	—	—	130 ⁵	—	k Ω

¹ Note that the JEDEC SSTL_18 specification (JESD8-15a) for a SSTL interface for class II operation supersedes any specification in this document.

² OVDD is the I/O power supply (1.7 V–1.9 V for DDR2)

- ³ $V_{in(dc)}$ specifies the allowable DC voltage exertion of each differential input.
- ⁴ $V_{id(dc)}$ specifies the input differential voltage $|V_{tr}-V_{cp}|$ required for switching, where V_{tr} is the “true” input level and V_{cp} is the “complementary” input level. The minimum value is equal to $V_{ih(dc)} - V_{il(dc)}$.
- ⁵ Use an off-chip pull resistor of less than 60 k Ω to override this keeper.

4.3.2.2 LPDDR2 Mode I/O DC Parameters

The LPDDR2 interface fully complies with JESD209-2B LPDDR2 JEDEC standard release June, 2009. The parameters in Table 13 are guaranteed per the operating ranges in Table 7, unless otherwise noted.

Table 13. LPDDR2 I/O DC Electrical Parameters¹

Parameters	Symbol	Test Conditions	Min	Typ	Max	Unit
High-level output voltage	V_{oh}	$I_{oh} = -0.1 \text{ mA}$	$0.9 \times OVDD$	—	—	V
Low-level output voltage	V_{ol}	$I_{ol} = 0.1 \text{ mA}$	—	—	$0.1 \times OVDD$	V
Input Reference Voltage	V_{ref}		$0.49 \times OVDD$	$0.5 \times OVDD$	$0.51 \times OVDD$	
DC input High Voltage	$V_{ih(dc)}$	—	$V_{ref}+0.13V$	—	OVDD	V
DC input Low Voltage	$V_{il(dc)}$	—	OVSS	—	$V_{ref} - 0.13V$	V
Differential Input Logic High	$V_{ih(diff)}$		0.26		See Note ²	
Differential Input Logic Low	$V_{il(diff)}$		See Note ²		-0.26	
Input current (no pull-up/down)	I_{in}	$V_{in} = 0 \text{ V}$ $V_{in} = OVDD$	— —	— —	1 1	μA
Pull-up/Pull-down impedance Mismatch			-15		+15	%
240 Ω unit calibration resolution					10	Ω
Keeper Circuit Resistance	—	—	—	140^3	—	k Ω

- ¹ Note that the JEDEC LPDDR2 specification (JESD209_2B) supersedes any specification in this document.
- ² The single-ended signals need to be within the respective limits ($V_{ih(dc)}$ max, $V_{il(dc)}$ min) for single-ended signals as well as the limitations for overshoot and undershoot.
- ³ Use an off-chip pull resistor of less than 60 k Ω to override this keeper.

4.3.2.3 DDR3 Mode I/O DC Parameters

The DDR3 interface fully complies with JESD79-3D DDR3 JEDEC standard release April, 2008. The parameters in Table 14 are guaranteed per the operating ranges in Table 7, unless otherwise noted.

Table 14. DDR3 I/O DC Electrical Parameters

Parameters	Symbol	Test Conditions	Min	Typ	Max	Unit
High-level output voltage	V_{oh}	$I_{oh} = -0.1 \text{ mA}$	$0.8 \times OVDD^1$	—	—	V
Low-level output voltage	V_{ol}	$I_{ol} = 0.1 \text{ mA}$	—	—	$0.2 \times OVDD$	V
DC input Logic High	$V_{IH(dc)}$	—	$V_{ref}^2+0.1$	—	OVDD	V
DC input Logic Low	$V_{IL(dc)}$	—	OVSS	—	$V_{ref}-0.1$	V
Differential input Logic High	$V_{IH(diff)}$	—	0.2	—	See Note ³	V

Electrical Characteristics

Table 14. DDR3 I/O DC Electrical Parameters (continued)

Differential input Logic Low	VIL(diff)	—	See Note ³	—	-0.2	V
Over/undershoot peak	Vpeak	—	—	—	0.4	V
Over/undershoot area (above OVDD or below OVSS)	Varea	—	—	—	0.67	V-ns
Termination Voltage	Vtt	Vtt tracking OVDD/2	0.49 x OVDD	Vref	0.51 x OVDD	V
Input current (no pull-up/down)	Iin	VI = 0 V VI=OVDD	— —	— —	1 1	μA
Pull-up/Pull-down impedance mismatch	—	Minimum impedance configuration	—	—	3	Ω
240 Ω unit calibration resolution	—	—	—	—	10	Ω
Keeper Circuit Resistance	—	—	—	130 ⁴	—	kΩ

¹ OVDD— I/O power supply (1.425 V–1.575 V for DDR3)

² Vref— DDR3 external reference voltage

³ The single-ended signals need to be within the respective limits (Vih(dc) max, Vil(dc) min) for single-ended signals as well as the limitations for overshoot and undershoot.

⁴ Use an off-chip pull resistor of less than 60 kΩ to override this keeper.

4.3.3 Low Voltage I/O (LVIO) DC Parameters

The parameters in [Table 15](#) are guaranteed per the operating ranges in [Table 7](#), unless otherwise noted. The LVIO pads operate only as inputs.

Table 15. LVIO DC Electrical Characteristics

DC Electrical Characteristics	Symbol	Test Conditions	Min	Typ	Max	Unit
High-Level DC input voltage ^{1, 2}	Vih	Ioh = -0.8 mA	0.7 × OVDD	—	OVDD	V
Low-Level DC input voltage ^{1, 2}	Vil	Iol = 0.8 mA	0	—	0.3 × OVDD	V
Input Hysteresis	Vhys	OVDD = 1.875 V OVDD = 2.775 V	0.35	0.62 1.27	—	V
Schmitt trigger VT+ ^{2, 3}	VT+	—	0.5 × OVDD	—	—	V
Schmitt trigger VT- ^{2, 3}	VT-	—	—	—	0.5 × OVDD	V
Input current (no pull-up/down)	Iin	Vin = OVDD or 0 V	—	—	1	μA
Input current (22 kΩ Pull-up)	Iin	Vin = 0 V Vin = OVDD	—	—	161 1	μA
Input current (47 kΩ Pull-up)	Iin	Vin = 0 V Vin = OVDD	—	—	76 1	μA
Input current (100 kΩ Pull-up)	Iin	Vin = 0 V Vin = OVDD	—	—	36 1	μA
Input current (100 kΩ Pull-down)	Iin	Vin = 0 V Vin = OVDD	—	—	1 36	μA
Keeper Circuit Resistance	—	—	—	130 ⁴	—	kΩ

- ¹ Overshoot and undershoot conditions (transitions above OVDD and below GND) on switching pads must be held below 0.6 V, and the duration of the overshoot/undershoot must not exceed 10% of the system clock cycle. Overshoot/undershoot must be controlled through printed circuit board layout, transmission line impedance matching, signal line termination, or other methods. Non-compliance to this specification may affect device reliability or cause permanent damage to the device.
- ² To maintain a valid level, the transition edge of the input must sustain a constant slew rate (monotonic) from the current DC level through to the target DC level, VIL or VIH. Monotonic input transition time is from 0.1 ns to 1 s. VIL and VIH do not apply when hysteresis is enabled.
- ³ Hysteresis of 350 mV is guaranteed over all operating conditions when hysteresis is enabled.
- ⁴ Use an off-chip pull resistor of less than 60 kΩ to override this keeper.

4.3.4 Ultra-High Voltage I/O (UHVIO) DC Parameters

The parameters in Table 16 are guaranteed per the operating ranges in Table 7, unless otherwise noted.

Table 16. UHVIO DC Electrical Characteristics

DC Electrical Characteristics	Symbol	Test Conditions	Min	Typ	Max	Unit
High-level output voltage ¹	Voh	I _{out} = -0.8 mA	OVDD-0.15	—	—	V
Low-level output voltage ¹	Vol	I _{out} = 0.8 mA	—	—	0.15	V
High-Level DC input voltage ^{1, 2}	VIH	—	0.7 × OVDD	—	OVDD	V
Low-Level DC input voltage ^{1, 2}	VIL	—	0	—	0.3 × OVDD	V
Input Hysteresis	VHYS	low voltage mode high voltage mode	0.38 0.95	—	0.43 1.33	V
Schmitt trigger VT+ ^{2, 3}	VT+	—	0.5 × OVDD	—	—	V
Schmitt trigger VT- ^{2, 3}	VT-	—	—	—	0.5 × OVDD	V
Input current (no pull-up/down)	I _{in}	V _{in} = OVDD or 0 V	—	—	1	μA
Input current (22 kΩ Pull-up)	I _{in}	V _{in} = 0 V _{in} = OVDD	—	—	202 1	μA
Input current (75 kΩ Pull-up)	I _{in}	V _{in} = 0 V _{in} = OVDD	—	—	61 1	μA
Input current (100 kΩ Pull-up)	I _{in}	V _{in} = 0 V _{in} = OVDD	—	—	47 1	μA
Input current (360 kΩ Pull-down)	I _{in}	V _{in} = 0 V _{in} = OVDD	—	—	1 5.7	μA
Keeper Circuit Resistance	—	—	—	130 ⁴	—	kΩ

- ¹ Overshoot and undershoot conditions (transitions above OVDD and below GND) on switching pads must be held below 0.6 V, and the duration of the overshoot/undershoot must not exceed 10% of the system clock cycle. Overshoot/undershoot must be controlled through printed circuit board layout, transmission line impedance matching, signal line termination, or other methods. Non-compliance to this specification may affect device reliability or cause permanent damage to the device.
- ² To maintain a valid level, the transitioning edge of the input must sustain a constant slew rate (monotonic) from the current DC level to the target DC level, VIL or VIH. Monotonic input transition time is from 0.1 ns to 1 s. VIL and VIH do not apply when hysteresis is enabled.
- ³ Hysteresis of 250 mV is guaranteed over all operating conditions when hysteresis is enabled.
- ⁴ Use an off-chip pull resistor of less than 60 kΩ to override this keeper.

4.3.5 LVDS I/O DC Parameters

The LVDS interface complies with TIA/EIA 644-A standard. See TIA/EIA STANDARD 644-A, “Electrical Characteristics of Low Voltage Differential Signaling (LVDS) Interface Circuits” for details.

Table 17 shows the Low Voltage Differential Signaling (LVDS) DC electrical characteristics. The parameters in Table 17 are guaranteed per the operating ranges in Table 7, unless otherwise noted.

Table 17. LVDS DC Electrical Characteristics

DC Electrical Characteristics	Symbol	Test Conditions	Min	Typ	Max	Unit
Output Differential Voltage	V_{OD}	Rload = 100Ω between padP and padN	250	350	450	mV
Output High Voltage	V_{OH}		1.25	1.375	1.6	V
Output Low Voltage	V_{OL}		0.9	1.025	1.25	
Offset Voltage	V_{OS}		1.125	1.2	1.375	

4.4 Output Buffer Impedance Characteristics

This section defines the I/O Impedance parameters of the i.MX53 processor for the following I/O types:

- General Purpose I/O (GPIO)
- Double Data Rate 3 I/O (DDR3) for DDR2/LVDDR2, LPDDR2, and DDR3 modes
- Ultra High Voltage I/O (UHVIO)
- LVDS I/O

NOTE

Output driver impedance is measured with “long” transmission line of impedance Z_{tl} attached to I/O pad and incident wave launched into transmission line. R_{pu}/R_{pd} and Z_{tl} form a voltage divider that defines specific voltage of incident wave relative to OVDD. Output driver impedance is calculated from this voltage divider (see Figure 4).

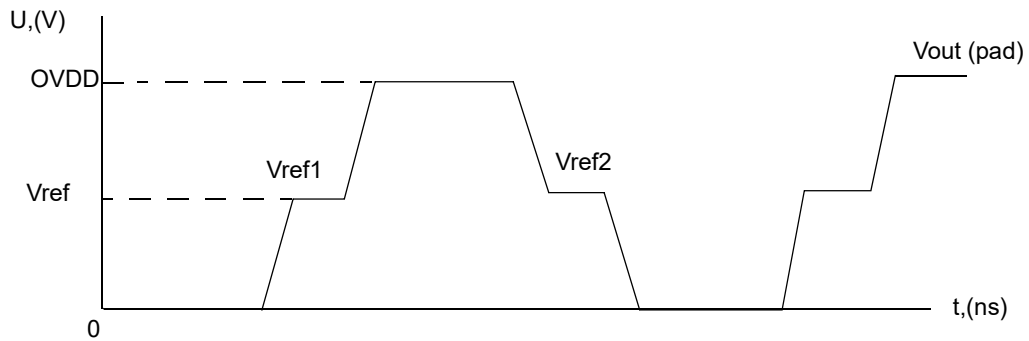
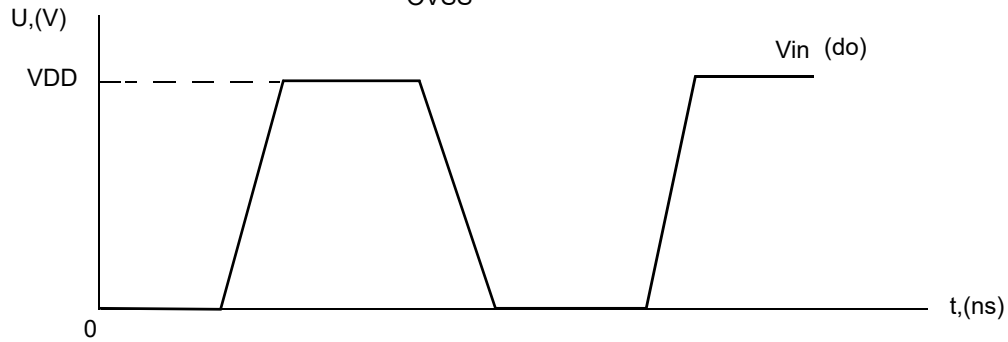
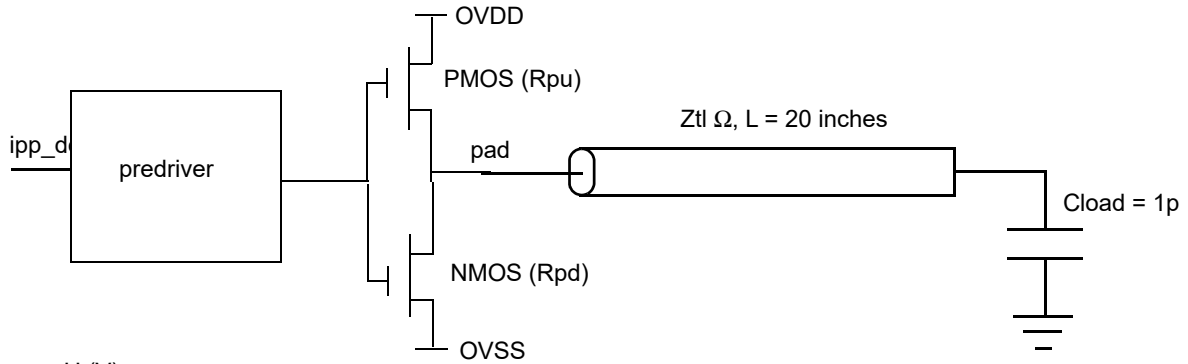

$$R_{pu} = \frac{V_{ovdd} - V_{ref1}}{V_{ref1}} \times Z_{tl}$$

$$R_{pd} = \frac{V_{ref2}}{V_{ovdd} - V_{ref2}} \times Z_{tl}$$

Figure 4. Impedance Matching Load for Measurement

4.4.1 GPIO Output Buffer Impedance

Table 18 shows the GPIO output buffer impedance.

Table 18. GPIO Output Buffer Impedance

Parameter	Symbol	Test Conditions	Min	Typ		Max	Unit
				OVDD 2.775 V	OVDD 1.875 V		
Output Driver Impedance	Rpu	Low Drive Strength, Ztl = 150 Ω	80	104	150	250	Ω
		Medium Drive Strength, Ztl = 75 Ω	40	52	75	125	
		High Drive Strength, Ztl = 50 Ω	27	35	51	83	
		Max Drive Strength, Ztl = 37.5 Ω	20	26	38	62	
Output Driver Impedance	Rpd	Low Drive Strength, Ztl = 150 Ω	64	88	134	243	Ω
		Medium Drive Strength, Ztl = 75 Ω	32	44	66	122	
		High Drive Strength, Ztl = 50 Ω	21	30	44	81	
		Max Drive Strength, Ztl = 37.5 Ω	16	22	34	61	

4.4.2 DDR Output Driver Average Impedance

The DDR2/LVDDR2 interface fully complies with JESD79-2E DDR2 JEDEC standard release April, 2008. The DDR3 interface fully complies with JESD79-3D DDR3 JEDEC standard release April, 2008.

Table 19 shows DDR output driver average impedance of the i.MX53 processor.

Table 19. DDR Output Driver Average Impedance¹

Parameter	Symbol	Test Conditions	Drive strength (DSE)								Unit
			000	001	010	011	100	101	110	111	
Output Driver Impedance	Rdrv ²	LPDDR1/DDR2 mode NVCC_DRAM = 1.8 V DDR_SEL = 00 Calibration resistance = 300 Ω ³	Hi-Z	300	150	100	75	60	50	43	Ω
		DDR2 mode NVCC_DRAM = 1.8 V DDR_SEL = 01 Calibration resistance = 180 Ω ³	Hi-Z	180	90	60	45	36	30	26	
		DDR2 mode NVCC_DRAM = 1.8 V DDR_SEL = 10 Calibration resistance = 200 Ω ³	Hi-Z	200	100	66	50	40	33	28	
		DDR2 mode NVCC_DRAM = 1.8 V DDR_SEL = 11 Calibration resistance = 140 Ω ³	Hi-Z	140	70	46	35	28	23	20	
		LPDDR2 mode NVCC_DRAM = 1.2 V DDR_SEL = 01 ⁴ Calibration resistance = 160 Ω ³	Hi-Z	160	80	53	40	32	27	23	
		LPDDR2 mode NVCC_DRAM = 1.2 V DDR_SEL = 10 Calibration resistance = 240 Ω ³	Hi-Z	240	120	80	60	48	40	34	
		LPDDR2 mode NVCC_DRAM = 1.2 V DDR_SEL = 11 ⁴ Calibration resistance = 160 Ω ³	Hi-Z	160	80	53	40	32	27	23	
		DDR3 mode NVCC_DRAM = 1.5 V DDR_SEL = 00 Calibration resistance = 200 Ω ³	Hi-Z	240	120	80	60	48	48	34	

¹ Output driver impedance is controlled across PVTs (process, voltages, and temperatures) using calibration procedure and pu_cal, pd_cal input pins.

² Output driver impedance deviation (calibration accuracy) is ±5% (max/min impedance) across PVTs.

³ Calibration is done against external reference resistor. Value of the resistor should be varied depending on DDR mode and DDR_SEL setting.

⁴ If DDR_SEL = '01' or DDR_SEL = '11' are selected with NVCC_DRAM = 1.2 V for LPDDR2 operation, the external reference resistor value must be 160 Ω for a correct ZQ calibration. In any case, reference resistors attached to the DDR memory devices should be kept to 240 Ω per the JEDEC standard.

4.4.3 UHVIO Output Buffer Impedance

Table 20 shows the UHVIO output buffer impedance.

Table 20. UHVIO Output Buffer Impedance

Parameter	Symbol	Test Conditions	Min		Typ		Max		Unit
			OVDD 1.95 V	OVDD 3.0 V	OVDD 1.875 V	OVDD 3.3 V	OVDD 1.65 V	OVDD 3.6 V	
Output Driver Impedance	Rpu	Low Drive Strength, Ztl = 150 Ω	98	114	124	135	198	206	Ω
		Medium Drive Strength, Ztl = 75 Ω	49	57	62	67	99	103	
		High Drive Strength, Ztl = 50 Ω	32	38	41	45	66	69	
Output Driver Impedance	Rpd	Low Drive Strength, Ztl = 150 Ω	97	118	126	154	179	217	Ω
		Medium Drive Strength, Ztl = 75 Ω	49	59	63	77	89	109	
		High Drive Strength, Ztl = 50 Ω	32	40	42	51	60	72	

4.4.4 LVDS I/O Output Buffer Impedance

The LVDS interface complies with TIA/EIA 644-A standard. See, TIA/EIA STANDARD 644-A, “Electrical Characteristics of Low Voltage Differential Signaling (LVDS) Interface Circuits” for details.

4.5 I/O AC Parameters

This section includes the AC parameters of the following I/O types:

- General Purpose I/O (GPIO)
- Double Data Rate 3 I/O (DDR3) for DDR2/LVDDR2, LPDDR2 and DDR3 modes
- Low Voltage I/O (LVIO)
- Ultra High Voltage I/O (UHVIO)
- LVDS I/O

The load circuit and output transition time waveforms are shown in Figure 5 and Figure 6.

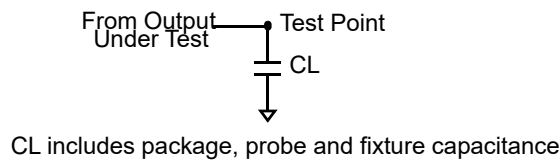

Figure 5. Load Circuit for Output

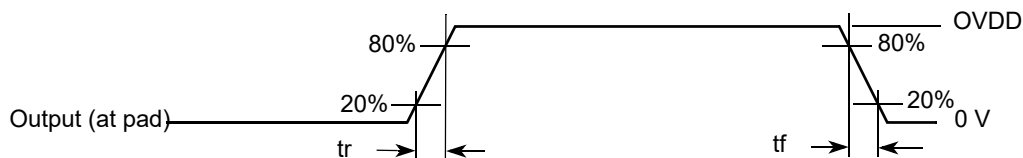

Figure 6. Output Transition Time Waveform

4.5.1 GPIO I/O AC Electrical Characteristics

AC electrical characteristics for GPIO I/O in slow and fast modes are presented in the [Table 21](#) and [Table 22](#), respectively. Note that the fast or slow I/O behavior is determined by the appropriate control bit in the IOMUXC control registers.

Table 21. GPIO I/O AC Parameters Slow Mode

Parameter	Symbol	Test Condition	Min	Typ	Max	Unit
Output Pad Transition Times (Max Drive)	tr, tf	15 pF 35 pF	—	—	1.91/1.52 3.07/2.65	ns
Output Pad Transition Times (High Drive)	tr, tf	15 pF 35 pF	—	—	2.22/1.81 3.81/3.42	ns
Output Pad Transition Times (Medium Drive)	tr, tf	15 pF 35 pF	—	—	2.88/2.42 5.43/5.02	ns
Output Pad Transition Times (Low Drive)	tr, tf	15 pF 35 pF	—	—	4.94/4.50 10.55/9.70	ns
Output Pad Slew Rate (Max Drive) ¹	tps	15 pF 35 pF	0.5/0.65 0.32/0.37	—	—	V/ns
Output Pad Slew Rate (High Drive) ¹	tps	15 pF 35 pF	0.43/0.54 0.26/0.41	—	—	
Output Pad Slew Rate (Medium Drive) ¹	tps	15 pF 35 pF	0.34/0.41 0.18/0.2	—	—	
Output Pad Slew Rate (Low Drive) ¹	tps	15 pF 35 pF	0.20/0.22 0.09/0.1	—	—	
Output Pad di/dt (Max Drive)	tdit	—	—	—	30	mA/ns
Output Pad di/dt (High Drive)	tdit	—	—	—	23	
Output Pad di/dt (Medium drive)	tdit	—	—	—	15	
Output Pad di/dt (Low drive)	tdit	—	—	—	7	
Input Transition Times ²	trm	—	—	—	25	ns

¹ tps is measured between VIL to VIH for rising edge and between VIH to VIL for falling edge.

² Hysteresis mode is recommended for inputs with transition times greater than 25 ns.

Table 22. GPIO I/O AC Parameters Fast Mode

Parameter	Symbol	Test Condition	Min	Typ	Max	Unit
Output Pad Transition Times (Max Drive)	tr, tf	15 pF 35 pF	—	—	1.45/1.24 2.76/2.54	ns
Output Pad Transition Times (High Drive)	tr, tf	15 pF 35 pF	—	—	1.81/1.59 3.57/3.33	ns
Output Pad Transition Times (Medium Drive)	tr, tf	15 pF 35 pF	—	—	2.54/2.29 5.25/5.01	ns

Electrical Characteristics

Table 22. GPIO I/O AC Parameters Fast Mode (continued)

Parameter	Symbol	Test Condition	Min	Typ	Max	Unit
Output Pad Transition Times (Low Drive)	tr, tf	15 pF 35 pF	—	—	4.82/4.5 10.54/9.95	ns
Output Pad Slew Rate (Max Drive) ¹	tps	15 pF 35 pF	0.69/0.78 0.36/0.39	—	—	V/ns
Output Pad Slew Rate (High Drive) ¹	tps	15 pF 35 pF	0.55/0.62 0.28/0.30	—	—	V/ns
Output Pad Slew Rate (Medium Drive) ¹	tps	15 pF 35 pF	0.39/0.44 0.19/0.20	—	—	V/ns
Output Pad Slew Rate (Low Drive) ¹	tps	15 pF 35 pF	0.21/0.22 0.09/0.1	—	—	V/ns
Output Pad di/dt (Max Drive)	tdit	—	—	—	70	mA/ns
Output Pad di/dt (High Drive)	tdit	—	—	—	53	mA/ns
Output Pad di/dt (Medium drive)	tdit	—	—	—	35	mA/ns
Output Pad di/dt (Low drive)	tdit	—	—	—	18	mA/ns
Input Transition Times ²	trm	—	—	—	25	ns

¹ tps is measured between VIL to VIH for rising edge and between VIH to VIL for falling edge.

² Hysteresis mode is recommended for inputs with transition time greater than 25 ns.

4.5.2 LPDDR2 I/O AC Electrical Characteristics

The DDR2/LVDDR2 interface mode fully complies with JESD79-2E DDR2 JEDEC standard release April, 2008. The DDR3 interface mode fully complies with JESD79-3D DDR3 JEDEC standard release April, 2008.

Table 23 shows the AC parameters for LPDDR2 I/O operating in DDR2 mode.

Table 23. LPDDR2 I/O DDR2 mode AC Characteristics¹

Parameter	Symbol	Test Condition	Min	Typ	Max	Unit
AC input logic high	Vih(ac)	—	Vref+0.25	—	—	V
AC input logic low	Vil(ac)	—	—	—	Vref-0.25	V
AC differential input voltage ²	Vid(ac)	—	0.5	—	OVDD	V
Input AC differential cross point voltage ³	Vix(ac)	—	Vref - 0.175	—	Vref + 0.175	V
Output AC differential cross point voltage ⁴	Vox(ac)	—	Vref - 0.125	—	Vref + 0.125	V
Single output slew rate	tsr	At 25 W to Vref	0.4	—	2	V/ns
Skew between pad rise/fall asymmetry + skew caused by SSN	t _{SKD}	clk = 266 MHz clk = 400 MHz	—	—	0.2 0.1	ns

¹ Note that the JEDEC SSTL_18 specification (JESD8-15a) for class II operation supersedes any specification in this document.

- ² Vid(ac) specifies the input differential voltage $|V_{tr} - V_{cp}|$ required for switching, where V_{tr} is the “true” input signal and V_{cp} is the “complementary” input signal. The Minimum value is equal to $V_{ih}(ac) - V_{il}(ac)$.
- ³ The typical value of $V_{ix}(ac)$ is expected to be about $0.5 \times OVDD$. and $V_{ix}(ac)$ is expected to track variation of OVDD. $V_{ix}(ac)$ indicates the voltage at which differential input signal must cross.
- ⁴ The typical value of $V_{ox}(ac)$ is expected to be about $0.5 \times OVDD$ and $V_{ox}(ac)$ is expected to track variation in OVDD. $V_{ox}(ac)$ indicates the voltage at which differential output signal must cross.

Table 24 shows the AC parameters for LPDDR2 I/O operating in LPDDR2 mode.

Table 24. LPDDR2 I/O LPDDR2 mode AC Characteristics¹

Parameter	Symbol	Test Condition	Min	Typ	Max	Unit
AC input logic high	$V_{ih}(ac)$	—	$V_{ref} + 0.22$	—	OVDD	V
AC input logic low	$V_{il}(ac)$	—	0	—	$V_{ref} - 0.22$	V
AC differential input high voltage ²	$V_{idh}(ac)$	—	0.44	—	—	V
AC differential input low voltage	$V_{idl}(ac)$	—	—	—	0.44	V
Input AC differential cross point voltage ³	$V_{ix}(ac)$	Relative to $OVDD/2$	-0.12	—	0.12	V
Over/undershoot peak	V_{peak}	—	—	—	0.35	V
Over/undershoot area (above OVDD or below OVSS)	V_{area}	266 MHz	—	—	0.6	V-ns
Single output slew rate	tsr	50 Ω to V_{ref} . 5pF load. Drive impedance= 40 $\Omega \pm 30\%$	1.5	—	3.5	V/ns
		50 Ω to V_{ref} . 5 pF load. Drive impedance= 60 $\Omega \pm 30\%$	1	—	2.5	
Skew between pad rise/fall asymmetry + skew caused by SSN	t_{SKD}	clk = 266 MHz clk = 400 MHz	—	—	0.2 0.1	ns

- ¹ Note that the JEDEC LPDDR2 specification (JESD209_2B) supersedes any specification in this document.
- ² Vid(ac) specifies the input differential voltage $|V_{tr} - V_{cp}|$ required for switching, where V_{tr} is the “true” input signal and V_{cp} is the “complementary” input signal. The Minimum value is equal to $V_{ih}(ac) - V_{il}(ac)$.
- ³ The typical value of $V_{ix}(ac)$ is expected to be about $0.5 \times OVDD$. and $V_{ix}(ac)$ is expected to track variation of OVDD. $V_{ix}(ac)$ indicates the voltage at which differential input signal must cross.

Table 25 shows the AC parameters for LPDDR2 I/O operating in DDR3 mode.

Table 25. LPDDR2 I/O DDR3 mode AC Characteristics¹

Parameter	Symbol	Test Condition	Min	Typ	Max	Unit
AC input logic high	$V_{ih}(ac)$	—	$V_{ref} + 0.175$	—	OVDD	V
AC input logic low	$V_{il}(ac)$	—	0	—	$V_{ref} - 0.175$	V
AC differential input voltage ²	$V_{id}(ac)$	—	0.35	—	—	V
Input AC differential cross point voltage ³	$V_{ix}(ac)$	—	$V_{ref} - 0.15$	—	$V_{ref} + 0.15$	V
Output AC differential cross point voltage ⁴	$V_{ox}(ac)$	—	$V_{ref} - 0.15$	—	$V_{ref} + 0.15$	V

Electrical Characteristics

Table 25. LPDDR2 I/O DDR3 mode AC Characteristics¹ (continued)

Parameter	Symbol	Test Condition	Min	Typ	Max	Unit
Single output slew rate	tsr	At 25 Ω to Vref	2.5	—	5	V/ns
Skew between pad rise/fall asymmetry + skew caused by SSN	t _{SKD}	clk = 266 MHz clk = 400 MHz	—	—	0.2 0.1	ns

¹ Note that the JEDEC JESD79_3C specification supersedes any specification in this document.

² Vid(ac) specifies the input differential voltage |Vtr-Vcp| required for switching, where Vtr is the “true” input signal and Vcp is the “complementary” input signal. The Minimum value is equal to Vih(ac) - Vil(ac).

³ The typical value of Vix(ac) is expected to be about 0.5 x OVDD. and Vix(ac) is expected to track variation of OVDD. Vix(ac) indicates the voltage at which differential input signal must cross.

⁴ The typical value of Vox(ac) is expected to be about 0.5 x OVDD and Vox(ac) is expected to track variation in OVDD. Vox(ac) indicates the voltage at which differential output signal must cross.

4.5.3 LVIO I/O AC Electrical Characteristics

AC electrical characteristics for LVIO I/O in slow and fast modes are presented in the [Table 26](#) and [Table 27](#), respectively. Note that the fast or slow I/O behavior is determined by the appropriate control bit in the IOMUXC control registers.

Table 26. LVIO I/O AC Parameters in Slow Mode

Parameter	Symbol	Test Condition	Min	Typ	Max	Unit
Input Transition Times ¹	trm	—	—	—	25	ns

¹ Hysteresis mode is recommended for inputs with transition times greater than 25 ns.

4.5.4 UHVIO I/O AC Electrical Characteristics

Table 27. LVIO I/O AC Parameters in Fast Mode

Parameter	Symbol	Test Condition	Min	Typ	Max	Unit
Input Transition Times ¹	trm	—	—	—	25	ns

¹ Hysteresis mode is recommended for inputs with transition time greater than 25 ns.

Table 28 shows the AC parameters for UHVIO I/O operating in low output voltage mode. Table 29 shows the AC parameters for UHVIO I/O operating in high output voltage mode.

Table 28. AC Electrical Characteristics of UHVIO Pad (Low Output Voltage Mode)

Parameter	Symbol	Test Condition	Min	Typ	Max	Unit
Output Pad Transition Times (High Drive)	tr, tf	15 pF 35 pF	—	—	1.59/1.69 3.05/3.30	ns
Output Pad Transition Times (Medium Drive)	tr, tf	15 pF 35 pF	—	—	2.16/2.35 4.45/4.84	
Output Pad Transition Times (Low Drive)	tr, tf	15 pF 35 pF	—	—	4.06/4.42 8.79/9.55	
Output Pad Slew Rate (High Drive) ¹	tps	15 pF 35 pF	0.63/0.59 0.33/0.30	—	—	V/ns
Output Pad Slew Rate (Medium Drive) ¹	tps	15 pF 35 pF	0.46/0.42 0.22/0.21	—	—	
Output Pad Slew Rate (Low Drive) ¹	tps	15 pF 35 pF	0.25/0.23 0.11/0.11	—	—	
Output Pad di/dt (High Drive)	tdit	—	—	—	43.6	mA/ns
Output Pad di/dt (Medium drive)	tdit	—	—	—	32.3	
Output Pad di/dt (Low drive)	tdit	—	—	—	18.24	
Input Transition Times ²	trm	—	—	—	25	ns

¹ tps is measured between VIL to VIH for rising edge and between VIH to VIL for falling edge.

² Hysteresis mode is recommended for inputs with transition times greater than 25 ns.

Table 29. AC Electrical Characteristics of UHVIO Pad (High Output Voltage Mode)

Parameter	Symbol	Test Condition	Min	Typ	Max	Unit
Output Pad Transition Times (High Drive)	tr, tf	15 pF 35 pF	—	—	1.72/1.92 3.46/3.70	ns
Output Pad Transition Times (Medium Drive)	tr, tf	15 pF 35 pF	—	—	2.38/2.56 5.07/5.25	
Output Pad Transition Times (Low Drive)	tr, tf	15 pF 35 pF	—	—	4.55/4.58 10.04/9.94	

Electrical Characteristics

Table 29. AC Electrical Characteristics of UHVIO Pad (High Output Voltage Mode) (continued)

Parameter	Symbol	Test Condition	Min	Typ	Max	Unit
Output Pad Slew Rate (High Drive) ¹	tps	15 pF 35 pF	1.05/0.94 0.52/0.49	—	—	V/ns
Output Pad Slew Rate (Medium Drive) ¹	tps	15 pF 35 pF	0.76/0.71 0.36/0.34	—	—	
Output Pad Slew Rate (Low Drive) ¹	tps	15 pF 35 pF	0.40/0.93 0.18/0.18	—	—	
Output Pad di/dt (High Drive)	tdit	—	—	—	82.8	mA/ns
Output Pad di/dt (Medium drive)	tdit	—	—	—	65.6	
Output Pad di/dt (Low drive)	tdit	—	—	—	43.1	
Input Transition Times ²	trm	—	—	—	25	ns

¹ tps is measured between VIL to VIH for rising edge and between VIH to VIL for falling edge.

² Hysteresis mode is recommended for inputs with transition times greater than 25 ns.

4.5.5 LVDS I/O AC Electrical Characteristics

The differential output transition time waveform is shown in [Figure 7](#).

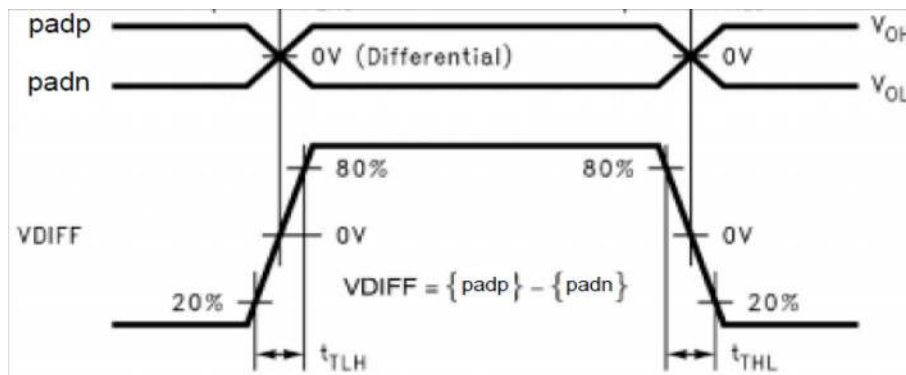

Figure 7. Differential LVDS Driver Transition Time Waveform

[Table 30](#) shows the AC parameters for LVDS I/O.

Table 30. AC Electrical Characteristics of LVDS Pad

Parameter	Symbol	Test Condition	Min	Typ	Max	Unit
Transition Low to High Time ¹	t_{TLH}	Rload = 100 Ω , Clod = 2 pF	0.26	—	0.5	ns
Transition High to Low Time ¹	t_{THL}		0.26	—	0.5	
Operating Frequency	f	—	—	300	—	MHz
Offset voltage imbalance	Vos	—	—	—	150	mV

¹ Measurement levels are 20–80% from output voltage.

4.6 System Modules Timing

This section contains the timing and electrical parameters for the modules in the i.MX53 processor.

4.6.1 Reset Timings Parameters

Figure 8 shows the reset timing and Table 31 lists the timing parameters.

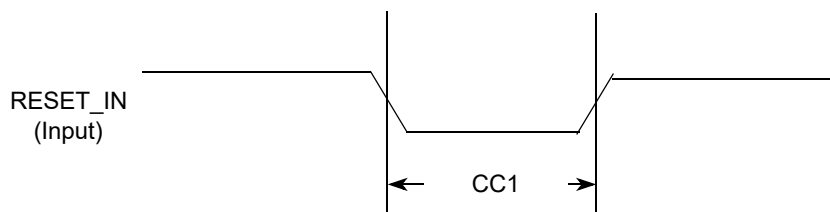

Figure 8. Reset Timing Diagram

Table 31. Reset Timing Parameters

ID	Parameter	Min	Max	Unit
CC1	Duration of RESET_IN to be qualified as valid (input slope = 5 ns)	50	—	ns

4.6.2 WDOG Reset Timing Parameters

Figure 9 shows the WDOG reset timing and Table 32 lists the timing parameters.

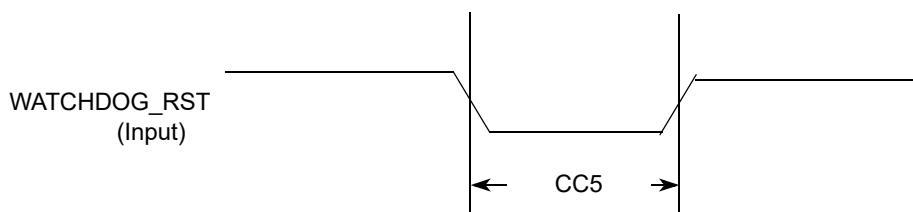

Figure 9. WATCHDOG_RST Timing Diagram

Table 32. WATCHDOG_RST Timing Parameters

ID	Parameter	Min	Max	Unit
CC5	Duration of WATCHDOG_RESET Assertion	1	—	T_{CKIL}

NOTE

CKIL is approximately 32 kHz. T_{CKIL} is one period or approximately 30 μ s.

4.6.3 Clock Amplifier Parameters (CKIH1, CKIH2)

The input to Clock Amplifier (CAMP) is internally ac-coupled allowing direct interface to a square wave or sinusoidal frequency source. No external series capacitors are required.

Electrical Characteristics

Table 33 shows the electrical parameters of CAMP.

Table 33. CAMP Electrical Parameters (CKIH1, CKIH2)

Parameter	Min	Typ	Max	Unit
Input frequency	8.0	—	40.0	MHz
VIL (for square wave input)	0	—	0.3	V
VIH (for square wave input) ¹	NVCC_CKIH - 0.25	—	NVCC_CKIH	V
Sinusoidal input amplitude	0.4	—	VDD	Vp-p
Output duty cycle	45	50	55	%

¹ NVCC_CKIH is the supply voltage of CAMP.

4.6.4 DPLL Electrical Parameters

Table 34 shows the electrical parameters of digital phase-locked loop (DPLL).

Table 34. DPLL Electrical Parameters

Parameter	Test Conditions/Remarks	Min	Typ	Max	Unit
Reference clock frequency range ¹	—	10	—	100	MHz
Reference clock frequency range after pre-divider	—	10	—	40	MHz
Output clock frequency range (dpdck_2)	—	300	—	1025	MHz
Pre-division factor ²	—	1	—	16	—
Multiplication factor integer part	—	5	—	15	—
Multiplication factor numerator ³	Should be less than denominator	-67108862	—	67108862	—
Multiplication factor denominator ²	—	1	—	67108863	—
Output Duty Cycle	—	48.5	50	51.5	%
Frequency lock time ⁴ (FOL mode or non-integer MF)	—	—	—	398	T _{dpdref}
Phase lock time	—	—	—	100	μs
Frequency jitter ⁵ (peak value)	—	—	0.02	0.04	T _{dck}
Phase jitter (peak value)	FPL mode, integer and fractional MF	—	2.0	3.5	ns
Power dissipation	f _{dck} = 300 MHz at avdd = 1.8 V, dvdd = 1.2 V f _{dck} = 650 MHz at avdd = 1.8 V, dvdd = 1.2 V	—	—	0.65 (avdd) 0.92 (dvdd) 1.98 (avdd) 1.8 (dvdd)	mW

¹ Device input range cannot exceed the electrical specifications of the CAMP, see Table 33.

² The values specified here are internal to DPLL. Inside the DPLL, a “1” is added to the value specified by the user. Therefore, the user has to enter a value “1” less than the desired value at the inputs of DPLL for PDF and MFD.

³ The maximum total multiplication factor (MFI + MFN/MFD) allowed is 15. Therefore, if the MFI value is 15, MFN value must be zero.

- ⁴ T_{dpdref} is the time period of the reference clock after predivider. According to the specification, the maximum lock time in FOL mode is 398 cycles of divided reference clock when DPLL starts after full reset.
- ⁵ T_{dck} is the time period of the output clock, dpdck_2 .

4.6.5 NAND Flash Controller (NFC) Parameters

This section provides the relative timing requirements among various signals of NFC at the module level, in each operational mode.

Timing parameters in Figure 10, Figure 11, Figure 12, Figure 13, Figure 15, and Table 36 show the default NFC mode (asymmetric mode) using two Flash clock cycles per one access of RE_B and WE_B.

Timing parameters in Figure 10, Figure 11, Figure 12, Figure 14, Figure 15, and Table 36 show symmetric NFC mode using one Flash clock cycle per one access of RE_B and WE_B.

With reference to the timing diagrams, a high is defined as 80% of signal value and low is defined as 20% of signal value. All parameters are given in nanoseconds. The BGA contact load used in calculations is 20 pF (except for NF16— 40 pF) and there is maximum drive strength on all contacts.

All timing parameters are a function of T, which is the period of the flash_clk clock (“enfc_clk” at system level). This clock frequency can be controlled by the user, configuring CCM (SoC clock controller). The clock is derived from emi_slow_clk after single divider.

Figure 35 demonstrates several examples of clock frequency settings.

Table 35. NFC Clock Settings Examples

emi_slow_clk (MHz)	nfc_podf (Division Factor)	enfc_clk (MHz)	T-Clock Period (ns)
100 (Boot mode)	7 ¹	14.29	70
	3 ²	33.33	30
133	4	33.33	30
	3	44.33 ³	22.5
	2	66 ³	15

¹ Boot value NFC_FREQ_SEL Fuse High (burned)

² Boot value NFC_FREQ_SEL Fuse Low

³ For RBB_MODE=1, using NANDF_RB0 signal for ready/busy indication. This mode require setting the delay line. See the Reference Manual for details.

NOTE

A potential limitation for minimum clock frequency may exist for some devices. When the clock frequency is too low, the data bus capturing might occur after the specified t_{rthoh} (RE_B high to output hold) period. Setting the clock frequency above 25.6 MHz (that is, $T = 39$ ns) guaranties a proper operation for devices having $t_{\text{rthoh}} > 15$ ns. It is also recommended that the NFC_FREQ_SEL Fuse be set accordingly to initiate the boot with 33.33 MHz clock.

Lower frequency operation can be supported for most available devices in the market, relying on data lines Bus-Keeper logic. This depends on device behavior on the data bus in the time interval between data output valid to data output high-Z state. In NAND device parameters this period is marked between $t_{r\text{hoh}}$ and $t_{r\text{hz}}$ (RE_B high to output high-Z). In most devices, the data transition from valid value to high-Z occurs without going through other states. Setting the data bus pads to Bus-Keeper mode in the IOMUXC registers, keeps the data bus valid internally after the specified hold time, allowing proper capturing with slower clock.

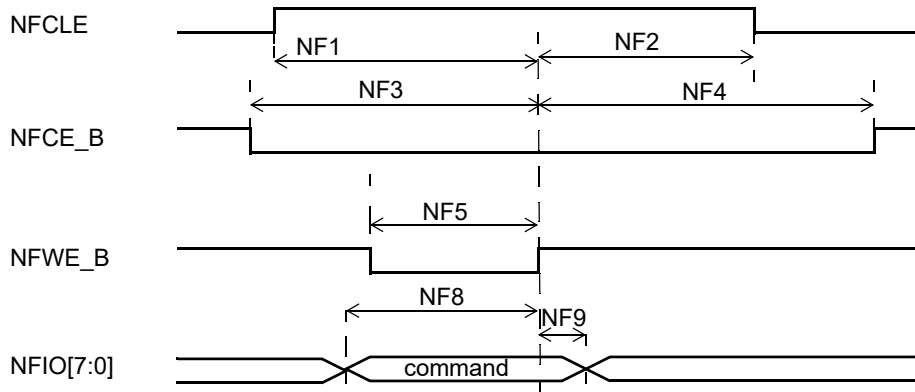

Figure 10. Command Latch Cycle Timing

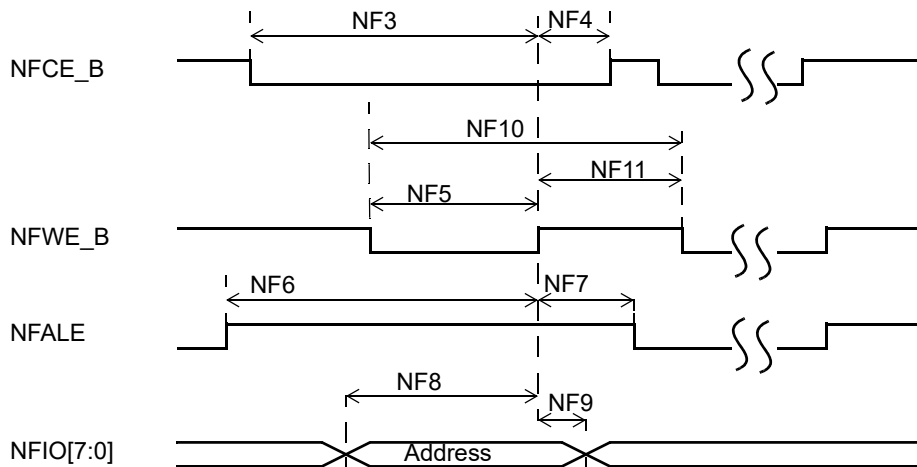

Figure 11. Address Latch Cycle Timing

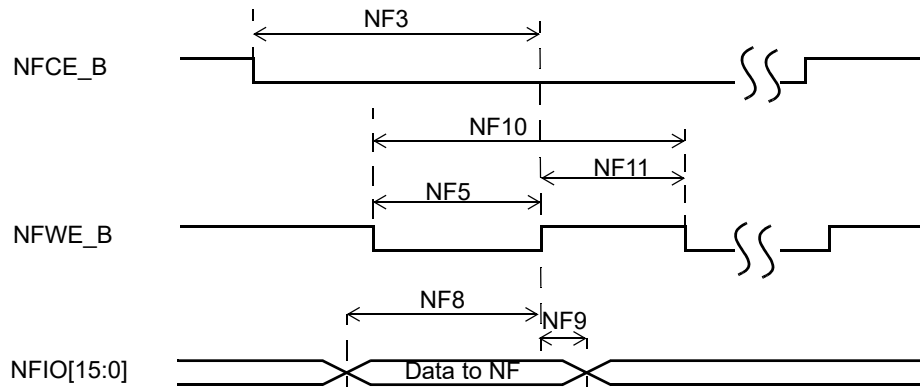

Figure 12. Write Data Latch Timing

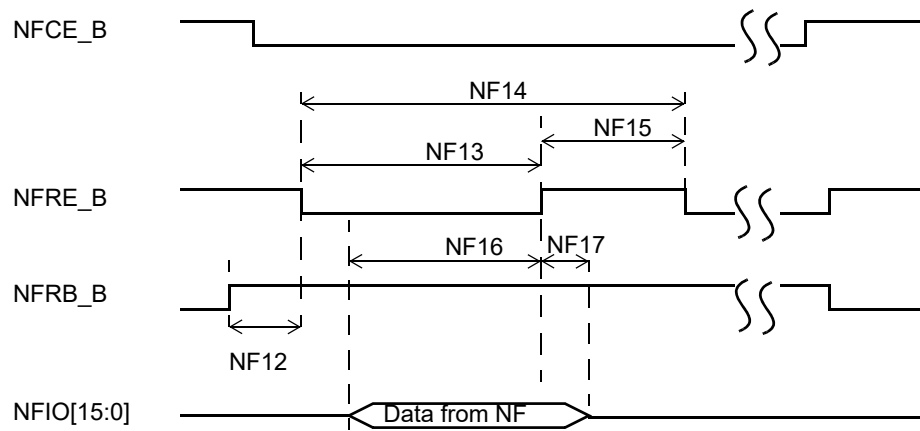

Figure 13. Read Data Latch Timing, Asymmetric Mode

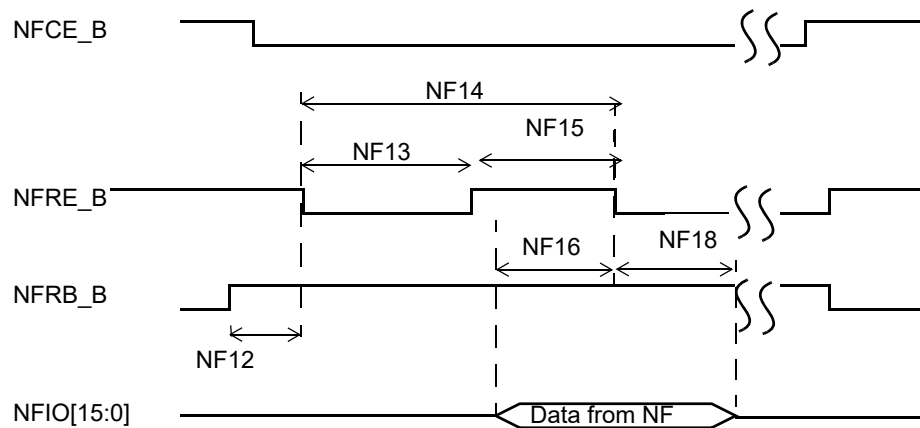

Figure 14. Read Data Latch Timing, Symmetric Mode

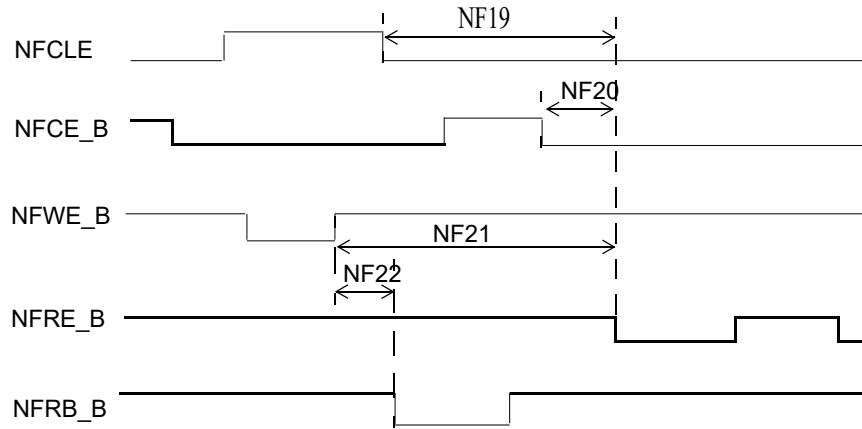

Figure 15. Other Timing Parameters

Table 36. NFC—Timing Characteristics

ID	Parameter	Symbol	Asymmetric Mode Min	Symmetric Mode Min	Max
NF1	NFCLE setup Time	tCLS	2T + 0.1	2T + 0.1	—
NF2	NFCLE Hold Time	tCLH	T - 4.45	T - 4.45	—
NF3 ¹	NFCE_B Setup Time	tCS	3T + 0.95	3T+0.95	—
NF4	NFCE_B Hold Time	tCH	2T-5.55	1.5T-5.55	—
NF5	NFWE_B Pulse Width	tWP	T - 1.4	0.5T - 1.4	—
NF6	NFALE Setup Time	tALS	2T + 0.1	2T + 0.1	—
NF7	NFALE Hold Time	tALH	T - 4.45	T - 4.45	—
NF8	Data Setup Time	tDS	T - 0.9	0.5T - 0.9	—
NF9	Data Hold Time	tDH	T - 5.55	0.5T - 5.55	—
NF10	Write Cycle Time	tWC	2T	T-0.5	—
NF11	NFWE_B Hold Time	tWH	T - 1.15	0.5T - 1.15	—
NF12	Ready to NFRE_B Low	tRR	9T + 8.9	9T + 8.9	—
NF13	NFRE_B Pulse Width	tRP	1.5T	0.5T-1	—
NF14	READ Cycle Time	tRC	2T	T	—
NF15	NFRE_B High Hold Time	tREH	0.5T - 1.15	0.5T - 1.15	—
NF16 ²	Data Setup on READ	tDSR	11.2 + 0.5T - Tdl ³	11.2 - Tdl ³	—
NF17 ⁴	Data Hold on READ	tDHR	0	—	2T _{ack} + T
NF18 ⁵	Data Hold on READ	tDHR	—	Tdl ³ - 11.2	2T _{ack} + T
NF19	CLE to RE delay	tCLR	9T	9T	—
NF20	CE to RE delay	tCRE	T - 3.45	T - 3.45	T + 0.3
NF21	WE high to RE low	tWHR	10.5T	10.5T	—
NF22	WE high to busy	tWB	—	—	6T

¹ In case of NUM_OF_DEVICES is greater than 0 (for example, interleaved mode), then only during the data phase of symmetric mode the setup time will equal 1.5T + 0.95.

² t_{DSR} is calculated by the following formula:

$$\text{Asymmetric mode: } t_{DSR} = t_{REpd} + t_{Dpd} + \frac{1}{2}T - Tdl^3$$

$$\text{Symmetric mode: } t_{DSR} = t_{REpd} + t_{Dpd} - Tdl^3$$

$$t_{REpd} + t_{Dpd} = 11.2 \text{ ns (including clock skew)}$$

where t_{REpd} is RE propagation delay in the chip including I/O pad delay, and t_{Dpd} is Data propagation delay from I/O pad to EXTMC including I/O pad delay.

t_{DSR} can be used to determine t_{REA} max parameter with the following formula: t_{REA} = 1.5T - t_{DSR}.

³ Tdl is composed of 4 delay-line units each generates an equal delay with min 1.25 ns and max 1 ack period (T_{ack}). Default is 1/4 ack period for each delay-line unit, so all 4 delay lines together generates a total of 1 ack period. T_{ack} is “emi_slow_clk” of the system, which default value is 7.5 ns (133 MHz).

Electrical Characteristics

⁴ NF17 is defined only in asymmetric operation mode.

NF17 max value is equivalent to max t_{RHZ} value that can be used with NFC.

T_{ack} is “emi_slow_clk” of the system.

⁵ NF18 is defined only in Symmetric operation mode.

t_{DHR} (MIN) is calculated by the following formula: $T_{dl}^3 - (t_{REpd} + t_{Dpd})$

where t_{REpd} is RE propagation delay in the chip including I/O pad delay, and t_{Dpd} is Data propagation delay from I/O pad to EXTMC including I/O pad delay.

NF18 max value is equivalent to max t_{RHZ} value that can be used with NFC.

T_{ack} is “emi_slow_clk” of the system.

4.6.6 External Interface Module (EIM)

The following subsections provide information on the EIM.

4.6.6.1 EIM Signal Cross Reference

Table 37 is a guide intended to help the user identify signals in the External Interface Module Chapter of the Reference Manual which are identical to those mentioned in this data sheet.

Table 37. EIM Signal Cross Reference

Reference Manual EIM Chapter Nomenclature	Data Sheet Nomenclature, Reference Manual External Signals and Pin Multiplexing Chapter, and IOMUXC Controller Chapter Nomenclature
BCLK	EIM_BCLK
CSx	EIM_CSx
WE_B	EIM_RW
OE_B	EIM_OE
BEy_B	EIM_EBx
ADV	EIM_LBA
ADDR	EIM_A[25:16], EIM_DA[15:0]
ADDR/M_DATA	EIM_DAx (Addr/Data muxed mode)
DATA	EIM_NFC_D (Data bus shared with NAND Flash) EIM_Dx (dedicated data bus)
WAIT_B	EIM_WAIT

4.6.6.2 EIM Interface Pads Allocation

EIM supports 16-bit and 8-bit devices operating in address/data separate or multiplexed modes. In some of the modes the EIM and the NAND FLASH have shared data bus. Table 39 provides EIM interface pads allocation in different modes.

Table 39. EIM Internal Module Multiplexing

Setup	Non Multiplexed Address/Data Mode						Multiplexed Address/Data mode	
	8 Bit			16 Bit		32 Bit	16 Bit	32 Bit
	MUM = 0, DSZ = 100	MUM = 0, DSZ = 101	MUM = 0, DSZ = 111	MUM = 0, DSZ = 001	MUM = 0, DSZ = 010	MUM = 0, DSZ = 011	MUM = 1, DSZ = 001	MUM = 1, DSZ = 011
A[15:0]	EIM_DA [15:0]	EIM_DA [15:0]	EIM_DA [15:0]	EIM_DA [15:0]	EIM_DA [15:0]	EIM_DA [15:0]	EIM_DA [15:0]	EIM_DA [15:0]
A[25:16]	EIM_A [25:16]	EIM_A [25:16]	EIM_A [25:16]	EIM_A [25:16]	EIM_A [25:16]	EIM_A [24:16] ¹	EIM_A [25:16]	NANDF_D [8:0] ¹
D[7:0], EIM_EB0	NANDF_D [7:0] ²	—	—	NANDF_D [7:0] ²	—	NANDF_D [7:0]	EIM_DA [7:0]	EIM_DA [7:0]
D[15:8], EIM_EB1	—	NANDF_D [15:8] ³	—	NANDF_D [15:8] ³	—	NANDF_D [15:8]	EIM_DA [15:8]	EIM_DA [15:8]
D[23:16], EIM_EB2	—	—	—	—	EIM_D [23:16]	EIM_D [23:16]	—	NANDF_D [7:0]
D[31:24], EIM_EB3	—	—	EIM_D [31:24]	—	EIM_D [31:24]	EIM_D [31:24]	—	NANDF_D [15:8]

¹ For 32-bit mode, the address range is A[24:0], due to address space allocation in memory map.

² NANDF_D[7:0] multiplexed on ALT3 mode of PATA_DATA[7:0]

³ NANDF_D[15:8] multiplexed on ALT3 mode of PATA_DATA[15:8]

4.6.6.3 General EIM Timing-Synchronous Mode

Figure 16, Figure 17, and Table 40 specify the timings related to the EIM module. All EIM output control signals may be asserted and deasserted by an internal clock synchronized to the BCLK rising edge according to corresponding assertion/negation control fields.

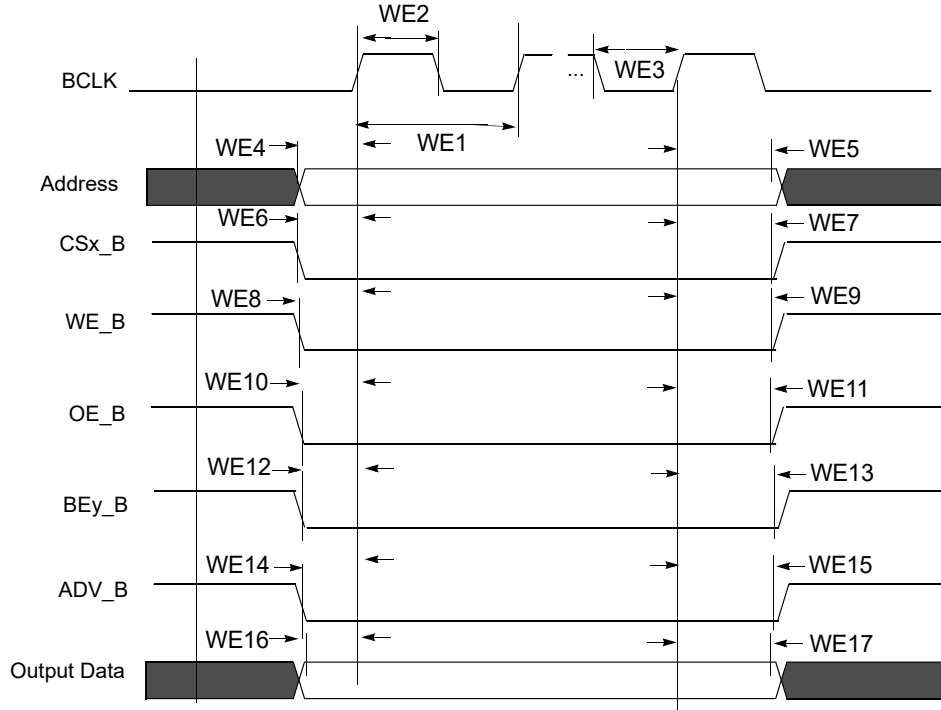

Figure 16. EIM Outputs Timing Diagram

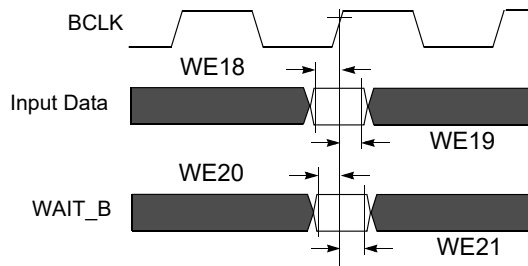

Figure 17. EIM Inputs Timing Diagram

Table 40. EIM Bus Timing Parameters ¹

ID	Parameter	BCD = 0		BCD = 1		BCD = 2		BCD = 3	
		Min	Max	Min	Max	Min	Max	Min	Max
WE1	BCLK Cycle time ²	t		2 x t		3 x t		4 x t	
WE2	BCLK Low Level Width	0.4 x t		0.8 x t		1.2 x t		1.6 x t	

Table 40. EIM Bus Timing Parameters (continued)¹

ID	Parameter	BCD = 0		BCD = 1		BCD = 2		BCD = 3	
		Min	Max	Min	Max	Min	Max	Min	Max
WE3	BCLK High Level Width	$0.4 \times t$		$0.8 \times t$		$1.2 \times t$		$1.6 \times t$	
WE4	Clock rise to address valid ³	$-0.5 \times t - 1.25$	$-0.5 \times t + 1.75$	$t - 1.25$	$t + 1.75$	$-1.5 \times t - 1.25$	$-1.5 \times t + 1.75$	$-2 \times t - 1.25$	$-2 \times t + 1.75$
WE5	Clock rise to address invalid	$0.5 \times t - 1.25$	$0.5 \times t + 1.75$	$t - 1.25$	$t + 1.75$	$1.5 \times t - 1.25$	$1.5 \times t + 1.75$	$2 \times t - 1.25$	$2 \times t + 1.75$
WE6	Clock rise to CSx_B valid	$-0.5 \times t - 1.25$	$-0.5 \times t + 1.75$	$t - 1.25$	$t + 1.75$	$-1.5 \times t - 1.25$	$-1.5 \times t + 1.75$	$-2 \times t - 1.25$	$-2 \times t + 1.75$
WE7	Clock rise to CSx_B invalid	$0.5 \times t - 1.25$	$0.5 \times t + 1.75$	$t - 1.25$	$t + 1.75$	$1.5 \times t - 1.25$	$1.5 \times t + 1.75$	$2 \times t - 1.25$	$2 \times t + 1.75$
WE8	Clock rise to WE_B Valid	$-0.5 \times t - 1.25$	$-0.5 \times t + 1.75$	$t - 1.25$	$t + 1.75$	$-1.5 \times t - 1.25$	$-1.5 \times t + 1.75$	$-2 \times t - 1.25$	$-2 \times t + 1.75$
WE9	Clock rise to WE_B Invalid	$0.5 \times t - 1.25$	$0.5 \times t + 1.75$	$t - 1.25$	$t + 1.75$	$1.5 \times t - 1.25$	$1.5 \times t + 1.75$	$2 \times t - 1.25$	$2 \times t + 1.75$
WE10	Clock rise to OE_B Valid	$-0.5 \times t - 1.25$	$-0.5 \times t + 1.75$	$t - 1.25$	$t + 1.75$	$-1.5 \times t - 1.25$	$-1.5 \times t + 1.75$	$-2 \times t - 1.25$	$-2 \times t + 1.75$
WE11	Clock rise to OE_B Invalid	$0.5 \times t - 1.25$	$0.5 \times t + 1.75$	$t - 1.25$	$t + 1.75$	$1.5 \times t - 1.25$	$1.5 \times t + 1.75$	$2 \times t - 1.25$	$2 \times t + 1.75$
WE12	Clock rise to BEy_B Valid	$-0.5 \times t - 1.25$	$-0.5 \times t + 1.75$	$t - 1.25$	$t + 1.75$	$-1.5 \times t - 1.25$	$-1.5 \times t + 1.75$	$-2 \times t - 1.25$	$-2 \times t + 1.75$
WE13	Clock rise to BEy_B Invalid	$0.5 \times t - 1.25$	$0.5 \times t + 1.75$	$t - 1.25$	$t + 1.75$	$1.5 \times t - 1.25$	$1.5 \times t + 1.75$	$2 \times t - 1.25$	$2 \times t + 1.75$
WE14	Clock rise to ADV_B Valid	$-0.5 \times t - 1.25$	$-0.5 \times t + 1.75$	$t - 1.25$	$t + 1.75$	$-1.5 \times t - 1.25$	$-1.5 \times t + 1.75$	$-2 \times t - 1.25$	$-2 \times t + 1.75$
WE15	Clock rise to ADV_B Invalid	$0.5 \times t - 1.25$	$0.5 \times t + 1.75$	$t - 1.25$	$t + 1.75$	$1.5 \times t - 1.25$	$1.5 \times t + 1.75$	$2 \times t - 1.25$	$2 \times t + 1.75$
WE16	Clock rise to Output Data Valid	$-0.5 \times t - 1.25$	$-0.5 \times t + 1.75$	$t - 1.25$	$t + 1.75$	$-1.5 \times t - 1.25$	$-1.5 \times t + 1.75$	$-2 \times t - 1.25$	$-2 \times t + 1.75$
WE17	Clock rise to Output Data Invalid	$0.5 \times t - 1.25$	$0.5 \times t + 1.75$	$t - 1.25$	$t + 1.75$	$1.5 \times t - 1.25$	$1.5 \times t + 1.75$	$2 \times t - 1.25$	$2 \times t + 1.75$
WE18	Input Data setup time to Clock rise	2 ns	—	4 ns	—	—	—	—	—
WE19	Input Data hold time from Clock rise	2 ns	—	2 ns	—	—	—	—	—
WE20	WAIT_B setup time to Clock rise	2 ns	—	4 ns	—	—	—	—	—
WE21	WAIT_B hold time from Clock rise	2 ns	—	2 ns	—	—	—	—	—

Electrical Characteristics

- ¹ t is the maximal EIM logic (axi_clk) cycle time. The maximum allowed axi_clk frequency is 133 MHz, whereas the maximum allowed BCLK frequency is 104 MHz. As a result, if BCD = 0, axi_clk must be ≤ 104 MHz. If BCD = 1, then 133 MHz is allowed for axi_clk, resulting in a BCLK of 66.5 MHz. When the clock branch to EIM is decreased to 104 MHz, other busses are impacted which are clocked from this source. See the CCM chapter of the i.MX53 Reference Manual for a detailed clock tree description.
- ² BCLK parameters are being measured from the 50% point, that is, high is defined as 50% of signal value and low is defined as 50% as signal value.
- ³ For signal measurements “High” is defined as 80% of signal value and “Low” is defined as 20% of signal value.

4.6.6.4 Examples of EIM Synchronous Accesses

Figure 18 to Figure 21 provide few examples of basic EIM accesses to external memory devices with the timing parameters mentioned previously for specific control parameters settings.

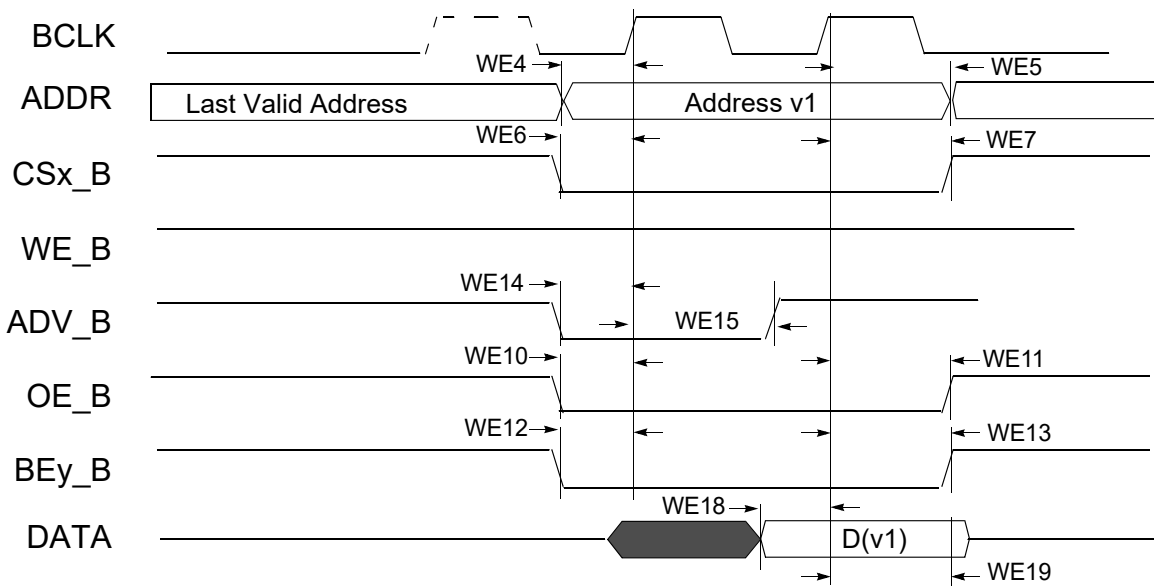

Figure 18. Synchronous Memory Read Access, WSC=1

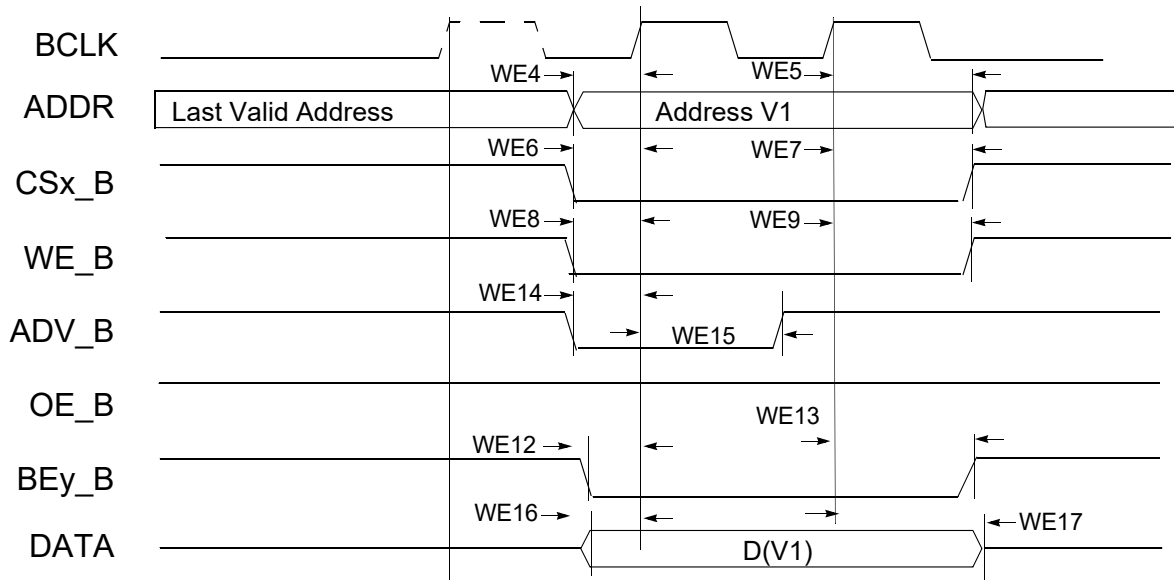

Figure 19. Synchronous Memory, Write Access, WSC=1, WBEA=0, and WADVN=0

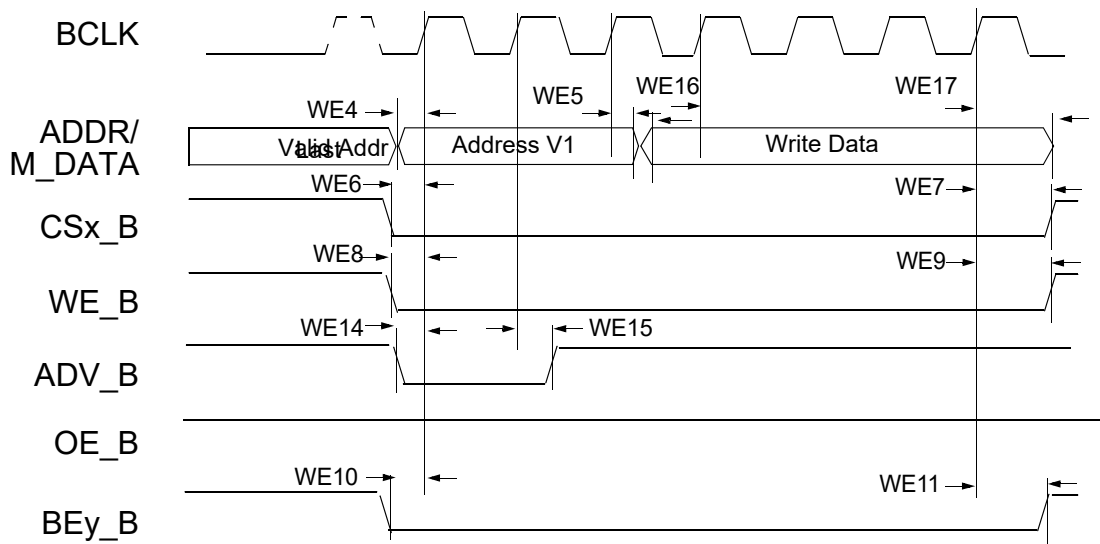

Figure 20. Muxed Address/Data (A/D) Mode, Synchronous Write Access, WSC=6, ADVA=0, ADVN=1, and ADH=1

NOTE

In 32-bit muxed address/data (A/D) mode the 16 MSBs are driven on the data bus.

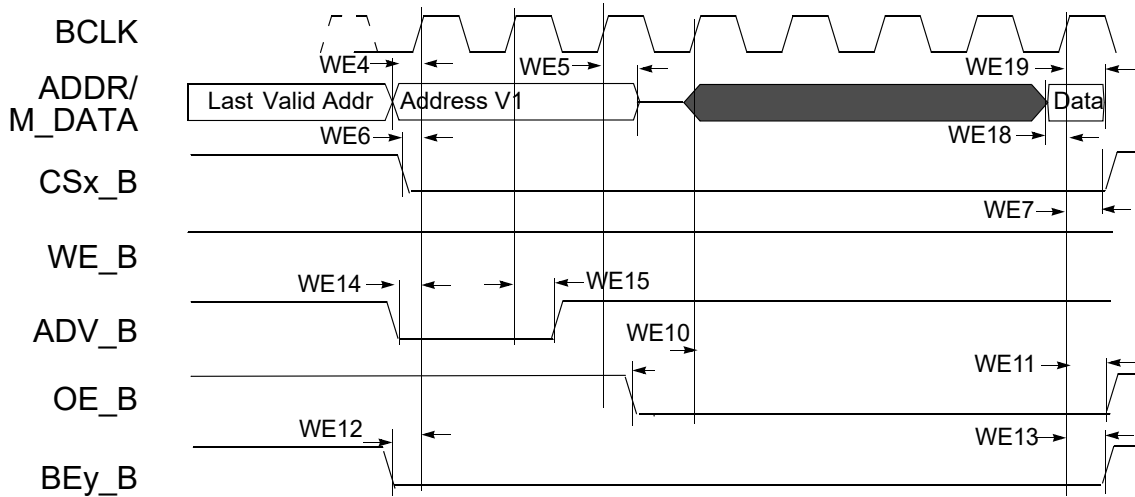

Figure 21. 16-Bit Muxed A/D Mode, Synchronous Read Access, WSC=7, RADVN=1, ADH=1, and OEA=0

4.6.6.5 General EIM Timing-Asynchronous Mode

Figure 22 through Figure 27, and Table 41 help to determine timing parameters relative to the chip select (CS) state for asynchronous and DTACK EIM accesses with corresponding EIM bit fields and the timing parameters mentioned above.

Asynchronous read and write access length in cycles may vary from what is shown in Figure 22 through Figure 25 as RWSC, OEN, and CSN is configured differently. See i.MX53 reference manual for the EIM programming model.

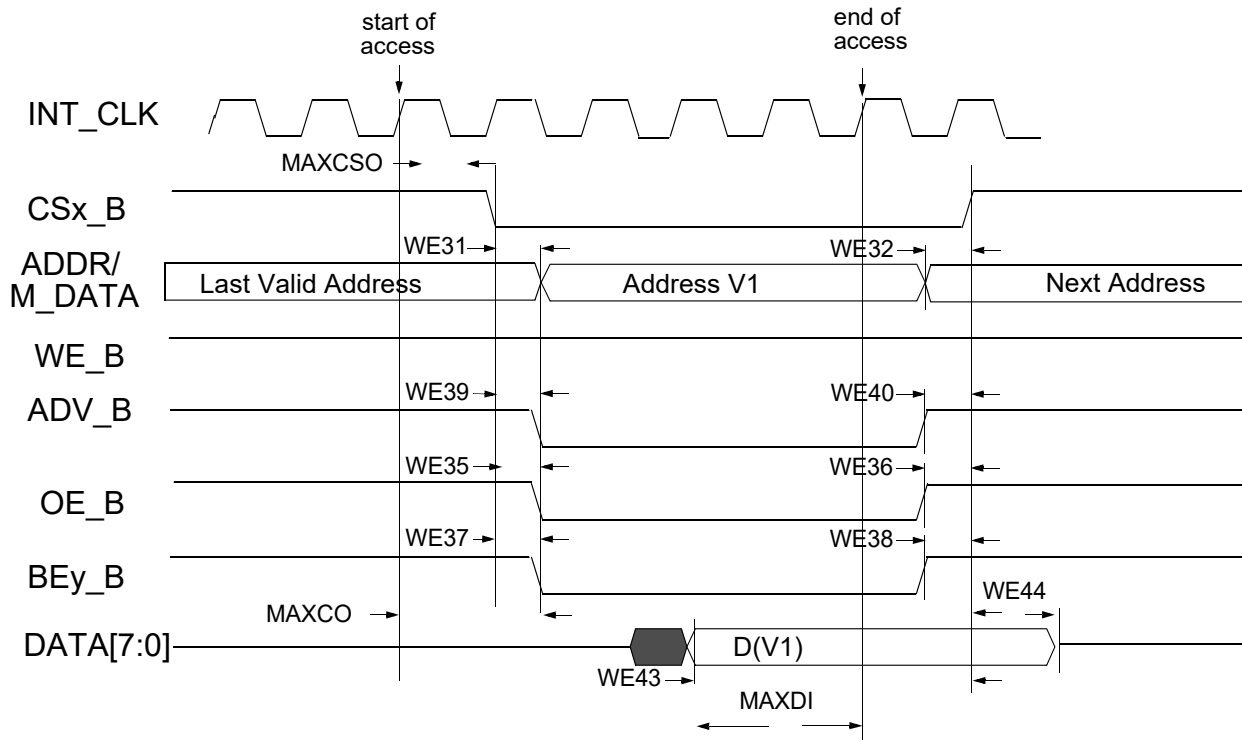

Figure 22. Asynchronous Memory Read Access (RWSC = 5)

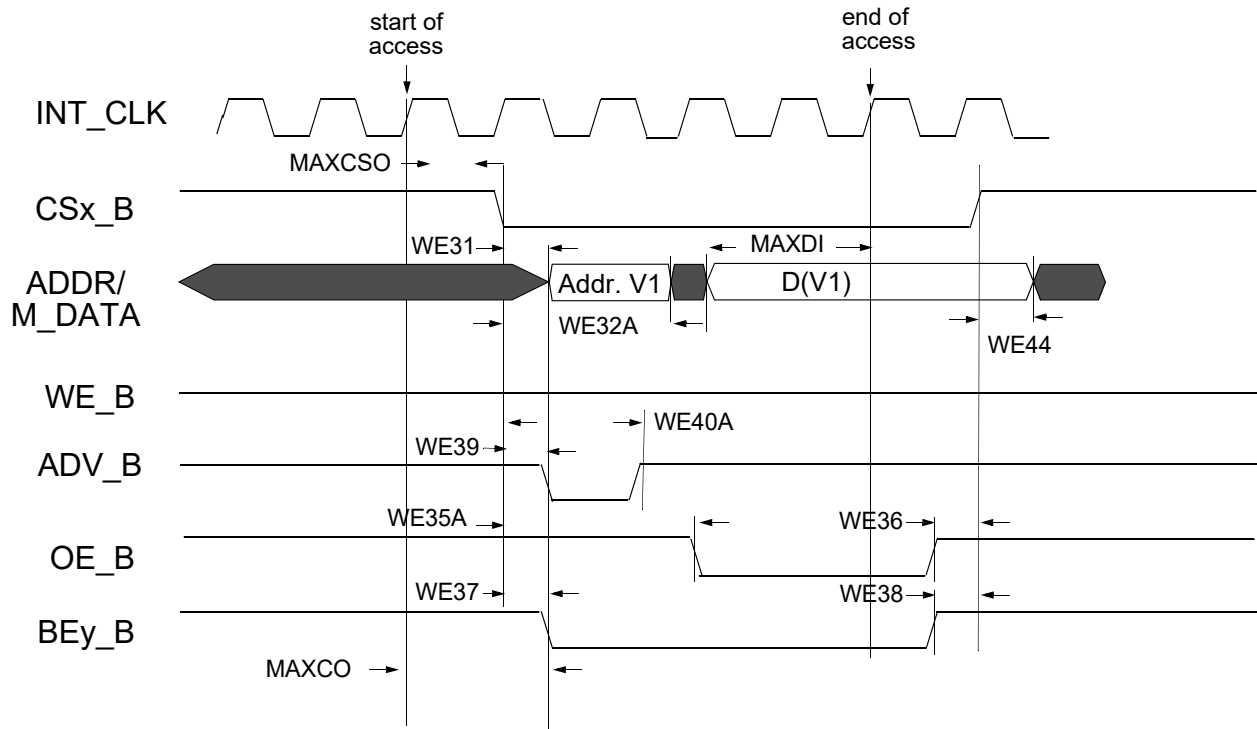

Figure 23. Asynchronous A/D Muxed Read Access (RWSC = 5)

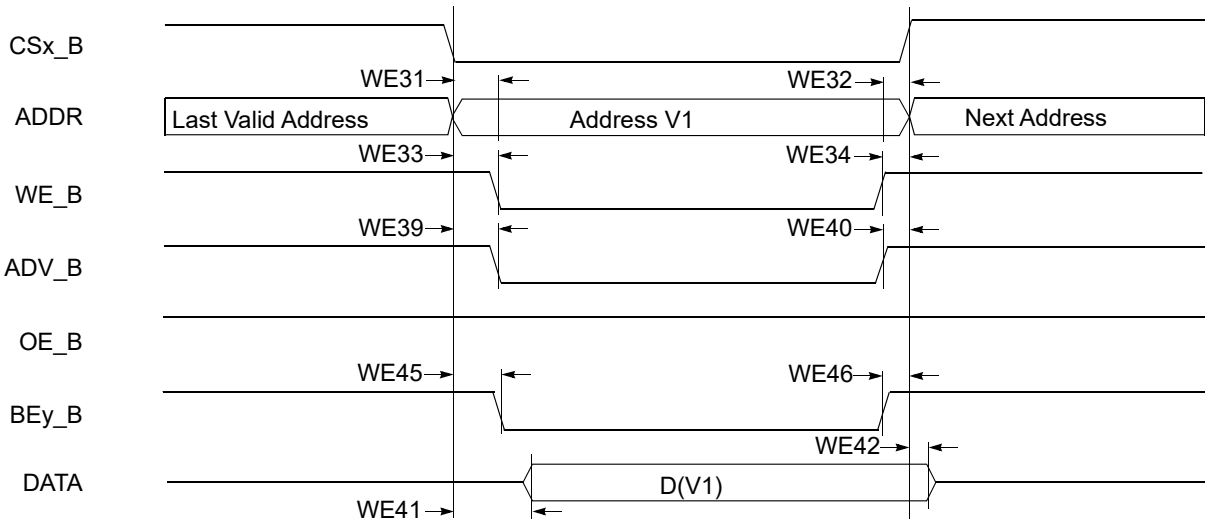

Figure 24. Asynchronous Memory Write Access

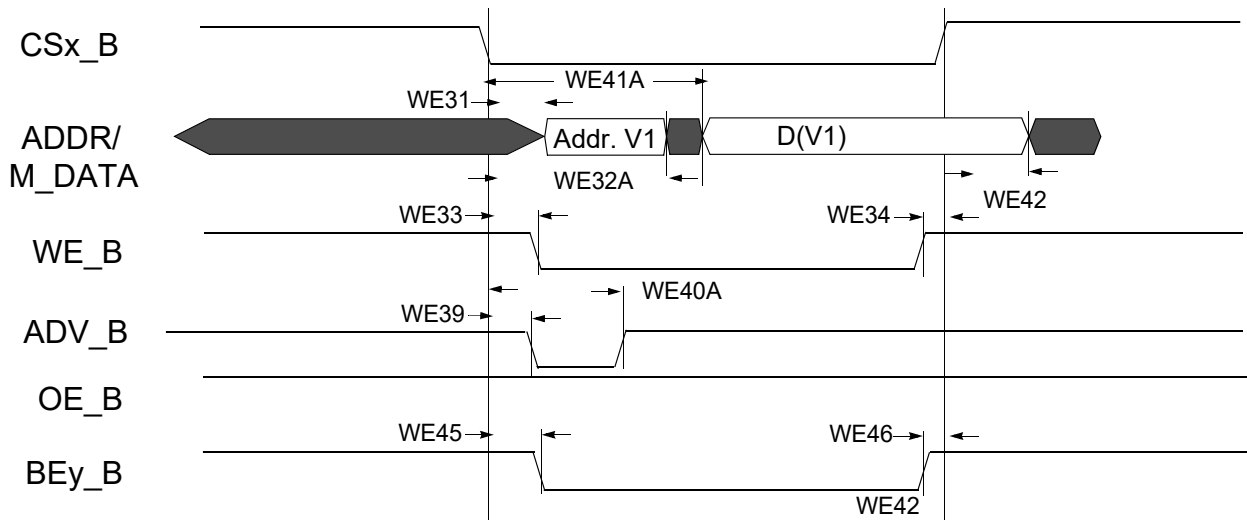

Figure 25. Asynchronous A/D Muxed Write Access

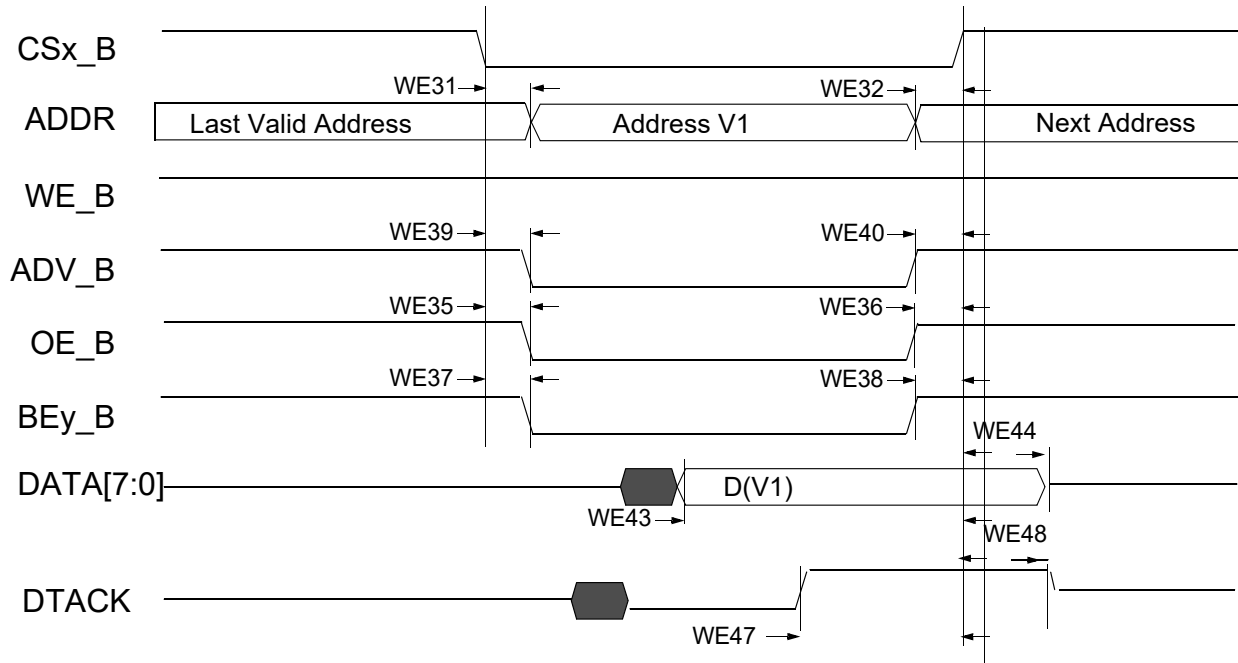

Figure 26. DTACK Read Access (DAP=0)

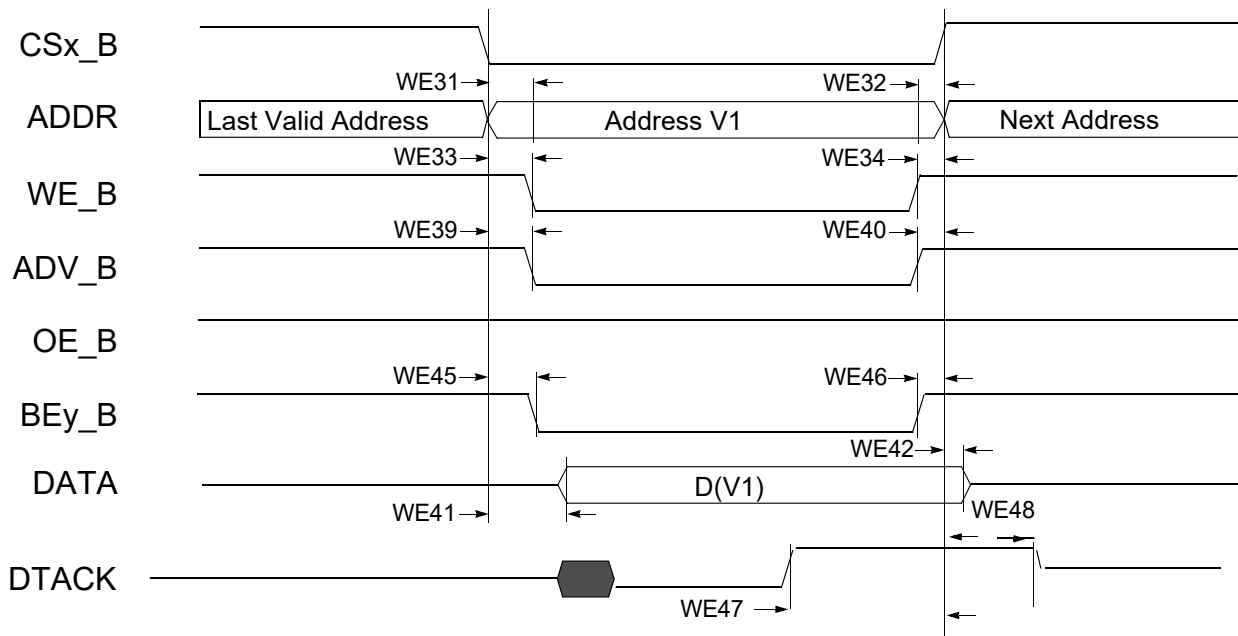

Figure 27. DTACK Write Access (DAP=0)

Table 41. EIM Asynchronous Timing Parameters Table Relative Chip Select

Ref No.	Parameter	Determination by Synchronous measured parameters ¹²	Min	Max (If 133 MHz is supported by SOC)	Unit
WE31	CSx_B valid to Address Valid	WE4 - WE6 - CSA ³	—	3 - CSA	ns
WE32	Address Invalid to CSx_B invalid	WE7 - WE5 - CSN ⁴	—	3 - CSN	ns
WE32A(muxed A/D)	CSx_B valid to Address Invalid	t ⁵ + WE4 - WE7 + (ADV _N + ADVA + 1 - CSA ³)	-3 + (ADV _N + ADVA + 1 - CSA)	—	ns
WE33	CSx_B Valid to WE_B Valid	WE8 - WE6 + (WEA - CSA)	—	3 + (WEA - CSA)	ns
WE34	WE_B Invalid to CSx_B Invalid	WE7 - WE9 + (WEN - CSN)	—	3 - (WEN - CSN)	ns
WE35	CSx_B Valid to OE_B Valid	WE10 - WE6 + (OEA - CSA)	—	3 + (OEA - CSA)	ns
WE35A(muxed A/D)	CSx_B Valid to OE_B Valid	WE10 - WE6 + (OEA + RADV _N + RADVA + ADH + 1 - CSA)	-3 + (OEA + RADV _N + RADVA + ADH + 1 - CSA)	3 + (OEA + RADV _N + RADVA + ADH + 1 - CSA)	ns
WE36	OE_B Invalid to CSx_B Invalid	WE7 - WE11 + (OEN - CSN)	—	3 - (OEN - CSN)	ns
WE37	CSx_B Valid to BEy_B Valid (Read access)	WE12 - WE6 + (RBEA - CSA)	—	3 + (RBEA ⁶ - CSA)	ns
WE38	BEy_B Invalid to CSx_B Invalid (Read access)	WE7 - WE13 + (RBEN - CSN)	—	3 - (RBEN ⁷ - CSN)	ns
WE39	CSx_B Valid to ADV_B Valid	WE14 - WE6 + (ADVA - CSA)	—	3 + (ADVA - CSA)	ns
WE40	ADV_B Invalid to CSx_B Invalid (ADVL is asserted)	WE7 - WE15 - CSN	—	3 - CSN	ns
WE40A(muxed A/D)	CSx_B Valid to ADV_B Invalid	WE14 - WE6 + (ADV _N + ADVA + 1 - CSA)	-3 + (ADV _N + ADVA + 1 - CSA)	3 + (ADV _N + ADVA + 1 - CSA)	ns
WE41	CSx_B Valid to Output Data Valid	WE16 - WE6 - WCSA	—	3 - WCSA	ns
WE41A(muxed A/D)	CSx_B Valid to Output Data Valid	WE16 - WE6 + (WADV _N + WADVA + ADH + 1 - WCSA)	—	3 + (WADV _N + WADVA + ADH + 1 - WCSA)	ns
WE42	Output Data Invalid to CSx_B Invalid	WE17 - WE7 - CSN	—	3 - CSN	ns
MAXCO	Output max. delay from internal driving ADDR/control FFs to chip outputs.	10	—	—	ns
MAXCSO	Output max. delay from CSx internal driving FFs to CSx out.	10	—	—	
MAXDI	DATA MAXIMUM delay from chip input data to its internal FF	5	—	—	

Table 41. EIM Asynchronous Timing Parameters Table Relative Chip Select

Ref No.	Parameter	Determination by Synchronous measured parameters ¹²	Min	Max (If 133 MHz is supported by SOC)	Unit
WE43	Input Data Valid to CSx_B Invalid	MAXCO - MAXCSO + MAXDI	MAXCO - MAXCSO + MAXDI	—	ns
WE44	CSx_B Invalid to Input Data invalid	0	0	—	ns
WE45	CSx_B Valid to BEy_B Valid (Write access)	WE12 - WE6 + (WBEA - CSA)	—	3 + (WBEA - CSA)	ns
WE46	BEy_B Invalid to CSx_B Invalid (Write access)	WE7 - WE13 + (WBEN - CSN)	—	-3 + (WBEN - CSN)	ns
MAXDTI	DTACK MAXIMUM delay from chip dtack input to its internal FF + 2 cycles for synchronization		—	—	—
WE47	Dtack Active to CSx_B Invalid	MAXCO - MAXCSO + MAXDTI	MAXCO - MAXCSO + MAXDTI	—	ns
WE48	CSx_B Invalid to Dtack invalid	0	0	—	ns

¹ Parameters WE4... WE21 value see column BCD = 0 in Table 40.

² All config. parameters (CSA, CSN, WBEA, WBEN, ADVA, ADVN, OEN, OEA, RBEA & RBEN) are in cycle units.

³ CS Assertion. This bit field determines when CS signal is asserted during read/write cycles.

⁴ CS Negation. This bit field determines when CS signal is negated during read/write cycles.

⁵ t is axi_clk cycle time.

⁶ BE Assertion. This bit field determines when BE signal is asserted during read cycles.

⁷ BE Negation. This bit field determines when BE signal is negated during read cycles.

4.6.7 DDR SDRAM Specific Parameters (DDR2/LVDDR2, LPDDR2, and DDR3)

The DDR2/LVDDR2 interface fully complies with JESD79-2E – DDR2 JEDEC release April, 2008, supporting DDR2-800 and LVDDR2-800.

The DDR3 interface fully complies with JESD79-3D – DDR3 JEDEC release April 2008 supporting DDR3-800.

The LPDDR2 interface fully complies with JESD209-2B, supporting LPDDR2-800.

Electrical Characteristics

Figure 28 and Table 42 show the address and control timing parameters for DDR2 and DDR3.

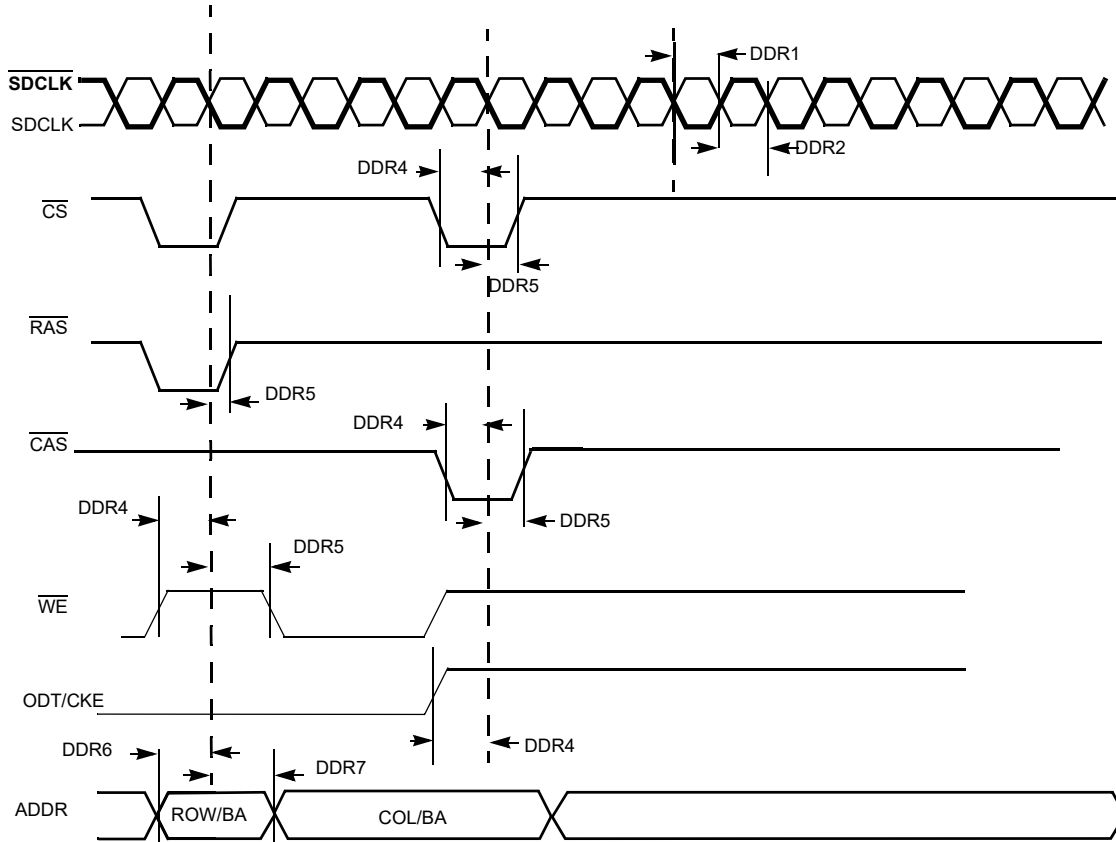

Figure 28. DDR SDRAM Address and Control Parameters for DDR2 and DDR3

Table 42. DDR SDRAM Timing Parameter Table^{1 2}

ID	Parameter	Symbol	SDCLK = 400 MHz		Units
			Min	Max	
DDR1	SDRAM clock high-level width	tCH	0.48	0.52	tck
DDR2	SDRAM clock low-level width	tCL	0.48	0.52	tck
DDR4	CS, RAS, CAS, CKE, WE, ODT setup time	tIS	0.6	—	ns
DDR5	CS, RAS, CAS, CKE, WE, ODT hold time	tIH	0.6	—	ns
DDR6	Address output setup time	tIS	0.6	—	ns
DDR7	Address output hold time	tIH	0.6	—	ns

¹ All timings are refer to Vref level cross point.

² Reference load model is 25 Ω resistor from each of the DDR outputs to VDD_REF.

Figure 29 and Table 43 show the address and control timing parameters for LPDDR2.

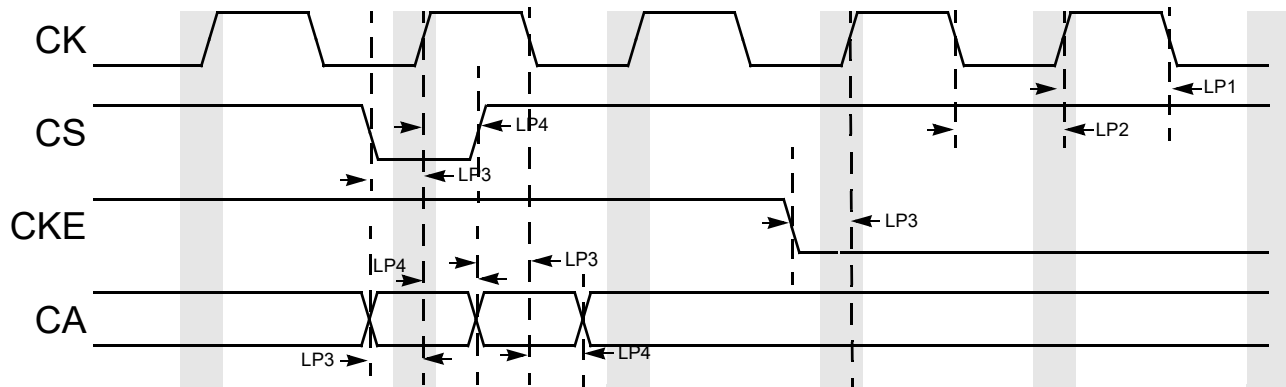

Figure 29. DDR SDRAM Address and Control Timing Parameters for LPDDR2

Table 43. DDR SDRAM Timing Parameter Table for LPDDR2^{1 2}

ID	Parameter	Symbol	SDCLK = 400 MHz		Units
			Min	Max	
LP1	SDRAM clock high-level width	tCH	0.45	0.55	tck
LP2	SDRAM clock low-level width	tCL	0.45	0.55	tck
LP3	CS, CKE setup time	tIS	0.3	—	ns
LP4	CS, CKE hold time	tIH	0.3	—	ns
LP3	CA setup time	tIS	0.3	—	ns
LP4	CA hold time	tIH	0.3	—	ns

¹ All timings are refer to Vref level cross point.

² Reference load model is 25 Ω resistor from each of the DDR outputs to VDD_REF.

Figure 30 and Table 44 show the data write timing parameters.

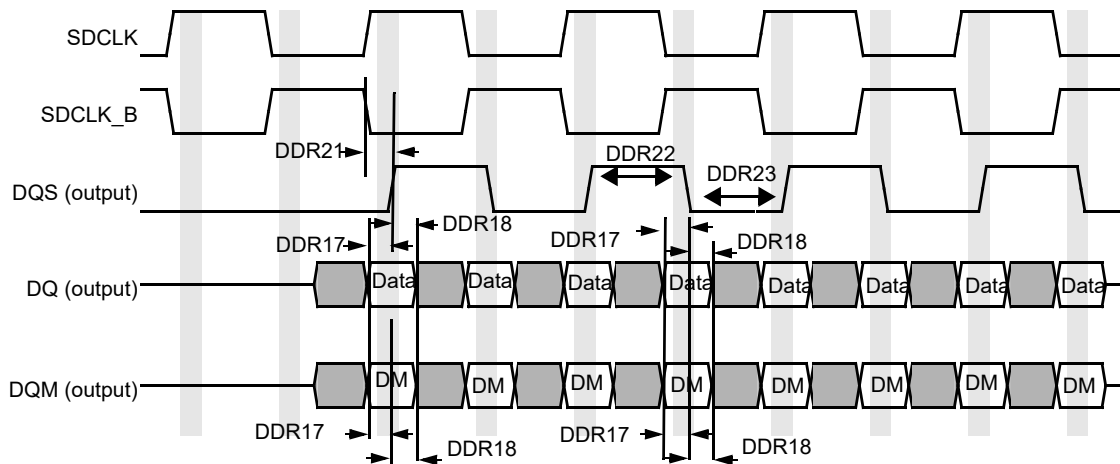

Figure 30. DDR SDRAM Data Write Cycle

Table 44. DDR SDRAM Write Cycle ^{1 2 3}

ID	Parameter	Symbol	SDCLK = 400 MHz		Unit
			Min	Max	
DDR17	DQ and DQM setup time to DQS (differential strobe)	t _{DS}	0.285	—	ns
DDR18	DQ and DQM hold time to DQS (differential strobe)	t _{DH}	0.285	—	ns
DDR21	DQS latching rising transitions to associated clock edges	t _{DQSS}	-0.25	+0.25	tCK
DDR22	DQS high level width	t _{DQSH}	0.45	0.55	tCK
DDR23	DQS low level width	t _{DQSL}	0.45	0.55	tCK

¹ All timings are refer to Vref level cross point.

² Reference load model is 25 Ω resistor from each of the DDR outputs to VDD_REF.

³ To receive the reported setup and hold values, write calibration should be performed in order to locate the DQS in the middle of DQ window.

Figure 31 and Table 45 show the data read timing parameters.

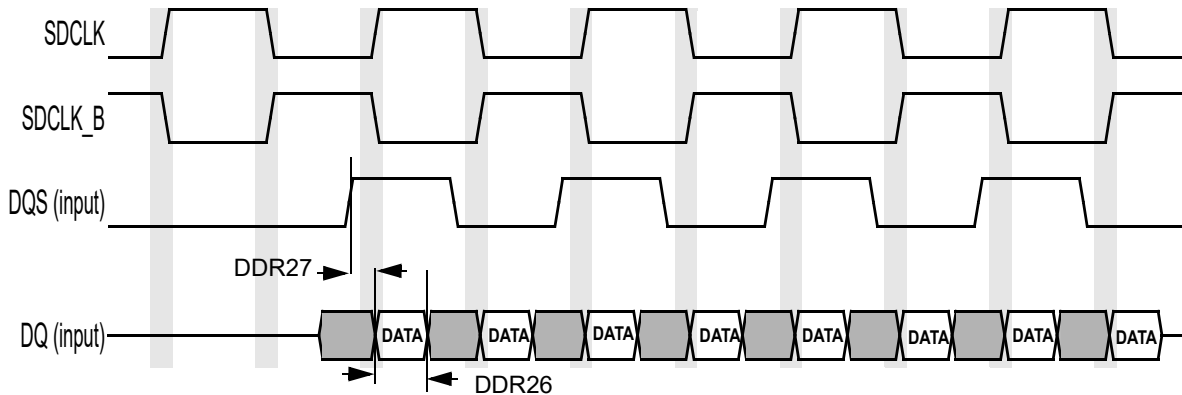

Figure 31. DDR SDRAM DQ vs. DQS and SDCLK Read Cycle

Table 45. DDR SDRAM Read Cycle ¹

ID	Parameter	Symbol	SDCLK = 400 MHz		Unit
			Min	Max	
DDR26	Minimum required DQ valid window width except from LPDDR2	—	0.6	—	ns
DDR26(LP DDR2)	Minimum required DQ valid window width for LPDDR2	—	0.425	—	ns
DDR27	DQS to DQ valid data	—	0.275	0.475	ns

¹ To receive the reported setup and hold values, read calibration should be performed in order to locate the DQS in the middle of DQ window.

4.7 External Peripheral Interfaces Parameters

The following subsections provide information on external peripheral interfaces.

4.7.1 AUDMUX Timing Parameters

The AUDMUX provides a programmable interconnect logic for voice, audio and data routing between internal serial interfaces (SSIs) and external serial interfaces (audio and voice codecs). The AC timing of AUDMUX external pins is governed by the SSI module. For more information, see the respective SSI electrical specifications found within this document.

4.7.2 CSPI and ECSPi Timing Parameters

This section describes the timing parameters of the CSPI and ECSPi blocks. The CSPI and ECSPi have separate timing parameters for master and slave modes. The nomenclature used with the CSPI / ECSPi modules and the respective routing of these signals is shown in [Table 46](#).

Table 46. CSPI Nomenclature and Routing

Block Instance	I/O Access
ECSPi-1	GPIO, KPP, DISP0_DAT, CSI0_DAT and EIM_D through IOMUXC
ECSPi-2	DISP0_DAT, CSI0_DAT and EIM through IOMUXC
CSPI	DISP0_DAT, EIM_A/D, SD1 and SD2 through IOMUXC

4.7.2.1 CSPI Master Mode Timing

[Figure 32](#) depicts the timing of CSPI in master mode. [Table 47](#) lists the CSPI master mode timing characteristics.

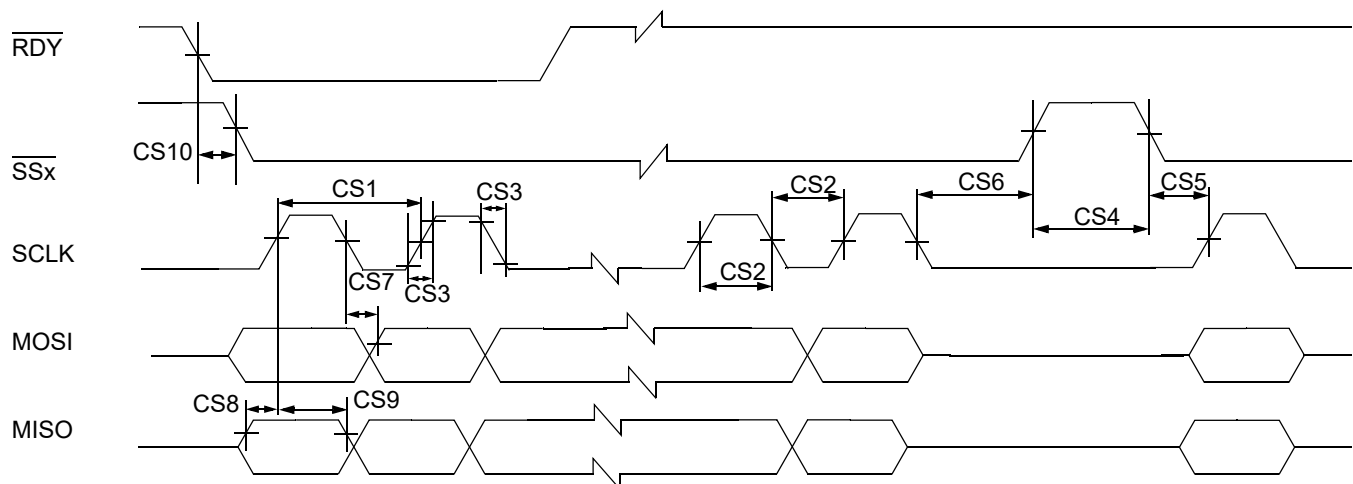

Figure 32. CSPI/ECSPi Master Mode Timing Diagram

Table 47. CSPI Master Mode Timing Parameters

ID	Parameter	Symbol	Min	Max	Unit
CS1	SCLK Cycle Time	t_{clk}	60	—	ns
CS2	SCLK High or Low Time	t_{sw}	26	—	ns
CS3	SCLK Rise or Fall ¹	$t_{RISE/FALL}$	—	—	ns
CS4	SSx pulse width	t_{CSLH}	26	—	ns
CS5	SSx Lead Time (Slave Select setup time)	t_{SCS}	26	—	ns
CS6	SSx Lag Time (SS hold time)	t_{HCS}	26	—	ns
CS7	MOSI Propagation Delay ($C_{LOAD} = 20\text{ pF}$)	t_{pDmosi}	-1	21	ns
CS8	MISO Setup Time	t_{Smiso}	5	—	ns
CS9	MISO Hold Time	t_{Hmiso}	5	—	ns
CS10	RDY to SSx Time ²	t_{SDRY}	5	—	ns

¹ See specific I/O AC parameters [Section 4.5, "I/O AC Parameters"](#)

² SPI_RDY is sampled internally by ipg_clk and is asynchronous to all other CSPI signals.

4.7.2.2 CSPI Slave Mode Timing

Figure 33 depicts the timing of CSPI in slave mode. Timing characteristics were not available at the time of publication.

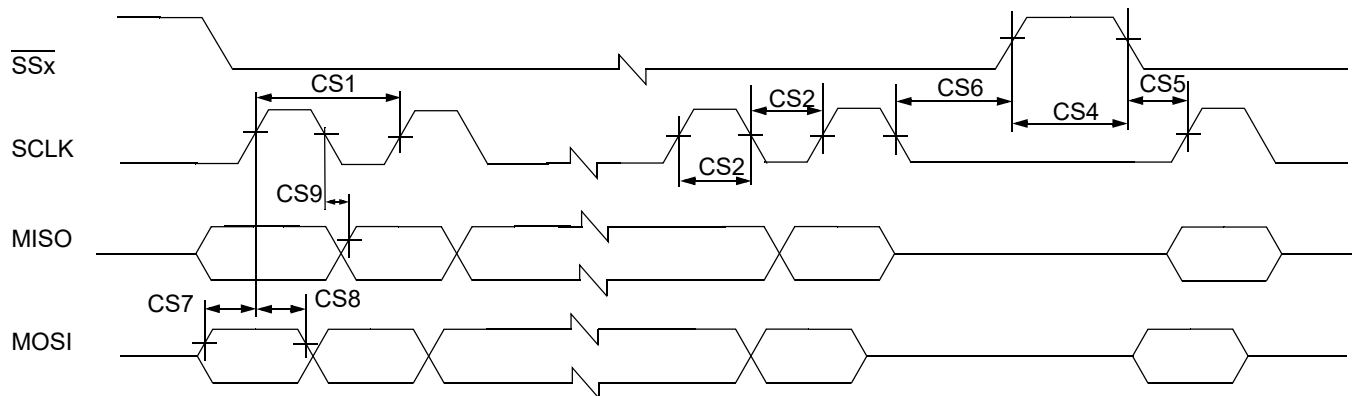

Figure 33. CSPI/ECSPI Slave Mode Timing Diagram

4.7.2.3 ECSPi Master Mode Timing

Figure 32 depicts the timing of ECSPi in master mode. Table 49 lists the ECSPi master mode timing characteristics.

Table 49. ECSPi Master Mode Timing Parameters

ID	Parameter	Symbol	Min	Max	Unit
CS1	SCLK Cycle Time—Read SCLK Cycle Time—Write	t_{clk}	30 15	—	ns
CS2	SCLK High or Low Time—Read SCLK High or Low Time—Write	t_{sw}	14 7	—	ns
CS3	SCLK Rise or Fall ¹	$t_{RISE/FALL}$	—	—	ns
CS4	SSx pulse width	t_{CSLH}	Half SCLK period	—	ns
CS5	SSx Lead Time (CS setup time)	t_{SCS}	5	—	ns
CS6	SSx Lag Time (CS hold time)	t_{HCS}	5	—	ns
CS7	MOSI Propagation Delay ($C_{LOAD} = 20$ pF)	t_{PDmosi}	-0.5	2.5	ns
CS8	MISO Setup Time	t_{Smiso}	8.5	—	ns
CS9	MISO Hold Time	t_{Hmiso}	0	—	ns
CS10	RDY to SSx Time ²	t_{SDRY}	5	—	ns

¹ See specific I/O AC parameters Section 4.5, "I/O AC Parameters"

² SPI_RDY is sampled internally by ipg_clk and is asynchronous to all other CSPI signals.

4.7.2.4 ECSPi Slave Mode Timing

Figure 33 depicts the timing of ECSPi in slave mode. Table 50 lists the ECSPi slave mode timing characteristics.

Table 50. ECSPi Slave Mode Timing Parameters

ID	Parameter	Symbol	Min	Max	Unit
CS1	SCLK Cycle Time—Read SCLK Cycle Time—Write	t_{clk}	15 40	—	ns
CS2	SCLK High or Low Time—Read SCLK High or Low Time—Write	t_{sw}	7 20	—	ns
CS4	SSx pulse width	t_{CSLH}	Half SCLK period	—	ns
CS5	SSx Lead Time (CS setup time)	t_{SCS}	5	—	ns
CS6	SSx Lag Time (CS hold time)	t_{HCS}	5	—	ns
CS7	MOSI Setup Time	t_{Smosi}	4	—	ns
CS8	MOSI Hold Time	t_{Hmosi}	4	—	ns
CS9	MISO Propagation Delay ($C_{LOAD} = 20$ pF)	t_{PDmiso}	4	17	ns

4.7.3 Enhanced Serial Audio Interface (ESAI) Timing Parameters

The ESAI consists of independent transmitter and receiver sections, each section with its own clock generator. Table 51 shows the interface timing values. The number field in the table refers to timing signals found in Figure 34 and Figure 35.

Table 51. Enhanced Serial Audio Interface (ESAI) Timing

No.	Characteristics ^{1,2,3}	Symbol	Expression ³	Min	Max	Condition ⁴	Unit
62	Clock cycle ⁵	t_{SSICC}	$4 \times T_C$ $4 \times T_C$	30.0 30.0	— —	i ck i ck	ns
63	Clock high period • For internal clock • For external clock	— —	$2 \times T_C - 9.0$ $2 \times T_C$	6 15	— —	— —	ns
64	Clock low period • For internal clock • For external clock	— —	$2 \times T_C - 9.0$ $2 \times T_C$	6 15	— —	— —	ns
65	SCKR rising edge to FSR out (bl) high	— —	— —	— —	17.0 7.0	x ck i ck a	ns
66	SCKR rising edge to FSR out (bl) low	— —	— —	— —	17.0 7.0	x ck i ck a	ns
67	SCKR rising edge to FSR out (wr) high ⁶	— —	— —	— —	19.0 9.0	x ck i ck a	ns
68	SCKR rising edge to FSR out (wr) low ⁶	— —	— —	— —	19.0 9.0	x ck i ck a	ns
69	SCKR rising edge to FSR out (wl) high	— —	— —	— —	16.0 6.0	x ck i ck a	ns
70	SCKR rising edge to FSR out (wl) low	— —	— —	— —	17.0 7.0	x ck i ck a	ns
71	Data in setup time before SCKR (SCK in synchronous mode) falling edge	— —	— —	12.0 19.0	— —	x ck i ck	ns
72	Data in hold time after SCKR falling edge	— —	— —	3.5 9.0	— —	x ck i ck	ns
73	FSR input (bl, wr) high before SCKR falling edge ⁶	— —	— —	2.0 12.0	— —	x ck i ck a	ns
74	FSR input (wl) high before SCKR falling edge	— —	— —	2.0 12.0	— —	x ck i ck a	ns
75	FSR input hold time after SCKR falling edge	— —	— —	2.5 8.5	— —	x ck i ck a	ns
78	SCKT rising edge to FST out (bl) high	— —	— —	— —	18.0 8.0	x ck i ck	ns
79	SCKT rising edge to FST out (bl) low	— —	— —	— —	20.0 10.0	x ck i ck	ns

Table 51. Enhanced Serial Audio Interface (ESAI) Timing (continued)

No.	Characteristics ^{1,2,3}	Symbol	Expression ³	Min	Max	Condition ⁴	Unit
80	SCKT rising edge to FST out (wr) high ⁶	— —	— —	— —	20.0 10.0	x ck i ck	ns
81	SCKT rising edge to FST out (wr) low ⁶	— —	— —	— —	22.0 12.0	x ck i ck	ns
82	SCKT rising edge to FST out (wl) high	— —	— —	— —	19.0 9.0	x ck i ck	ns
83	SCKT rising edge to FST out (wl) low	— —	— —	— —	20.0 10.0	x ck i ck	ns
84	SCKT rising edge to data out enable from high impedance	— —	— —	— —	22.0 17.0	x ck i ck	ns
86	SCKT rising edge to data out valid	— —	— —	— —	18.0 13.0	x ck i ck	ns
87	SCKT rising edge to data out high impedance ⁷⁷	— —	— —	— —	21.0 16.0	x ck i ck	ns
89	FST input (bl, wr) setup time before SCKT falling edge ⁶	— —	— —	2.0 18.0	— —	x ck i ck	ns
90	FST input (wl) setup time before SCKT falling edge	— —	— —	2.0 18.0	— —	x ck i ck	ns
91	FST input hold time after SCKT falling edge	— —	— —	4.0 5.0	— —	x ck i ck	ns
95	HCKR/HCKT clock cycle	—	$2 \times T_C$	15	—	—	ns
96	HCKT input rising edge to SCKT output	—	—	—	18.0	—	ns
97	HCKR input rising edge to SCKR output	—	—	—	18.0	—	ns

¹ V_{CORE_VDD} = 1.00 ± 0.10V
T_j = -40 °C to 125 °C
C_L = 50 pF

² i ck = internal clock
x ck = external clock
i ck a = internal clock, asynchronous mode
(asynchronous implies that SCKT and SCKR are two different clocks)
i ck s = internal clock, synchronous mode
(synchronous implies that SCKT and SCKR are the same clock)

³ bl = bit length
wl = word length
wr = word length relative

⁴ SCKT(SCKT pin) = transmit clock
SCKR(SCKR pin) = receive clock
FST(FST pin) = transmit frame sync
FSR(FSR pin) = receive frame sync
HCKT(HCKT pin) = transmit high frequency clock
HCKR(HCKR pin) = receive high frequency clock

⁵ For the internal clock, the external clock cycle is defined by l_{cyc} and the ESAI control register.

Electrical Characteristics

- ⁶ The word-relative frame sync signal waveform relative to the clock operates in the same manner as the bit-length frame sync signal waveform, but it spreads from one serial clock before the first bit clock (like the bit length frame sync signal), until the second-to-last bit clock of the first word in the frame.
- ⁷ Periodically sampled and not 100% tested.

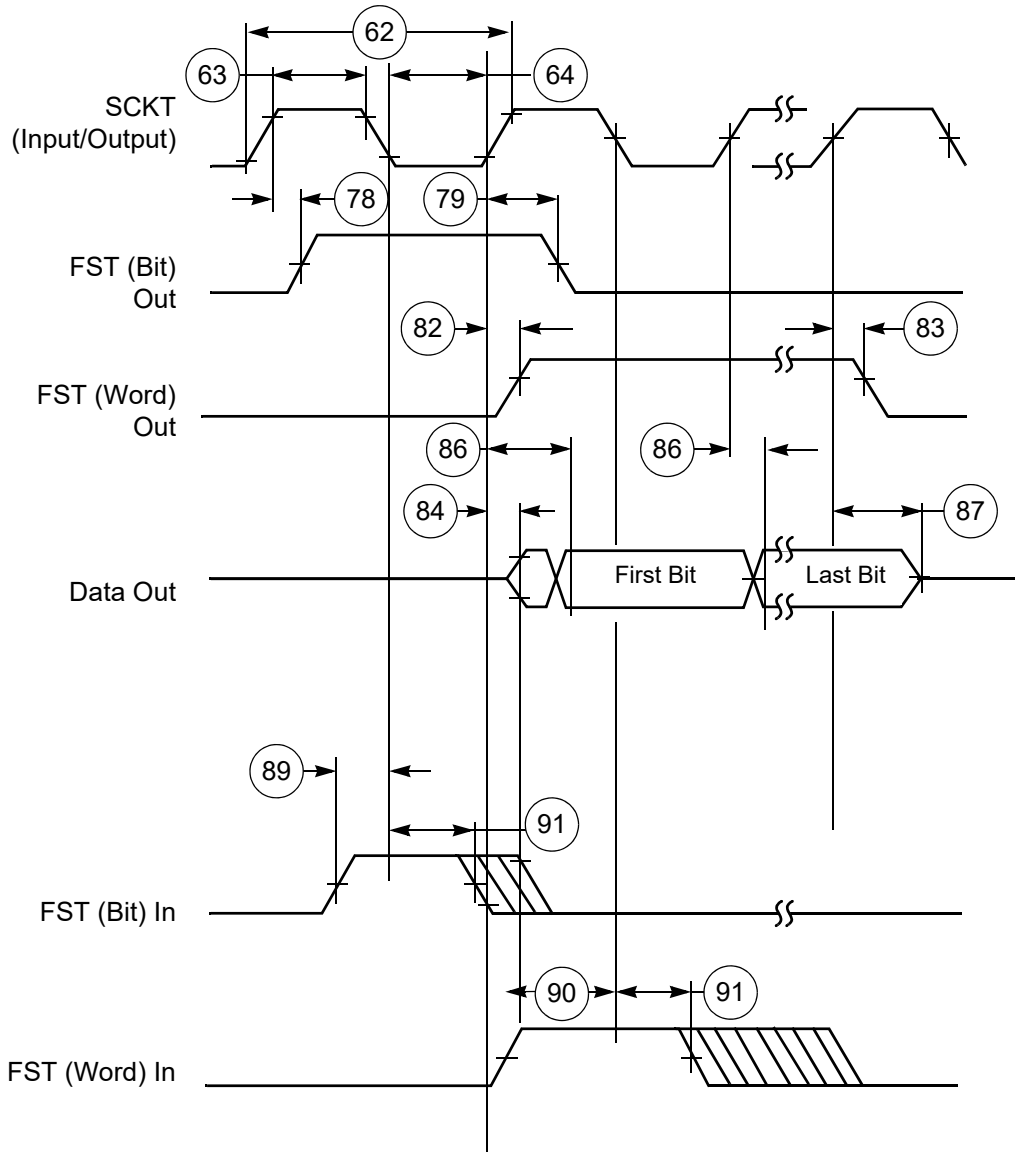

Figure 34. ESAI Transmitter Timing

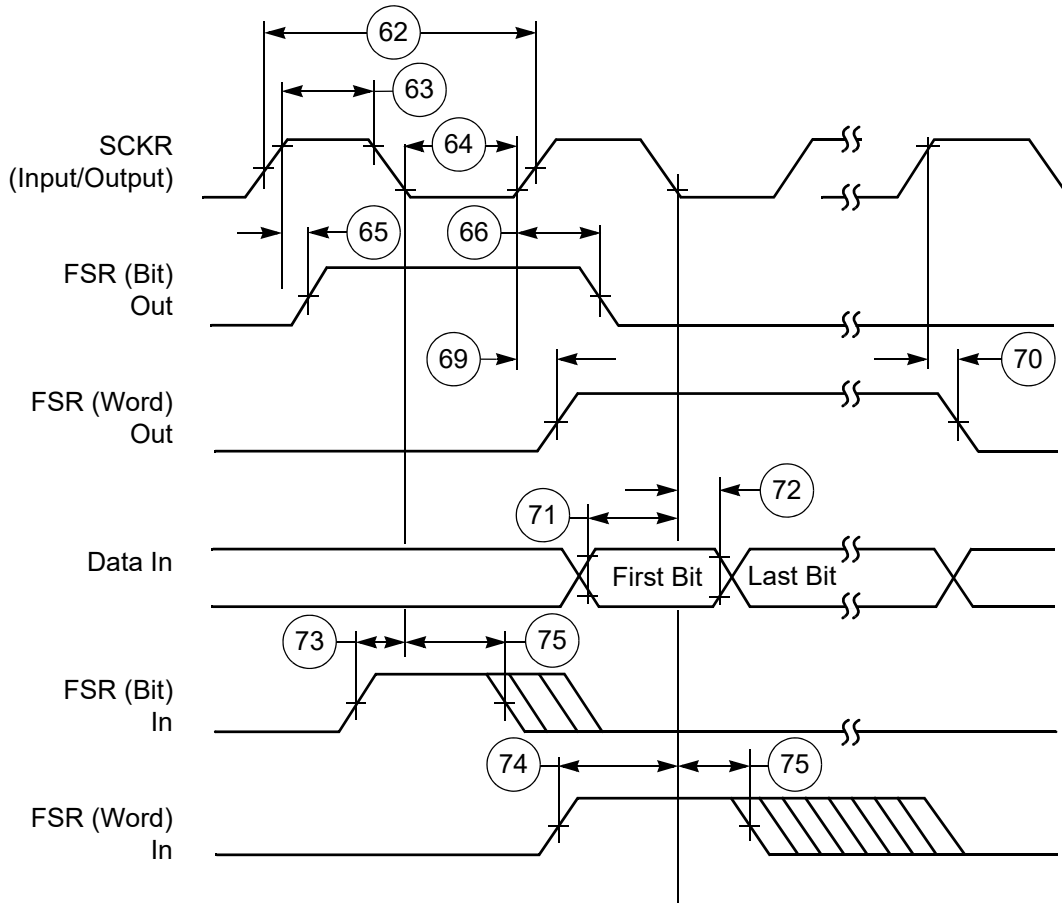

Figure 35. ESAI Receiver Timing

4.7.4 Enhanced Secured Digital Host Controller(eSDHCv2/v3) AC timing

This section describes the electrical information of the eSDHCv2/v3, which includes SD/eMMC4.3 (Single Data Rate) timing and eMMC4.4 (Dual Date Rate) timing.

4.7.4.1 SD/eMMC4.3 (Single Data Rate) AC Timing

Figure 36 depicts the timing of SD/eMMC4.3, and Table 52 lists the SD/eMMC4.3 timing characteristics.

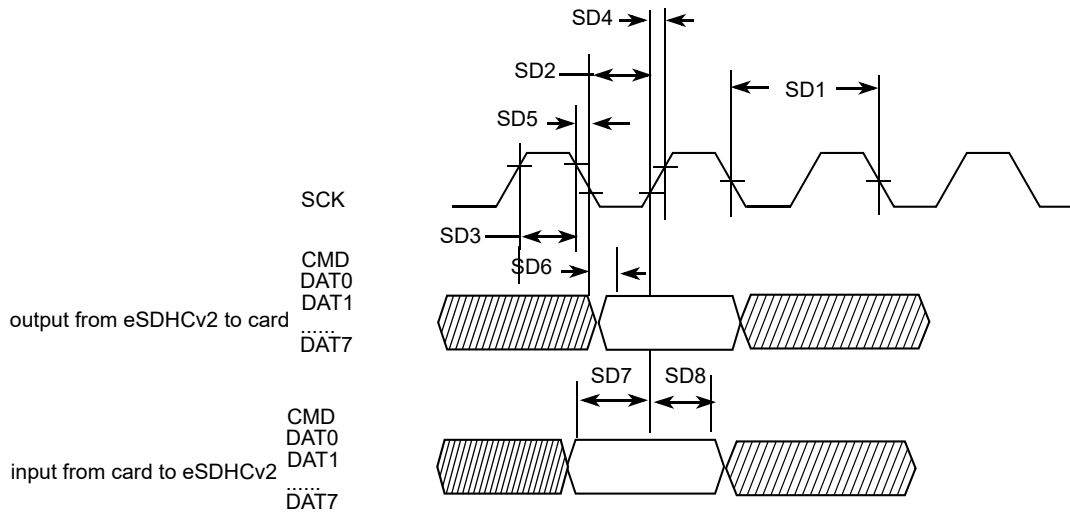

Figure 36. SD/eMMC4.3 Timing

Table 52. SD/eMMC4.3 Interface Timing Specification

ID	Parameter	Symbols	Min	Max	Unit
Card Input Clock					
SD1	Clock Frequency (Low Speed)	f_{PP}^1	0	400	kHz
	Clock Frequency (SD/SDIO Full Speed/High Speed)	f_{PP}^2	0	25/50	MHz
	Clock Frequency (MMC Full Speed/High Speed)	f_{PP}^3	0	20/52	MHz
	Clock Frequency (Identification Mode)	f_{OD}	100	400	kHz
SD2	Clock Low Time	t_{WL}	7	—	ns
SD3	Clock High Time	t_{WH}	7	—	ns
SD4	Clock Rise Time	t_{TLH}	—	3	ns
SD5	Clock Fall Time	t_{THL}	—	3	ns
eSDHC Output/Card Inputs CMD, DAT (Reference to CLK)					
SD6	eSDHCv2 Output Delay (port 1, 2, and 4)	t_{OD}	-3.5	3.5	ns
	eSDHCv3 Output Delay (port 3)	t_{OD}	-4.5	4.5	ns

Table 52. SD/eMMC4.3 Interface Timing Specification (continued)

ID	Parameter	Symbols	Min	Max	Unit
eSDHC Input/Card Outputs CMD, DAT (Reference to CLK)					
SD7	eSDHC Input Setup Time	t_{ISU}	2.5	—	ns
SD8	eSDHC Input Hold Time ⁴	t_{IH}	2.5	—	ns

¹ In low speed mode, card clock must be lower than 400 kHz, voltage ranges from 2.7 to 3.6 V.

² In normal (full) speed mode for SD/SDIO card, clock frequency can be any value between 0–25 MHz. In high-speed mode, clock frequency can be any value between 0–50 MHz.

³ In normal (full) speed mode for MMC card, clock frequency can be any value between 0–20 MHz. In high-speed mode, clock frequency can be any value between 0–52 MHz.

⁴To satisfy hold timing, the delay difference between clock input and cmd/data input must not exceed 2 ns.

4.7.4.2 eMMC4.4 (Dual Data Rate) eSDHCv3 AC Timing

Figure 37 depicts the timing of eMMC4.4. Table 53 lists the eMMC4.4 timing characteristics. Be aware that only DATA is sampled on both edges of the clock (not applicable to CMD).

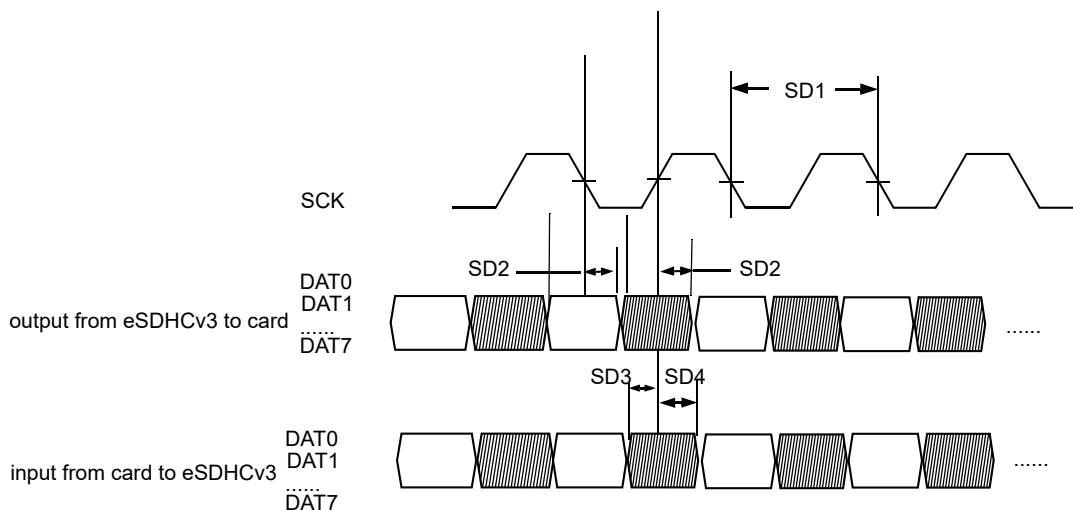

Figure 37. eMMC4.4 Timing

Table 53. eMMC4.4 Interface Timing Specification

ID	Parameter	Symbols	Min	Max	Unit
Card Input Clock					
SD1	Clock Frequency (MMC Full Speed/High Speed)	f_{PP}	0	52	MHz
eSDHC Output / Card Inputs CMD, DAT (Reference to CLK)					
SD2	eSDHC Output Delay	t_{OD}	-4.5	4.5	ns

Table 53. eMMC4.4 Interface Timing Specification (continued)

ID	Parameter	Symbols	Min	Max	Unit
eSDHC Input / Card Outputs CMD, DAT (Reference to CLK)					
SD3	eSDHC Input Setup Time	t_{ISU}	2.5	—	ns
SD4	eSDHC Input Hold Time	t_{IH}	2.5	—	ns

4.7.5 FEC AC Timing Parameters

This section describes the electrical information of the Fast Ethernet Controller (FEC) module. The FEC is designed to support both 10 and 100 Mbps Ethernet/IEEE 802.3 networks. An external transceiver interface and transceiver function are required to complete the interface to the media. The FEC supports the 10/100 Mbps MII (18 pins in total) and the 10 Mbps (only 7-wire interface, which uses 7 of the MII pins), for connection to an external Ethernet transceiver. For the pin list of MII and 7-wire, see the i.MX53 Reference Manual.

This section describes the AC timing specifications of the FEC. The MII signals are compatible with transceivers operating at a voltage of 3.3 V.

4.7.5.1 MII Receive Signal Timing

The MII receive signal timing involves the FEC_RXD[3:0], FEC_RX_DV, FEC_RX_ER, and FEC_RX_CLK signals. The receiver functions correctly up to a FEC_RX_CLK maximum frequency of 25 MHz + 1%. There is no minimum frequency requirement but the processor clock frequency must exceed twice the FEC_RX_CLK frequency. Table 54 lists the MII receive channel signal timing parameters and Figure 38 shows MII receive signal timings.

Table 54. MII Receive Signal Timing

No.	Characteristics ^{1 2}	Min	Max	Unit
M1	FEC_RXD[3:0], FEC_RX_DV, FEC_RX_ER to FEC_RX_CLK setup	5	—	ns
M2	FEC_RX_CLK to FEC_RXD[3:0], FEC_RX_DV, FEC_RX_ER hold	5	—	ns
M3	FEC_RX_CLK pulse width high	35%	65%	FEC_RX_CLK period
M4	FEC_RX_CLK pulse width low	35%	65%	FEC_RX_CLK period

¹ FEC_RX_DV, FEC_RX_CLK, and FEC_RXD0 have same timing in 10 Mbps 7-wire interface mode.

² Test conditions: 25pF on each output signal.

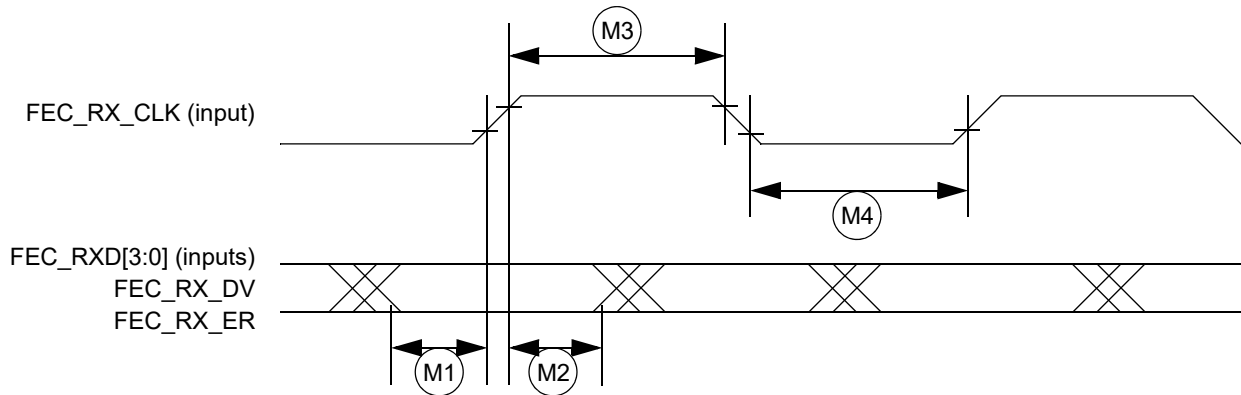

Figure 38. MII Receive Signal Timing Diagram

4.7.5.2 MII Transmit Signal Timing

The MII transmit signal timing affects the FEC_TXD[3:0], FEC_TX_EN, FEC_TX_ER, and FEC_TX_CLK signals. The transmitter functions correctly up to a FEC_TX_CLK maximum frequency of 25 MHz + 1%. There is no minimum frequency requirement. In addition, the processor clock frequency must exceed twice the FEC_TX_CLK frequency.

Table 55 lists MII transmit channel timing parameters. Figure 39 shows MII transmit signal timing diagram for the values listed in Table 55.

Table 55. MII Transmit Signal Timing

Num	Characteristic ^{1 2}	Min	Max	Unit
M5	FEC_TX_CLK to FEC_TXD[3:0], FEC_TX_EN, FEC_TX_ER invalid	5	—	ns
M6	FEC_TX_CLK to FEC_TXD[3:0], FEC_TX_EN, FEC_TX_ER valid	—	20	ns
M7	FEC_TX_CLK pulse width high	35%	65%	FEC_TX_CLK period
M8	FEC_TX_CLK pulse width low	35%	65%	FEC_TX_CLK period

¹ FEC_TX_EN, FEC_TX_CLK, and FEC_TXD0 have the same timing in 10 Mbps 7-wire interface mode.

² Test conditions: 25pF on each output signal.

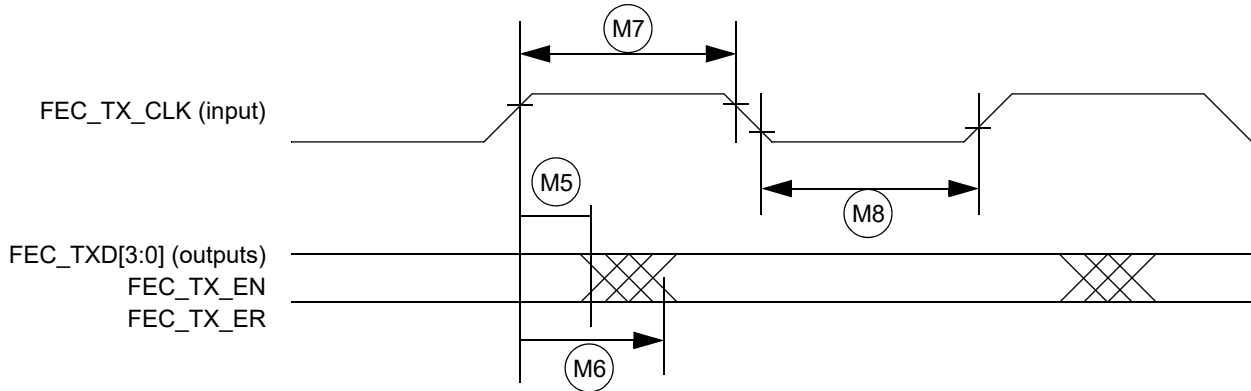

Figure 39. MII Transmit Signal Timing Diagram

4.7.5.3 MII Async Inputs Signal Timing (FEC_CRIS and FEC_COL)

Table 56 lists MII asynchronous inputs signal timing information. Figure 40 shows MII asynchronous input timings listed in Table 56.

Table 56. MII Async Inputs Signal Timing

Num	Characteristic ¹	Min	Max	Unit
M9 ²	FEC_CRIS to FEC_COL minimum pulse width	1.5	—	FEC_TX_CLK period

¹ Test conditions: 25pF on each output signal.

² FEC_COL has the same timing in 10 Mbit 7-wire interface mode.

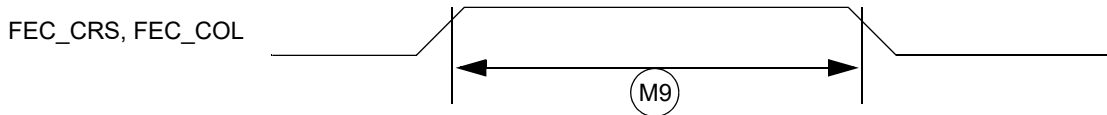

Figure 40. MII Async Inputs Timing Diagram

4.7.5.4 MII Serial Management Channel Timing (FEC_MDIO and FEC_MDC)

Table 57 lists MII serial management channel timings. Figure 41 shows MII serial management channel timings listed in Table 57. The MDC frequency should be equal to or less than 2.5 MHz to be compliant with the IEEE 802.3 MII specification. However, the FEC can function correctly with a maximum MDC frequency of 15 MHz.

Table 57. MII Transmit Signal Timing

ID	Characteristics ¹	Min	Max	Unit
M10	FEC_MDC falling edge to FEC_MDIO output invalid (minimum propagation delay)	0	—	ns
M11	FEC_MDC falling edge to FEC_MDIO output valid (max propagation delay)	—	5	ns
M12	FEC_MDIO (input) to FEC_MDC rising edge setup	18	—	ns

Table 57. MII Transmit Signal Timing (continued)

ID	Characteristics ¹	Min	Max	Unit
M13	FEC_MDIO (input) to FEC_MDC rising edge hold	0	—	ns
M14	FEC_MDC pulse width high	40 %	60%	FEC_MDC period
M15	FEC_MDC pulse width low	40 %	60%	FEC_MDC period

¹ Test conditions: 25pF on each output signal.

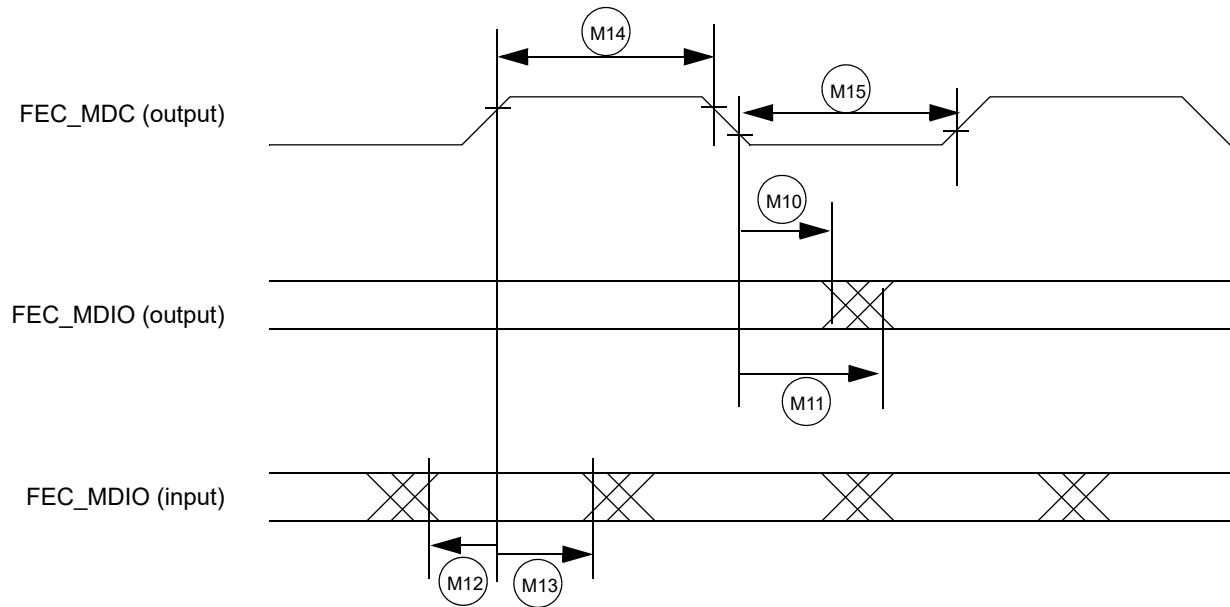

Figure 41. MII Serial Management Channel Timing Diagram

4.7.5.5 RMII Mode Timing

In RMII mode, FEC_TX_CLK is used as the REF_CLK which is a 50 MHz \pm 50 ppm continuous reference clock. FEC_RX_DV is used as the CRS_DV in RMII, and other signals under RMII mode include FEC_TX_EN, FEC_TXD[1:0], FEC_RXD[1:0] and optional FEC_RX_ER.

The RMII mode timings are shown in Table 58 and Figure 42.

Table 58. RMII Signal Timing

No.	Characteristics ¹	Min	Max	Unit
M16	REF_CLK(FEC_TX_CLK) pulse width high	35%	65%	REF_CLK period
M17	REF_CLK(FEC_TX_CLK) pulse width low	35%	65%	REF_CLK period
M18	REF_CLK to FEC_TXD[1:0], FEC_TX_EN invalid	2	—	ns
M19	REF_CLK to FEC_TXD[1:0], FEC_TX_EN valid	—	16	ns

Table 58. RMII Signal Timing (continued)

No.	Characteristics ¹	Min	Max	Unit
M20	FEC_RXD[1:0], CRS_DV(FEC_RX_DV), FEC_RX_ER to REF_CLK setup	4	—	ns
M21	REF_CLK to FEC_RXD[1:0], FEC_RX_DV, FEC_RX_ER hold	2	—	ns

¹ Test conditions: 25pF on each output signal.

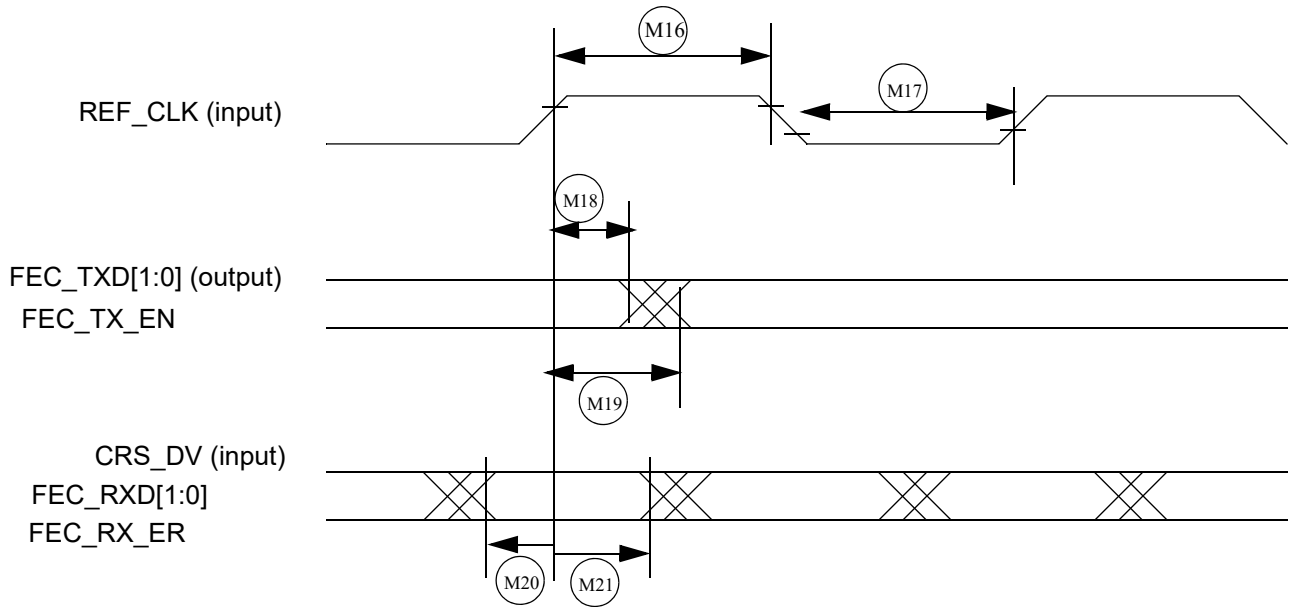

Figure 42. RMII Mode Signal Timing Diagram

4.7.6 Flexible Controller Area Network (FLEXCAN) AC Electrical Specifications

The electrical characteristics are related to the CAN transceiver external to i.MX53 such as MC33902 from Freescale. The i.MX53 has two CAN modules available for systems design. Tx and Rx ports for both modules are multiplexed with other I/O pins. See the IOMUXC chapter of the i.MX53 Reference Manual to see which pins expose Tx and Rx pins; these ports are named TXCAN and RXCAN, respectively.

4.7.7 I²C Module Timing Parameters

This section describes the timing parameters of the I²C module. Figure 43 depicts the timing of I²C module, and Table 59 lists the I²C module timing characteristics.

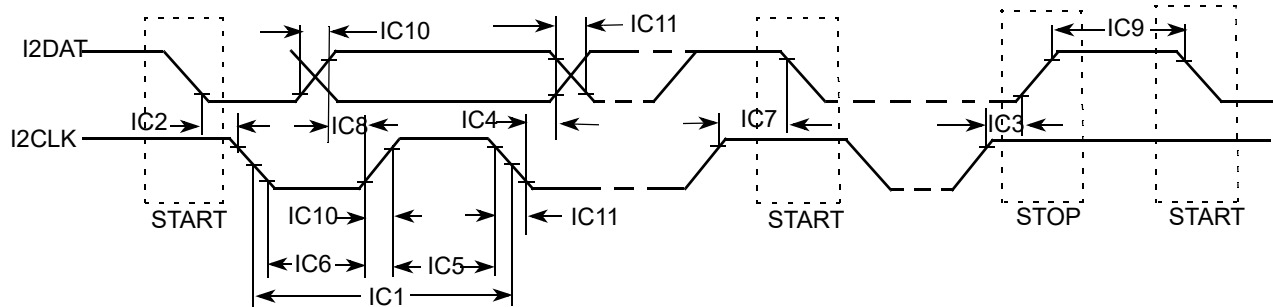

Figure 43. I²C Bus Timing

Table 59. I²C Module Timing Parameters

ID	Parameter	Standard Mode Supply Voltage = 1.65 V–1.95 V, 2.7 V–3.3 V		Fast Mode Supply Voltage = 2.7 V–3.3 V		Unit
		Min	Max	Min	Max	
IC1	I2CLK cycle time	10	—	2.5	—	μs
IC2	Hold time (repeated) START condition	4.0	—	0.6	—	μs
IC3	Set-up time for STOP condition	4.0	—	0.6	—	μs
IC4	Data hold time	0 ¹	3.45 ²	0 ¹	0.9 ²	μs
IC5	HIGH Period of I2CLK Clock	4.0	—	0.6	—	μs
IC6	LOW Period of the I2CLK Clock	4.7	—	1.3	—	μs
IC7	Set-up time for a repeated START condition	4.7	—	0.6	—	μs
IC8	Data set-up time	250	—	100 ³	—	ns
IC9	Bus free time between a STOP and START condition	4.7	—	1.3	—	μs
IC10	Rise time of both I2DAT and I2CLK signals	—	1000	20 + 0.1C _b ⁴	300	ns
IC11	Fall time of both I2DAT and I2CLK signals	—	300	20 + 0.1C _b ⁴	300	ns
IC12	Capacitive load for each bus line (C _b)	—	400	—	400	pF

¹ A device must internally provide a hold time of at least 300 ns for I2DAT signal in order to bridge the undefined region of the falling edge of I2CLK.

² The maximum hold time has only to be met if the device does not stretch the LOW period (ID no IC5) of the I2CLK signal.

³ A Fast-mode I2C-bus device can be used in a Standard-mode I2C-bus system, but the requirement of Set-up time (ID No IC7) of 250 ns must be met. This automatically is the case if the device does not stretch the LOW period of the I2CLK signal. If such a device does stretch the LOW period of the I2CLK signal, it must output the next data bit to the I2DAT line $\text{max_rise_time (IC9)} + \text{data_setup_time (IC7)} = 1000 + 250 = 1250$ ns (according to the Standard-mode I2C-bus specification) before the I2CLK line is released.

⁴ C_b = total capacitance of one bus line in pF.

4.7.8 Image Processing Unit (IPU) Module Parameters

The purpose of the IPU is to provide comprehensive support for the flow of data from an image sensor and/or to a display device. This support covers all aspects of these activities:

- Connectivity to relevant devices—cameras, displays, graphics accelerators, and TV encoders.
- Related image processing and manipulation: sensor image signal processing, display processing, image conversions, and other related functions.
- Synchronization and control capabilities, such as avoidance of tearing artifacts.

4.7.8.1 IPU Sensor Interface Signal Mapping

The IPU supports a number of sensor input formats. [Table 60](#) defines the mapping of the Sensor Interface Pins used for various supported interface formats.

Table 60. Camera Input Signal Cross Reference, Format and Bits Per Cycle

Signal Name ¹	RGB565 8 bits 2 cycles	RGB565 ² 8 bits 3 cycles	RGB666 ³ 8 bits 3 cycles	RGB888 8 bits 3 cycles	YCbCr ⁴ 8 bits 2 cycles	RGB565 ⁵ 16 bits 2 cycles	YCbCr ⁶ 16 bits 1 cycle	YCbCr ⁷ 16 bits 1 cycle	YCbCr ⁸ 20 bits 1 cycle
CSIx_DAT0	—	—	—	—	—	—	—	0	C[0]
CSIx_DAT1	—	—	—	—	—	—	—	0	C[1]
CSIx_DAT2	—	—	—	—	—	—	—	C[0]	C[2]
CSIx_DAT3	—	—	—	—	—	—	—	C[1]	C[3]
CSIx_DAT4	—	—	—	—	—	B[0]	C[0]	C[2]	C[4]
CSIx_DAT5	—	—	—	—	—	B[1]	C[1]	C[3]	C[5]
CSIx_DAT6	—	—	—	—	—	B[2]	C[2]	C[4]	C[6]
CSIx_DAT7	—	—	—	—	—	B[3]	C[3]	C[5]	C[7]
CSIx_DAT8	—	—	—	—	—	B[4]	C[4]	C[6]	C[8]
CSIx_DAT9	—	—	—	—	—	G[0]	C[5]	C[7]	C[9]
CSIx_DAT10	—	—	—	—	—	G[1]	C[6]	0	Y[0]
CSIx_DAT11	—	—	—	—	—	G[2]	C[7]	0	Y[1]
CSIx_DAT12	B[0], G[3]	R[2],G[4],B[2]	R/G/B[4]	R/G/B[0]	Y/C[0]	G[3]	Y[0]	Y[0]	Y[2]
CSIx_DAT13	B[1], G[4]	R[3],G[5],B[3]	R/G/B[5]	R/G/B[1]	Y/C[1]	G[4]	Y[1]	Y[1]	Y[3]
CSIx_DAT14	B[2], G[5]	R[4],G[0],B[4]	R/G/B[0]	R/G/B[2]	Y/C[2]	G[5]	Y[2]	Y[2]	Y[4]
CSIx_DAT15	B[3], R[0]	R[0],G[1],B[0]	R/G/B[1]	R/G/B[3]	Y/C[3]	R[0]	Y[3]	Y[3]	Y[5]
CSIx_DAT16	B[4], R[1]	R[1],G[2],B[1]	R/G/B[2]	R/G/B[4]	Y/C[4]	R[1]	Y[4]	Y[4]	Y[6]
CSIx_DAT17	G[0], R[2]	R[2],G[3],B[2]	R/G/B[3]	R/G/B[5]	Y/C[5]	R[2]	Y[5]	Y[5]	Y[7]
CSIx_DAT18	G[1], R[3]	R[3],G[4],B[3]	R/G/B[4]	R/G/B[6]	Y/C[6]	R[3]	Y[6]	Y[6]	Y[8]
CSIx_DAT19	G[2], R[4]	R[4],G[5],B[4]	R/G/B[5]	R/G/B[7]	Y/C[7]	R[4]	Y[7]	Y[7]	Y[9]

¹ CSIx stands for CSI1 or CSI2.

- 2 The MSB bits are duplicated on LSB bits implementing color extension.
- 3 The two MSB bits are duplicated on LSB bits implementing color extension.
- 4 YCbCr 8 bits—Supported within the BT.656 protocol (sync embedded within the data stream).
- 5 RGB 16 bits—Supported in two ways: (1) As a “generic data” input, with no on-the-fly processing; (2) With on-the-fly processing, but only under some restrictions on the control protocol.
- 6 YCbCr 16 bits—Supported as a “generic data” input, with no on-the-fly processing.
- 7 YCbCr 16 bits—Supported as a sub-case of the YCbCr, 20 bits, under the same conditions (BT.1120 protocol).
- 8 YCbCr 20 bits—Supported only within the BT.1120 protocol (syncs embedded within the data stream).

4.7.8.2 Sensor Interface Timings

There are three camera timing modes supported by the IPU.

4.7.8.2.1 BT.656 and BT.1120 Video Mode

Smart camera sensors, which include imaging processing, usually support video mode transfer. They use an embedded timing syntax to replace the SENSB_VSYNC and SENSB_HSYNC signals. The timing syntax is defined by the BT.656/BT.1120 standards.

This operation mode follows the recommendations of ITU BT.656/ ITU BT.1120 specifications. The only control signal used is SENSB_PIX_CLK. Start-of-frame and active-line signals are embedded in the data stream. An active line starts with a SAV code and ends with a EAV code. In some cases, digital blanking is inserted in between EAV and SAV code. The CSI decodes and filters out the timing-coding from the data stream, thus recovering SENSB_VSYNC and SENSB_HSYNC signals for internal use. On BT.656 one component per cycle is received over the SENSB_DATA bus. On BT.1120 two components per cycle are received over the SENSB_DATA bus.

4.7.8.2.2 Gated Clock Mode

The SENSB_VSYNC, SENSB_HSYNC, and SENSB_PIX_CLK signals are used in this mode. See [Figure 44](#).

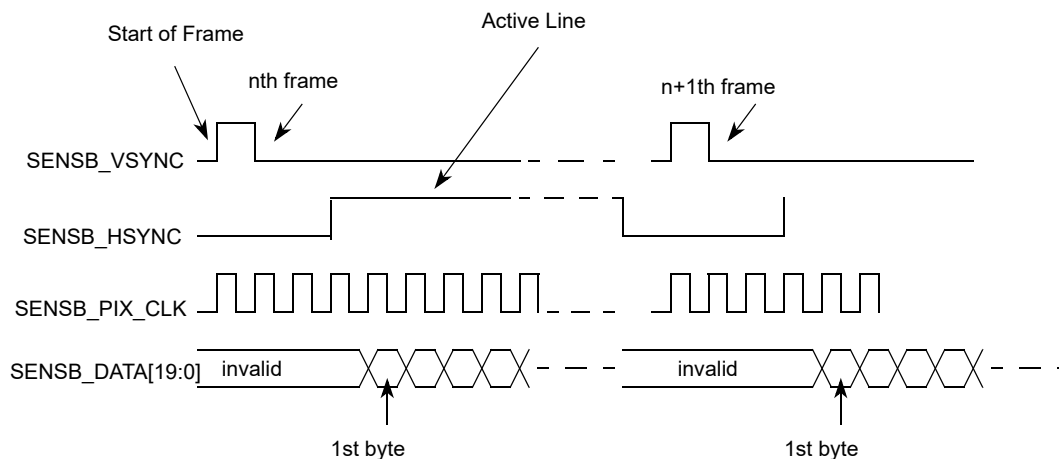

Figure 44. Gated Clock Mode Timing Diagram

A frame starts with a rising edge on SENSB_VSYNC (all the timings correspond to straight polarity of the corresponding signals). Then SENSB_HSYNC goes to high and hold for the entire line. Pixel clock is

Electrical Characteristics

valid as long as SENS_B_HSYNC is high. Data is latched at the rising edge of the valid pixel clocks. SENS_B_HSYNC goes to low at the end of line. Pixel clocks then become invalid and the CSI stops receiving data from the stream. For next line the SENS_B_HSYNC timing repeats. For next frame the SENS_B_VSYNC timing repeats.

4.7.8.2.3 Non-Gated Clock Mode

The timing is the same as the gated-clock mode (described in Section 4.7.8.2.2, “Gated Clock Mode,”) except for the SENS_B_HSYNC signal, which is not used (see Figure 45). All incoming pixel clocks are valid and cause data to be latched into the input FIFO. The SENS_B_PIX_CLK signal is inactive (states low) until valid data is going to be transmitted over the bus.

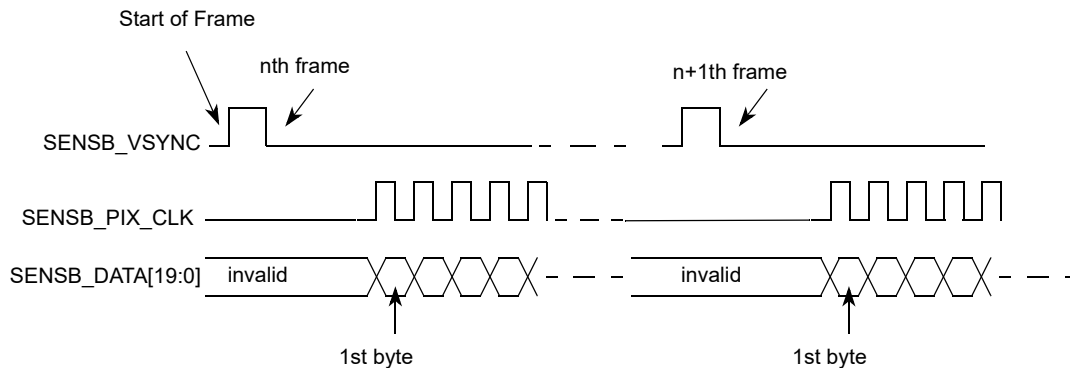

Figure 45. Non-Gated Clock Mode Timing Diagram

The timing described in Figure 45 is that of a typical sensor. Some other sensors may have a slightly different timing. The CSI can be programmed to support rising/falling-edge triggered SENS_B_VSYNC; active-high/low SENS_B_HSYNC; and rising/falling-edge triggered SENS_B_PIX_CLK.

4.7.8.3 Electrical Characteristics

Figure 46 depicts the sensor interface timing. SENS_B_MCLK signal described here is not generated by the IPU. Table 61 lists the sensor interface timing characteristics.

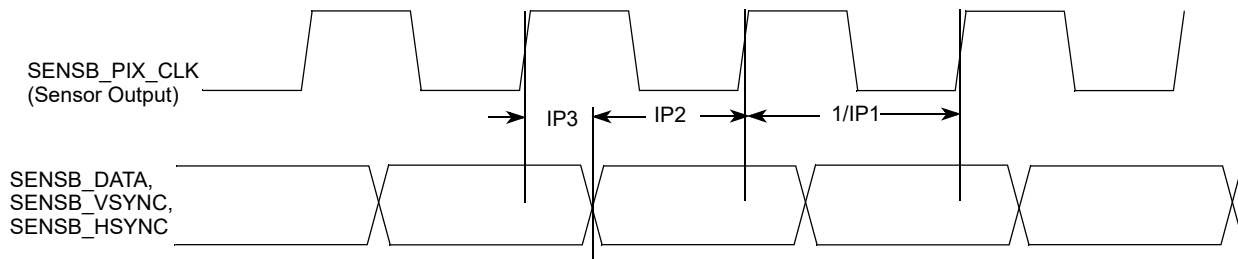

Figure 46. Sensor Interface Timing Diagram

Table 61. Sensor Interface Timing Characteristics

ID	Parameter	Symbol	Min	Max	Unit
IP1	Sensor output (pixel) clock frequency	Fpck	0.01	180	MHz
IP2	Data and control setup time	Tsu	2	—	ns
IP3	Data and control holdup time	Thd	1	—	ns

4.7.8.4 IPU Display Interface Signal Mapping

The IPU supports a number of display output video formats. [Table 62](#) defines the mapping of the Display Interface Pins used during various supported video interface formats.

Table 62. Video Signal Cross-Reference

i.MX53	LCD								Comment ¹
Port Name (x=0, 1)	RGB, Signal Name (General)	RGB/TV Signal Allocation (Example)						Smart	
		16-bit RGB	18-bit RGB	24 Bit RGB	8-bit YCrCb ²	16-bit YCrCb	20-bit YCrCb	Signal Name	
DISPx_DAT0	DAT[0]	B[0]	B[0]	B[0]	Y/C[0]	C[0]	C[0]	DAT[0]	The restrictions are as follows: a) There are maximal three continuous groups of bits that could be independently mapped to the external bus. Groups should not be overlapped. b) The bit order is expressed in each of the bit groups, for example B[0] = least significant blue pixel bit
DISPx_DAT1	DAT[1]	B[1]	B[1]	B[1]	Y/C[1]	C[1]	C[1]	DAT[1]	
DISPx_DAT2	DAT[2]	B[2]	B[2]	B[2]	Y/C[2]	C[2]	C[2]	DAT[2]	
DISPx_DAT3	DAT[3]	B[3]	B[3]	B[3]	Y/C[3]	C[3]	C[3]	DAT[3]	
DISPx_DAT4	DAT[4]	B[4]	B[4]	B[4]	Y/C[4]	C[4]	C[4]	DAT[4]	
DISPx_DAT5	DAT[5]	G[0]	B[5]	B[5]	Y/C[5]	C[5]	C[5]	DAT[5]	
DISPx_DAT6	DAT[6]	G[1]	G[0]	B[6]	Y/C[6]	C[6]	C[6]	DAT[6]	
DISPx_DAT7	DAT[7]	G[2]	G[1]	B[7]	Y/C[7]	C[7]	C[7]	DAT[7]	
DISPx_DAT8	DAT[8]	G[3]	G[2]	G[0]	—	Y[0]	C[8]	DAT[8]	
DISPx_DAT9	DAT[9]	G[4]	G[3]	G[1]	—	Y[1]	C[9]	DAT[9]	
DISPx_DAT10	DAT[10]	G[5]	G[4]	G[2]	—	Y[2]	Y[0]	DAT[10]	
DISPx_DAT11	DAT[11]	R[0]	G[5]	G[3]	—	Y[3]	Y[1]	DAT[11]	
DISPx_DAT12	DAT[12]	R[1]	R[0]	G[4]	—	Y[4]	Y[2]	DAT[12]	
DISPx_DAT13	DAT[13]	R[2]	R[1]	G[5]	—	Y[5]	Y[3]	DAT[13]	
DISPx_DAT14	DAT[14]	R[3]	R[2]	G[6]	—	Y[6]	Y[4]	DAT[14]	
DISPx_DAT15	DAT[15]	R[4]	R[3]	G[7]	—	Y[7]	Y[5]	DAT[15]	
DISPx_DAT16	DAT[16]	—	R[4]	R[0]	—	—	Y[6]	—	
DISPx_DAT17	DAT[17]	—	R[5]	R[1]	—	—	Y[7]	—	
DISPx_DAT18	DAT[18]	—	—	R[2]	—	—	Y[8]	—	
DISPx_DAT19	DAT[19]	—	—	R[3]	—	—	Y[9]	—	
DISPx_DAT20	DAT[20]	—	—	R[4]	—	—	—	—	
DISPx_DAT21	DAT[21]	—	—	R[5]	—	—	—	—	

Table 62. Video Signal Cross-Reference (continued)

i.MX53	LCD								Comment ¹
Port Name (x=0, 1)	RGB, Signal Name (General)	RGB/TV Signal Allocation (Example)						Smart	
		16-bit RGB	18-bit RGB	24 Bit RGB	8-bit YCrCb ²	16-bit YCrCb	20-bit YCrCb	Signal Name	
DISPx_DAT22	DAT[22]	—	—	R[6]	—	—	—	—	—
DISPx_DAT23	DAT[23]	—	—	R[7]	—	—	—	—	—
Dlx_DISP_CLK	PixCLK							—	—
Dlx_PIN1	—							VSYNC_IN	May be required for anti-tearing
Dlx_PIN2	HSYNC							—	—
Dlx_PIN3	VSYNC							—	VSYNC out
Dlx_PIN4	—							—	Additional frame/row synchronous signals with programmable timing
Dlx_PIN5	—							—	
Dlx_PIN6	—							—	
Dlx_PIN7	—							—	
Dlx_PIN8	—							—	
Dlx_D0_CS	—							CS0	—
Dlx_D1_CS	—							CS1	Alternate mode of PWM output for contrast or brightness control
Dlx_PIN11	—							WR	—
Dlx_PIN12	—							RD	—
Dlx_PIN13	—							RS1	Register select signal
Dlx_PIN14	—							RS2	Optional RS2
Dlx_PIN15	DRDY/DV							DRDY	Data validation/blank, data enable
Dlx_PIN16	—							—	Additional data synchronous signals with programmable features/timing
Dlx_PIN17	Q							—	

¹ Signal mapping (both data and control/synchronization) is flexible. The table provides examples.

² This mode works in compliance with recommendation ITU-R BT.656. The timing reference signals (frame start, frame end, line start, and line end) are embedded in the 8-bit data bus. Only video data is supported, transmission of non-video related data during blanking intervals is not supported.

NOTE

Table 62 provides information for both the Disp0 and Disp1 ports. However, Disp1 port has reduced pinout depending on IOMUXC configuration and therefore may not support all the above configurations. See the IOMUXC table for details.

4.7.8.5 IPU Display Interface Timing

The IPU Display Interface supports two kinds of display accesses: synchronous and asynchronous. There are two groups of external interface pins to provide synchronous and asynchronous controls accordantly.

4.7.8.5.1 Synchronous Controls

The synchronous control changes its value as a function of a system or of an external clock. This control has a permanent period and a permanent wave form.

There are special physical outputs to provide synchronous controls:

- The `ipp_disp_clk` is a dedicated base synchronous signal that is used to generate a base display (component, pixel) clock for a display.
- The `ipp_pin_1–ipp_pin_7` are general purpose synchronous pins, that can be used to provide HSYNC, VSYNC, DRDY or any else independent signal to a display.

The IPU has a system of internal binding counters for internal events (such as HSYNC/VSYCN and so on) calculation. The internal event (local start point) is synchronized with internal `DI_CLK`. A suitable control starts from the local start point with predefined UP and DOWN values to calculate control's changing points with half `DI_CLK` resolution. A full description of the counters system can be found in the IPU chapter of the i.MX53 Reference Manual.

4.7.8.5.2 Asynchronous Controls

The asynchronous control is a data-oriented signal that changes its value with an output data according to additional internal flags coming with the data.

There are special physical outputs to provide asynchronous controls, as follows:

- The `ipp_d0_cs` and `ipp_d1_cs` pins are dedicated to provide chip select signals to two displays.
- The `ipp_pin_11–ipp_pin_17` are general purpose asynchronous pins, that can be used to provide WR, RD, RS or any other data oriented signal to display.

NOTE

The IPU has independent signal generators for asynchronous signals toggling. When a DI decides to put a new asynchronous data in the bus, a new internal start (local start point) is generated. The signals generators calculate predefined UP and DOWN values to change pins states with half `DI_CLK` resolution.

4.7.8.6 Synchronous Interfaces to Standard Active Matrix TFT LCD Panels

4.7.8.6.1 IPU Display Operating Signals

The IPU uses four control signals and data to operate a standard synchronous interface:

- IPP_DISP_CLK—Clock to display
- HSYNC—Horizontal synchronization
- VSYNC—Vertical synchronization
- DRDY—Active data

All synchronous display controls are generated on the base of an internally generated “local start point”. The synchronous display controls can be placed on time axis with DI’s offset, up and down parameters. The display access can be whole number of DI clock (Tdiclk) only. The IPP_DATA can not be moved relative to the local start point. The data bus of the synchronous interface is output direction only.

4.7.8.6.2 LCD Interface Functional Description

Figure 47 depicts the LCD interface timing for a generic active matrix color TFT panel. In this figure signals are shown with negative polarity. The sequence of events for active matrix interface timing is:

- DI_CLK internal DI clock, used for calculation of other controls.
- IPP_DISP_CLK latches data into the panel on its negative edge (when positive polarity is selected). In active mode, IPP_DISP_CLK runs continuously.
- HSYNC causes the panel to start a new line. (Usually IPP_PIN_2 is used as HSYNC.)
- VSYNC causes the panel to start a new frame. It always encompasses at least one HSYNC pulse. (Usually IPP_PIN_3 is used as VSYNC.)
- DRDY acts like an output enable signal to the CRT display. This output enables the data to be shifted onto the display. When disabled, the data is invalid and the trace is off. (DRDY can be used either synchronous or asynchronous generic purpose pin as well.)

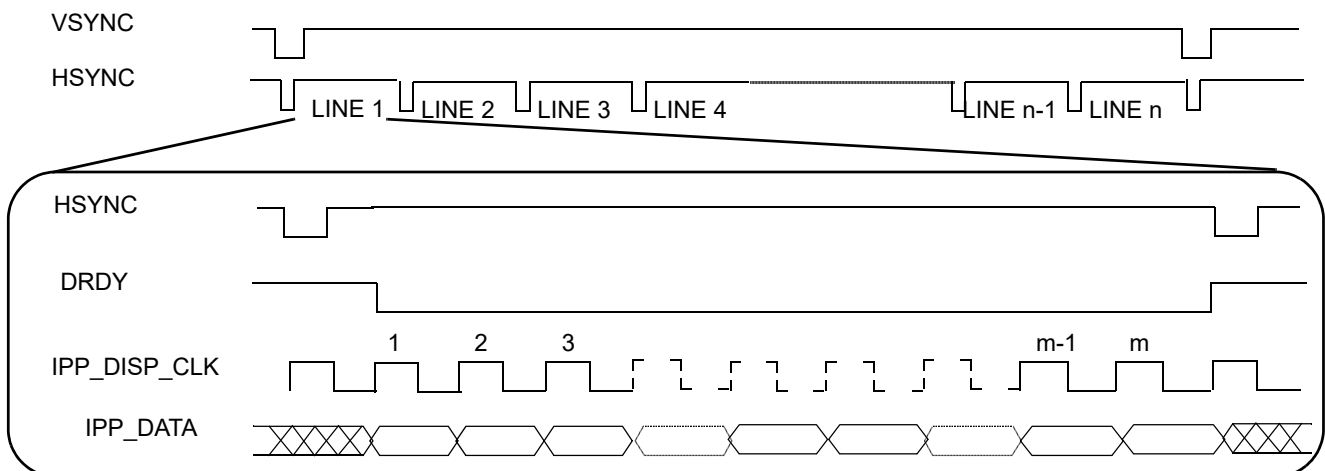

Figure 47. Interface Timing Diagram for TFT (Active Matrix) Panels

4.7.8.6.3 TFT Panel Sync Pulse Timing Diagrams

Figure 48 depicts the horizontal timing (timing of one line), including both the horizontal sync pulse and the data. All the parameters shown in the figure are programmable. All controls are started by corresponding internal events—local start points. The timing diagrams correspond to inverse polarity of the IPP_DISP_CLK signal and active-low polarity of the HSYNC, VSYNC, and DRDY signals.

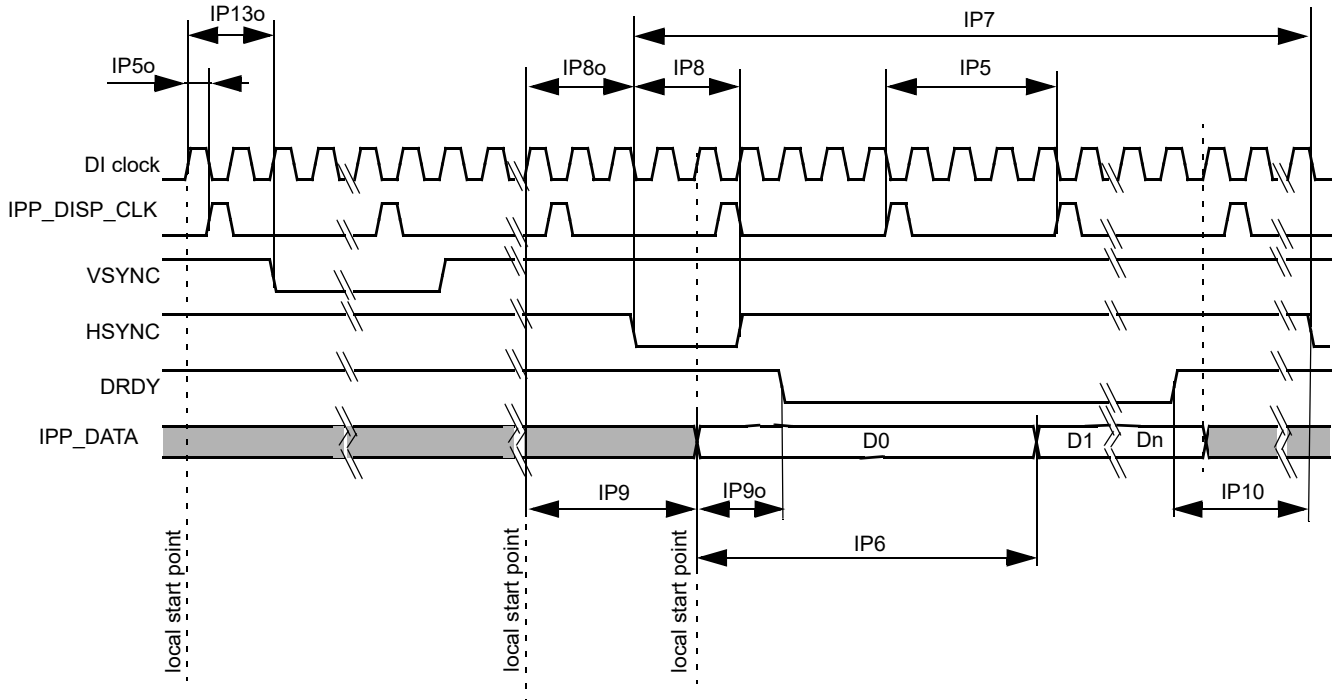

Figure 48. TFT Panels Timing Diagram—Horizontal Sync Pulse

Figure 49 depicts the vertical timing (timing of one frame). All parameters shown in the figure are programmable.

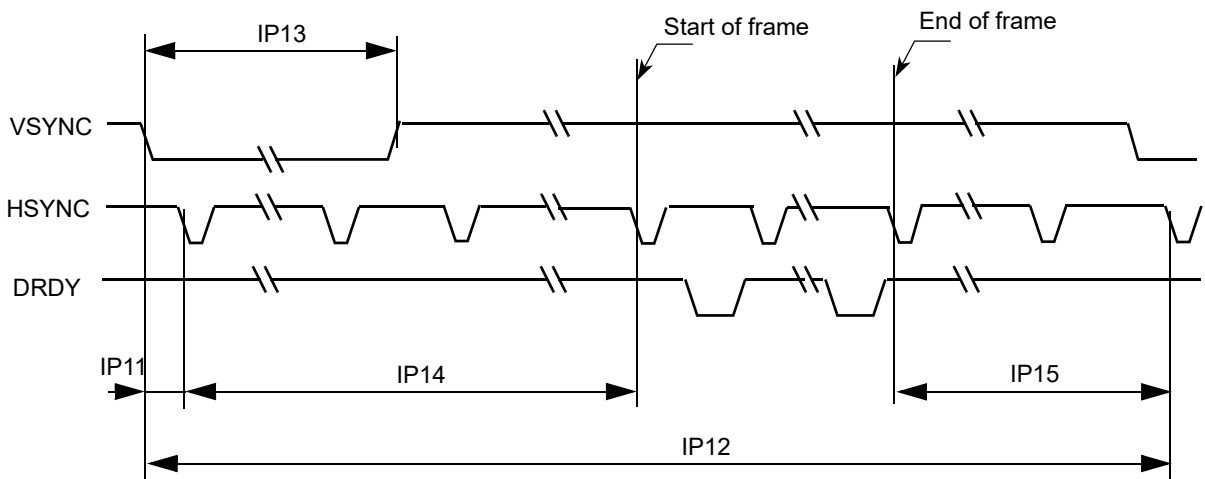

Figure 49. TFT Panels Timing Diagram—Vertical Sync Pulse

Table 63 shows timing characteristics of signals presented in Figure 48 and Figure 49.

Table 63. Synchronous Display Interface Timing Characteristics (Pixel Level)

ID	Parameter	Symbol	Value	Description	Unit
IP5	Display interface clock period	Tdicp	(¹)	Display interface clock. IPP_DISP_CLK	ns
IP6	Display pixel clock period	Tdpcp	$DISP_CLK_PER_PIXEL \times Tdicp$	Time of translation of one pixel to display, DISP_CLK_PER_PIXEL—number of pixel components in one pixel (1.n). The DISP_CLK_PER_PIXEL is virtual parameter to define Display pixel clock period. The DISP_CLK_PER_PIXEL is received by DC/DI one access division to n components.	ns
IP7	Screen width time	Tsw	$(SCREEN_WIDTH) \times Tdicp$	SCREEN_WIDTH—screen width in, interface clocks. horizontal blanking included. The SCREEN_WIDTH should be built by suitable DI's counter ² .	ns
IP8	HSYNC width time	Thsw	(HSYNC_WIDTH)	HSYNC_WIDTH—Hsync width in DI_CLK with 0.5 DI_CLK resolution. Defined by DI's counter.	ns
IP9	Horizontal blank interval 1	Thbi1	$BGXP \times Tdicp$	BGXP—width of a horizontal blanking before a first active data in a line (in interface clocks). The BGXP should be built by suitable DI's counter.	ns
IP10	Horizontal blank interval 2	Thbi2	$(SCREEN_WIDTH - BGXP - FW) \times Tdicp$	Width a horizontal blanking after a last active data in a line (in interface clocks) FW—width of active line in interface clocks. The FW should be built by suitable DI's counter.	ns
IP12	Screen height	Tsh	$(SCREEN_HEIGHT) \times Tsw$	SCREEN_HEIGHT— screen height in lines with blanking. The SCREEN_HEIGHT is a distance between 2 VSYNCs. The SCREEN_HEIGHT should be built by suitable DI's counter.	ns
IP13	VSYNC width	Tvsw	VSYNC_WIDTH	VSYNC_WIDTH—Vsync width in DI_CLK with 0.5 DI_CLK resolution. Defined by DI's counter	ns
IP14	Vertical blank interval 1	Tvbi1	$BGYP \times Tsw$	BGYP—width of first Vertical blanking interval in line.The BGYP should be built by suitable DI's counter.	ns
IP15	Vertical blank interval 2	Tvbi2	$(SCREEN_HEIGHT - BGYP - FH) \times Tsw$	Width of second Vertical blanking interval in line.The FH should be built by suitable DI's counter.	ns

Table 63. Synchronous Display Interface Timing Characteristics (Pixel Level) (continued)

ID	Parameter	Symbol	Value	Description	Unit
IP5o	Offset of IPP_DISP_CLK	Todicp	DISP_CLK_OFFSET × Tdiclk	DISP_CLK_OFFSET—offset of IPP_DISP_CLK edges from local start point, in DI_CLK×2 (0.5 DI_CLK Resolution) Defined by DISP_CLK counter	ns
IP13o	Offset of VSYNC	Tovs	VSYNC_OFFSET × Tdiclk	VSYNC_OFFSET—offset of Vsync edges from a local start point, when a Vsync should be active, in DI_CLK×2 (0.5 DI_CLK Resolution).The VSYNC_OFFSET should be built by suitable DI's counter.	ns
IP8o	Offset of HSYNC	Tohs	HSYNC_OFFSET × Tdiclk	HSYNC_OFFSET—offset of Hsync edges from a local start point, when a Hsync should be active, in DI_CLK×2 (0.5 DI_CLK Resolution).The HSYNC_OFFSET should be built by suitable DI's counter.	ns
IP9o	Offset of DRDY	Todrdy	DRDY_OFFSET × Tdiclk	DRDY_OFFSET—offset of DRDY edges from a suitable local start point, when a corresponding data has been set on the bus, in DI_CLK×2 (0.5 DI_CLK Resolution) The DRDY_OFFSET should be built by suitable DI's counter.	ns

¹ Display interface clock period immediate value.

$$T_{dicp} = \begin{cases} T_{diclk} \times \frac{DISP_CLK_PERIOD}{DI_CLK_PERIOD}, & \text{for integer } \frac{DISP_CLK_PERIOD}{DI_CLK_PERIOD} \\ T_{diclk} \left(\text{floor} \left[\frac{DISP_CLK_PERIOD}{DI_CLK_PERIOD} \right] + 0.5 \pm 0.5 \right), & \text{for fractional } \frac{DISP_CLK_PERIOD}{DI_CLK_PERIOD} \end{cases}$$

DISP_CLK_PERIOD—number of DI_CLK per one Tdicp. Resolution 1/16 of DI_CLK.

DI_CLK_PERIOD—relation of between programing clock frequency and current system clock frequency

Display interface clock period average value.

$$\bar{T}_{dicp} = T_{diclk} \times \frac{DISP_CLK_PERIOD}{DI_CLK_PERIOD}$$

² DI's counter can define offset, period and UP/DOWN characteristic of output signal according to programed parameters of the counter. Same of parameters in the table are not defined by DI's registers directly (by name), but can be generated by corresponding DI's counter. The SCREEN_WIDTH is an input value for DI's HSYNC generation counter. The distance between HSYNCs is a SCREEN_WIDTH.

The maximal accuracy of UP/DOWN edge of controls is:

$$\text{Accuracy} = (0.5 \times T_{diclk}) \pm 0.62\text{ns}$$

The maximal accuracy of UP/DOWN edge of IPP_DATA is:

$$\text{Accuracy} = T_{\text{diclk}} \pm 0.62\text{ns}$$

The DISP_CLK_PERIOD, DI_CLK_PERIOD parameters are programmed through the registers.

Figure 50 depicts the synchronous display interface timing for access level. The DISP_CLK_DOWN and DISP_CLK_UP parameters are set through the Register. Table 64 lists the synchronous display interface timing characteristics.

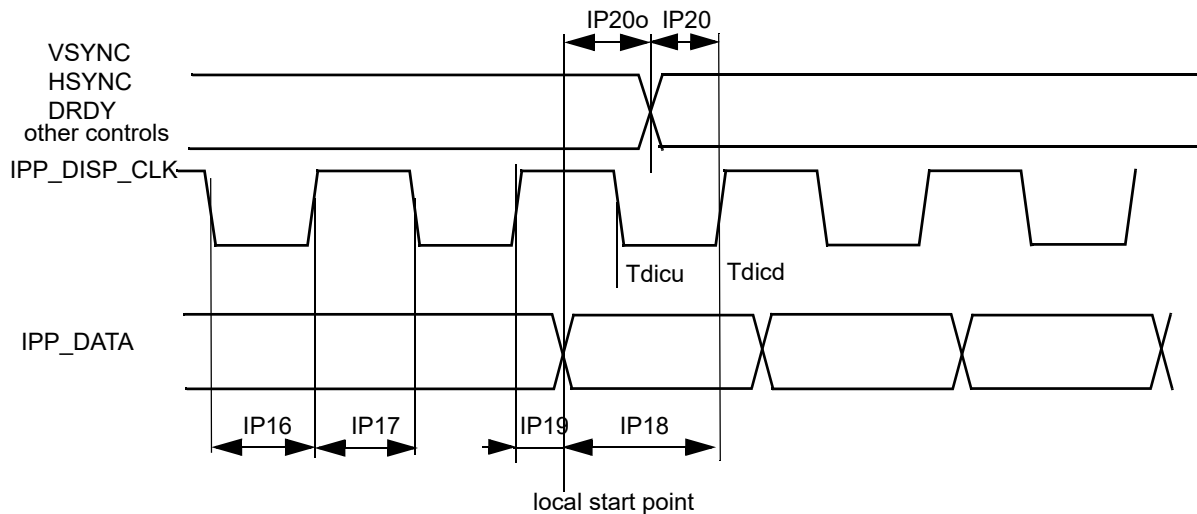

Figure 50. Synchronous Display Interface Timing Diagram—Access Level

Table 64. Synchronous Display Interface Timing Characteristics (Access Level)

ID	Parameter	Symbol	Min	Typ ¹	Max	Unit
IP16	Display interface clock low time	Tckl	Tdicd-Tdicu-1.24	Tdicd ² -Tdicu ³	Tdicd-Tdicu+1.24	ns
IP17	Display interface clock high time	Tckh	Tdicp-Tdicd+Tdicu-1.24	Tdicp-Tdicd+Tdicu	Tdicp-Tdicd+Tdicu+1.2	ns
IP18	Data setup time	Tdsu	Tdicd-1.24	Tdicu	—	ns
IP19	Data holdup time	Tdhd	Tdicp-Tdicd-1.24	Tdicp-Tdicu	—	ns
IP20o	Control signals offset times (defines for each pin)	Tocsu	Tocsu-1.24	Tocsu	Tocsu+1.24	ns
IP20	Control signals setup time to display interface clock (defines for each pin)	Tcsu	Tdicd-1.24-Tocsu%Tdicp	Tdicu	—	ns

¹The exact conditions have not been finalized, but will likely match the current customer requirement for their specific display. These conditions may be chip specific.

Electrical Characteristics

² Display interface clock down time

$$T_{d\text{icd}} = \frac{1}{2} \left(T_{d\text{iclk}} \times \text{ceil} \left[\frac{2 \times \text{DISP_CLK_DOWN}}{\text{DI_CLK_PERIOD}} \right] \right)$$

³ Display interface clock up time where CEIL(X) rounds the elements of X to the nearest integers towards infinity.

$$T_{d\text{icu}} = \frac{1}{2} \left(T_{d\text{iclk}} \times \text{ceil} \left[\frac{2 \times \text{DISP_CLK_UP}}{\text{DI_CLK_PERIOD}} \right] \right)$$

4.7.8.7 Interface to a TV Encoder (TVDAC)

The interface has an 8-bit data bus, transferring a single 8-bit value (Y/U/V) in each cycle. The timing of the interface is described in [Figure 51](#).

NOTE

- The frequency of the clock DISP_CLK is 27 MHz (within 10%)
- The HSYNC, VSYNC signals are active low.
- The DRDY signal is shown as active high.
- The transition to the next row is marked by the negative edge of the HSYNC signal. It remains low for a single clock cycle.
- The transition to the next field/frame is marked by the negative edge of the VSYNC signal. It remains low for at least one clock cycles.
 - At a transition to an odd field (of the next frame), the negative edges of VSYNC and HSYNC coincide.
 - At a transition to an even field (of the same frame), they do not coincide.
- The active intervals—during which data is transferred—are marked by the HSYNC signal being high.

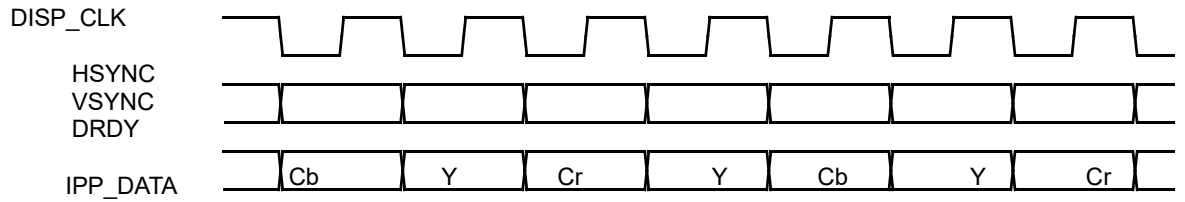

Pixel Data Timing

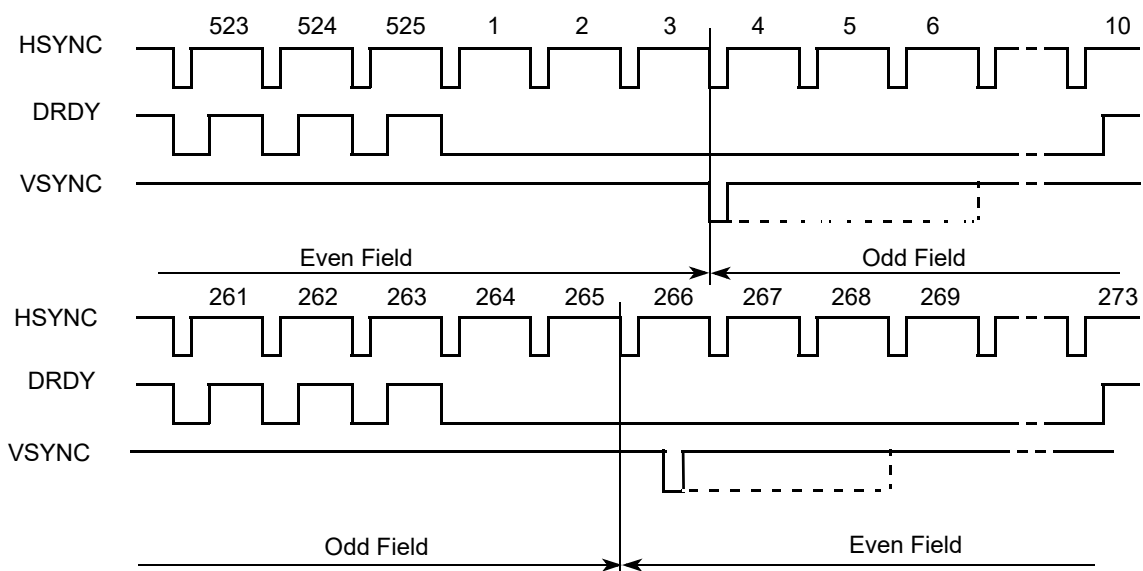

Line and Field Timing - NTSC

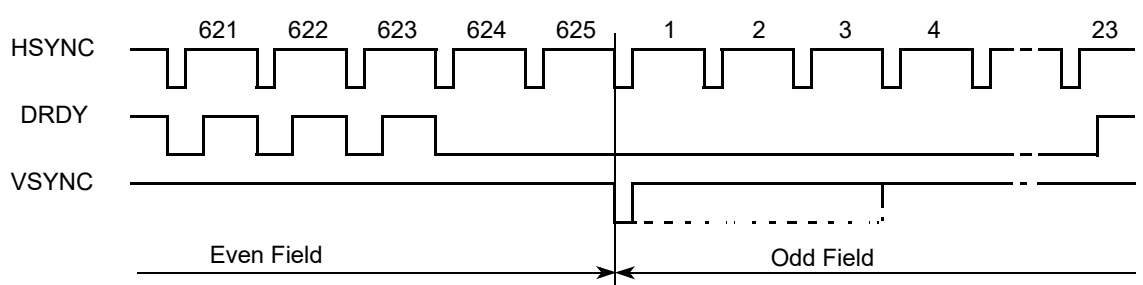

Line and Field Timing - PAL

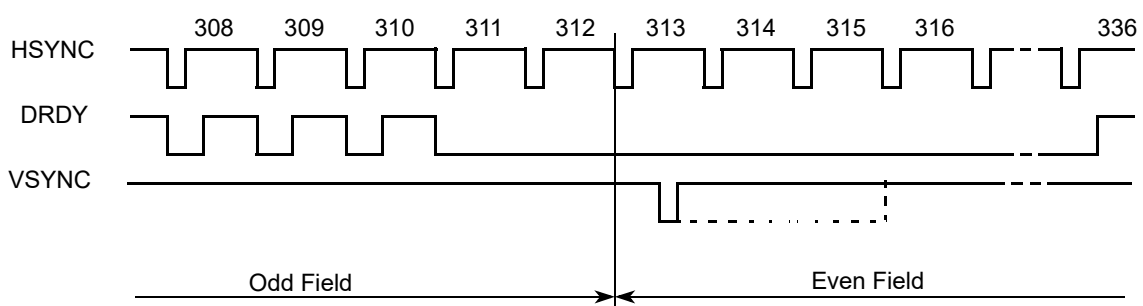

Figure 51. TV Encoder Interface Timing Diagram

4.7.8.7.1 TVEv2 TV Encoder Performance Specifications

The TV encoder output specifications are shown in [Table 65](#). All the parameters in the table are defined under the following conditions:

- $R_{\text{set}} = 1.05 \text{ k}\Omega \pm 1\%$, resistor on TVDAC_VREF pin to GND
- $R_{\text{load}} = 37.5 \text{ }\Omega \pm 1\%$, output load to the GND

Table 65. TV Encoder Video Performance Specifications

Parameter	Conditions	Min	Typ	Max	Unit
DAC STATIC PERFORMANCE					
Resolution ¹	—	—	10	—	Bits
Integral Nonlinearity (INL) ²	—	—	1	2	LSBs
Differential Nonlinearity (DNL) ²	—	—	0.6	1	LSBs
Channel-to-channel gain matching ²	—	—	2	—	%
Full scale output voltage ²	$R_{\text{set}} = 1.05 \text{ k}\Omega \pm 1\%$ $R_{\text{load}} = 37.5 \text{ }\Omega \pm 1\%$	1.24	1.306	1.37	V
DAC DYNAMIC PERFORMANCE					
Spurious Free Dynamic Range (SFDR)	$F_{\text{out}} = 3.38 \text{ MHz}$ $F_{\text{samp}} = 216 \text{ MHz}$	—	59	—	dBc
Spurious Free Dynamic Range (SFDR)	$F_{\text{out}} = 8.3 \text{ MHz}$ $F_{\text{samp}} = 297 \text{ MHz}$	—	54	—	dBc
VIDEO PERFORMANCE IN SD MODE²					
Short Term Jitter (Line to Line)	—	—	2.5	—	±ns
Long Term Jitter (Field to Field)	—	—	3.5	—	±ns
Frequency Response	0–4.0 MHz	-0.1	—	0.1	dB
	5.75 MHz	-0.7	—	0	dB
Luminance Nonlinearity	—	—	0.5	—	±%
Differential Gain	—	—	0.35	—	%
Differential Phase	—	—	0.6	—	Degrees
Signal-to-Noise Ratio (SNR)	Flat field full bandwidth	—	75	—	dB
Hue Accuracy	—	—	0.8	—	±Degrees
Color Saturation Accuracy	—	—	1.5	—	±%
Chroma AM Noise	—	—	-70	—	dB
Chroma PM Noise	—	—	-47	—	dB
Chroma Nonlinear Phase	—	—	0.5	—	±Degrees
Chroma Nonlinear Gain	—	—	2.5	—	±%
Chroma/Luma Intermodulation	—	—	0.1	—	±%
Chroma/Luma Gain Inequality	—	—	1.0	—	±%

Table 65. TV Encoder Video Performance Specifications (continued)

Parameter	Conditions	Min	Typ	Max	Unit
Chroma/Luma Delay Inequality	—	—	1.0	—	±ns
VIDEO PERFORMANCE IN HD MODE²					
Luma Frequency Response	0–30 MHz	-0.2	—	0.2	dB
Chroma Frequency Response	0–15 MHz, YCbCr 422 mode	-0.2	—	0.2	dB
Luma Nonlinearity	—	—	3.2	—	%
Chroma Nonlinearity	—	—	3.4	—	%
Luma Signal-to-Noise Ratio	0–30 MHz	—	62	—	dB
Chroma Signal-to-Noise Ratio	0–15 MHz	—	72	—	dB

¹ Guaranteed by design.

² Guaranteed by characterization.

4.7.8.8 Asynchronous Interfaces

The following sections describes the types of asynchronous interfaces.

4.7.8.8.1 Standard Parallel Interfaces

The IPU has four signal generator machines for asynchronous signal. Each machine generates IPU's internal control levels (0 or 1) by UP and DOWN that are defined in registers. Each asynchronous pin has a dynamic connection with one of the signal generators. This connection is redefined again with a new display access (pixel/component). The IPU can generate control signals according to system 80/68 requirements. The burst length is received as a result from predefined behavior of the internal signal generator machines.

The access to a display is realized by the following:

- CS (IPP_CS) chip select
- WR (IPP_PIN_11) write strobe
- RD (IPP_PIN_12) read strobe
- RS (IPP_PIN_13) Register select (A0)

Both system 80 and system 68k interfaces are supported for all described modes as depicted in [Figure 52](#), [Figure 53](#), [Figure 54](#), and [Figure 55](#). The timing images correspond to active-low IPP_CS, WR and RD signals.

Each asynchronous access is defined by an access size parameter. This parameter can be different between different kinds of accesses. This parameter defines a length of windows, when suitable controls of the current access are valid. A pause between two different display accesses can be guaranteed by programing suitable access sizes. There are no minimal/maximal hold/setup times hard defined by DI. Each control signal can be switched at any time during access size.

Electrical Characteristics

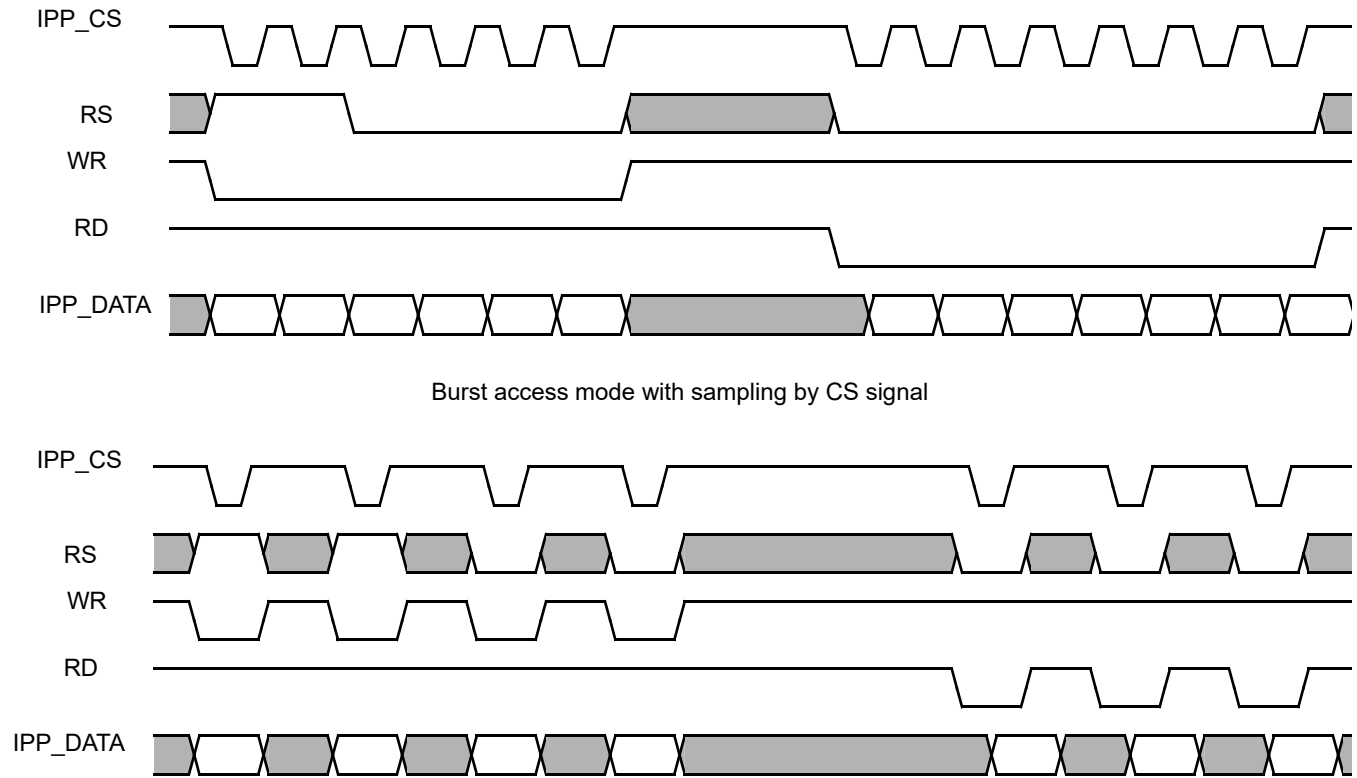

Single access mode (all control signals are not active for one display interface clock after each display access)

Figure 52. Asynchronous Parallel System 80 Interface (Type 1) Timing Diagram

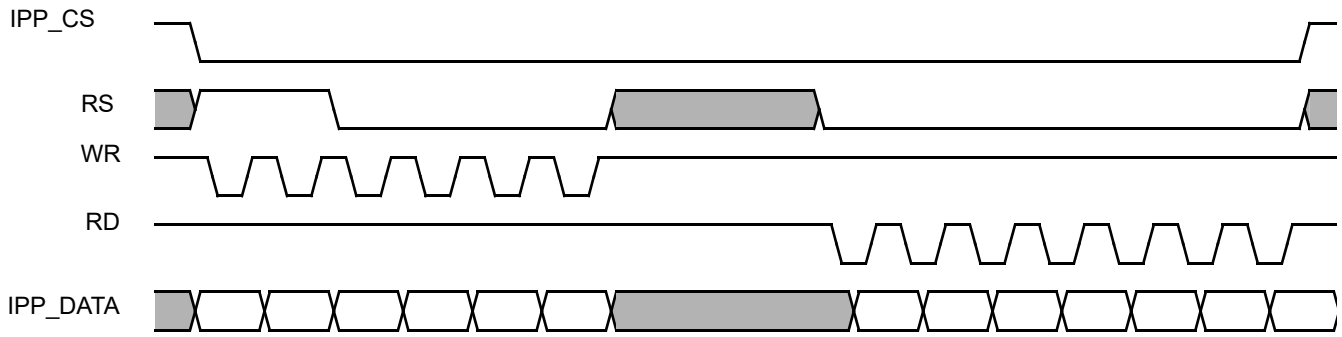

Burst access mode with sampling by WR/RD signals

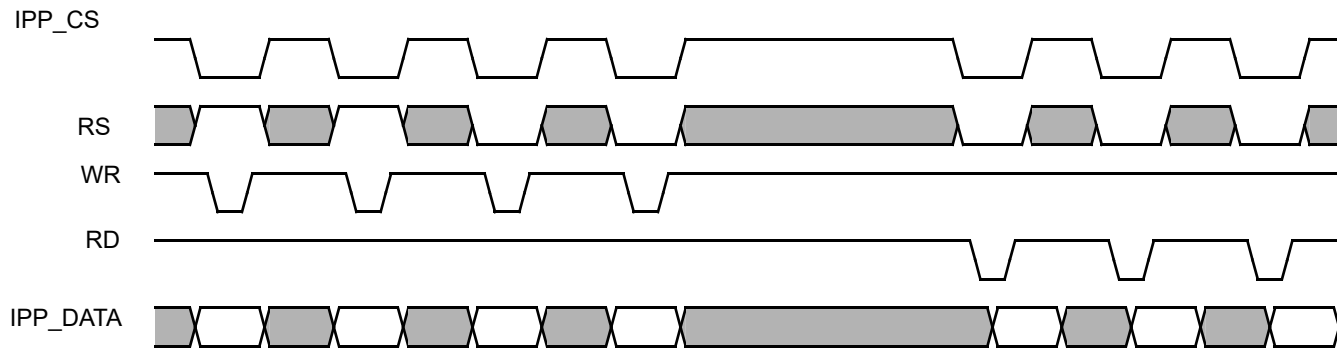

Single access mode (all control signals are not active for one display interface clock after each display access)

Figure 53. Asynchronous Parallel System 80 Interface (Type 2) Timing Diagram

Electrical Characteristics

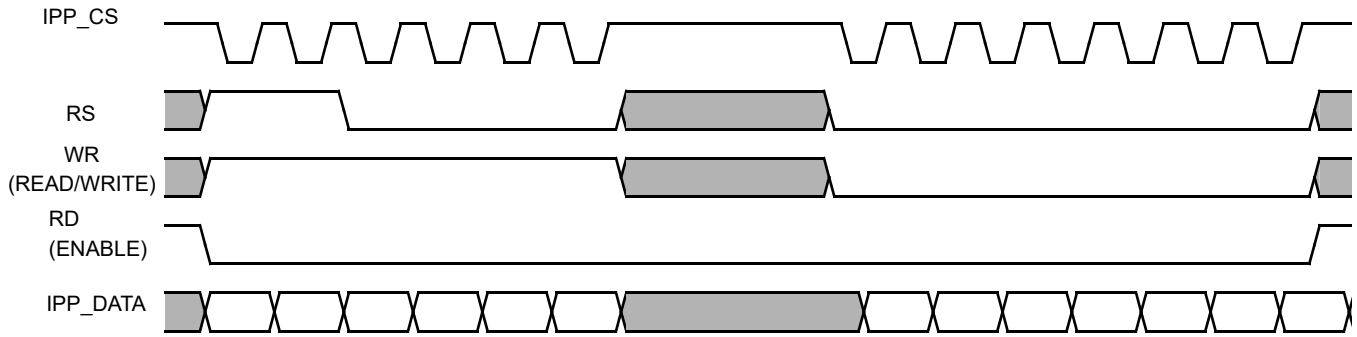

Burst access mode with sampling by CS signal

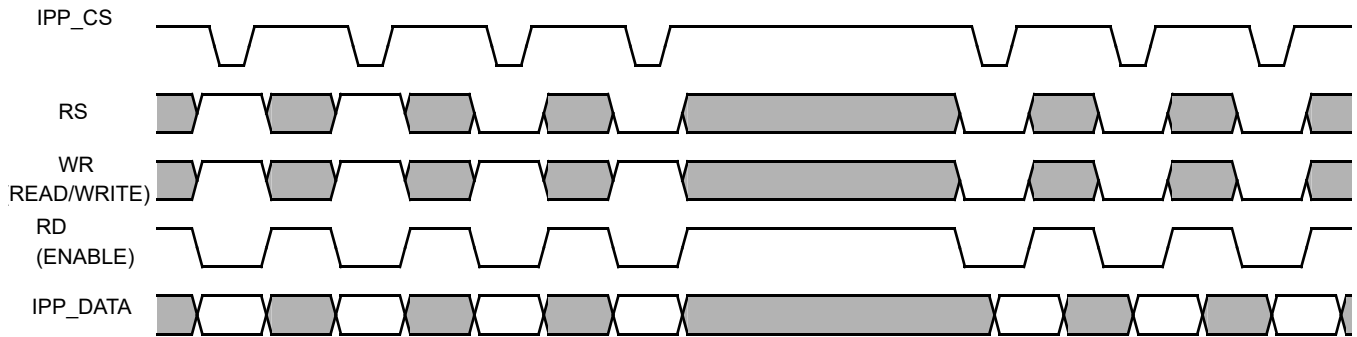

Single access mode (all control signals are not active for one display interface clock after each display access)

Figure 54. Asynchronous Parallel System 68k Interface (Type 1) Timing Diagram

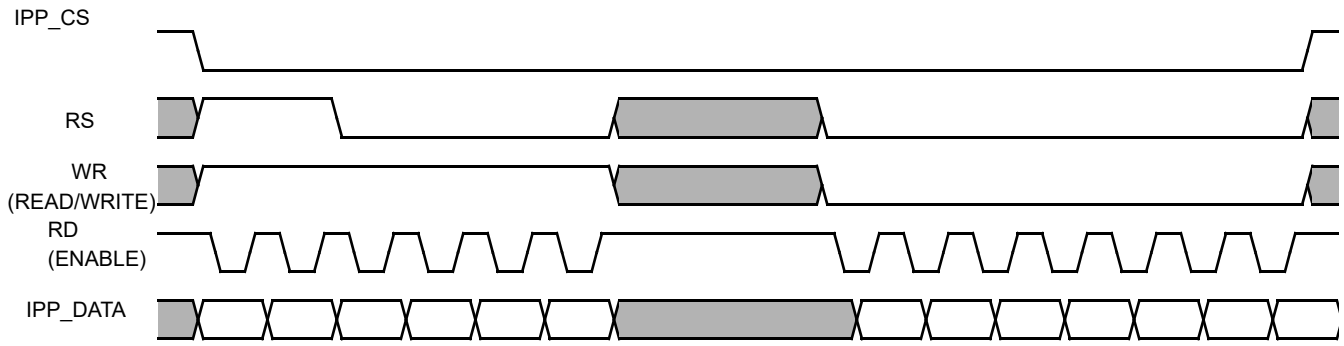

Burst access mode with sampling by ENABLE signal

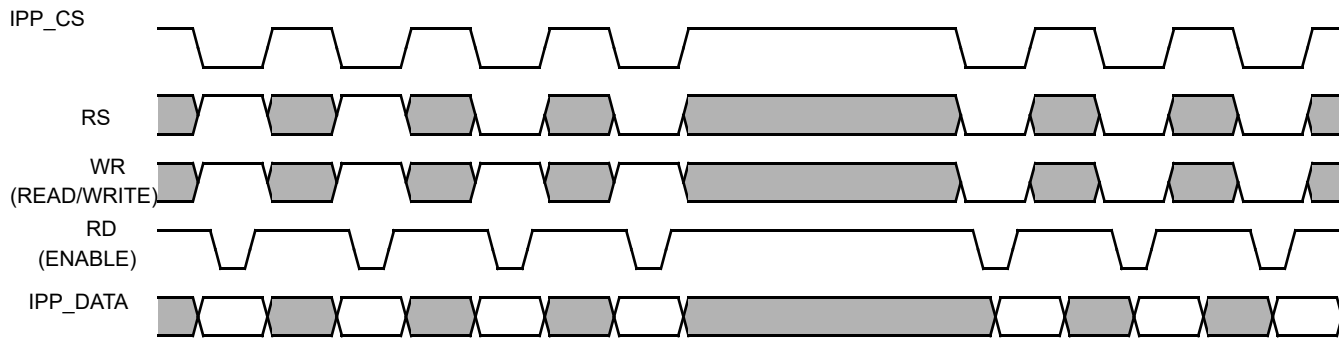

Single access mode (all control signals are not active for one display interface clock after each display access)

Figure 55. Asynchronous Parallel System 68k Interface (Type 2) Timing Diagram

Display operation can be performed with IPP_WAIT signal. The DI reacts to the incoming IPP_WAIT signal with 2 DI_CLK delay. The DI finishes a current access and a next access is postponed until IPP_WAIT release. [Figure 56](#) shows timing of the parallel interface with IPP_WAIT control.

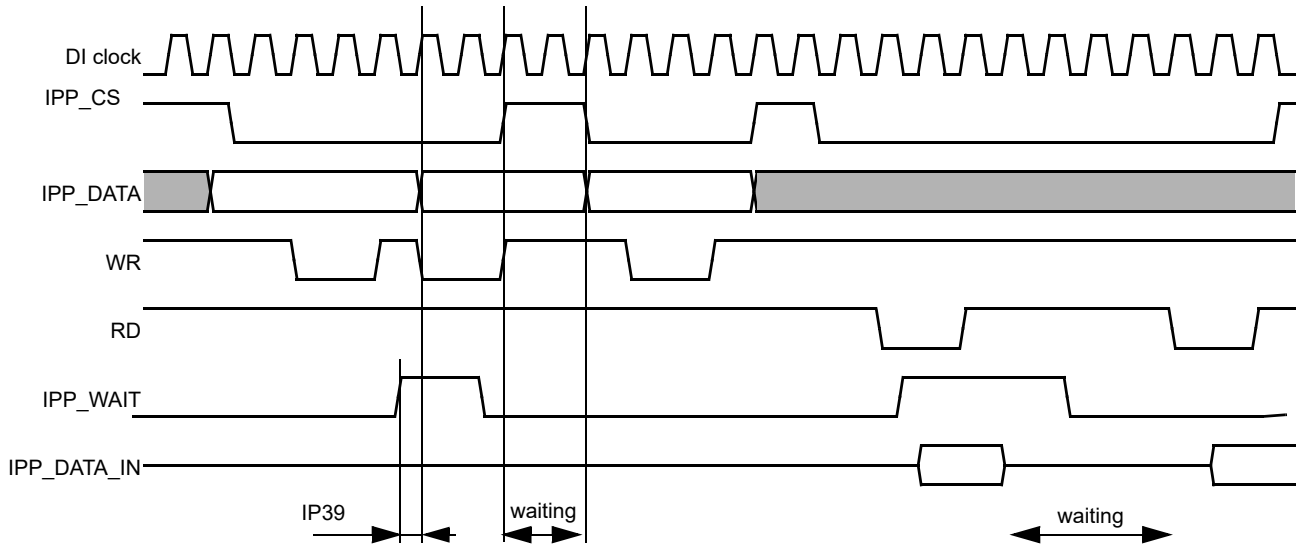

Figure 56. Parallel Interface Timing Diagram—Read Wait States

4.7.8.8.2 Asynchronous Parallel Interface Timing Parameters

Figure 57 depicts timing of asynchronous parallel interfaces based on the system 80 and system 68k interfaces. Table 67 shows timing characteristics at display access level. All timing diagrams are based on active low control signals (signals polarity is controlled through the DI_DISP_SIG_POL register).

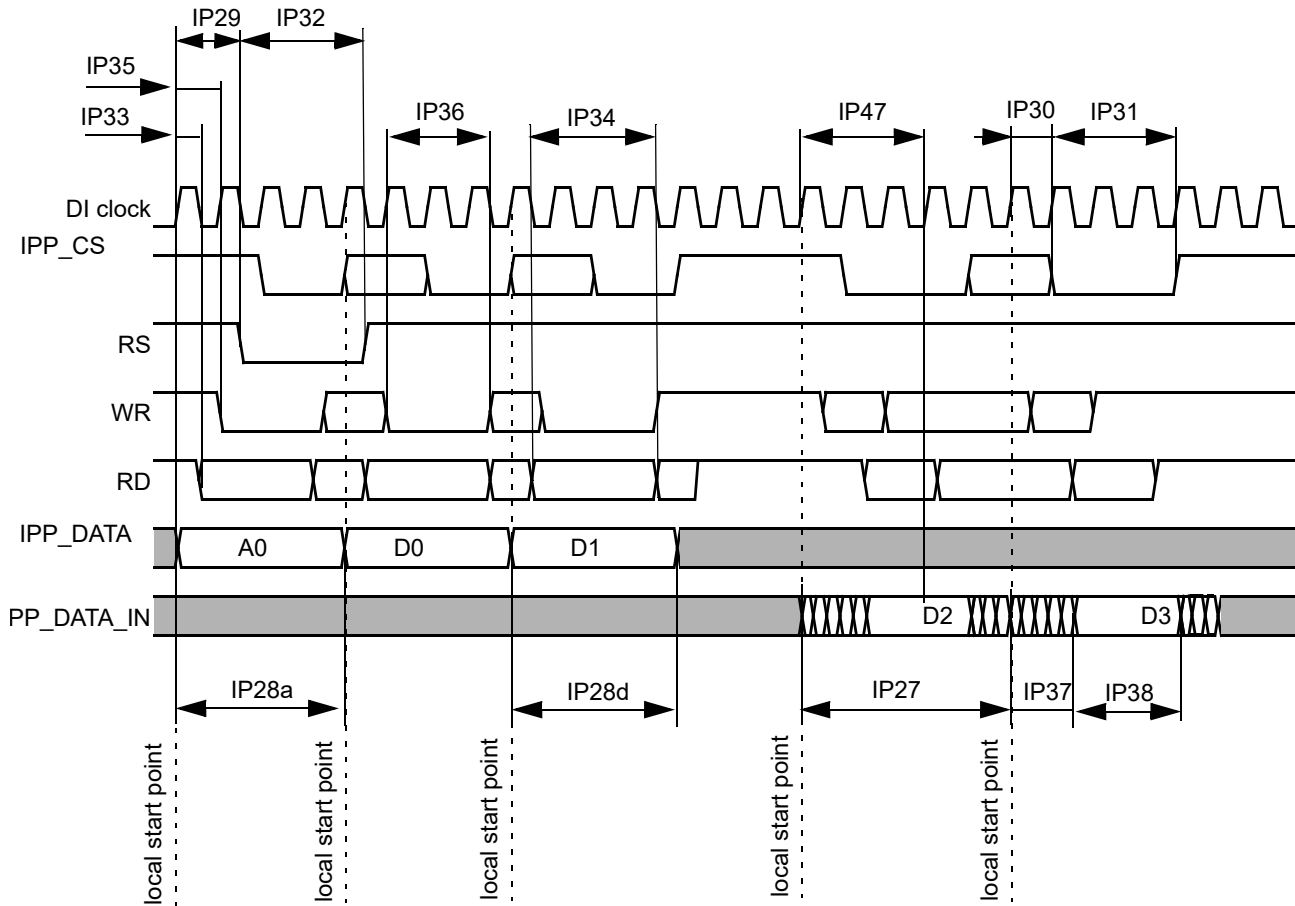

Figure 57. Asynchronous Parallel Interface Timing Diagram

Table 66. Asynchronous Display Interface Timing Parameters (Pixel Level)

ID	Parameter	Symbol	Value	Description	Unit
IP28a	Address Write system cycle time	Tcycwa	ACCESS_SIZE_#	predefined value in DI REGISTER	ns
IP28d	Data Write system cycle time	Tcycwd	ACCESS_SIZE_#	predefined value in DI REGISTER	ns
IP29	RS start	Tdcsrr	UP#	RS strobe switch, predefined value in DI REGISTER	ns
IP30	CS start	Tdcsc	UP#	CS strobe switch, predefined value in DI REGISTER	ns
IP31	CS hold	Tdchc	DOWN#	CS strobe release, predefined value in DI REGISTER	—
IP32	RS hold	Tdchrr	DOWN#	RS strobe release, predefined value in DI REGISTER	—
IP35	Write start	Tdcsw	UP#	write strobe switch, predefined value in DI REGISTER	ns
IP36	Controls hold time for write	Tdchw	DOWN#	write strobe release, predefined value in DI REGISTER	ns

Table 67. Asynchronous Parallel Interface Timing Parameters (Access Level)

ID	Parameter	Symbol	Min	Typ ¹	Max	Unit
IP28	Write system cycle time	Tcycw	Tdicpw - 1.24	Tdicpw ²	Tdicpw+1.24	ns
IP29	RS start	Tdcsrr	Tdicurs - 1.24	Tdicurs	Tdicurs+1.24	ns
IP30	CS start	Tdcsc	Tdicucs - 1.24	Tdicur	Tdicucs+1.24	ns
IP31	CS hold	Tdchc	Tdicdcs - Tdicucs - 1.24	Tdicdcs ³ -Tdicucs ⁴	Tdicdcs - Tdicucs+1.24	ns
IP32	RS hold	Tdchrr	Tdicdrs - Tdicurs - 1.24	Tdicdrs ⁵ -Tdicurs ⁶	Tdicdrs - Tdicurs+1.24	ns
IP35	Controls setup time for write	Tdcsw	Tdicuw - 1.24	Tdicuw	Tdicuw+1.24	ns
IP36	Controls hold time for write	Tdchw	Tdicdw - Tdicuw - 1.24	Tdicpw ⁷ -Tdicuw ⁸	Tdicdw-Tdicuw+1.24	ns
IP38	Slave device data hold time ⁸	Troh	Tdrp - Tlbd - Tdicdr+1.24 4	—	Tdicpr - Tdicdr - 1.24	ns

¹The exact conditions have not been finalized, but will likely match the current customer requirement for their specific display. These conditions may be chip specific.

²Display period value for write

$$T_{dicpw} = T_{DI_CLK} \times \text{ceil} \left[\frac{DI_ACCESS_SIZE \#}{DI_CLK_PERIOD} \right]$$

ACCESS_SIZE is predefined in REGISTER.

³Display control down for CS

$$T_{dicdcs} = \frac{1}{2} \left(T_{DI_CLK} \times \text{ceil} \left[\frac{2 \times DISP_DOWN \#}{DI_CLK_PERIOD} \right] \right)$$

DISP_DOWN is predefined in REGISTER.

⁴Display control up for CS

$$T_{dicucs} = \frac{1}{2} \left(T_{DI_CLK} \times \text{ceil} \left[\frac{2 \times DISP_UP \#}{DI_CLK_PERIOD} \right] \right)$$

DISP_UP is predefined in REGISTER.

⁵Display control down for RS

$$T_{dicdrs} = \frac{1}{2} \left(T_{DI_CLK} \times \text{ceil} \left[\frac{2 \times DISP_DOWN \#}{DI_CLK_PERIOD} \right] \right)$$

DISP_DOWN is predefined in REGISTER.

⁶Display control up for RS

$$T_{dicurs} = \frac{1}{2} \left(T_{DI_CLK} \times \text{ceil} \left[\frac{2 \times DISP_UP \#}{DI_CLK_PERIOD} \right] \right)$$

DISP_UP is predefined in REGISTER.

⁷Display control down for read

$$T_{dicdrw} = \frac{1}{2} \left(T_{DI_CLK} \times \text{ceil} \left[\frac{2 \times \text{DISP_DOWN \#}}{DI_CLK_PERIOD} \right] \right)$$

DISP_DOWN is predefined in REGISTER.

⁸Display control up for write

$$T_{dicuw} = \frac{1}{2} \left(T_{DI_CLK} \times \text{ceil} \left[\frac{2 \times \text{DISP_UP \#}}{DI_CLK_PERIOD} \right] \right)$$

DISP_UP is predefined in REGISTER.

4.7.9 LVDS Display Bridge (LDB) Module Parameters

The LVDS interface complies with TIA/EIA 644-A standard. For more details, see TIA/EIA STANDARD 644-A, “Electrical Characteristics of Low Voltage Differential Signaling (LVDS) Interface Circuits”.

4.7.10 One-Wire (OWIRE) Timing Parameters

Figure 58 depicts the RPP timing, and Table 68 lists the RPP timing parameters.

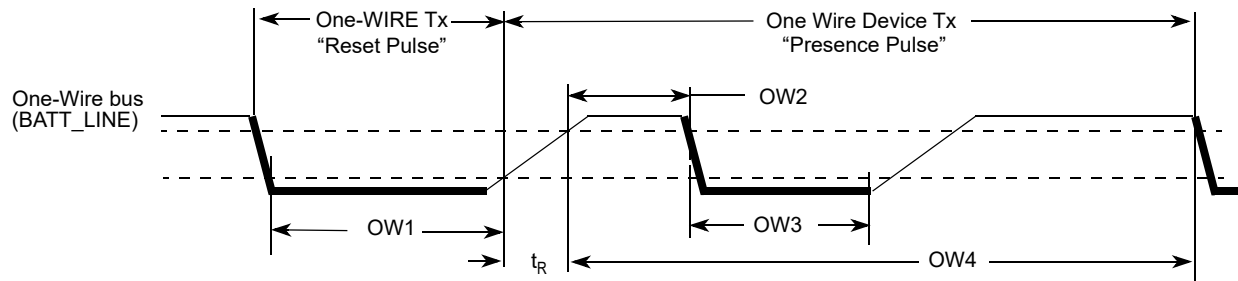

Figure 58. Reset and Presence Pulses (RPP) Timing Diagram

Table 68. RPP Sequence Delay Comparisons Timing Parameters

ID	Parameters	Symbol	Min	Typ	Max	Unit
OW1	Reset Time Low	t_{RSTL}	480	511	— ¹	μs
OW2	Presence Detect High	t_{PDH}	15	—	60	μs
OW3	Presence Detect Low	t_{PDL}	60	—	240	μs
OW4	Reset Time High (includes recovery time)	t_{RSTH}	480	512	—	μs

¹ In order not to mask signaling by other devices on the 1-Wire bus, $t_{RSTL} + t_R$ should always be less than 960 μs .

Figure 59 depicts Write 0 Sequence timing, and Table 69 lists the timing parameters.

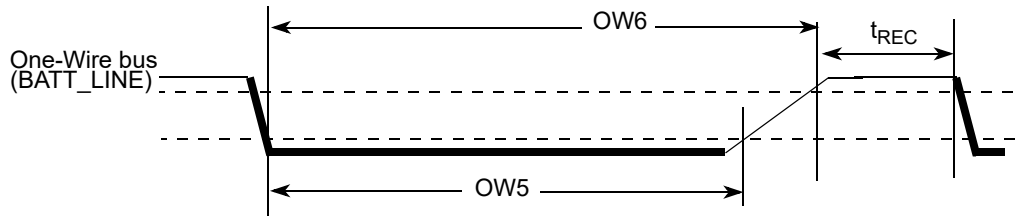

Figure 59. Write 0 Sequence Timing Diagram

Table 69. WR0 Sequence Timing Parameters

ID	Parameter	Symbol	Min	Typ	Max	Unit
OW5	Write 0 Low Time	t _{LOW0}	60	100	120	μs
OW6	Transmission Time Slot	t _{SLOT}	OW5	117	120	μs
	Recovery time	t _{REC}	1	—	—	μs

Figure 60 depicts Write 1 Sequence timing, Figure 61 depicts the Read Sequence timing, and Table 70 lists the timing parameters.

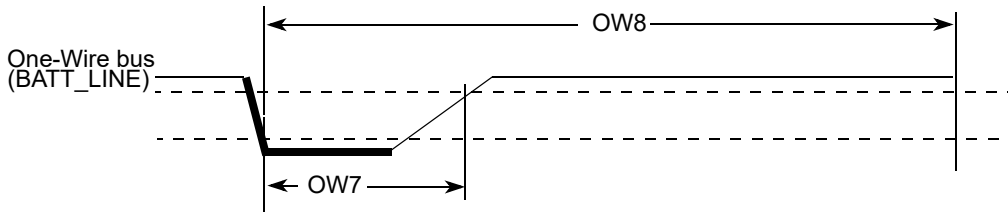

Figure 60. Write 1 Sequence Timing Diagram

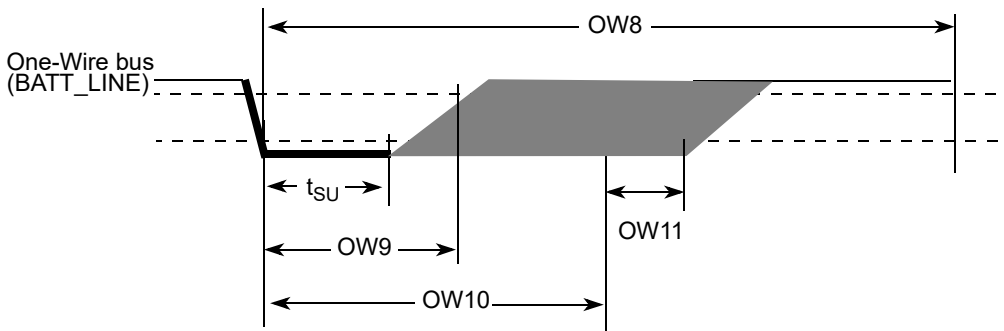

Figure 61. Read Sequence Timing Diagram

Table 70. WR1 /RD Timing Parameters

ID	Parameter	Symbol	Min	Typ	Max	Unit
OW7	Write 1 Low Time	t_{LOW1}	1	5	15	μs
OW8	Transmission Time Slot	t_{SLOT}	60	117	120	μs
	Read Data Setup	t_{SU}	—	—	1	μs
OW9	Read Low Time	t_{LOWR}	1	5	15	μs
OW10	Read Data Valid	t_{RDV}	—	15	—	μs
OW11	Release Time	$t_{RELEASE}$	0	—	45	μs

4.7.11 Pulse Width Modulator (PWM) Timing Parameters

This section describes the electrical information of the PWM. The PWM can be programmed to select one of three clock signals as its source frequency. The selected clock signal is passed through a prescaler before being input to the counter. The output is available at the pulse-width modulator output (PWMO) external pin.

Figure 62 depicts the timing of the PWM, and Table 71 lists the PWM timing parameters.

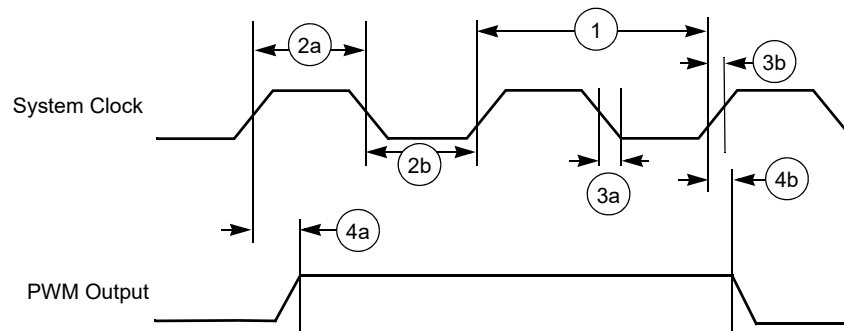

Figure 62. PWM Timing

Table 71. PWM Output Timing Parameter

Ref. No.	Parameter	Min	Max	Unit
1	System CLK frequency ¹	0	ipg_clk	MHz
2a	Clock high time	12.29	—	ns
2b	Clock low time	9.91	—	ns
3a	Clock fall time	—	0.5	ns
3b	Clock rise time	—	0.5	ns
4a	Output delay time	—	9.37	ns
4b	Output setup time	8.71	—	ns

¹ CL of PWMO = 30 pF

4.7.12 PATA Timing Parameters

This section describes the timing parameters of the Parallel ATA module which are compliant with ATA/ATAPI-6 specification.

Parallel ATA module can work on PIO/Multi-Word DMA/Ultra DMA transfer modes. Each transfer mode has different data transfer rate, Ultra DMA mode 4 data transfer rate is up to 100MB/s. Parallel ATA module interface consist of a total of 29 pins. Some pins act on different function in different transfer mode. There are different requirements of timing relationships among the function pins conform with ATA/ATAPI-6 specification and these requirements are configurable by the ATA module registers.

Table 72 and Figure 63 define the AC characteristics of all the PATA interface signals in all data transfer modes.

ATA Interface Signals

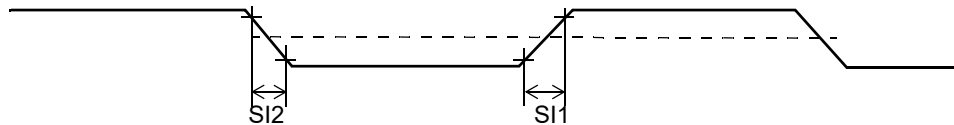

Figure 63. PATA Interface Signals Timing Diagram

Table 72. AC Characteristics of All Interface Signals

ID	Parameter	Symbol	Min	Max	Unit
SI1	Rising edge slew rate for any signal on ATA interface ¹	S _{rise}	—	1.25	V/ns
SI2	Falling edge slew rate for any signal on ATA interface ¹	S _{fall}	—	1.25	V/ns
SI3	Host interface signal capacitance at the host connector	C _{host}	—	20	pF

¹ SRISE and SFALL shall meet this requirement when measured at the sender’s connector from 10–90% of full signal amplitude with all capacitive loads from 15–40 pF where all signals have the same capacitive load value.

The user must use level shifters for 5.0 V compatibility on the ATA interface. The i.MX53 PATA interface is 3.3 V compatible.

The use of bus buffers introduces delay on the bus and skew between signal lines. These factors make it difficult to operate the bus at the highest speed (UDMA-5) when bus buffers are used. If fast UDMA mode operation is needed, this may not be compatible with bus buffers.

Another area of attention is the slew rate limit imposed by the ATA specification on the ATA bus. According to this limit, any signal driven on the bus should have a slew rate between 0.4 and 1.2 V/ns with a 40 pF load. Not many vendors of bus buffers specify slew rate of the outgoing signals.

When bus buffers are used, the ata_data bus buffer is special. This is a bidirectional bus buffer, so a direction control signal is needed. This direction control signal is ata_buffer_en. When its high, the bus should drive from host to device. When its low, the bus should drive from device to host. Steering of the signal is such that contention on the host and device tri-state busses is always avoided.

In the timing equations, some timing parameters are used. These parameters depend on the implementation of the i.MX53 PATA interface on silicon, the bus buffer used, the cable delay and cable skew. Table 73 shows ATA timing parameters.

Table 73. PATA Timing Parameters

Name	Description	Value/ Contributing Factor ¹
T	Bus clock period (AHB_CLK_ROOT)	Peripheral clock frequency (7.5 ns for 133 MHz clock)
ti_ds	Set-up time ata_data to ata_iordy edge (UDMA-in only) UDMA0 UDMA1 UDMA2, UDMA3 UDMA4 UDMA5	15 ns 10 ns 7 ns 5 ns 4 ns
ti_dh	Hold time ata_iordy edge to ata_data (UDMA-in only) UDMA0, UDMA1, UDMA2, UDMA3, UDMA4 UDMA5	5.0 ns 4.6 ns
tco	Propagation delay bus clock L-to-H to ata_cs0, ata_cs1, ata_da2, ata_da1, ata_da0, ata_dior, ata_diow, ata_dmack, ata_data, ata_buffer_en	12.0 ns
tsu	Set-up time ata_data to bus clock L-to-H	8.5 ns
tsui	Set-up time ata_iordy to bus clock H-to-L	8.5 ns
thi	Hold time ata_iordy to bus clock H to L	2.5 ns
tskew1	Max difference in propagation delay bus clock L-to-H to any of following signals ata_cs0, ata_cs1, ata_da2, ata_da1, ata_da0, ata_dior, ata_diow, ata_dmack, ata_data (write), ata_buffer_en	7 ns
tskew2	Max difference in buffer propagation delay for any of following signals: ata_cs0, ata_cs1, ata_da2, ata_da1, ata_da0, ata_dior, ata_diow, ata_dmack, ata_data (write), ata_buffer_en	Transceiver
tskew3	Max difference in buffer propagation delay for any of following signals ata_iordy, ata_data (read)	Transceiver
tbuf	Max buffer propagation delay	Transceiver
tcable1	Cable propagation delay for ata_data	Cable
tcable2	Cable propagation delay for control signals ata_dior, ata_diow, ata_iordy, ata_dmack	Cable
tskew4	Max difference in cable propagation delay between ata_iordy and ata_data (read)	Cable
tskew5	Max difference in cable propagation delay between (ata_dior, ata_diow, ata_dmack) and ata_cs0, ata_cs1, ata_da2, ata_da1, ata_da0, ata_data(write)	Cable
tskew6	Max difference in cable propagation delay without accounting for ground bounce	Cable

¹ Values provided where applicable.

4.7.12.1 PIO Mode Read Timing

Figure 64 shows timing for PIO read. Table 74 lists the timing parameters for PIO read.

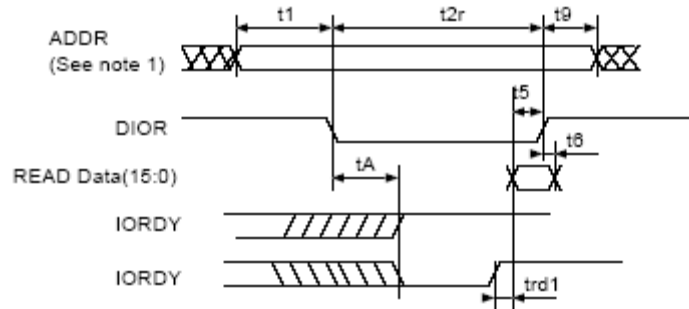

Figure 64. PIO Read Timing Diagram

Table 74. PIO Read Timing Parameters

ATA Parameter	Parameter from Figure 64	Value	Controlling Variable
t1	t1	$t1(\min) = \text{time_1} \times T - (\text{tskew1} + \text{tskew2} + \text{tskew5})$	time_1
t2 (read)	t2r	$t2(\min) = \text{time_2r} \times T - (\text{tskew1} + \text{tskew2} + \text{tskew5})$	time_2r
t9	t9	$t9(\min) = \text{time_9} \times T - (\text{tskew1} + \text{tskew2} + \text{tskew6})$	time_9
t5	t5	$t5(\min) = \text{tco} + \text{tsu} + \text{tbuf} + \text{tbuf} + \text{tcable1} + \text{tcable2}$	time_2 (affects tsu and tco)
t6	t6	0	—
tA	tA	$tA(\min) = (1.5 + \text{time_ax}) \times T - (\text{tco} + \text{tsui} + \text{tcable2} + \text{tcable2} + 2 \times \text{tbuf})$	time_ax
trd	trd1	$\text{trd1}(\max) = (-\text{trd}) + (\text{tskew3} + \text{tskew4})$ $\text{trd1}(\min) = (\text{time_pio_rdx} - 0.5) \times T - (\text{tsu} + \text{thi})$ $(\text{time_pio_rdx} - 0.5) \times T > \text{tsu} + \text{thi} + \text{tskew3} + \text{tskew4}$	time_pio_rdx
t0	—	$t0(\min) = (\text{time_1} + \text{time_2r} + \text{time_9}) \times T$	time_1, time_2r, time_9

Figure 65 shows timing for PIO write. Table 75 lists the timing parameters for PIO write.

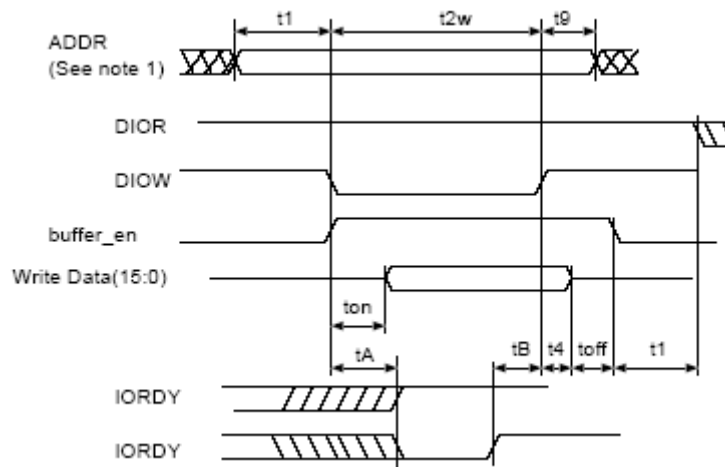

Figure 65. Multi-word DMA (MDMA) Timing

Table 75. PIO Write Timing Parameters

ATA Parameter	Parameter from Figure 65	Value	Controlling Variable
t_1	t_1	$t_1(\min) = \text{time_1} \times T - (\text{tskew1} + \text{tskew2} + \text{tskew5})$	time_1
t_2 (write)	t_{2w}	$t_2(\min) = \text{time_2w} \times T - (\text{tskew1} + \text{tskew2} + \text{tskew5})$	time_2w
t_9	t_9	$t_9(\min) = \text{time_9} \times T - (\text{tskew1} + \text{tskew2} + \text{tskew6})$	time_9
t_3	—	$t_3(\min) = (\text{time_2w} - \text{time_on}) \times T - (\text{tskew1} + \text{tskew2} + \text{tskew5})$	If not met, increase time_2w
t_4	t_4	$t_4(\min) = \text{time_4} \times T - \text{tskew1}$	time_4
t_A	t_A	$t_A = (1.5 + \text{time_ax}) \times T - (\text{tco} + \text{tsui} + \text{tcable2} + \text{tcable2} + 2 \times \text{tbuf})$	time_ax
t_0	—	$t_0(\min) = (\text{time_1} + \text{time_2} + \text{time_9}) \times T$	time_1 , time_2r , time_9
—	—	Avoid bus contention when switching buffer on by making t_{on} long enough	—
—	—	Avoid bus contention when switching buffer off by making t_{off} long enough	—

Electrical Characteristics

Figure 66 shows timing for MDMA read, Figure 67 shows timing for MDMA write, and Table 76 lists the timing parameters for MDMA read and write.

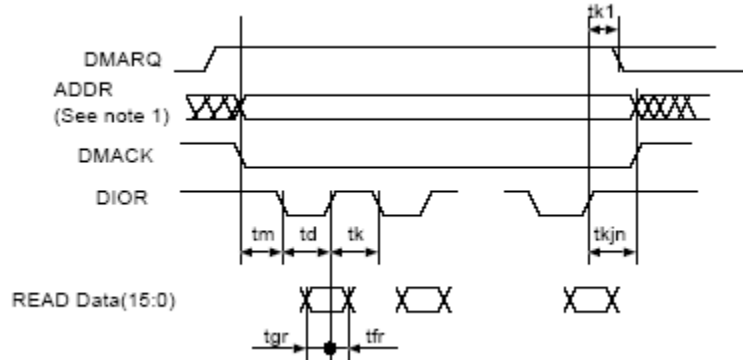

Figure 66. MDMA Read Timing Diagram

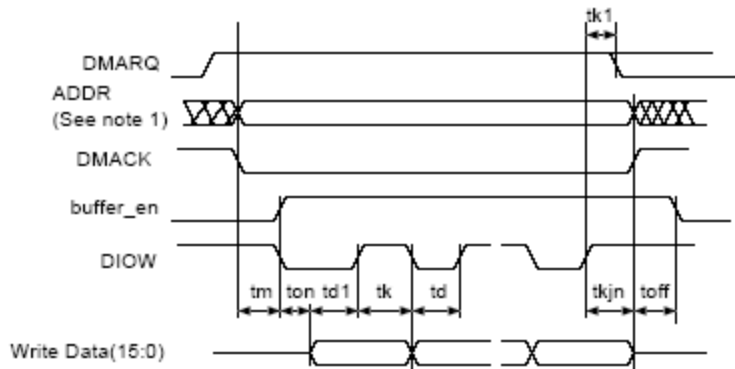

Figure 67. MDMA Write Timing Diagram

Table 76. MDMA Read and Write Timing Parameters

ATA Parameter	Parameter from Figure 66 (Read), Figure 67 (Write)	Value	Controlling Variable
tm, ti	tm	$tm(\min) = ti(\min) = time_m \times T - (tskew1 + tskew2 + tskew5)$	time_m
td	td, td1	$td1(\min) = td(\min) = time_d \times T - (tskew1 + tskew2 + tskew6)$	time_d
tk	tk ¹	$tk(\min) = time_k \times T - (tskew1 + tskew2 + tskew6)$	time_k
t0	—	$t0(\min) = (time_d + time_k) \times T$	time_d, time_k
tg(read)	tgr	$tgr(\min-read) = tco + tsu + tbuf + tbuf + tcable1 + tcable2$ $tgr(\min-drive) = td - te(drive)$	time_d
tf(read)	tfr	$tfr(\min) = 5\text{ ns}$	—
tg(write)	—	$tg(\min-write) = time_d \times T - (tskew1 + tskew2 + tskew5)$	time_d
tf(write)	—	$tf(\min-write) = time_k \times T - (tskew1 + tskew2 + tskew6)$	time_k
tL	—	$tL(\max) = (time_d + time_k - 2) \times T - (tsu + tco + 2 \times tbuf + 2 \times tcable2)$	time_d, time_k ²

Table 76. MDMA Read and Write Timing Parameters (continued)

ATA Parameter	Parameter from Figure 66 (Read), Figure 67 (Write)	Value	Controlling Variable
t_n, t_j	t_{kjn}	$t_n = t_j = t_{kjn} = \text{time_jn} \times T - (\text{tskew1} + \text{tskew2} + \text{tskew6})$	time_jn
—	t_{on} t_{off}	$t_{on} = \text{time_on} \times T - \text{tskew1}$ $t_{off} = \text{time_off} \times T - \text{tskew1}$	—

¹ t_{k1} in the MDMA figures (Figure 66 and Figure 67) equals $(t_k - 2 \times T)$.

² t_{k1} in the MDMA figures equals $(t_k - 2 \times T)$.

4.7.12.2 Ultra DMA (UDMA) Input Timing

Figure 68 shows timing when the UDMA in transfer starts, Figure 69 shows timing when the UDMA in host terminates transfer, Figure 70 shows timing when the UDMA in device terminates transfer, and Table 77 lists the timing parameters for UDMA in burst.

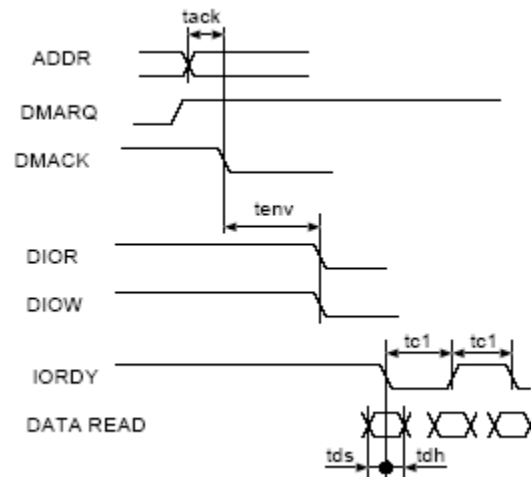

Figure 68. UDMA in Transfer Starts Timing Diagram

Electrical Characteristics

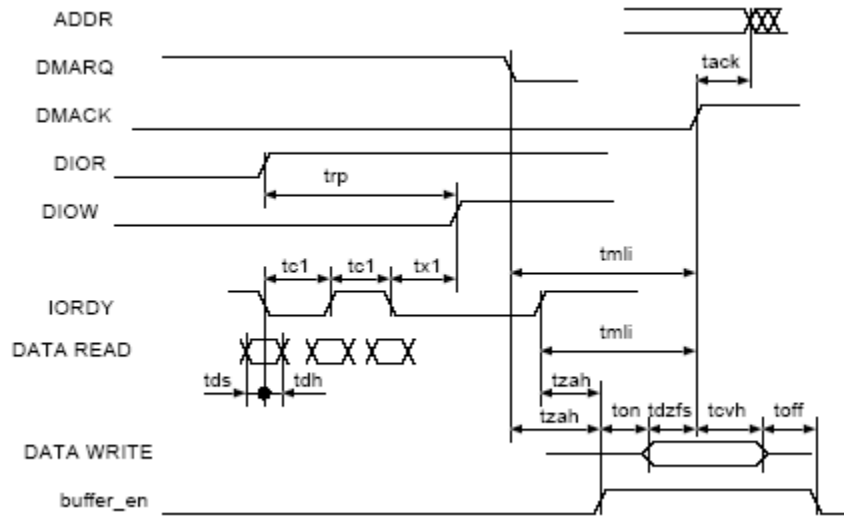

Figure 69. UDMA in Host Terminates Transfer Timing Diagram

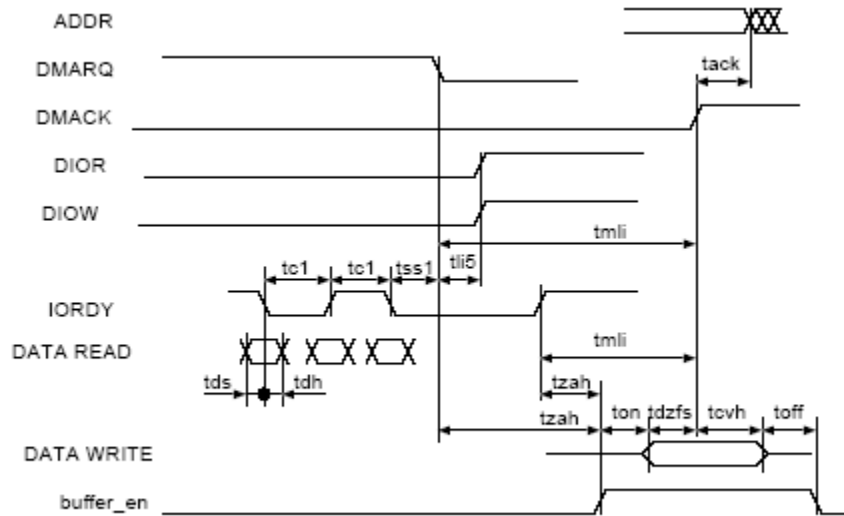

Figure 70. UDMA in Device Terminates Transfer Timing Diagram

Table 77. UDMA in Burst Timing Parameters

ATA Parameter	Parameter from Figure 68, Figure 69, and Figure 70	Description	Controlling Variable
tack	tack	$tack (min) = (time_ack \times T) - (tskew1 + tskew2)$	time_ack
tenv	tenv	$tenv (min) = (time_env \times T) - (tskew1 + tskew2)$ $tenv (max) = (time_env \times T) + (tskew1 + tskew2)$	time_env
tds	tds1	$tds - (tskew3) - ti_ds > 0$	tskew3, ti_ds, ti_dh should be low enough
tdh	tdh1	$tdh - (tskew3) - ti_dh > 0$	

Table 77. UDMA in Burst Timing Parameters (continued)

ATA Parameter	Parameter from Figure 68, Figure 69, and Figure 70	Description	Controlling Variable
tcyc	tc1	$(tcyc - tskew) > T$	T big enough
trp	trp	$trp \text{ (min)} = time_rp \times T - (tskew1 + tskew2 + tskew6)$	time_rp
—	tx1 ¹	$(time_rp \times T) - (tco + tsu + 3T + 2 \times tbuf + 2 \times tcable2) > trfs \text{ (drive)}$	time_rp
tmli	tmli1	$tmli1 \text{ (min)} = (time_mlix + 0.4) \times T$	time_mlix
tzah	tzah	$tzah \text{ (min)} = (time_zah + 0.4) \times T$	time_zah
tdzfs	tdzfs	$tdzfs = (time_dzfs \times T) - (tskew1 + tskew2)$	time_dzfs
tcvh	tcvh	$tcvh = (time_cvh \times T) - (tskew1 + tskew2)$	time_cvh
—	ton toff ²	ton = time_on \times T - tskew1 toff = time_off \times T - tskew1	—

¹ There is a special timing requirement in the ATA host that requires the internal DIOW to go only high 3 clocks after the last active edge on the DSTROBE signal. The equation given on this line tries to capture this constraint.

² Make ton and toff big enough to avoid bus contention.

4.7.12.3 UDMA Output Timing

Figure 71 shows timing when the UDMA out transfer starts, Figure 72 shows timing when the UDMA out host terminates transfer, Figure 73 shows timing when the UDMA out device terminates transfer, and Table 78 lists the timing parameters for UDMA out burst.

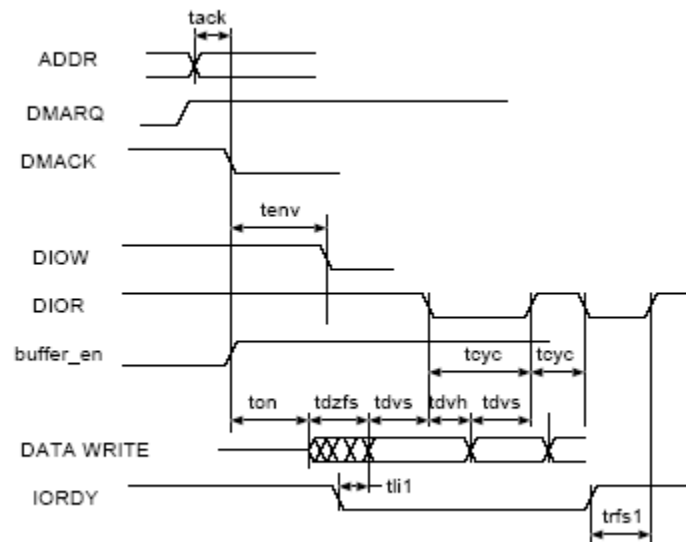

Figure 71. UDMA Out Transfer Starts Timing Diagram

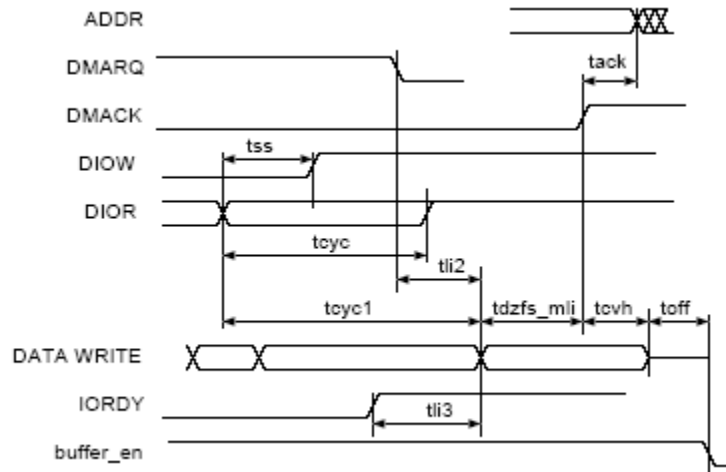

Figure 72. UDMA Out Host Terminates Transfer Timing Diagram

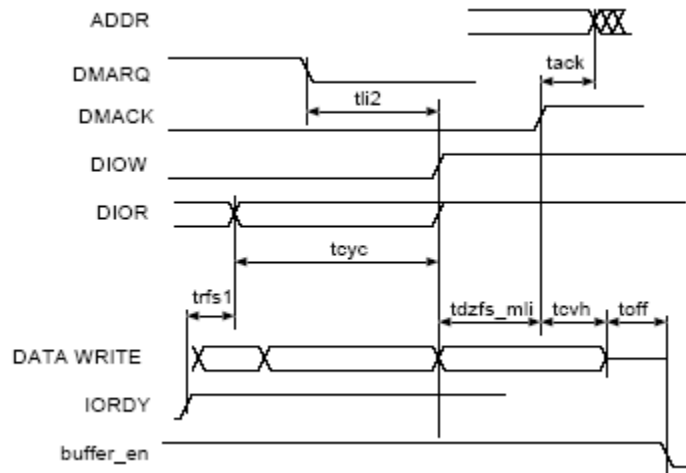

Figure 73. UDMA Out Device Terminates Transfer Timing Diagram

Table 78. UDMA Out Burst Timing Parameters

ATA Parameter	Parameter from Figure 71, Figure 72, Figure 73	Value	Controlling Variable
tack	tack	$tack (min) = (time_ack \times T) - (tskew1 + tskew2)$	time_ack
tenv	tenv	$tenv (min) = (time_env \times T) - (tskew1 + tskew2)$ $tenv (max) = (time_env \times T) + (tskew1 + tskew2)$	time_env
tdvs	tdvs	$tdvs = (time_dvs \times T) - (tskew1 + tskew2)$	time_dvs
tdvh	tdvh	$tdvh = (time_dvh \times T) - (tskew1 + tskew2)$	time_dvh
tcyc	tcyc	$tcyc = time_cyc \times T - (tskew1 + tskew2)$	time_cyc
t2cyc	—	$t2cyc = time_cyc \times 2 \times T$	time_cyc

Table 78. UDMA Out Burst Timing Parameters (continued)

ATA Parameter	Parameter from Figure 71, Figure 72, Figure 73	Value	Controlling Variable
trfs1	trfs	$trfs = 1.6 \times T + tsui + tco + tbuf + tbuf$	—
—	tdzfs	$tdzfs = time_dzfs \times T - (tskew1)$	time_dzfs
tss	tss	$tss = time_ss \times T - (tskew1 + tskew2)$	time_ss
tmli	tdzfs_mli	$tdzfs_mli = \max(time_dzfs, time_mli) \times T - (tskew1 + tskew2)$	—
tli	tli1	$tli1 > 0$	—
tli	tli2	$tli2 > 0$	—
tli	tli3	$tli3 > 0$	—
tcvh	tcvh	$tcvh = (time_cvh \times T) - (tskew1 + tskew2)$	time_cvh
—	ton toff	$ton = time_on \times T - tskew1$ $toff = time_off \times T - tskew1$	—

4.7.13 SATA PHY Parameters

This section describes SATA PHY electrical specifications.

4.7.13.1 Reference Clock Electrical and Jitter Specifications

The refclk signal is differential and supports frequencies of 25 MHz or 50-156.25 MHz (100 MHz and 125 MHz are common frequencies). The frequency is pin-selectable (for more information about the signal, see “Per-Transceiver Control and Status Signals” in the SATA PHY chapter in the Reference Manual).

Table 79 provides the SATA PHY reference clock specifications.

Table 79. Reference Clock Specifications

Parameters	Test Conditions	Min	Max	Unit
Differential peak voltage (typically 0.71 V)	—	350	850	mV
Common mode voltage (refclk_p + refclk_m) / 2	—	175	2,000	mV
Total phase jitter	For information about total phase jitter, see following section	—	3	ps RMS
Minimum/maximum duty cycle	—	40	60	% UI
Frequency range	—	25	156.25	MHz

4.7.13.1.1 Reference Clock Jitter Measurement

The total phase jitter on the reference clock is specified at 3 ps RMS. There are numerous ways to measure the reference clock jitter, one of which is as follows.

Using a high-speed sampling scope (20 GSamples/s), 1 million samples of the differential reference clock are taken, and the zero-crossing times of each rising edge are calculated. From the zero-crossing data, an average reference clock period is calculated. This average reference clock period is subtracted from each sequential, instantaneous period to find the difference between each reference clock rising edge and the ideal placement to produce the phase jitter sequence. The power spectral density (PSD) of the phase jitter is calculated and integrated after being weighted with the transfer function shown in Figure 74. The square root of the resultant integral is the RMS total phase jitter.

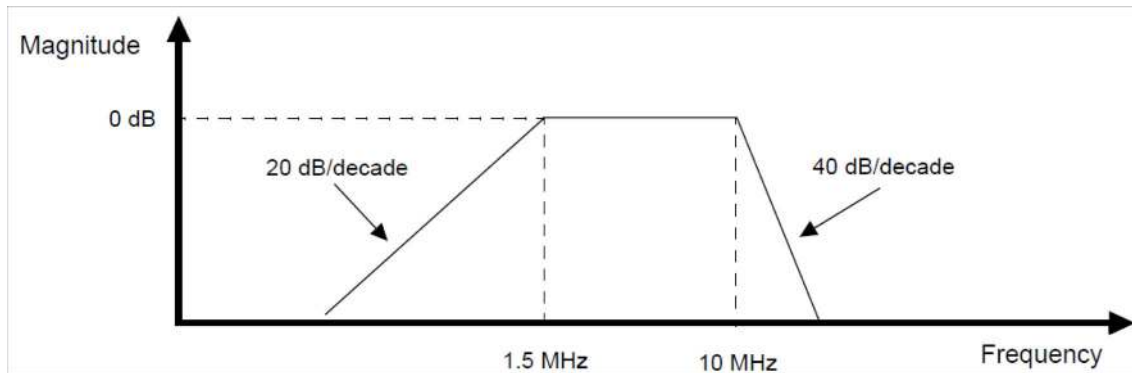

Figure 74. Weighting Function for RMS Phase Jitter Calculation

4.7.13.2 Transmitter and Receiver Characteristics

The SATA PHY meets or exceeds the electrical compliance requirements defined in the SATA specification. The following subsections provide values obtained from a combination of simulations and silicon characterization.

NOTE

The tables in the following sections indicate any exceptions to the SATA specification or aspects of the SATA PHY that exceed the standard, as well as provide information about parameters not defined in the standard.

4.7.13.2.1 SATA PHY Transmitter Characteristics

Table 80 provides specifications for SATA PHY transmitter characteristics.

Table 80. SATA2 PHY Transmitter Characteristics

Parameters	Symbol	Min	Typ	Max	Unit
Transmit common mode voltage	V_{CTM}	0.4	—	0.6	V
Transmitter pre-emphasis accuracy (measured change in de-emphasized bit)	—	-0.5	—	0.5	dB

4.7.13.2.2 SATA PHY Receiver Characteristics

Table 81 provides specifications for SATA PHY receiver characteristics.

Table 81. SATA PHY Receiver Characteristics

Parameters	Symbol	Min	Typ	Max	Unit
Minimum Rx eye height (differential peak-to-peak)	$V_{\text{MIN_RX_EYE_HEIGHT}}$	—	—	175	mV
Tolerance	PPM	-400	—	400	ppm

4.7.13.3 SATA_REXT Reference Resistor Connection

The impedance calibration process requires connection of reference resistor 191 Ω . 1% precision resistor on SATA_REXT pad to ground.

Resistor calibration consists of learning which state of the internal Resistor Calibration register causes an internal, digitally trimmed calibration resistor to best match the impedance applied to the SATA_REXT pin. The calibration register value is then supplied to all Tx and Rx termination resistors.

During the calibration process (for a few tens of microseconds), up to 0.3 mW can be dissipated in the external SATA_REXT resistor. At other times, no power is dissipated by the SATA_REXT resistor.

4.7.13.4 SATA Connectivity When Not in Use

NOTE

The Temperature Sensor is part of the SATA module. If SATA IP is disabled, the Temperature Sensor will not work as well. Temperature Sensor functionality is important in supporting high performance applications without overheating the device (at high ambient temp).

When both SATA and thermal sensor are not required, connect VP and VPH supplies to ground. The rest of the ports, both inputs and outputs (SATA_REFCLKM, SATA_REFCLKP, SATA_REXT, SATA_RXM, SATA_RXP, SATA_TXM) can be left floating. It is not recommended to turn off the VPH while the VP is active.

When SATA is not in use but thermal sensor is still required, both VP and VPH supplies must be powered on according to their nominal voltage levels. The reference clock input frequency must fall within the specified range of 25 MHz to 156.25 MHz. SATA_REXT does not need to be connected, as the termination impedance is not of consequence.

4.7.14 SCAN JTAG Controller (SJC) Timing Parameters

Figure 75 depicts the SJC test clock input timing. Figure 76 depicts the SJC boundary scan timing. Figure 77 depicts the SJC test access port. Signal parameters are listed in Table 82.

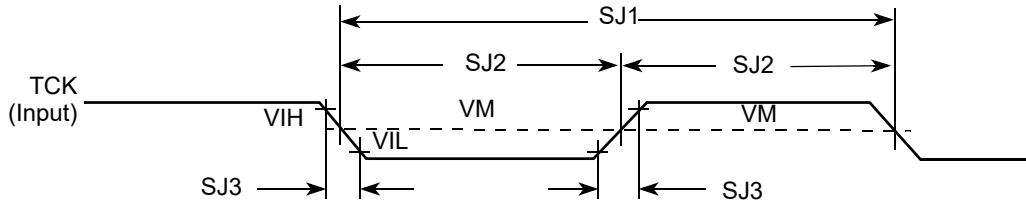

Figure 75. Test Clock Input Timing Diagram

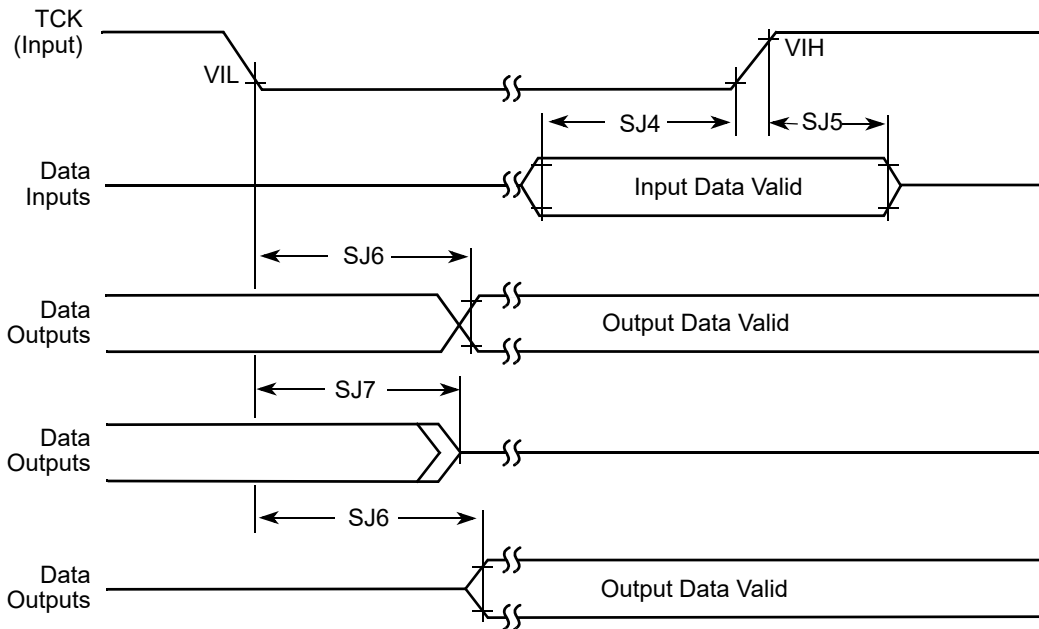

Figure 76. Boundary Scan (JTAG) Timing Diagram

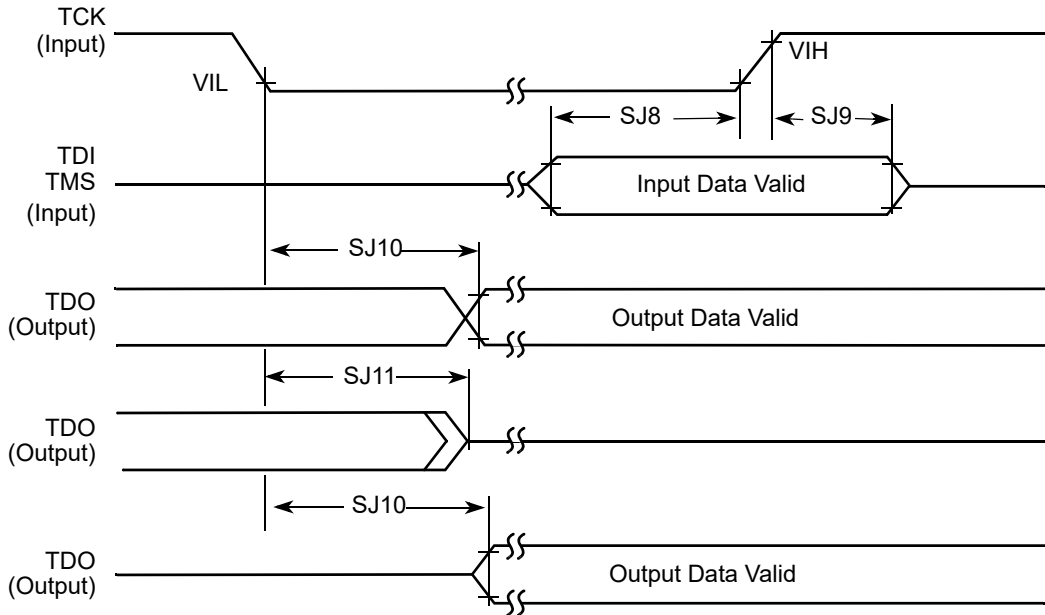

Figure 77. Test Access Port Timing Diagram

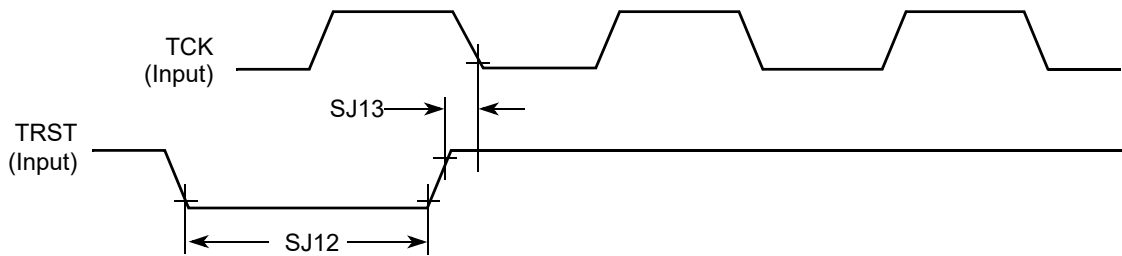

Figure 78. TRST Timing Diagram

Table 82. JTAG Timing

ID	Parameter ^{1,2}	All Frequencies		Unit
		Min	Max	
SJ0	TCK frequency of operation $1/(3 \cdot T_{DC})^1$	0.001	22	MHz
SJ1	TCK cycle time in crystal mode	45	—	ns
SJ2	TCK clock pulse width measured at V_M^2	22.5	—	ns
SJ3	TCK rise and fall times	—	3	ns
SJ4	Boundary scan input data set-up time	5	—	ns
SJ5	Boundary scan input data hold time	24	—	ns
SJ6	TCK low to output data valid	—	40	ns
SJ7	TCK low to output high impedance	—	40	ns
SJ8	TMS, TDI data set-up time	5	—	ns

Table 82. JTAG Timing (continued)

ID	Parameter ^{1,2}	All Frequencies		Unit
		Min	Max	
SJ9	TMS, TDI data hold time	25	—	ns
SJ10	TCK low to TDO data valid	—	44	ns
SJ11	TCK low to TDO high impedance	—	44	ns
SJ12	$\overline{\text{TRST}}$ assert time	100	—	ns
SJ13	$\overline{\text{TRST}}$ set-up time to TCK low	40	—	ns

¹ T_{DC} = target frequency of SJC

² V_M = mid-point voltage

4.7.15 SPDIF Timing Parameters

The Sony/Philips Digital Interconnect Format (SPDIF) data is sent using the bi-phase marking code. When encoding, the SPDIF data signal is modulated by a clock that is twice the bit rate of the data signal.

Table 83 and Figures , show SPDIF timing parameters for the Sony/Philips Digital Interconnect Format (SPDIF), including the timing of the modulating Rx clock (SRCK) for SPDIF in Rx mode and the timing of the modulating Tx clock (STCLK) for SPDIF in Tx mode.

Table 83. SPDIF Timing Parameters

Characteristics	Symbol	Timing Parameter Range		Units
		Min	Max	
SPDIFIN Skew: asynchronous inputs, no specs apply	—	—	0.7	ns
SPDIFOUT output (Load = 50pf)	—	—	1.5	ns
• Skew	—	—	24.2	
• Transition rising	—	—	31.3	
• Transition falling	—	—	—	
SPDIFOUT1 output (Load = 30pf)	—	—	1.5	ns
• Skew	—	—	13.6	
• Transition rising	—	—	18.0	
• Transition falling	—	—	—	
Modulating Rx clock (SRCK) period	srckp	40.0	—	ns
SRCK high period	srckph	16.0	—	ns
SRCK low period	srckpl	16.0	—	ns
Modulating Tx clock (STCLK) period	stclkp	40.0	—	ns
STCLK high period	stclkph	16.0	—	ns
STCLK low period	stclkpl	16.0	—	ns

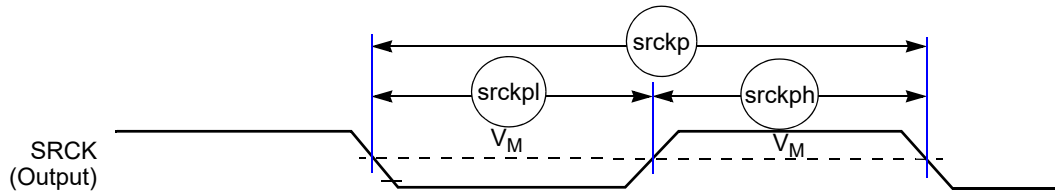

Figure 79. SPDIF Timing Diagram

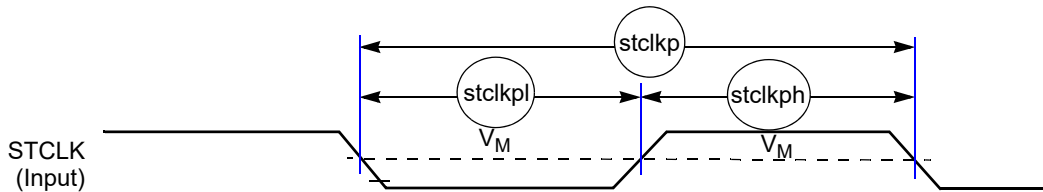

Figure 80. STCLK Timing

4.7.16 SSI Timing Parameters

This section describes the timing parameters of the SSI module. The connectivity of the serial synchronous interfaces are summarized in [Table 84](#).

Table 84. AUDMUX Port Allocation

Port	Signal Nomenclature	Type and Access
AUDMUX port 1	SSI 1	Internal
AUDMUX port 2	SSI 2	Internal
AUDMUX port 3	AUD3	External— AUD3 I/O
AUDMUX port 4	AUD4	External— EIM or CSPI1 I/O through IOMUXC
AUDMUX port 5	AUD5	External— EIM or SD1 I/O through IOMUXC
AUDMUX port 6	AUD6	External— EIM or DISP2 through IOMUXC
AUDMUX port 7	SSI 3	Internal

NOTE

- The terms WL and BL used in the timing diagrams and tables refer to Word Length (WL) and Bit Length (BL).
- The SSI timing diagrams use generic signal names wherein the names used in the i.MX53 Reference Manual are channel specific signal names. For example, a channel clock referenced in the IOMUXC chapter as AUD3_TXC appears in the timing diagram as TXC.

4.7.16.1 SSI Transmitter Timing with Internal Clock

Figure 81 depicts the SSI transmitter internal clock timing and Table 85 lists the timing parameters for the SSI transmitter internal clock.

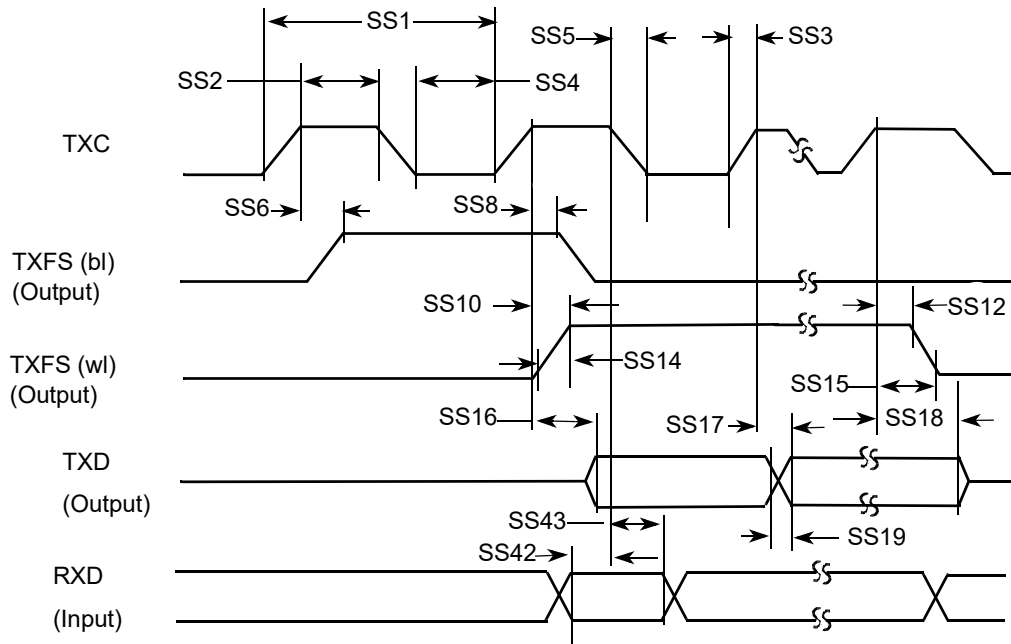

Note: SRXD input in synchronous mode only
 : SRXD input in synchronous mode only

Figure 81. SSI Transmitter Internal Clock Timing Diagram

Table 85. SSI Transmitter Timing with Internal Clock

ID	Parameter	Min	Max	Unit
Internal Clock Operation				
SS1	(Tx/Rx) CK clock period	81.4	—	ns
SS2	(Tx/Rx) CK clock high period	36.0	—	ns
SS3	(Tx/Rx) CK clock rise time	—	6.0	ns
SS4	(Tx/Rx) CK clock low period	36.0	—	ns
SS5	(Tx/Rx) CK clock fall time	—	6.0	ns
SS6	(Tx) CK high to FS (bl) high	—	15.0	ns
SS8	(Tx) CK high to FS (bl) low	—	15.0	ns
SS10	(Tx) CK high to FS (wl) high	—	15.0	ns
SS12	(Tx) CK high to FS (wl) low	—	15.0	ns
SS14	(Tx/Rx) Internal FS rise time	—	6.0	ns
SS15	(Tx/Rx) Internal FS fall time	—	6.0	ns
SS16	(Tx) CK high to STXD valid from high impedance	—	15.0	ns

Table 85. SSI Transmitter Timing with Internal Clock (continued)

ID	Parameter	Min	Max	Unit
SS17	(Tx) CK high to STXD high/low	—	15.0	ns
SS18	(Tx) CK high to STXD high impedance	—	15.0	ns
SS19	STXD rise/fall time	—	6.0	ns
Synchronous Internal Clock Operation				
SS42	SRXD setup before (Tx) CK falling	10.0	—	ns
SS43	SRXD hold after (Tx) CK falling	0.0	—	ns
SS52	Loading	—	25.0	pF

NOTE

- All the timings for the SSI are given for a non-inverted serial clock polarity (TSCKP/RSCKP = 0) and a non-inverted frame sync (TFSI/RFSI = 0). If the polarity of the clock and/or the frame sync have been inverted, all the timing remains valid by inverting the clock signal STCK/SRCK and/or the frame sync STFS/SRFS shown in the tables and in the figures.
- All timings are on Audiomux Pads when SSI is being used for data transfer.
- The terms WL and BL refer to Word Length (WL) and Bit Length (BL).
- “Tx” and “Rx” refer to the Transmit and Receive sections of the SSI.
- For internal Frame Sync operation using external clock, the FS timing is same as that of Tx Data (for example, during AC97 mode of operation).

4.7.16.2 SSI Receiver Timing with Internal Clock

Figure 82 depicts the SSI receiver internal clock timing and Table 86 lists the timing parameters for the receiver timing with the internal clock

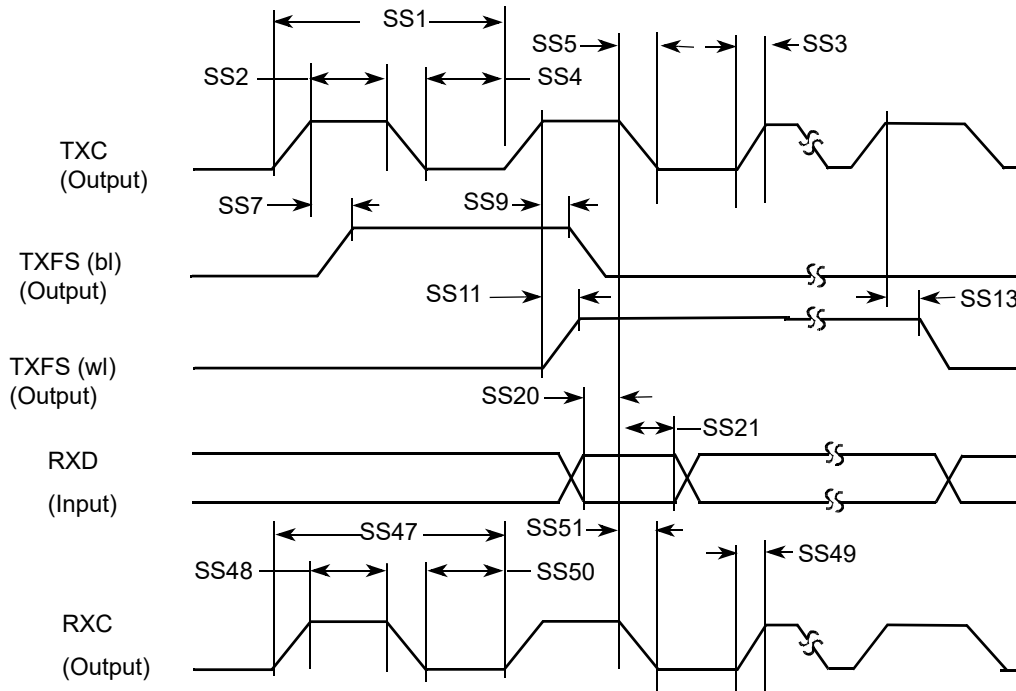

Figure 82. SSI Receiver Internal Clock Timing Diagram

Table 86. SSI Receiver Timing with Internal Clock

ID	Parameter	Min	Max	Unit
Internal Clock Operation				
SS1	(Tx/Rx) CK clock period	81.4	—	ns
SS2	(Tx/Rx) CK clock high period	36.0	—	ns
SS3	(Tx/Rx) CK clock rise time	—	6.0	ns
SS4	(Tx/Rx) CK clock low period	36.0	—	ns
SS5	(Tx/Rx) CK clock fall time	—	6.0	ns
SS7	(Rx) CK high to FS (bl) high	—	15.0	ns
SS9	(Rx) CK high to FS (bl) low	—	15.0	ns
SS11	(Rx) CK high to FS (wl) high	—	15.0	ns
SS13	(Rx) CK high to FS (wl) low	—	15.0	ns
SS20	SRXD setup time before (Rx) CK low	10.0	—	ns
SS21	SRXD hold time after (Rx) CK low	0.0	—	ns

Table 86. SSI Receiver Timing with Internal Clock (continued)

ID	Parameter	Min	Max	Unit
Oversampling Clock Operation				
SS47	Oversampling clock period	15.04	—	ns
SS48	Oversampling clock high period	6.0	—	ns
SS49	Oversampling clock rise time	—	3.0	ns
SS50	Oversampling clock low period	6.0	—	ns
SS51	Oversampling clock fall time	—	3.0	ns

NOTE

- All the timings for the SSI are given for a non-inverted serial clock polarity (TSCKP/RSCKP = 0) and a non-inverted frame sync (TFSI/RFSI = 0). If the polarity of the clock and/or the frame sync have been inverted, all the timing remains valid by inverting the clock signal STCK/SRCK and/or the frame sync STFS/SRFS shown in the tables and in the figures.
- All timings are on Audiomux Pads when SSI is being used for data transfer.
- “Tx” and “Rx” refer to the Transmit and Receive sections of the SSI.
- The terms WL and BL refer to Word Length (WL) and Bit Length (BL).
- For internal Frame Sync operation using external clock, the FS timing is same as that of Tx Data (for example, during AC97 mode of operation).

4.7.16.3 SSI Transmitter Timing with External Clock

Figure 83 depicts the SSI transmitter external clock timing and Table 87 lists the timing parameters for the transmitter timing with the external clock

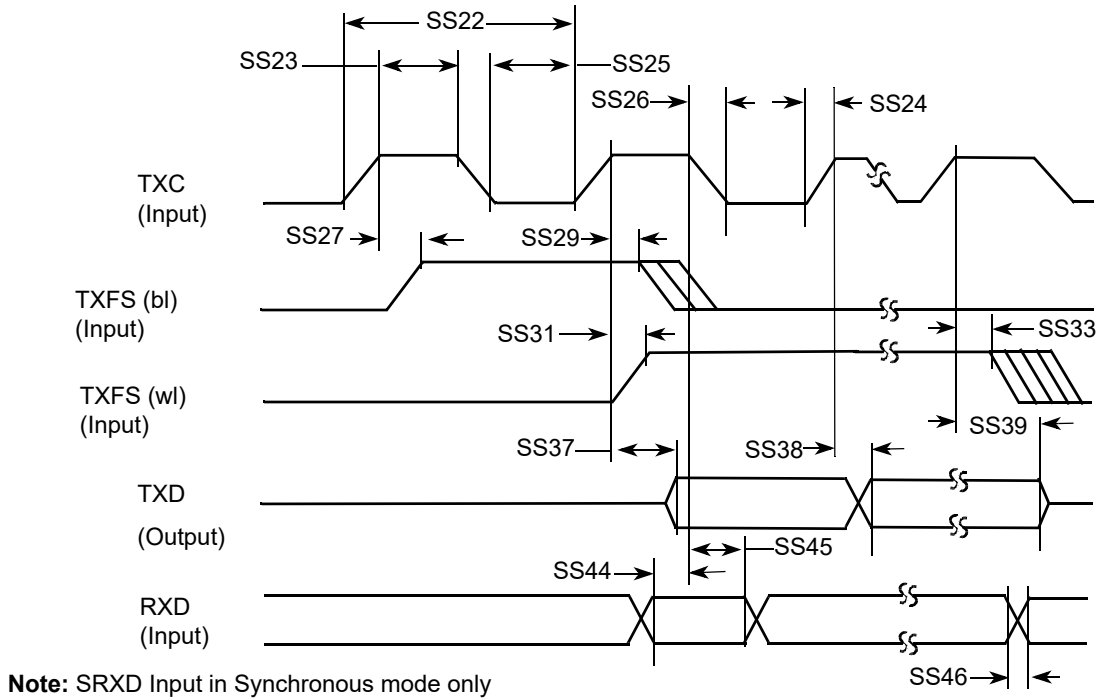

Figure 83. SSI Transmitter External Clock Timing Diagram

Table 87. SSI Transmitter Timing with External Clock

ID	Parameter	Min	Max	Unit
External Clock Operation				
SS22	(Tx/Rx) CK clock period	81.4	—	ns
SS23	(Tx/Rx) CK clock high period	36.0	—	ns
SS24	(Tx/Rx) CK clock rise time	—	6.0	ns
SS25	(Tx/Rx) CK clock low period	36.0	—	ns
SS26	(Tx/Rx) CK clock fall time	—	6.0	ns
SS27	(Tx) CK high to FS (bl) high	-10.0	15.0	ns
SS29	(Tx) CK high to FS (bl) low	10.0	—	ns
SS31	(Tx) CK high to FS (wl) high	-10.0	15.0	ns
SS33	(Tx) CK high to FS (wl) low	10.0	—	ns
SS37	(Tx) CK high to STXD valid from high impedance	—	15.0	ns
SS38	(Tx) CK high to STXD high/low	—	15.0	ns

Table 87. SSI Transmitter Timing with External Clock (continued)

ID	Parameter	Min	Max	Unit
SS39	(Tx) CK high to STXD high impedance	—	15.0	ns
Synchronous External Clock Operation				
SS44	SRXD setup before (Tx) CK falling	10.0	—	ns
SS45	SRXD hold after (Tx) CK falling	2.0	—	ns
SS46	SRXD rise/fall time	—	6.0	ns

NOTE

- All the timings for the SSI are given for a non-inverted serial clock polarity (TSCKP/RSCCKP = 0) and a non-inverted frame sync (TFSI/RFSI = 0). If the polarity of the clock and/or the frame sync have been inverted, all the timing remains valid by inverting the clock signal STCK/SRCK and/or the frame sync STFS/SRFS shown in the tables and in the figures.
- All timings are on Audiomux Pads when SSI is being used for data transfer.
- “Tx” and “Rx” refer to the Transmit and Receive sections of the SSI.
- The terms WL and BL refer to Word Length (WL) and Bit Length (BL).
- For internal Frame Sync operation using external clock, the FS timing is same as that of Tx Data (for example, during AC97 mode of operation).

4.7.16.4 SSI Receiver Timing with External Clock

Figure 84 depicts the SSI receiver external clock timing and Table 88 lists the timing parameters for the receiver timing with the external clock.

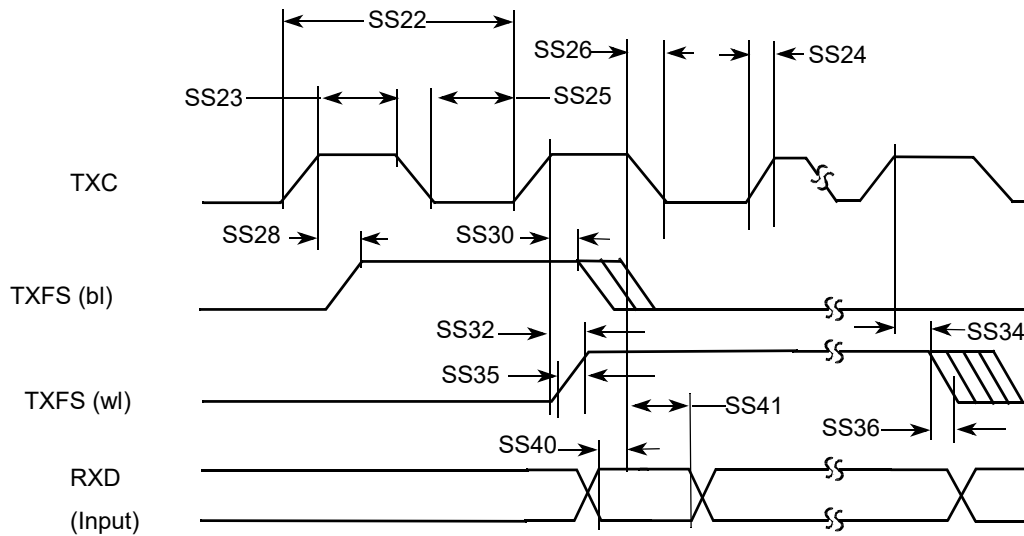

Figure 84. SSI Receiver External Clock Timing Diagram

Table 88. SSI Receiver Timing with External Clock

ID	Parameter	Min	Max	Unit
External Clock Operation				
SS22	(Tx/Rx) CK clock period	81.4	—	ns
SS23	(Tx/Rx) CK clock high period	36	—	ns
SS24	(Tx/Rx) CK clock rise time	—	6.0	ns
SS25	(Tx/Rx) CK clock low period	36	—	ns
SS26	(Tx/Rx) CK clock fall time	—	6.0	ns
SS28	(Rx) CK high to FS (bl) high	-10	15.0	ns
SS30	(Rx) CK high to FS (bl) low	10	—	ns
SS32	(Rx) CK high to FS (wl) high	-10	15.0	ns
SS34	(Rx) CK high to FS (wl) low	10	—	ns
SS35	(Tx/Rx) External FS rise time	—	6.0	ns
SS36	(Tx/Rx) External FS fall time	—	6.0	ns
SS40	SRXD setup time before (Rx) CK low	10	—	ns
SS41	SRXD hold time after (Rx) CK low	2	—	ns

NOTE

- All the timings for the SSI are given for a non-inverted serial clock polarity (TSCKP/RSCKP = 0) and a non-inverted frame sync (TFSI/RFSI = 0). If the polarity of the clock and/or the frame sync have been inverted, all the timing remains valid by inverting the clock signal STCK/SRCK and/or the frame sync STFS/SRFS shown in the tables and in the figures.
- All timings are on Audiomux Pads when SSI is being used for data transfer.
- “Tx” and “Rx” refer to the Transmit and Receive sections of the SSI.
- The terms WL and BL refer to Word Length (WL) and Bit Length (BL).
- For internal Frame Sync operation using external clock, the FS timing is same as that of Tx Data (for example, during AC97 mode of operation).

4.7.17 UART I/O Configuration and Timing Parameters

4.7.17.1 UART RS-232 I/O Configuration in Different Modes

The i.MX53 UART interfaces can serve both as DTE or DCE device. This can be configured by the DCEDTE control bit (default 0 — DCE mode). [Table 89](#) shows the UART I/O configuration based on the enabled mode.

Table 89. UART I/O Configuration vs. Mode

Port	DTE Mode		DCE Mode	
	Direction	Description	Direction	Description
RTS	Output	RTS from DTE to DCE	Input	RTS from DTE to DCE
CTS	Input	CTS from DCE to DTE	Output	CTS from DCE to DTE
DTR	Output	DTR from DTE to DCE	Input	DTR from DTE to DCE
DSR	Input	DSR from DCE to DTE	Output	DSR from DCE to DTE
DCD	Input	DCD from DCE to DTE	Output	DCD from DCE to DTE
RI	Input	RING from DCE to DTE	Output	RING from DCE to DTE
TXD_MUX	Input	Serial data from DCE to DTE	Output	Serial data from DCE to DTE
RXD_MUX	Output	Serial data from DTE to DCE	Input	Serial data from DTE to DCE

4.7.17.2 UART RS-232 Serial Mode Timing

The following sections describe the electrical information of the UART module in the RS-232 mode.

4.7.17.2.1 UART Transmitter

[Figure 85](#) depicts the transmit timing of UART in the RS-232 serial mode, with 8 data bit/1 stop bit format. [Table 90](#) lists the UART RS-232 serial mode transmit timing characteristics.

Electrical Characteristics

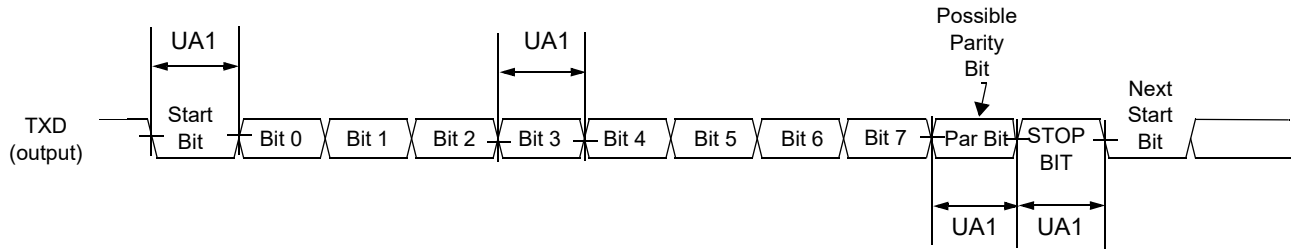

Figure 85. UART RS-232 Serial Mode Transmit Timing Diagram

Table 90. RS-232 Serial Mode Transmit Timing Parameters

ID	Parameter	Symbol	Min	Max	Units
UA1	Transmit Bit Time	t_{Tbit}	$\frac{1}{F_{baud_rate}} - \frac{1}{T_{ref_clk}}$	$\frac{1}{F_{baud_rate}} + \frac{1}{T_{ref_clk}}$	—

¹ F_{baud_rate} : Baud rate frequency. The maximum baud rate the UART can support is $(ipg_perclk \text{ frequency})/16$.

² T_{ref_clk} : The period of UART reference clock ref_clk (ipg_perclk after RFDIV divider).

4.7.17.2.2 UART Receiver

Figure 86 depicts the RS-232 serial mode receive timing with 8 data bit/1 stop bit format. Table 91 lists serial mode receive timing characteristics.

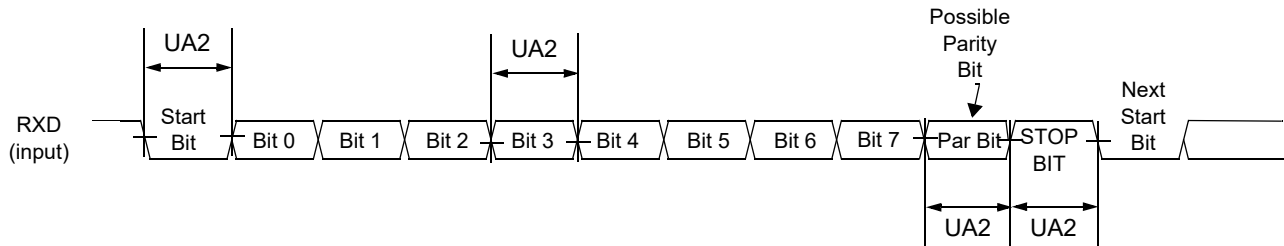

Figure 86. UART RS-232 Serial Mode Receive Timing Diagram

Table 91. RS-232 Serial Mode Receive Timing Parameters

ID	Parameter	Symbol	Min	Max	Units
UA2	Receive Bit Time ¹	t_{Rbit}	$\frac{1}{F_{baud_rate}} - \frac{1}{(16 \times F_{baud_rate})}$	$\frac{1}{F_{baud_rate}} + \frac{1}{(16 \times F_{baud_rate})}$	—

¹ The UART receiver can tolerate $1/(16 \times F_{baud_rate})$ tolerance in each bit. But accumulation tolerance in one frame must not exceed $3/(16 \times F_{baud_rate})$.

² F_{baud_rate} : Baud rate frequency. The maximum baud rate the UART can support is $(ipg_perclk \text{ frequency})/16$.

4.7.17.3 UART IrDA Mode Timing

The following subsections give the UART transmit and receive timings in IrDA mode.

4.7.17.3.3 UART IrDA Mode Transmitter

Figure 87 depicts the UART IrDA mode transmit timing, with 8 data bit/1 stop bit format. Table 92 lists the transmit timing characteristics.

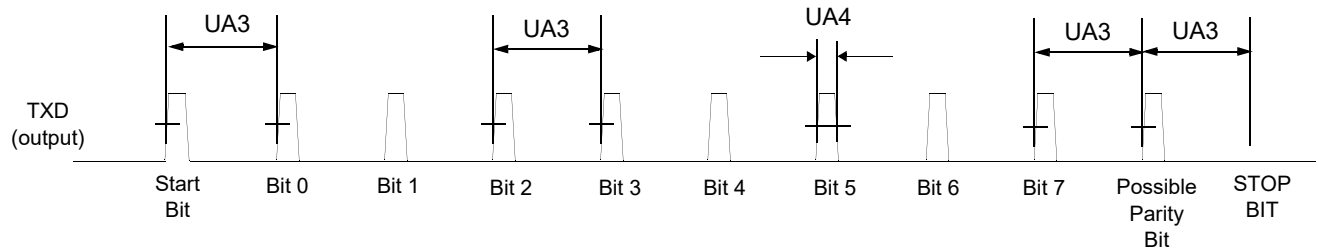

Figure 87. UART IrDA Mode Transmit Timing Diagram

Table 92. IrDA Mode Transmit Timing Parameters

ID	Parameter	Symbol	Min	Max	Units
UA3	Transmit Bit Time in IrDA mode	t_{TIRbit}	$1/F_{baud_rate} - T_{ref_clk}^2$ ¹	$1/F_{baud_rate} + T_{ref_clk}$	—
UA4	Transmit IR Pulse Duration	$t_{TIRpulse}$	$(3/16) \times (1/F_{baud_rate}) - T_{ref_clk}$	$(3/16) \times (1/F_{baud_rate}) + T_{ref_clk}$	—

¹ F_{baud_rate} : Baud rate frequency. The maximum baud rate the UART can support is $(ipg_perclk \text{ frequency})/16$.

² T_{ref_clk} : The period of UART reference clock ref_clk (ipg_perclk after RFDIV divider).

4.7.17.3.4 UART IrDA Mode Receiver

Figure 88 depicts the UART IrDA mode receive timing, with 8 data bit/1 stop bit format. Table 93 lists the receive timing characteristics.

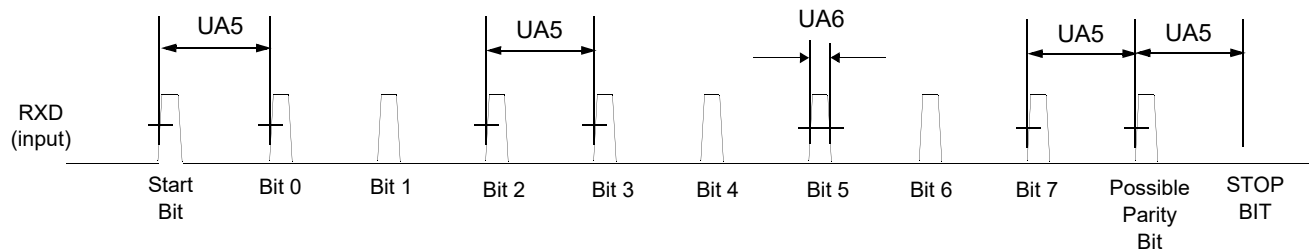

Figure 88. UART IrDA Mode Receive Timing Diagram

Table 93. IrDA Mode Receive Timing Parameters

ID	Parameter	Symbol	Min	Max	Units
UA5	Receive Bit Time ¹ in IrDA mode	t_{RIRbit}	$1/F_{baud_rate}^2 - 1/(16 \times F_{baud_rate})$	$1/F_{baud_rate} + 1/(16 \times F_{baud_rate})$	—
UA6	Receive IR Pulse Duration	$t_{RIRpulse}$	1.41 μ s	$(5/16) \times (1/F_{baud_rate})$	—

¹ The UART receiver can tolerate $1/(16 \times F_{baud_rate})$ tolerance in each bit. But accumulation tolerance in one frame must not exceed $3/(16 \times F_{baud_rate})$.

² F_{baud_rate} : Baud rate frequency. The maximum baud rate the UART can support is $(ipg_perclk \text{ frequency})/16$.

4.7.18 USB-OH-3 Parameters

This section describes the electrical parameters of the USB OTG port and USB HOST ports. For on-chip USB PHY parameters see [Section 4.7.19, “USB PHY Parameters.”](#)

4.7.18.1 Serial Interface

In order to support four serial different interfaces, the USB serial transceiver can be configured to operate in one of four modes:

- DAT_SE0 bidirectional, 3-wire mode
- DAT_SE0 unidirectional, 6-wire mode
- VP_VM bidirectional, 4-wire mode
- VP_VM unidirectional, 6-wire mode

4.7.18.1.1 DAT_SE0 Bidirectional Mode

Table 94. Signal Definitions — DAT_SE0 Bidirectional Mode

Name	Direction	Signal Description
USB_TXOE_B	Out	Transmit enable, active low
USB_DAT_VP	Out In	TX data when USB_TXOE_B is low Differential RX data when USB_TXOE_B is high
USB_SE0_VM	Out In	SE0 drive when USB_TXOE_B is low SE0 RX indicator when USB_TXOE_B is high

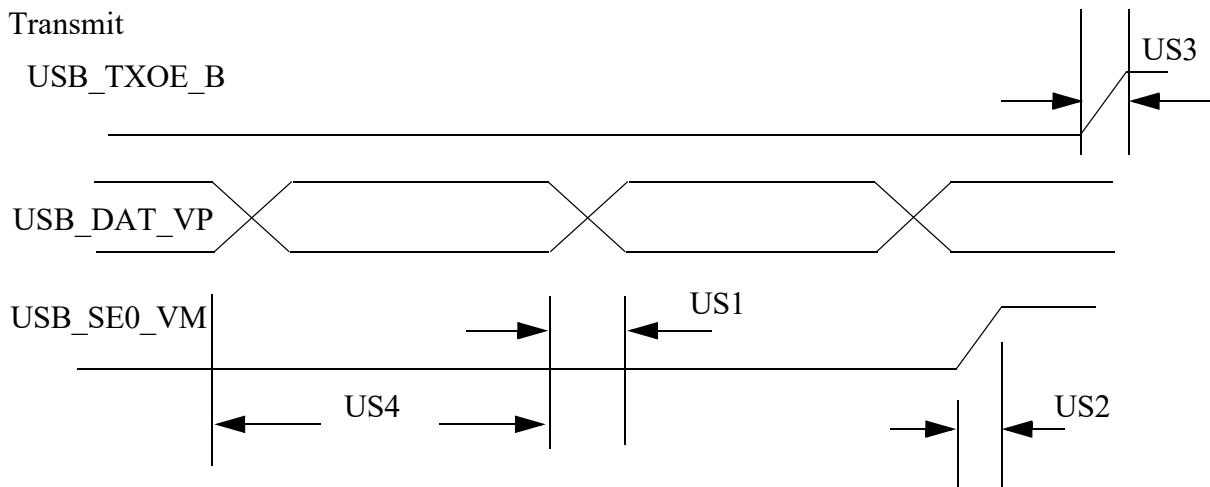

Figure 89. USB Transmit Waveform in DAT_SE0 Bidirectional Mode

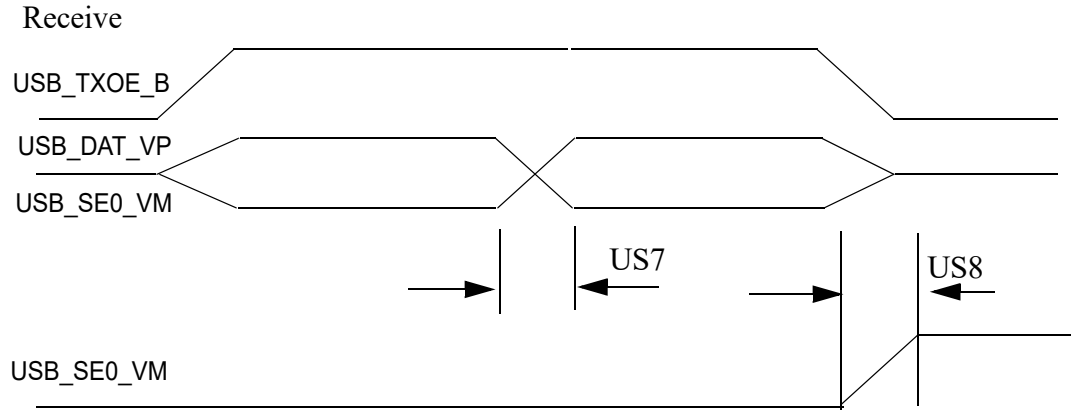

Figure 90. USB Receive Waveform in DAT_SE0 Bidirectional Mode

Table 95. Definitions of USB Waveform in DAT_SE0 Bi — Directional Mode

No.	Parameter	Signal Name	Direction	Min	Max	Unit	Conditions / Reference Signal
US1	TX Rise/Fall Time	USB_DAT_VP	Out	—	5.0	ns	50 pF
US2	TX Rise/Fall Time	USB_SE0_VM	Out	—	5.0	ns	50 pF
US3	TX Rise/Fall Time	USB_TXOE_B	Out	—	5.0	ns	50 pF
US4	TX Duty Cycle	USB_DAT_VP	Out	49.0	51.0	%	—
US7	RX Rise/Fall Time	USB_DAT_VP	In	—	3.0	ns	35 pF
US8	RX Rise/Fall Time	USB_SE0_VM	In	—	3.0	ns	35 pF

4.7.18.1.2 DAT_SE0 Unidirectional Mode

Table 96. Signal Definitions — DAT_SE0 Unidirectional Mode

Name	Direction	Signal Description
USB_TXOE_B	Out	Transmit enable, active low
USB_DAT_VP	Out	TX data when USB_TXOE_B is low
USB_SE0_VM	Out	SE0 drive when USB_TXOE_B is low
USB_VP1	In	Buffered data on DP when USB_TXOE_B is high
USB_VM1	In	Buffered data on DM when USB_TXOE_B is high

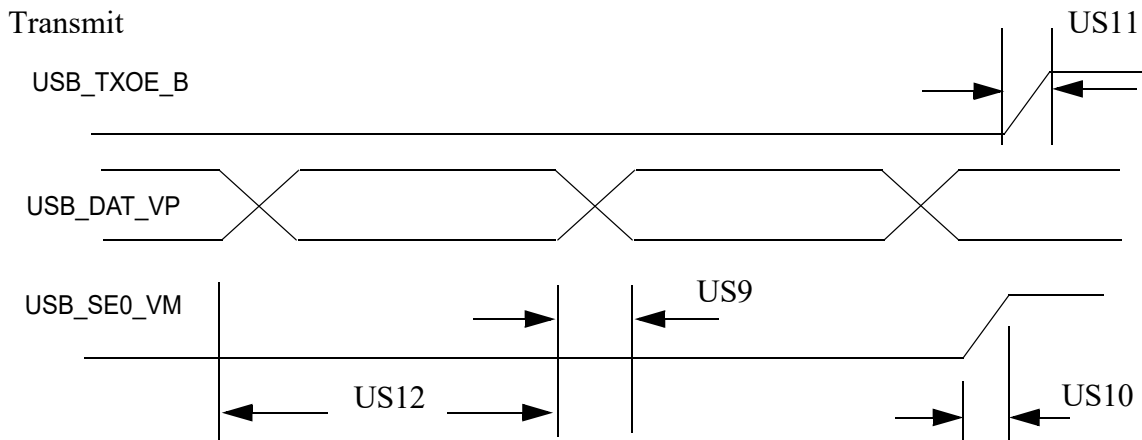

Figure 91. USB Transmit Waveform in DAT_SE0 Unidirectional Mode

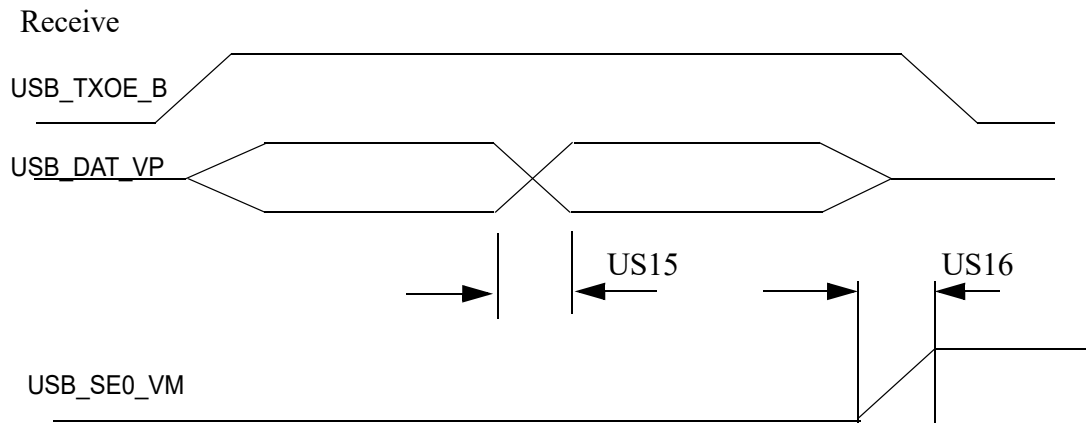

Figure 92. USB Receive Waveform in DAT_SE0 Unidirectional Mode

Table 97. USB Port Timing Specification in DAT_SE0 Unidirectional Mode

No.	Parameter	Signal Name	Signal Source	Min	Max	Unit	Condition / Reference Signal
US9	TX Rise/Fall Time	USB_DAT_VP	Out	—	5.0	ns	50 pF
US10	TX Rise/Fall Time	USB_SE0_VM	Out	—	5.0	ns	50 pF
US11	TX Rise/Fall Time	USB_TXOE_B	Out	—	5.0	ns	50 pF
US12	TX Duty Cycle	USB_DAT_VP	Out	49.0	51.0	%	—
US15	RX Rise/Fall Time	USB_VP1	In	—	3.0	ns	35 pF
US16	RX Rise/Fall Time	USB_VM1	In	—	3.0	ns	35 pF

4.7.18.1.3 VP_VM Bidirectional Mode

Table 98. Signal Definitions — VP_VM Bidirectional Mode

Name	Direction	Signal Description
USB_TXOE_B	Out	Transmit enable, active low
USB_DAT_VP	Out (Tx) In (Rx)	TX VP data when USB_TXOE_B is low RX VP data when USB_TXOE_B is high
USB_SE0_VM	Out (Tx) In (Rx)	TX VM data when USB_TXOE_B low RX VM data when USB_TXOE_B high

Transmit

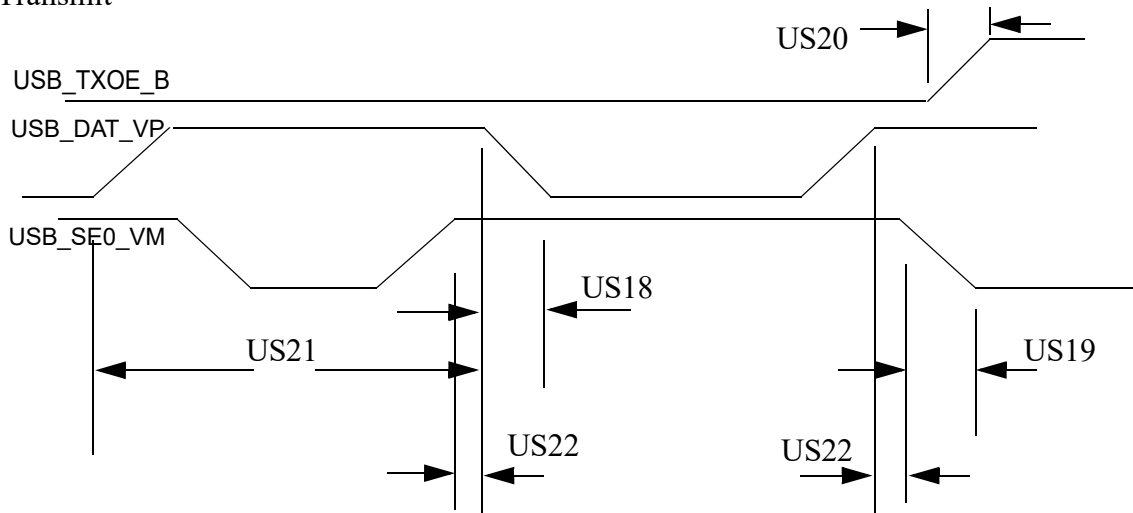

Figure 93. USB Transmit Waveform in VP_VM Bidirectional Mode

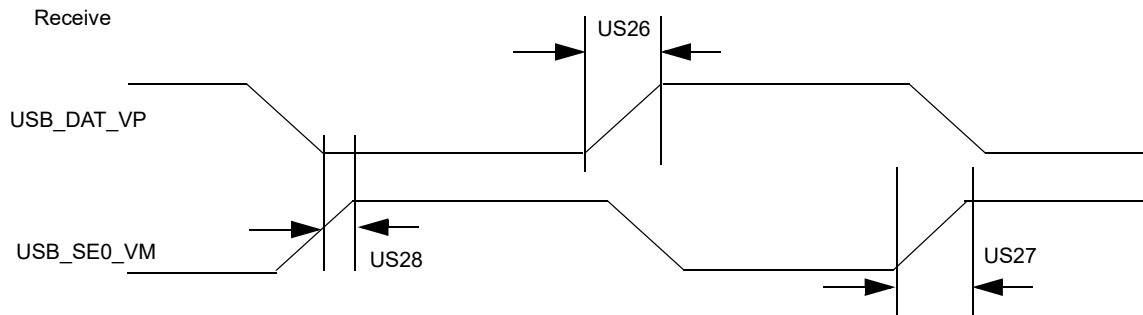

Figure 94. USB Receive Waveform in VP_VM Bidirectional Mode

Table 99. USB Port Timing Specification in VP_VM Bidirectional Mode

No.	Parameter	Signal Name	Direction	Min	Max	Unit	Condition / Reference Signal
US18	TX Rise/Fall Time	USB_DAT_VP	Out	—	5.0	ns	50 pF
US19	TX Rise/Fall Time	USB_SE0_VM	Out	—	5.0	ns	50 pF
US20	TX Rise/Fall Time	USB_TXOE_B	Out	—	5.0	ns	50 pF
US21	TX Duty Cycle	USB_DAT_VP	Out	49.0	51.0	%	—
US22	TX Overlap	USB_SE0_VM	Out	-3.0	+3.0	ns	USB_DAT_VP
US26	RX Rise/Fall Time	USB_DAT_VP	In	—	3.0	ns	35 pF
US27	RX Rise/Fall Time	USB_SE0_VM	In	—	3.0	ns	35 pF
US28	RX Skew	USB_DAT_VP	In	-4.0	+4.0	ns	USB_SE0_VM

4.7.18.1.4 VP_VM Unidirectional Mode

Table 100. Signal Definitions — VP_VM Unidirectional Mode

Name	Direction	Signal Description
USB_TXOE_B	Out	Transmit enable, active low
USB_DAT_VP	Out	TX VP data when USB_TXOE_B is low
USB_SE0_VM	Out	TX VM data when USB_TXOE_B is low
USB_VP1	In	RX VP data when USB_TXOE_B is high
USB_VM1	In	RX VM data when USB_TXOE_B is high

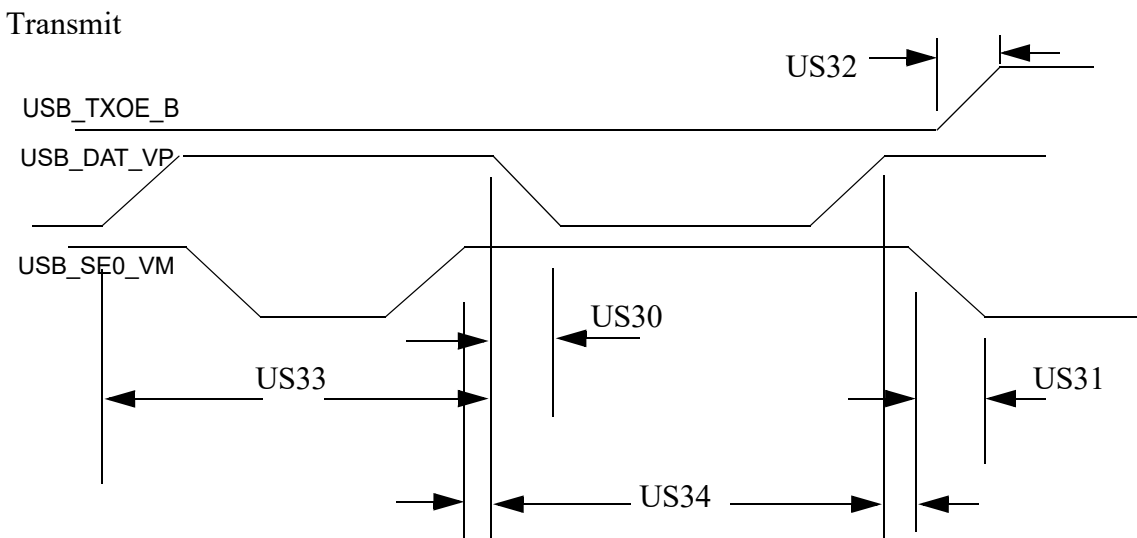

Figure 95. USB Transmit Waveform in VP_VM Unidirectional Mode

Receive

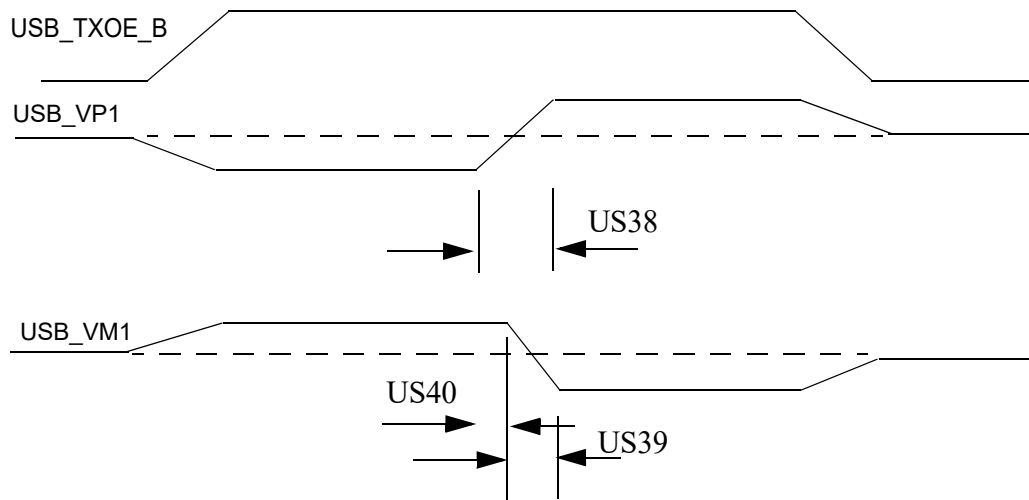

Figure 96. USB Receive Waveform in VP_VM Unidirectional Mode

Table 101. USB Timing Specification in VP_VM Unidirectional Mode

No.	Parameter	Signal	Direction	Min	Max	Unit	Conditions / Reference Signal
US30	TX Rise/Fall Time	USB_DAT_VP	Out	—	5.0	ns	50 pF
US31	TX Rise/Fall Time	USB_SE0_V M	Out	—	5.0	ns	50 pF
US32	TX Rise/Fall Time	USB_TXOE_ B	Out	—	5.0	ns	50 pF
US33	TX Duty Cycle	USB_DAT_VP	Out	49.0	51.0	%	—
US34	TX Overlap	USB_SE0_V M	Out	-3.0	3.0	ns	USB_DAT_VP
US38	RX Rise/Fall Time	USB_VP1	In	—	3.0	ns	35 pF
US39	RX Rise/Fall Time	USB_VM1	In	—	3.0	ns	35 pF
US40	RX Skew	USB_VP1	In	-4.0	+4.0	ns	USB_VM1

4.7.18.2 Parallel Interface (Normal ULPI) Timing

Electrical and timing specifications of Parallel Interface (Normal ULPI) for Host Port2 and Port3 are presented in the subsequent sections.

Table 102. Signal Definitions — Parallel Interface (Normal ULPI)

Name	Direction	Signal Description
USB_Clk	In	Interface clock. All interface signals are synchronous to Clock.
USB_Data[7:0]	I/O	Bi-directional data bus, driven low by the link during idle. Bus ownership is determined by Dir.
USB_Dir	In	Direction. Control the direction of the Data bus.
USB_Stp	Out	Stop. The link asserts this signal for 1 clock cycle to stop the data stream currently on the bus.
USB_Nxt	In	Next. The PHY asserts this signal to throttle the data.

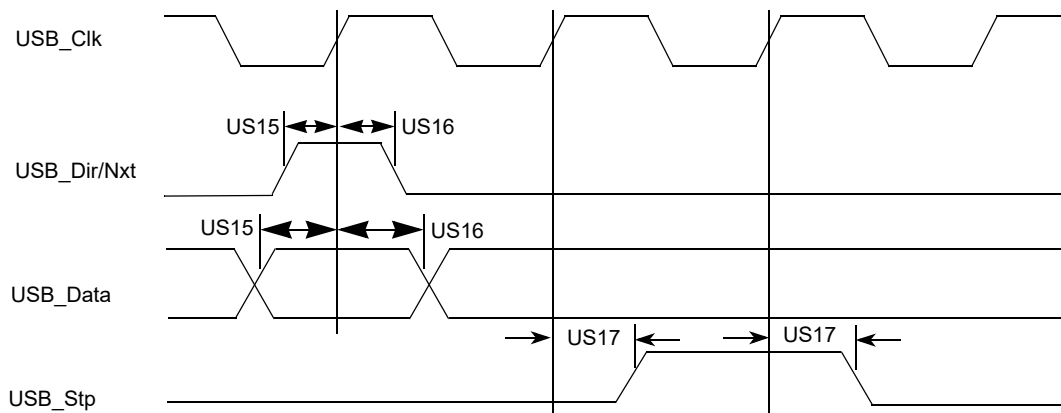

Figure 97. USB Transmit/Receive Waveform in Parallel Mode

Table 103. USB Timing Specification for Normal ULPI Mode

ID	Parameter	Min	Max	Unit	Conditions / Reference Signal
US15	Setup Time (Dir&Nxt in, Data in)	6.0	—	ns	10 pF
US16	Hold Time (Dir&Nxt in, Data in)	0.0	—	ns	10 pF
US17	Output Delay Time (Stp out, Data out)	—	9.0	ns	10 pF

4.7.19 USB PHY Parameters

This section describes the USB-OTG PHY and the USB Host port PHY parameters.

4.7.19.1 USB PHY AC Parameters

Table 104 lists the AC timing parameters for USB PHY.

Table 104. USB PHY AC Timing Parameters

Parameter	Conditions	Min	Typ	Max	Unit
trise	1.5 Mbps	75	—	300	ns
	12 Mbps	4		20	
	480 Mbps	0.5			
tfall	1.5 Mbps	75	—	300	ns
	12 Mbps	4		20	
	480 Mbps	0.5			
Jitter	1.5 Mbps	—	—	10	ns
	12 Mbps			1	
	480 Mbps			0.2	

4.7.19.2 USB PHY Additional Electrical Parameters

Table 105 lists the parameters for additional electrical characteristics for USB PHY.

Table 105. Additional Electrical Characteristics for USB PHY

Parameter	Conditions	Min	Typ	Max	Unit
Vcm DC (dc level measured at receiver connector)	HS Mode LS/FS Mode	-0.05 0.8	—	0.5 2.5	V
Crossover Voltage	LS Mode FS Mode	1.3 1.3	—	2 2	V
Power supply ripple noise (analog 3.3 V)	< 160 MHz	-50	0	50	mV
Power supply ripple noise (analog 2.5 V)	< 1.2 MHz	-10	0	10	mV
	> 1.2 MHz	-50	0	50	
Power supply ripple noise (Digital 1.2 V)	All conditions	-50	0	50	mV

4.7.19.3 USB PHY System Clocking (SYSCLK)

Table 106 lists the USB PHY system clocking parameters.

Table 106. USB PHY System Clocking Parameters

Parameter	Conditions	Min	Typ	Max	Unit
Clock deviation	Reference Clock frequency 24 MHz	-150	—	150	ppm
Rise/fall time	—	—	—	200	ps
Jitter (peak-peak)	< 1.2 MHz	0	—	50	ps
Jitter (peak-peak)	> 1.2 MHz	0	—	100	ps
Duty-cycle	Reference Clock frequency 24 MHz	40	—	60	%

4.7.19.4 USB PHY Voltage Thresholds

Table 107 lists the USB PHY voltage thresholds.

Table 107. VBUS Comparators Thresholds

Parameter	Conditions	Min	Typ	Max	Unit
A-Device Session Valid	—	0.8	1.4	2.0	V
B-Device Session Valid	—	0.8	1.4	4.0	V
B-Device Session End	—	0.2	0.45	0.8	V
VBUS Valid Comparator Threshold ¹	—	4.4	4.6	4.75	V

¹ For VBUS maximum rating, see Table 5 on page 16

4.7.19.5 USB PHY Termination

USB driver impedance in FS and HS modes is $45\ \Omega \pm 10\%$ (steady state). No external resistors required.

4.8 XTAL Electrical Specifications

Table 108 shows the XTALOSC electrical specifications.

Table 109 shows the XTALOSC_32K electrical specifications.

Table 108. XTALOSC Electrical Specifications

Parameter	Min	Typ	Max	Units
Frequency	22	24	27	MHz

Table 109. XTALOSC_32K Electrical Specifications

Parameter	Min	Typ	Max	Units
Frequency	—	32.768/32.0 ¹	—	kHz

¹ Recommended nominal frequency 32.768 kHz.

4.9 Integrated LDO Voltage Regulators Parameters

The PLL supplies VDD_DIG_PLL and VDD_ANA_PLL can be powered ON from internal LDO voltage regulator (default case). In this case VDD_REG is used as internal regulator's power source. The regulator's output can be used as a supply for other domains such as VDDA and VDDAL1.

Table 110 shows the VDD_DIG_PLL and VDD_ANA_PLL Integrated Voltage Regulators Parameters.

Table 110. LDO Voltage Regulators Electrical Specifications

Parameter	Symbol	Min	Typ	Max	Units
VDD_DIG_PLL functional Voltage Range ¹	V _{VID_DIG_PLL}	1.15	1.2	1.3	V
VDD_ANA_PLL functional Voltage Range ¹	V _{VDD_ANA_PLL}	1.7	1.8	1.95	V
VDD_DIG_PLL and VDD_ANA_PLL accuracy	—	—	—	±3	%
VDD_DIG_PLL power-supply rejection ratio ²	—	—	-18	—	dB
VDD_ANA_PLL power-supply rejection ratio ²	—	—	-15	—	dB
Output current ³	I _{VDD_DIG_PLL} ⁺ I _{VDD_ANA_PLL}	—	—	125	mA

¹ VDD_DIG_PLL and VDD_ANA_PLL voltages are programmable, but should not be set outside the target functional range for proper PLL operation.

² The gain or attenuation from the input supply variation to the output of the LDO (by design).

³ The limitation is for sum of the VDD_DIG_PLL and VDD_ANA_PLL current.

5 Boot Mode Configuration

This section provides information on boot mode configuration pins allocation and boot devices interfaces allocation.

5.1 Boot Mode Configuration Pins

Table 111 provides boot options, functionality, fuse values, and associated pins. Several input pins are also sampled at reset and can be used to override fuse values, depending on the value of BT_FUSE_SEL fuse. The boot option pins are in effect when BT_FUSE_SEL fuse is '0' (cleared, which is the case for an unblown fuse). For detailed boot mode options configured by the boot mode pins, see i.MX53 Fuse Map document and Boot chapter in i.MX53 reference manual.

Table 111. Fuses and Associated Pins Used for Boot

Pin	Direction at Reset	eFUSE Name	Details
BOOT_MODE[1]	Input	N/A	Boot Mode selection
BOOT_MODE[0]	Input		

Table 111. Fuses and Associated Pins Used for Boot (continued)

Pin	Direction at Reset	eFUSE Name	Details
EIM_A22	Input	BOOT_CFG1[7]/Test Mode Selection	Boot Options, Pin value overrides fuse settings for BT_FUSE_SEL = '0' . Signal Configuration as Fuse Override Input at Power Up. These are special I/O lines that control the boot up configuration during product development. In production, the boot configuration can be controlled by fuses.
EIM_A21	Input	BOOT_CFG1[6]/Test Mode Selection	
EIM_A20	Input	BOOT_CFG1[5]/Test Mode Selection	
EIM_A19	Input	BOOT_CFG1[4]	
EIM_A18	Input	BOOT_CFG1[3]	
EIM_A17	Input	BOOT_CFG1[2]	
EIM_A16	Input	BOOT_CFG1[1]	
EIM_LBA	Input	BOOT_CFG1[0]	
EIM_EB0	Input	BOOT_CFG2[7]	
EIM_EB1	Input	BOOT_CFG2[6]	
EIM_DA0	Input	BOOT_CFG2[5]	
EIM_DA1	Input	BOOT_CFG2[4]	
EIM_DA2	Input	BOOT_CFG2[3]	
EIM_DA3	Input	BOOT_CFG2[2]	
EIM_DA4	Input	BOOT_CFG3[7]	
EIM_DA5	Input	BOOT_CFG3[6]	
EIM_DA6	Input	BOOT_CFG3[5]	
EIM_DA7	Input	BOOT_CFG3[4]	
EIM_DA8	Input	BOOT_CFG3[3]	
EIM_DA9	Input	BOOT_CFG3[2]	
EIM_DA10	Input	BOOT_CFG3[1]	

5.2 Boot Devices Interfaces Allocation

Table 112 lists the interfaces that can be used by the boot process in accordance with the specific boot mode configuration. The table also describes the interface’s specific modes and IOMUXC allocation, which are configured during boot when appropriate.

Table 112. Interfaces Allocation During Boot

Interface	IP Instance	Allocated Pads During Boot	Comment
SPI	CSPI	EIM_A25, EIM_D21, EIM_D22, EIM_D28	Only SS1 is supported
SPI	ECSPI-1	EIM_D[19:16]	Only SS1 is supported
SPI	ECSPI-2	CSI_DAT[10:8], EIM_LBA	Only SS1 is supported

Table 112. Interfaces Allocation During Boot (continued)

Interface	IP Instance	Allocated Pads During Boot	Comment
EIM	EIM	EIM	<ul style="list-style-type: none"> Lower 16-bit data bus A/D multiplexed or upper 16 bit data bus non multiplexed Only CS0 is supported.
NAND Flash	EXTMC	NAND	<ul style="list-style-type: none"> 8/16-bit NAND data can be muxed either over EIM data or PATA data Only CS0 is supported
SD/MMC	eSDHCv2-1	PATA_DATA[11:8], SD1_DATA[3:0], SD1_CMD, SD1_CLK	1, 4, or 8 bit
SD/MMC	eSDHCv2-2	PATA_DATA[15:12], SD2_CLK, SD2_CMD, SD2_DATA[3:0]	1, 4, or 8 bit
SD/MMC	eSDHCv3-3	PATA_RESET_B, PATA_IORDY, PATA_DA_0, PATA_DATA[3:0], PATA_DATA[11:8]	1, 4, or 8 bit
SD/MMC	eSDHCv2-4	PATA_DA1, PATA_DA_2, PATA_DATA[7:4], PATA_DATA[15:12]	1, 4, or 8 bit
I2C	I2C-1	EIM_D21, EIM_D28	—
I2C	I2C-2	EIM_D16, EIM_EB2	—
I2C	I2C-3	EIM_D[18:17]	—
PATA	PATA	PATA_DIOW, PATA_DMACK, PATA_DMARQ, PATA_BUFFER_EN, PATA_INTRQ, PATA_DIOR, PATA_RESET_B, PATA_IORDY, PATA_DA_[2:0], PATA_CS_[1:0], PATA_DATA[15:0]	—
SATA	SATA_PHY	SATA_TXM, SATA_TXP, SATA_RXP, SATA_RXM, SATA_REXT, SATA_REFCLKM, SATA_REFCLKP	—
UART	UARTv2-1	CSI0_DAT[11:10]	RXD/TXD only
UART	UARTv2-2	PATA_DMARQ, PATA_BUFFER_EN	RXD/TXD only
UART	UARTv2-3	EIM_D24, EIM_D25	RXD/TXD only
UART	UARTv2-4	CSI0_DAT[13:12]	RXD/TXD only
UART	UARTv2-5	CSI0_DAT[15:14]	RXD/TXD only
USB	USB-OTG PHY	USB_H1_GPANAIO USB_H1_RREFEXT USB_H1_DP USB_H1_DN USB_H1_VBUS	—

5.3 Power Setup During Boot

By default, VDD_DIG_PLL is driven from internal on-die 1.2 V linear regulator (LDO). In order to achieve the standard operating mode (see VDD_DIG_PLL on [Table 7](#)), LDO output to VDD_DIG_PLL should be configured by software by boot code after power-up to 1.3 V output. This is done by programming the PLL1P2_VREG bits.

6 Package Information and Contact Assignments

This section includes the contact assignment information and mechanical package drawing.

6.1 19x19 mm Package Information

This section contains the outline drawing, signal assignment map, ground/power reference ID (by ball grid location) for the 19 × 19 mm, 0.8 mm pitch package.

6.1.1 Case TEPBGA-529, 19 x 19 mm, 0.8 mm Pitch, 23 x 23 Ball Matrix

Figure 98 shows the top view of the 19×19 mm package, Figure 99 shows the bottom view and the ball location (529 solder balls) of the 19×19 mm package, and Figure 100 shows the side view of the 19×19 mm package.

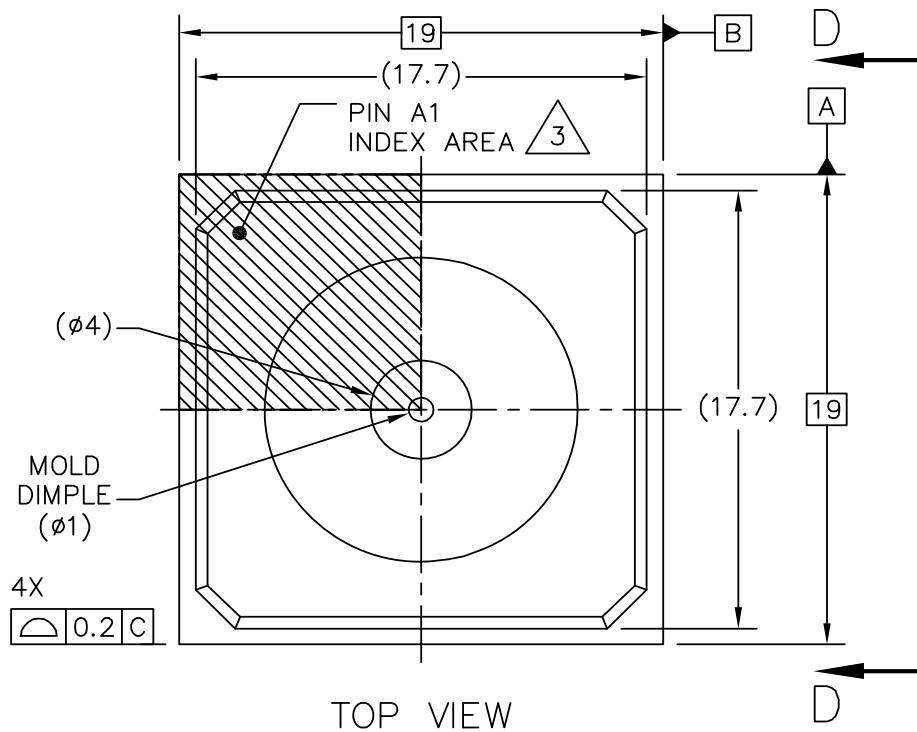
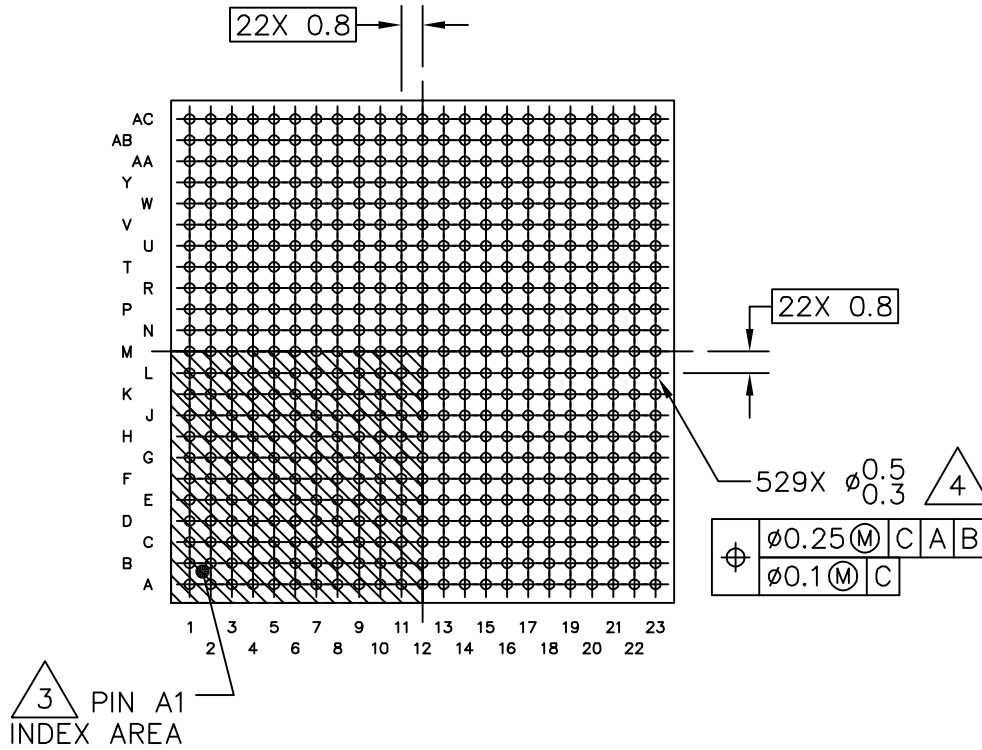

Figure 98. 19 x 19 mm Package Top View



BOTTOM VIEW

Figure 99. 19 x 19 mm Package, 529 Solder Balls, Bottom View

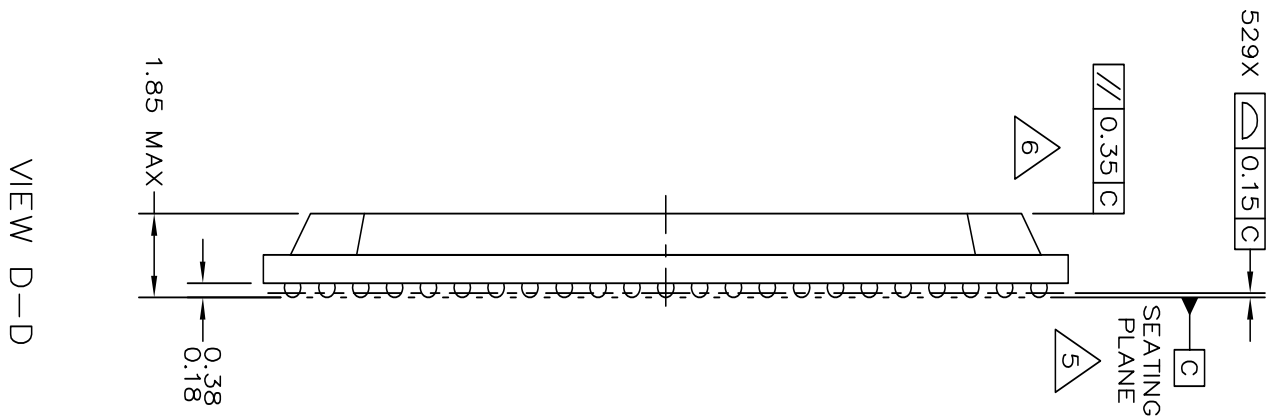

Figure 100. 19 x 19 mm Package Side View

The following notes apply to [Figure 98](#), [Figure 99](#), and [Figure 100](#).

1. All dimensions are in millimeters.
2. Dimensions and tolerancing per ASME Y14.5M–1994.

6.1.2 19 x 19 mm Ground, Power, Sense, and Reference Contact Assignments

[Table 113](#) shows the device connection list for ground, power, sense, and reference contact signals alpha-sorted by name.

Table 113. 19 x 19 mm Ground, Power, Sense, and Reference Contact Assignments

Contact Name	Package Contact Assignment(s)
DDR_VREF	L17
GND	A1, A11, A13, A18, A2, A22, A23, AA11, AA15, AA20, AA21, AB1, AB18, AB2, AB22, AB23, AC1, AC18, AC2, AC22, AC23, B1, B11, B13, B18, B23, C12, C20, C21, D19, E19, F19, F20, F21, F22, G19, G7, H10, H12, H8, J11, J13, J15, J17, J20, J9, K10, K12, K14, K16, K21, K8, L11, L13, L15, L7, L9, M10, M12, M14, M16, M8, N11, N13, N15, N9, P10, P12, P14, P16, P21, P7, P8, R11, R13, R15, R17, R20, R9, T10, T14, T16, T8, U15, U19, V15, V18, V19, V20, V21, V22, W19, Y14, Y15, Y19
NVCC_CKIH	G17
NVCC_CSI	R7
NVCC_EIM_MAIN	U10, U9
NVCC_EIM_SEC	U7
NVCC_EMI_DRAM	H18, K17, N17, P17, T18
NVCC_FEC	F11
NVCC_GPIO	F8
NVCC_JTAG	G9
NVCC_KEYPAD	F7
NVCC_LCD	J6, J7
NVCC_LVDS	U13
NVCC_LVDS_BG	U14
NVCC_NANDF	T12
NVCC_PATA	N7
NVCC_RESET	H16
NVCC_SD1	H15
NVCC_SD2	H14
NVCC_SRTC_POW	V11
NVCC_XTAL	V12
SVCC	B22

Table 113. 19 x 19 mm Ground, Power, Sense, and Reference Contact Assignments (continued)

Contact Name	Package Contact Assignment(s)
SVDDGP	B2
TVDAC_AHVDDRGB	U17, V16
TVDAC_DHVDD	U16
USB_H1_VDDA25	F13
USB_H1_VDDA33	G13
USB_OTG_VDDA25	F14
USB_OTG_VDDA33	G14
VCC	H13, J14, J16, K13, K15, L14, L16, M11, M13, M15, M9, N10, N12, N14, N16, N8, P11, P13, P15, P9, R10, R12, R14, R16, R8, T11, T13, T15, T17, T7, T9, U18, U8
VDDA	G12, M17, M7, U12
VDDAL1	F9
VDD_ANA_PLL	G16
VDD_DIG_PLL	H17
VDD_FUSE	G15
VDDGP	G10, G11, G8, H11, H7, H9, J10, J12, J8, K11, K7, K9, L10, L12, L8
VDD_REG	G18
VP	A15, B15
VPH	A9, B9

6.1.3 19 x 19 mm Signal Assignments, Power Rails, and I/O

Table 114 displays an alpha-sorted list of the signal assignments including power rails. The table also includes out of reset pad state.

Table 114. 19 x 19 mm Signal Assignments, Power Rails, and I/O

Contact Name	Contact Assignment	Power Rail	I/O Buffer Type	Out of Reset Condition ¹				
				Alt. Mode	Block Instance	Block I/O	Direction	Config. Value
BOOT_MODE0	C18	NVCC_RESET	LVIO	ALT0	SRC	src_BOOT_MO DE[0]	Input	100 KΩ PD
BOOT_MODE1	B20	NVCC_RESET	LVIO	ALT0	SRC	src_BOOT_MO DE[1]	Input	100 KΩ PD
CKIH1	B21	NVCC_CKIH	ANALOG	ALT0	CAMP-1	camp1_CKIH	Input	Analog
CKIH2	D18	NVCC_CKIH	ANALOG	ALT0	CAMP-2	camp2_CKIH	Input	Analog
CKIL	AB10	NVCC_SRTC_POW	ANALOG	—	SRCT	CKIL	—	—

Table 114. 19 x 19 mm Signal Assignments, Power Rails, and I/O (continued)

Contact Name	Contact Assignment	Power Rail	I/O Buffer Type	Out of Reset Condition ¹				
				Alt. Mode	Block Instance	Block I/O	Direction	Config. Value
CSI0_DAT10	R5	NVCC_CSI	UHVIO	ALT1	GPIO-5	gpio5_GPIO[28]	Input	100 K Ω PU
CSI0_DAT11	T2	NVCC_CSI	UHVIO	ALT1	GPIO-5	gpio5_GPIO[29]	Input	100 K Ω PU
CSI0_DAT12	T3	NVCC_CSI	UHVIO	ALT1	GPIO-5	gpio5_GPIO[30]	Input	360 K Ω PD
CSI0_DAT13	T6	NVCC_CSI	UHVIO	ALT1	GPIO-5	gpio5_GPIO[31]	Input	360 K Ω PD
CSI0_DAT14	U1	NVCC_CSI	UHVIO	ALT1	GPIO-6	gpio6_GPIO[0]	Input	360 K Ω PD
CSI0_DAT15	U2	NVCC_CSI	UHVIO	ALT1	GPIO-6	gpio6_GPIO[1]	Input	360 K Ω PD
CSI0_DAT16	T4	NVCC_CSI	UHVIO	ALT1	GPIO-6	gpio6_GPIO[2]	Input	360 K Ω PD
CSI0_DAT17	T5	NVCC_CSI	UHVIO	ALT1	GPIO-6	gpio6_GPIO[3]	Input	360 K Ω PD
CSI0_DAT18	U3	NVCC_CSI	UHVIO	ALT1	GPIO-6	gpio6_GPIO[4]	Input	360 K Ω PD
CSI0_DAT19	U4	NVCC_CSI	UHVIO	ALT1	GPIO-6	gpio6_GPIO[5]	Input	360 K Ω PD
CSI0_DAT4	R1	NVCC_CSI	UHVIO	ALT1	GPIO-5	gpio5_GPIO[22]	Input	100 K Ω PU
CSI0_DAT5	R2	NVCC_CSI	UHVIO	ALT1	GPIO-5	gpio5_GPIO[23]	Input	360 K Ω PD
CSI0_DAT6	R6	NVCC_CSI	UHVIO	ALT1	GPIO-5	gpio5_GPIO[24]	Input	100 K Ω PU
CSI0_DAT7	R3	NVCC_CSI	UHVIO	ALT1	GPIO-5	gpio5_GPIO[25]	Input	100 K Ω PU
CSI0_DAT8	T1	NVCC_CSI	UHVIO	ALT1	GPIO-5	gpio5_GPIO[26]	Input	100 K Ω PU
CSI0_DAT9	R4	NVCC_CSI	UHVIO	ALT1	GPIO-5	gpio5_GPIO[27]	Input	360 K Ω PD
CSI0_DATA_EN	P3	NVCC_CSI	UHVIO	ALT1	GPIO-5	gpio5_GPIO[20]	Input	100 K Ω PU
CSI0_MCLK	P2	NVCC_CSI	UHVIO	ALT1	GPIO-5	gpio5_GPIO[19]	Input	100 K Ω PU
CSI0_PIXCLK	P1	NVCC_CSI	UHVIO	ALT1	GPIO-5	gpio5_GPIO[18]	Input	100 K Ω PU

Table 114. 19 x 19 mm Signal Assignments, Power Rails, and I/O (continued)

Contact Name	Contact Assignment	Power Rail	I/O Buffer Type	Out of Reset Condition ¹				
				Alt. Mode	Block Instance	Block I/O	Direction	Config. Value
CSI0_VSYNC	P4	NVCC_CSI	UHVIO	ALT1	GPIO-5	gpio5_GPIO[21]	Input	100 KΩ PU
DIO_DISP_CLK	H4	NVCC_LCD	GPIO	ALT1	GPIO-4	gpio4_GPIO[16]	Input	100 KΩ PU
DIO_PIN15	E4	NVCC_LCD	GPIO	ALT1	GPIO-4	gpio4_GPIO[17]	Input	100 KΩ PU
DIO_PIN2	D3	NVCC_LCD	GPIO	ALT1	GPIO-4	gpio4_GPIO[18]	Input	100 KΩ PU
DIO_PIN3	C2	NVCC_LCD	GPIO	ALT1	GPIO-4	gpio4_GPIO[19]	Input	100 KΩ PU
DIO_PIN4	D2	NVCC_LCD	GPIO	ALT1	GPIO-4	gpio4_GPIO[20]	Input	100 KΩ PU
DISP0_DAT0	J5	NVCC_LCD	GPIO	ALT1	GPIO-4	gpio4_GPIO[21]	Input	100 KΩ PD
DISP0_DAT1	J4	NVCC_LCD	GPIO	ALT1	GPIO-4	gpio4_GPIO[22]	Input	100 KΩ PD
DISP0_DAT10	G3	NVCC_LCD	GPIO	ALT1	GPIO-4	gpio4_GPIO[31]	Input	100 KΩ PU
DISP0_DAT11	H5	NVCC_LCD	GPIO	ALT1	GPIO-5	gpio5_GPIO[5]	Input	100 KΩ PD
DISP0_DAT12	H1	NVCC_LCD	GPIO	ALT1	GPIO-5	gpio5_GPIO[6]	Input	100 KΩ PU
DISP0_DAT13	E1	NVCC_LCD	GPIO	ALT1	GPIO-5	gpio5_GPIO[7]	Input	100 KΩ PU
DISP0_DAT14	F2	NVCC_LCD	GPIO	ALT1	GPIO-5	gpio5_GPIO[8]	Input	100 KΩ PU
DISP0_DAT15	F3	NVCC_LCD	GPIO	ALT1	GPIO-5	gpio5_GPIO[9]	Input	100 KΩ PU
DISP0_DAT16	D1	NVCC_LCD	GPIO	ALT1	GPIO-5	gpio5_GPIO[10]	Input	100 KΩ PU
DISP0_DAT17	F5	NVCC_LCD	GPIO	ALT1	GPIO-5	gpio5_GPIO[11]	Input	100 KΩ PU
DISP0_DAT18	G4	NVCC_LCD	GPIO	ALT1	GPIO-5	gpio5_GPIO[12]	Input	100 KΩ PU
DISP0_DAT19	G5	NVCC_LCD	GPIO	ALT1	GPIO-5	gpio5_GPIO[13]	Input	100 KΩ PU
DISP0_DAT2	H2	NVCC_LCD	GPIO	ALT1	GPIO-4	gpio4_GPIO[23]	Input	100 KΩ PD

Table 114. 19 x 19 mm Signal Assignments, Power Rails, and I/O (continued)

Contact Name	Contact Assignment	Power Rail	I/O Buffer Type	Out of Reset Condition ¹				
				Alt. Mode	Block Instance	Block I/O	Direction	Config. Value
DISP0_DAT20	F4	NVCC_LCD	GPIO	ALT1	GPIO-5	gpio5_GPIO[14]	Input	100 K Ω PU
DISP0_DAT21	C1	NVCC_LCD	GPIO	ALT1	GPIO-5	gpio5_GPIO[15]	Input	100 K Ω PU
DISP0_DAT22	E3	NVCC_LCD	GPIO	ALT1	GPIO-5	gpio5_GPIO[16]	Input	100 K Ω PU
DISP0_DAT23	C3	NVCC_LCD	GPIO	ALT1	GPIO-5	gpio5_GPIO[17]	Input	100 K Ω PU
DISP0_DAT3	F1	NVCC_LCD	GPIO	ALT1	GPIO-4	gpio4_GPIO[24]	Input	100 K Ω PD
DISP0_DAT4	G2	NVCC_LCD	GPIO	ALT1	GPIO-4	gpio4_GPIO[25]	Input	100 K Ω PD
DISP0_DAT5	H3	NVCC_LCD	GPIO	ALT1	GPIO-4	gpio4_GPIO[26]	Input	100 K Ω PD
DISP0_DAT6	G1	NVCC_LCD	GPIO	ALT1	GPIO-4	gpio4_GPIO[27]	Input	100 K Ω PD
DISP0_DAT7	H6	NVCC_LCD	GPIO	ALT1	GPIO-4	gpio4_GPIO[28]	Input	100 K Ω PD
DISP0_DAT8	G6	NVCC_LCD	GPIO	ALT1	GPIO-4	gpio4_GPIO[29]	Input	100 K Ω PU
DISP0_DAT9	E2	NVCC_LCD	GPIO	ALT1	GPIO-4	gpio4_GPIO[30]	Input	100 K Ω PU
DRAM_A0	M19	NVCC_EMI_DRAM	DDR3	ALT0	EXTMC	emi_DRAM_A[0]	Output	Low
DRAM_A1	L21	NVCC_EMI_DRAM	DDR3	ALT0	EXTMC	emi_DRAM_A[1]	Output	Low
DRAM_A10	K19	NVCC_EMI_DRAM	DDR3	ALT0	EXTMC	emi_DRAM_A[10]	Output	Low
DRAM_A11	L22	NVCC_EMI_DRAM	DDR3	ALT0	EXTMC	emi_DRAM_A[11]	Output	Low
DRAM_A12	L20	NVCC_EMI_DRAM	DDR3	ALT0	EXTMC	emi_DRAM_A[12]	Output	Low
DRAM_A13	L23	NVCC_EMI_DRAM	DDR3	ALT0	EXTMC	emi_DRAM_A[13]	Output	Low
DRAM_A14	N18	NVCC_EMI_DRAM	DDR3	ALT0	EXTMC	emi_DRAM_A[14]	Output	Low
DRAM_A15	M18	NVCC_EMI_DRAM	DDR3	ALT0	EXTMC	emi_DRAM_A[15]	Output	Low
DRAM_A2	M20	NVCC_EMI_DRAM	DDR3	ALT0	EXTMC	emi_DRAM_A[2]	Output	Low

Table 114. 19 x 19 mm Signal Assignments, Power Rails, and I/O (continued)

Contact Name	Contact Assignment	Power Rail	I/O Buffer Type	Out of Reset Condition ¹				
				Alt. Mode	Block Instance	Block I/O	Direction	Config. Value
DRAM_A3	N20	NVCC_EMI_DRAM	DDR3	ALT0	EXTMC	emi_DRAM_A[3]	Output	Low
DRAM_A4	K20	NVCC_EMI_DRAM	DDR3	ALT0	EXTMC	emi_DRAM_A[4]	Output	Low
DRAM_A5	N21	NVCC_EMI_DRAM	DDR3	ALT0	EXTMC	emi_DRAM_A[5]	Output	Low
DRAM_A6	M22	NVCC_EMI_DRAM	DDR3	ALT0	EXTMC	emi_DRAM_A[6]	Output	Low
DRAM_A7	N22	NVCC_EMI_DRAM	DDR3	ALT0	EXTMC	emi_DRAM_A[7]	Output	Low
DRAM_A8	N23	NVCC_EMI_DRAM	DDR3	ALT0	EXTMC	emi_DRAM_A[8]	Output	Low
DRAM_A9	M21	NVCC_EMI_DRAM	DDR3	ALT0	EXTMC	emi_DRAM_A[9]	Output	Low
DRAM_CALIBRATION	M23	NVCC_EMI_DRAM	special	—	—	(used in DRAM driver calibration. See Section 3.1 , “Special Signal Considerations”)	Input	—
DRAM_CAS	L18	NVCC_EMI_DRAM	DDR3	ALT0	EXTMC	emi_DRAM_CAS	Output	High
DRAM_CS0	K18	NVCC_EMI_DRAM	DDR3	ALT0	EXTMC	emi_DRAM_CS[0]	Output	High
DRAM_CS1	P19	NVCC_EMI_DRAM	DDR3	ALT0	EXTMC	emi_DRAM_CS[1]	Output	High
DRAM_D0	H20	NVCC_EMI_DRAM	DDR3	ALT0	EXTMC	emi_DRAM_D[0]	Output	High
DRAM_D1	G21	NVCC_EMI_DRAM	DDR3	ALT0	EXTMC	emi_DRAM_D[1]	Output	High
DRAM_D10	E22	NVCC_EMI_DRAM	DDR3	ALT0	EXTMC	emi_DRAM_D[10]	Output	High
DRAM_D11	D20	NVCC_EMI_DRAM	DDR3	ALT0	EXTMC	emi_DRAM_D[11]	Output	High
DRAM_D12	E23	NVCC_EMI_DRAM	DDR3	ALT0	EXTMC	emi_DRAM_D[12]	Output	High
DRAM_D13	C23	NVCC_EMI_DRAM	DDR3	ALT0	EXTMC	emi_DRAM_D[13]	Output	High
DRAM_D14	F23	NVCC_EMI_DRAM	DDR3	ALT0	EXTMC	emi_DRAM_D[14]	Output	High
DRAM_D15	C22	NVCC_EMI_DRAM	DDR3	ALT0	EXTMC	emi_DRAM_D[15]	Output	High
DRAM_D16	U20	NVCC_EMI_DRAM	DDR3	ALT0	EXTMC	emi_DRAM_D[16]	Output	High

Table 114. 19 x 19 mm Signal Assignments, Power Rails, and I/O (continued)

Contact Name	Contact Assignment	Power Rail	I/O Buffer Type	Out of Reset Condition ¹				
				Alt. Mode	Block Instance	Block I/O	Direction	Config. Value
DRAM_D17	T21	NVCC_EMI_DRAM	DDR3	ALT0	EXTMC	emi_DRAM_D[17]	Output	High
DRAM_D18	U21	NVCC_EMI_DRAM	DDR3	ALT0	EXTMC	emi_DRAM_D[18]	Output	High
DRAM_D19	R21	NVCC_EMI_DRAM	DDR3	ALT0	EXTMC	emi_DRAM_D[19]	Output	High
DRAM_D2	J21	NVCC_EMI_DRAM	DDR3	ALT0	EXTMC	emi_DRAM_D[21]	Output	High
DRAM_D20	U23	NVCC_EMI_DRAM	DDR3	ALT0	EXTMC	emi_DRAM_D[20]	Output	High
DRAM_D21	R22	NVCC_EMI_DRAM	DDR3	ALT0	EXTMC	emi_DRAM_D[21]	Output	High
DRAM_D22	U22	NVCC_EMI_DRAM	DDR3	ALT0	EXTMC	emi_DRAM_D[22]	Output	High
DRAM_D23	R23	NVCC_EMI_DRAM	DDR3	ALT0	EXTMC	emi_DRAM_D[23]	Output	High
DRAM_D24	Y20	NVCC_EMI_DRAM	DDR3	ALT0	EXTMC	emi_DRAM_D[24]	Output	High
DRAM_D25	W21	NVCC_EMI_DRAM	DDR3	ALT0	EXTMC	emi_DRAM_D[25]	Output	High
DRAM_D26	Y21	NVCC_EMI_DRAM	DDR3	ALT0	EXTMC	emi_DRAM_D[26]	Output	High
DRAM_D27	W22	NVCC_EMI_DRAM	DDR3	ALT0	EXTMC	emi_DRAM_D[27]	Output	High
DRAM_D28	AA23	NVCC_EMI_DRAM	DDR3	ALT0	EXTMC	emi_DRAM_D[28]	Output	High
DRAM_D29	V23	NVCC_EMI_DRAM	DDR3	ALT0	EXTMC	emi_DRAM_D[29]	Output	High
DRAM_D3	G20	NVCC_EMI_DRAM	DDR3	ALT0	EXTMC	emi_DRAM_D[31]	Output	High
DRAM_D30	AA22	NVCC_EMI_DRAM	DDR3	ALT0	EXTMC	emi_DRAM_D[30]	Output	High
DRAM_D31	W23	NVCC_EMI_DRAM	DDR3	ALT0	EXTMC	emi_DRAM_D[31]	Output	High
DRAM_D4	J23	NVCC_EMI_DRAM	DDR3	ALT0	EXTMC	emi_DRAM_D[41]	Output	High
DRAM_D5	G23	NVCC_EMI_DRAM	DDR3	ALT0	EXTMC	emi_DRAM_D[51]	Output	High

Table 114. 19 x 19 mm Signal Assignments, Power Rails, and I/O (continued)

Contact Name	Contact Assignment	Power Rail	I/O Buffer Type	Out of Reset Condition ¹				
				Alt. Mode	Block Instance	Block I/O	Direction	Config. Value
DRAM_D6	J22	NVCC_EMI_DRAM	DDR3	ALT0	EXTMC	emi_DRAM_D[6]	Output	High
DRAM_D7	G22	NVCC_EMI_DRAM	DDR3	ALT0	EXTMC	emi_DRAM_D[7]	Output	High
DRAM_D8	E21	NVCC_EMI_DRAM	DDR3	ALT0	EXTMC	emi_DRAM_D[8]	Output	High
DRAM_D9	D21	NVCC_EMI_DRAM	DDR3	ALT0	EXTMC	emi_DRAM_D[9]	Output	High
DRAM_DQM0	H21	NVCC_EMI_DRAM	DDR3	ALT0	EXTMC	emi_DRAM_DQM[0]	Output	Low
DRAM_DQM1	E20	NVCC_EMI_DRAM	DDR3	ALT0	EXTMC	emi_DRAM_DQM[1]	Output	Low
DRAM_DQM2	T20	NVCC_EMI_DRAM	DDR3	ALT0	EXTMC	emi_DRAM_DQM[2]	Output	Low
DRAM_DQM3	W20	NVCC_EMI_DRAM	DDR3	ALT0	EXTMC	emi_DRAM_DQM[3]	Output	Low
DRAM_RAS	J19	NVCC_EMI_DRAM	DDR3	ALT0	EXTMC	emi_DRAM_RAS	Output	High
DRAM_RESET	P18	NVCC_EMI_DRAM	DDR3	ALT0	EXTMC	emi_DRAM_RESET	Output	Low
DRAM_SDBA0	R19	NVCC_EMI_DRAM	DDR3	ALT0	EXTMC	emi_DRAM_SDBA[0]	Output	Low
DRAM_SDBA1	P20	NVCC_EMI_DRAM	DDR3	ALT0	EXTMC	emi_DRAM_SDBA[1]	Output	Low
DRAM_SDBA2	N19	NVCC_EMI_DRAM	DDR3	ALT0	EXTMC	emi_DRAM_SDBA[2]	Output	Low
DRAM_SDCKE0	H19	NVCC_EMI_DRAM	DDR3	ALT0	EXTMC	emi_DRAM_SDCKE[0]	Output	Low
DRAM_SDCKE1	T19	NVCC_EMI_DRAM	DDR3	ALT0	EXTMC	emi_DRAM_SDCKE[1]	Output	Low
DRAM_SDCLK_0	K23	NVCC_EMI_DRAM	DDR3CLK	ALT0	EXTMC	emi_DRAM_SDCLK0	Output	Floating
DRAM_SDCLK_0_B	K22	NVCC_EMI_DRAM	DDR3CLK	ALT0	EXTMC	emi_DRAM_SDCLK0_B	Output	Floating
DRAM_SDCLK_1	P22	NVCC_EMI_DRAM	DDR3CLK	ALT0	EXTMC	emi_DRAM_SDCLK1	Output	Floating
DRAM_SDCLK_1_B	P23	NVCC_EMI_DRAM	DDR3CLK	ALT0	EXTMC	emi_DRAM_SDCLK1_B	Output	Floating

Table 114. 19 x 19 mm Signal Assignments, Power Rails, and I/O (continued)

Contact Name	Contact Assignment	Power Rail	I/O Buffer Type	Out of Reset Condition ¹				
				Alt. Mode	Block Instance	Block I/O	Direction	Config. Value
DRAM_SDODT0	J18	NVCC_EMI_DRAM	DDR3	ALT0	EXTMC	emi_DRAM_OD T[0]	Output	Low
DRAM_SDODT1	R18	NVCC_EMI_DRAM	DDR3	ALT0	EXTMC	emi_DRAM_OD T[1]	Output	Low
DRAM_SDQS0	H23	NVCC_EMI_DRAM	DDR3CLK	ALT0	EXTMC	emi_DRAM_SD QS[0]	Input	Low
DRAM_SDQS0_B	H22	NVCC_EMI_DRAM	DDR3CLK	ALT0	EXTMC	emi_DRAM_SD QS_B[0]	Input	High
DRAM_SDQS1	D23	NVCC_EMI_DRAM	DDR3CLK	ALT0	EXTMC	emi_DRAM_SD QS[1]	Input	Low
DRAM_SDQS1_B	D22	NVCC_EMI_DRAM	DDR3CLK	ALT0	EXTMC	emi_DRAM_SD QS_B[1]	Input	High
DRAM_SDQS2	T22	NVCC_EMI_DRAM	DDR3CLK	ALT0	EXTMC	emi_DRAM_SD QS[2]	Input	Low
DRAM_SDQS2_B	T23	NVCC_EMI_DRAM	DDR3CLK	ALT0	EXTMC	emi_DRAM_SD QS_B[2]	Input	High
DRAM_SDQS3	Y22	NVCC_EMI_DRAM	DDR3CLK	ALT0	EXTMC	emi_DRAM_SD QS[3]	Input	Low
DRAM_SDQS3_B	Y23	NVCC_EMI_DRAM	DDR3CLK	ALT0	EXTMC	emi_DRAM_SD QS_B[3]	Input	High
DRAM_SDWE	L19	NVCC_EMI_DRAM	DDR3	ALT0	EXTMC	emi_DRAM_SD WE	Output	High
ECKIL	AC10	NVCC_SRTC_POW	ANALOG	—	SRTC	ECKIL {no block I/O by this name in RM}	—	—
EIM_A16	AA5	NVCC_EIM_MAIN	UHVIO	ALT0	EXTMC	emi_EIM_A[16]	Output ²	—
EIM_A17	V7	NVCC_EIM_MAIN	UHVIO	ALT0	EXTMC	emi_EIM_A[17]	Output ²	—
EIM_A18	AB3	NVCC_EIM_MAIN	UHVIO	ALT0	EXTMC	emi_EIM_A[18]	Output ²	—
EIM_A19	W7	NVCC_EIM_MAIN	UHVIO	ALT0	EXTMC	emi_EIM_A[19]	Output ²	—
EIM_A20	Y6	NVCC_EIM_MAIN	UHVIO	ALT0	EXTMC	emi_EIM_A[20]	Output ²	—
EIM_A21	AA4	NVCC_EIM_MAIN	UHVIO	ALT0	EXTMC	emi_EIM_A[21]	Output ²	—
EIM_A22	AA3	NVCC_EIM_MAIN	UHVIO	ALT0	EXTMC	emi_EIM_A[22]	Output ²	—
EIM_A23	V6	NVCC_EIM_MAIN	UHVIO	ALT0	EXTMC	emi_EIM_A[23]	Output	—
EIM_A24	Y5	NVCC_EIM_MAIN	UHVIO	ALT0	EXTMC	emi_EIM_A[24]	Output	—
EIM_A25	W6	NVCC_EIM_MAIN	UHVIO	ALT0	EXTMC	emi_EIM_A[25]	Output	—
EIM_BCLK	W11	NVCC_EIM_MAIN	UHVIO	ALT0	EXTMC	emi_EIM_BCLK	Output	—

Table 114. 19 x 19 mm Signal Assignments, Power Rails, and I/O (continued)

Contact Name	Contact Assignment	Power Rail	I/O Buffer Type	Out of Reset Condition ¹				
				Alt. Mode	Block Instance	Block I/O	Direction	Config. Value
EIM_CS0	W8	NVCC_EIM_MAIN	UHVIO	ALT0	EXTMC	emi_EIM_CS[0]	Output	—
EIM_CS1	Y7	NVCC_EIM_MAIN	UHVIO	ALT0	EXTMC	emi_EIM_CS[1]	Output	—
EIM_D16	U6	NVCC_EIM_SEC	UHVIO	ALT1	GPIO-3	gpio3_GPIO[16]	Input	100 KΩ PU
EIM_D17	U5	NVCC_EIM_SEC	UHVIO	ALT1	GPIO-3	gpio3_GPIO[17]	Input	100 KΩ PU
EIM_D18	V1	NVCC_EIM_SEC	UHVIO	ALT1	GPIO-3	gpio3_GPIO[18]	Input	100 KΩ PU
EIM_D19	V2	NVCC_EIM_SEC	UHVIO	ALT1	GPIO-3	gpio3_GPIO[19]	Input	100 KΩ PU
EIM_D20	W1	NVCC_EIM_SEC	UHVIO	ALT1	GPIO-3	gpio3_GPIO[20]	Input	100 KΩ PU
EIM_D21	V3	NVCC_EIM_SEC	UHVIO	ALT1	GPIO-3	gpio3_GPIO[21]	Input	100 KΩ PU
EIM_D22	W2	NVCC_EIM_SEC	UHVIO	ALT1	GPIO-3	gpio3_GPIO[22]	Input	360 KΩ PD
EIM_D23	Y1	NVCC_EIM_SEC	UHVIO	ALT1	GPIO-3	gpio3_GPIO[23]	Input	100 KΩ PU
EIM_D24	Y2	NVCC_EIM_SEC	UHVIO	ALT1	GPIO-3	gpio3_GPIO[24]	Input	100 KΩ PU
EIM_D25	W3	NVCC_EIM_SEC	UHVIO	ALT1	GPIO-3	gpio3_GPIO[25]	Input	100 KΩ PU
EIM_D26	V5	NVCC_EIM_SEC	UHVIO	ALT1	GPIO-3	gpio3_GPIO[26]	Input	100 KΩ PU
EIM_D27	V4	NVCC_EIM_SEC	UHVIO	ALT1	GPIO-3	gpio3_GPIO[27]	Input	100 KΩ PU
EIM_D28	AA1	NVCC_EIM_SEC	UHVIO	ALT1	GPIO-3	gpio3_GPIO[28]	Input	100 KΩ PU
EIM_D29	AA2	NVCC_EIM_SEC	UHVIO	ALT1	GPIO-3	gpio3_GPIO[29]	Input	100 KΩ PU
EIM_D30	W4	NVCC_EIM_SEC	UHVIO	ALT1	GPIO-3	gpio3_GPIO[30]	Input	100 KΩ PU
EIM_D31	W5	NVCC_EIM_SEC	UHVIO	ALT1	GPIO-3	gpio3_GPIO[31]	Input	360 KΩ PD
EIM_DA0	Y8	NVCC_EIM_MAIN	UHVIO	ALT0	EXTMC	emi_NAND_EIM_DA[0]	Input ²	100 KΩ PU
EIM_DA1	AC4	NVCC_EIM_MAIN	UHVIO	ALT0	EXTMC	emi_NAND_EIM_DA[1]	Input ²	100 KΩ PU

Table 114. 19 x 19 mm Signal Assignments, Power Rails, and I/O (continued)

Contact Name	Contact Assignment	Power Rail	I/O Buffer Type	Out of Reset Condition ¹				
				Alt. Mode	Block Instance	Block I/O	Direction	Config. Value
EIM_DA10	AB7	NVCC_EIM_MAIN	UHVIO	ALT0	EXTMC	emi_NAND_EIM_DA[10]	Input ²	100 K Ω PU
EIM_DA11	AC6	NVCC_EIM_MAIN	UHVIO	ALT0	EXTMC	emi_NAND_EIM_DA[11]	Input	100 K Ω PU
EIM_DA12	V10	NVCC_EIM_MAIN	UHVIO	ALT0	EXTMC	emi_NAND_EIM_DA[12]	Input	100 K Ω PU
EIM_DA13	AC7	NVCC_EIM_MAIN	UHVIO	ALT0	EXTMC	emi_NAND_EIM_DA[13]	Input	100 K Ω PU
EIM_DA14	Y10	NVCC_EIM_MAIN	UHVIO	ALT0	EXTMC	emi_NAND_EIM_DA[14]	Input	100 K Ω PU
EIM_DA15	AA9	NVCC_EIM_MAIN	UHVIO	ALT0	EXTMC	emi_NAND_EIM_DA[15]	Input	100 K Ω PU
EIM_DA2	AA7	NVCC_EIM_MAIN	UHVIO	ALT0	EXTMC	emi_NAND_EIM_DA[2]	Input ²	100 K Ω PU
EIM_DA3	W9	NVCC_EIM_MAIN	UHVIO	ALT0	EXTMC	emi_NAND_EIM_DA[3]	Input ²	100 K Ω PU
EIM_DA4	AB6	NVCC_EIM_MAIN	UHVIO	ALT0	EXTMC	emi_NAND_EIM_DA[4]	Input ²	100 K Ω PU
EIM_DA5	V9	NVCC_EIM_MAIN	UHVIO	ALT0	EXTMC	emi_NAND_EIM_DA[5]	Input ²	100 K Ω PU
EIM_DA6	Y9	NVCC_EIM_MAIN	UHVIO	ALT0	EXTMC	emi_NAND_EIM_DA[6]	Input ²	100 K Ω PU
EIM_DA7	AC5	NVCC_EIM_MAIN	UHVIO	ALT0	EXTMC	emi_NAND_EIM_DA[7]	Input ²	100 K Ω PU
EIM_DA8	AA8	NVCC_EIM_MAIN	UHVIO	ALT0	EXTMC	emi_NAND_EIM_DA[8]	Input ²	100 K Ω PU
EIM_DA9	W10	NVCC_EIM_MAIN	UHVIO	ALT0	EXTMC	emi_NAND_EIM_DA[9]	Input ²	100 K Ω PU
EIM_EB0	AC3	NVCC_EIM_MAIN	UHVIO	ALT0	EXTMC	emi_EIM_EB[0]	Output ²	—
EIM_EB1	AB5	NVCC_EIM_MAIN	UHVIO	ALT0	EXTMC	emi_EIM_EB[1]	Output ²	—
EIM_EB2	Y3	NVCC_EIM_MAIN	UHVIO	ALT1	GPIO-2	gpio2_GPIO[30]	Input	100 K Ω PU
EIM_EB3	Y4	NVCC_EIM_MAIN	UHVIO	ALT1	GPIO-2	gpio2_GPIO[31]	Input	100 K Ω PU
EIM_LBA	AA6	NVCC_EIM_MAIN	UHVIO	ALT0	EXTMC	emi_EIM_LBA	Output ²	—
EIM_OE	V8	NVCC_EIM_MAIN	UHVIO	ALT0	EXTMC	emi_EIM_OE	Output	—
EIM_RW	AB4	NVCC_EIM_MAIN	UHVIO	ALT0	EXTMC	emi_EIM_RW	Output	—

Table 114. 19 x 19 mm Signal Assignments, Power Rails, and I/O (continued)

Contact Name	Contact Assignment	Power Rail	I/O Buffer Type	Out of Reset Condition ¹				
				Alt. Mode	Block Instance	Block I/O	Direction	Config. Value
EIM_WAIT	AB9	NVCC_EIM_MAIN	UHVIO	ALT0	EXTMC	emi_EIM_WAIT	Output	—
EXTAL	AB11	NVCC_XTAL	ANALOG	—	EXTALOSC	EXTAL	—	—
FASTR_ANA	E18	NVCC_CKIH	ANALOG	—	—	(reserved, tie to ground)	—	—
FASTR_DIG	E17	NVCC_CKIH	ANALOG	—	—	(reserved, tie to ground)	—	—
FEC_CRS_DV	D11	NVCC_FEC	UHVIO	ALT1	GPIO-1	gpio1_GPIO[25]	Input	100 KΩ PU
FEC_MDC	E10	NVCC_FEC	UHVIO	ALT1	GPIO-1	gpio1_GPIO[31]	Input	100 KΩ PU
FEC_MDIO	D12	NVCC_FEC	UHVIO	ALT1	GPIO-1	gpio1_GPIO[22]	Input	100 KΩ PU
FEC_REF_CLK	E12	NVCC_FEC	UHVIO	ALT1	GPIO-1	gpio1_GPIO[23]	Input	100 KΩ PU
FEC_RX_ER	F12	NVCC_FEC	UHVIO	ALT1	GPIO-1	gpio1_GPIO[24]	Input	100 KΩ PU
FEC_RXD0	C11	NVCC_FEC	UHVIO	ALT1	GPIO-1	gpio1_GPIO[27]	Input	100 KΩ PU
FEC_RXD1	E11	NVCC_FEC	UHVIO	ALT1	GPIO-1	gpio1_GPIO[26]	Input	100 KΩ PU
FEC_TX_EN	C10	NVCC_FEC	UHVIO	ALT1	GPIO-1	gpio1_GPIO[28]	Input	360 KΩ PD
FEC_TXD0	F10	NVCC_FEC	UHVIO	ALT1	GPIO-1	gpio1_GPIO[30]	Input	100 KΩ PU
FEC_TXD1	D10	NVCC_FEC	UHVIO	ALT1	GPIO-1	gpio1_GPIO[29]	Input	100 KΩ PU
GPIO_0	C8	NVCC_GPIO	UHVIO	ALT1	GPIO-1	gpio1_GPIO[0]	Input	360 KΩ PD
GPIO_1	B7	NVCC_GPIO	UHVIO	ALT1	GPIO-1	gpio1_GPIO[1]	Input	360 KΩ PD
GPIO_10	W16	TVDAC_AHVDDRB	GPIO	ALT0	GPIO-4	gpio4_GPIO[0]	Input	100 KΩ PU
GPIO_11	V17	TVDAC_AHVDDRB	GPIO	ALT0	GPIO-4	gpio4_GPIO[1]	Input	100 KΩ PU
GPIO_12	W17	TVDAC_AHVDDRB	GPIO	ALT0	GPIO-4	gpio4_GPIO[2]	Input	100 KΩ PU

Table 114. 19 x 19 mm Signal Assignments, Power Rails, and I/O (continued)

Contact Name	Contact Assignment	Power Rail	I/O Buffer Type	Out of Reset Condition ¹				
				Alt. Mode	Block Instance	Block I/O	Direction	Config. Value
GPIO_13	AA18	TVDAC_AHVDDRB	GPIO	ALT0	GPIO-4	gpio4_GPIO[3]	Input	100 K Ω PU
GPIO_14	W18	TVDAC_AHVDDRB	GPIO	ALT0	GPIO-4	gpio4_GPIO[4]	Input	100 K Ω PU
GPIO_16	C6	NVCC_GPIO	UHvio	ALT1	GPIO-7	gpio7_GPIO[11]	Input	360 K Ω PD
GPIO_17	A3	NVCC_GPIO	UHvio	ALT1	GPIO-7	gpio7_GPIO[12]	Input	360 K Ω PD
GPIO_18	D7	NVCC_GPIO	UHvio	ALT1	GPIO-7	gpio7_GPIO[13]	Input	360 K Ω PD
GPIO_19	B4	NVCC_KEYPAD	UHvio	ALT1	GPIO-4	gpio4_GPIO[5]	Input ³	100 K Ω PU
GPIO_2	C7	NVCC_GPIO	UHvio	ALT1	GPIO-1	gpio1_GPIO[2]	Input	360 K Ω PD
GPIO_3	A6	NVCC_GPIO	UHvio	ALT1	GPIO-1	gpio1_GPIO[3]	Input	360 K Ω PD
GPIO_4	D8	NVCC_GPIO	UHvio	ALT1	GPIO-1	gpio1_GPIO[4]	Input	100 K Ω PU
GPIO_5	A5	NVCC_GPIO	UHvio	ALT1	GPIO-1	gpio1_GPIO[5]	Input	360 K Ω PD
GPIO_6	B6	NVCC_GPIO	UHvio	ALT1	GPIO-1	gpio1_GPIO[6]	Input	360 K Ω PD
GPIO_7	A4	NVCC_GPIO	UHvio	ALT1	GPIO-1	gpio1_GPIO[7]	Input	360 K Ω PD
GPIO_8	B5	NVCC_GPIO	UHvio	ALT1	GPIO-1	gpio1_GPIO[8]	Input	360 K Ω PD
GPIO_9	E8	NVCC_GPIO	UHvio	ALT1	GPIO-1	gpio1_GPIO[9]	Input	100 K Ω PU
JTAG_MOD	C9	NVCC_JTAG	GPIO	ALT0	SJC	sjc_MOD	Input	100 K Ω PU
JTAG_TCK	D9	NVCC_JTAG	GPIO	ALT0	SJC	sjc_TCK	Input	100 K Ω PD
JTAG_TDI	B8	NVCC_JTAG	GPIO	ALT0	SJC	sjc_TDI	Input	47 K Ω PU
JTAG_TDO	A7	NVCC_JTAG	GPIO	ALT0	SJC	sjc_TDO	Input	Keeper
JTAG_TMS	A8	NVCC_JTAG	GPIO	ALT0	SJC	sjc_TMS	Input	47 K Ω PU

Table 114. 19 x 19 mm Signal Assignments, Power Rails, and I/O (continued)

Contact Name	Contact Assignment	Power Rail	I/O Buffer Type	Out of Reset Condition ¹				
				Alt. Mode	Block Instance	Block I/O	Direction	Config. Value
JTAG_TRSTB	E9	NVCC_JTAG	GPIO	ALT0	SJC	sjc_TRSTB	Input	47 KΩ PU
KEY_COL0	C5	NVCC_KEYPAD	UHVIO	ALT1	GPIO-4	gpio4_GPIO[6]	Input ⁴	100 KΩ PU
KEY_COL1	E7	NVCC_KEYPAD	UHVIO	ALT1	GPIO-4	gpio4_GPIO[8]	Input	100 KΩ PU
KEY_COL2	C4	NVCC_KEYPAD	UHVIO	ALT1	GPIO-4	gpio4_GPIO[10]	Input	100 KΩ PU
KEY_COL3	F6	NVCC_KEYPAD	UHVIO	ALT1	GPIO-4	gpio4_GPIO[12]	Input	100 KΩ PU
KEY_COL4	E5	NVCC_KEYPAD	UHVIO	ALT1	GPIO-4	gpio4_GPIO[14]	Input	100 KΩ PU
KEY_ROW0	B3	NVCC_KEYPAD	UHVIO	ALT1	GPIO-4	gpio4_GPIO[7]	Input	360 KΩ PD
KEY_ROW1	D6	NVCC_KEYPAD	UHVIO	ALT1	GPIO-4	gpio4_GPIO[9]	Input	100 KΩ PU
KEY_ROW2	D5	NVCC_KEYPAD	UHVIO	ALT1	GPIO-4	gpio4_GPIO[11]	Input	100 KΩ PU
KEY_ROW3	D4	NVCC_KEYPAD	UHVIO	ALT1	GPIO-4	gpio4_GPIO[13]	Input	100 KΩ PU
KEY_ROW4	E6	NVCC_KEYPAD	UHVIO	ALT1	GPIO-4	gpio4_GPIO[15]	Input	360 KΩ PD
LVDS_BG_RES	AA14	NVCC_LVDS_BG	ANALOG	—	LDB	LVDS_BG_RES	—	—
LVDS0_CLK_N	AB16	NVCC_LVDS	LVDS	ALT0	GPIO-7	gpio7_GPI[25]	Input	Floating
LVDS0_CLK_P	AC16	NVCC_LVDS	LVDS	ALT0	GPIO-7	gpio7_GPI[24]	Input	Floating
LVDS0_TX0_N	Y17	NVCC_LVDS	LVDS	ALT0	GPIO-7	gpio7_GPI[31]	Input	Floating
LVDS0_TX0_P	AA17	NVCC_LVDS	LVDS	ALT0	GPIO-7	gpio7_GPI[30]	Input	Floating
LVDS0_TX1_N	AB17	NVCC_LVDS	LVDS	ALT0	GPIO-7	gpio7_GPI[29]	Input	Floating
LVDS0_TX1_P	AC17	NVCC_LVDS	LVDS	ALT0	GPIO-7	gpio7_GPI[28]	Input	Floating
LVDS0_TX2_N	Y16	NVCC_LVDS	LVDS	ALT0	GPIO-7	gpio7_GPI[27]	Input	Floating
LVDS0_TX2_P	AA16	NVCC_LVDS	LVDS	ALT0	GPIO-7	gpio7_GPI[26]	Input	Floating
LVDS0_TX3_N	AB15	NVCC_LVDS	LVDS	ALT0	GPIO-7	gpio7_GPI[23]	Input	Floating
LVDS0_TX3_P	AC15	NVCC_LVDS	LVDS	ALT0	GPIO-7	gpio7_GPI[22]	Input	Floating
LVDS1_CLK_N	AA13	NVCC_LVDS	LVDS	ALT0	GPIO-6	gpio6_GPI[27]	Input	Floating
LVDS1_CLK_P	Y13	NVCC_LVDS	LVDS	ALT0	GPIO-6	gpio6_GPI[26]	Input	Floating

Table 114. 19 x 19 mm Signal Assignments, Power Rails, and I/O (continued)

Contact Name	Contact Assignment	Power Rail	I/O Buffer Type	Out of Reset Condition ¹				
				Alt. Mode	Block Instance	Block I/O	Direction	Config. Value
LVDS1_TX0_N	AC14	NVCC_LVDS	LVDS	ALT0	GPIO-6	gpio6_GPI[31]	Input	Floating
LVDS1_TX0_P	AB14	NVCC_LVDS	LVDS	ALT0	GPIO-6	gpio6_GPI[30]	Input	Floating
LVDS1_TX1_N	AC13	NVCC_LVDS	LVDS	ALT0	GPIO-6	gpio6_GPI[29]	Input	Floating
LVDS1_TX1_P	AB13	NVCC_LVDS	LVDS	ALT0	GPIO-6	gpio6_GPI[28]	Input	Floating
LVDS1_TX2_N	AC12	NVCC_LVDS	LVDS	ALT0	GPIO-6	gpio6_GPI[25]	Input	Floating
LVDS1_TX2_P	AB12	NVCC_LVDS	LVDS	ALT0	GPIO-6	gpio6_GPI[24]	Input	Floating
LVDS1_TX3_N	AA12	NVCC_LVDS	LVDS	ALT0	GPIO-6	gpio6_GPI[23]	Input	Floating
LVDS1_TX3_P	Y12	NVCC_LVDS	LVDS	ALT0	GPIO-6	gpio6_GPI[22]	Input	Floating
NANDF_ALE	Y11	NVCC_NANDF	UHVIO	ALT1	GPIO-6	gpio6_GPIO[8]	Input	100 K Ω PU
NANDF_CLE	AA10	NVCC_NANDF	UHVIO	ALT1	GPIO-6	gpio6_GPIO[7]	Input	100 K Ω PU
NANDF_CS0	W12	NVCC_NANDF	UHVIO	ALT1	GPIO-6	gpio6_GPIO[11]	Input	100 K Ω PU
NANDF_CS1	V13	NVCC_NANDF	UHVIO	ALT1	GPIO-6	gpio6_GPIO[14]	Input	100 K Ω PU
NANDF_CS2	V14	NVCC_NANDF	UHVIO	ALT1	GPIO-6	gpio6_GPIO[15]	Input	100 K Ω PU
NANDF_CS3	W13	NVCC_NANDF	UHVIO	ALT1	GPIO-6	gpio6_GPIO[16]	Input	100 K Ω PU
NANDF_RB0	U11	NVCC_NANDF	UHVIO	ALT1	GPIO-6	gpio6_GPIO[10]	Input	100 K Ω PU
NANDF_RE_B	AC8	NVCC_EIM_MAIN	UHVIO	ALT1	GPIO-6	gpio6_GPIO[13]	Input	100 K Ω PU
NANDF_WE_B	AB8	NVCC_EIM_MAIN	UHVIO	ALT1	GPIO-6	gpio6_GPIO[12]	Input	100 K Ω PU
NANDF_WP_B	AC9	NVCC_NANDF	UHVIO	ALT1	GPIO-6	gpio6_GPIO[9]	Input	100 K Ω PU
PATA_BUFFER_EN	K4	NVCC_PATA	UHVIO	ALT1	GPIO-7	gpio7_GPIO[1]	Input	100 K Ω PU
PATA_CS_0	L5	NVCC_PATA	UHVIO	ALT1	GPIO-7	gpio7_GPIO[9]	Input	100 K Ω PU
PATA_CS_1	L2	NVCC_PATA	UHVIO	ALT1	GPIO-7	gpio7_GPIO[10]	Input	100 K Ω PU
PATA_DA_0	K6	NVCC_PATA	UHVIO	ALT1	GPIO-7	gpio7_GPIO[6]	Input	100 K Ω PU

Table 114. 19 x 19 mm Signal Assignments, Power Rails, and I/O (continued)

Contact Name	Contact Assignment	Power Rail	I/O Buffer Type	Out of Reset Condition ¹				
				Alt. Mode	Block Instance	Block I/O	Direction	Config. Value
PATA_DA_1	L3	NVCC_PATA	UHVIO	ALT1	GPIO-7	gpio7_GPIO[7]	Input	100 KΩ PU
PATA_DA_2	L4	NVCC_PATA	UHVIO	ALT1	GPIO-7	gpio7_GPIO[8]	Input	100 KΩ PU
PATA_DATA0	L1	NVCC_PATA	UHVIO	ALT1	GPIO-2	gpio2_GPIO[0]	Input	100 KΩ PU
PATA_DATA1	M1	NVCC_PATA	UHVIO	ALT1	GPIO-2	gpio2_GPIO[1]	Input	100 KΩ PU
PATA_DATA10	N4	NVCC_PATA	UHVIO	ALT1	GPIO-2	gpio2_GPIO[10]	Input	100 KΩ PU
PATA_DATA11	M6	NVCC_PATA	UHVIO	ALT1	GPIO-2	gpio2_GPIO[11]	Input	100 KΩ PU
PATA_DATA12	N5	NVCC_PATA	UHVIO	ALT1	GPIO-2	gpio2_GPIO[12]	Input	100 KΩ PU
PATA_DATA13	N6	NVCC_PATA	UHVIO	ALT1	GPIO-2	gpio2_GPIO[13]	Input	100 KΩ PU
PATA_DATA14	P6	NVCC_PATA	UHVIO	ALT1	GPIO-2	gpio2_GPIO[14]	Input	100 KΩ PU
PATA_DATA15	P5	NVCC_PATA	UHVIO	ALT1	GPIO-2	gpio2_GPIO[15]	Input	100 KΩ PU
PATA_DATA2	L6	NVCC_PATA	UHVIO	ALT1	GPIO-2	gpio2_GPIO[2]	Input	100 KΩ PU
PATA_DATA3	M2	NVCC_PATA	UHVIO	ALT1	GPIO-2	gpio2_GPIO[3]	Input	100 KΩ PU
PATA_DATA4	M3	NVCC_PATA	UHVIO	ALT1	GPIO-2	gpio2_GPIO[4]	Input	100 KΩ PU
PATA_DATA5	M4	NVCC_PATA	UHVIO	ALT1	GPIO-2	gpio2_GPIO[5]	Input	100 KΩ PU
PATA_DATA6	N1	NVCC_PATA	UHVIO	ALT1	GPIO-2	gpio2_GPIO[6]	Input	100 KΩ PU
PATA_DATA7	M5	NVCC_PATA	UHVIO	ALT1	GPIO-2	gpio2_GPIO[7]	Input	100 KΩ PU
PATA_DATA8	N2	NVCC_PATA	UHVIO	ALT1	GPIO-2	gpio2_GPIO[8]	Input	100 KΩ PU
PATA_DATA9	N3	NVCC_PATA	UHVIO	ALT1	GPIO-2	gpio2_GPIO[9]	Input	100 KΩ PU
PATA_DIOR	K3	NVCC_PATA	UHVIO	ALT1	GPIO-7	gpio7_GPIO[3]	Input	100 KΩ PU

Table 114. 19 x 19 mm Signal Assignments, Power Rails, and I/O (continued)

Contact Name	Contact Assignment	Power Rail	I/O Buffer Type	Out of Reset Condition ¹				
				Alt. Mode	Block Instance	Block I/O	Direction	Config. Value
PATA_DIOW	J3	NVCC_PATA	UHVIO	ALT1	GPIO-6	gpio6_GPIO[17]	Input	100 K Ω PU
PATA_DMACK	J2	NVCC_PATA	UHVIO	ALT1	GPIO-6	gpio6_GPIO[18]	Input	100 K Ω PU
PATA_DMARQ	J1	NVCC_PATA	UHVIO	ALT1	GPIO-7	gpio7_GPIO[0]	Input	100 K Ω PU
PATA_INTRQ	K5	NVCC_PATA	UHVIO	ALT1	GPIO-7	gpio7_GPIO[2]	Input	100 K Ω PU
PATA_IORDY	K1	NVCC_PATA	UHVIO	ALT1	GPIO-7	gpio7_GPIO[5]	Input	100 K Ω PU
PATA_RESET_B	K2	NVCC_PATA	UHVIO	ALT1	GPIO-7	gpio7_GPIO[4]	Input	100 K Ω PU
PMIC_ON_REQ	W14	NVCC_SRTC_POW	GPIO	ALT0	SRTC	srtc_SRTCALAR M	Output	—
PMIC_STBY_REQ	W15	NVCC_SRTC_POW	GPIO	ALT0	CCM	ccm_PMIC_VST BY_REQ	Output	—
POR_B	C19	NVCC_RESET	LVIO	ALT0	SRC	src_POR_B	Input	100 K Ω PU
RESET_IN_B	A21	NVCC_RESET	LVIO	ALT0	SRC	src_RESET_B	Input	100 K Ω PU
SATA_REFCLKM	A14	VPH	ANALOG	—	SATA	SATA_REFCLK M	—	—
SATA_REFCLKP	B14	VPH	ANALOG	—	SATA	SATA_REFCLK P	—	—
SATA_REXT	C13	VPH	ANALOG	—	SATA	SATA_REXT	—	—
SATA_RXM	A12	VPH	ANALOG	—	SATA	SATA_RXM	—	—
SATA_RXP	B12	VPH	ANALOG	—	SATA	SATA_RXP	—	—
SATA_TXM	B10	VPH	ANALOG	—	SATA	SATA_TXM	—	—
SATA_TXP	A10	VPH	ANALOG	—	SATA	SATA_TXP	—	—
SD1_CLK	E16	NVCC_SD1	UHVIO	ALT1	GPIO-1	gpio1_GPIO[20]	Input	100 K Ω PU
SD1_CMD	F18	NVCC_SD1	UHVIO	ALT1	GPIO-1	gpio1_GPIO[18]	Input	100 K Ω PU
SD1_DATA0	A20	NVCC_SD1	UHVIO	ALT1	GPIO-1	gpio1_GPIO[16]	Input	100 K Ω PU
SD1_DATA1	C17	NVCC_SD1	UHVIO	ALT1	GPIO-1	gpio1_GPIO[17]	Input	100 K Ω PU

Table 114. 19 x 19 mm Signal Assignments, Power Rails, and I/O (continued)

Contact Name	Contact Assignment	Power Rail	I/O Buffer Type	Out of Reset Condition ¹				
				Alt. Mode	Block Instance	Block I/O	Direction	Config. Value
SD1_DATA2	F17	NVCC_SD1	UHVIO	ALT1	GPIO-1	gpio1_GPIO[19]	Input	100 KΩ PU
SD1_DATA3	F16	NVCC_SD1	UHVIO	ALT1	GPIO-1	gpio1_GPIO[21]	Input	100 KΩ PU
SD2_CLK	E14	NVCC_SD2	UHVIO	ALT1	GPIO-1	gpio1_GPIO[10]	Input	100 KΩ PU
SD2_CMD	C15	NVCC_SD2	UHVIO	ALT1	GPIO-1	gpio1_GPIO[11]	Input	100 KΩ PU
SD2_DATA0	D13	NVCC_SD2	UHVIO	ALT1	GPIO-1	gpio1_GPIO[15]	Input	100 KΩ PU
SD2_DATA1	C14	NVCC_SD2	UHVIO	ALT1	GPIO-1	gpio1_GPIO[14]	Input	100 KΩ PU
SD2_DATA2	D14	NVCC_SD2	UHVIO	ALT1	GPIO-1	gpio1_GPIO[13]	Input	100 KΩ PU
SD2_DATA3	E13	NVCC_SD2	UHVIO	ALT1	GPIO-1	gpio1_GPIO[12]	Input	100 KΩ PU
TEST_MODE	D17	NVCC_RESET	LVIO	ALT0		tcu_TEST_MOD E	Input	100 KΩ PD
TVCDC_I0B_BA CK	AB19	TVDAC_AHVDDRG B	ANALOG	—	TVE	TVCDC_I0B_B ACK	—	—
TVCDC_I0G_BA CK	AC20	TVDAC_AHVDDRG B	ANALOG	—	TVE	TVCDC_I0G_B ACK	—	—
TVCDC_I0R_BA CK	AB21	TVDAC_AHVDDRG B	ANALOG	—	TVE	TVCDC_I0R_B ACK	—	—
TVDAC_COMP	AA19	TVDAC_AHVDDRG B	ANALOG	—	TVE	TVDAC_COMP	—	—
TVDAC_I0B	AC19	TVDAC_AHVDDRG B	ANALOG	—	TVE	TVDAC_I0B	—	—
TVDAC_I0G	AB20	TVDAC_AHVDDRG B	ANALOG	—	TVE	TVDAC_I0G	—	—
TVDAC_I0R	AC21	TVDAC_AHVDDRG B	ANALOG	—	TVE	TVDAC_I0R	—	—
TVDAC_VREF	Y18	TVDAC_AHVDDRG B	ANALOG	—	TVE	TVDAC_VREF	—	—
USB_H1_DN	B17	USB_H1_VDDA25, USB_H1_VDDA33	ANALOG5 0	—	USB	USB_H1_DN	—	—
USB_H1_DP	A17	USB_H1_VDDA25, USB_H1_VDDA33	ANALOG5 0	—	USB	USB_H1_DP	—	—

Table 114. 19 x 19 mm Signal Assignments, Power Rails, and I/O (continued)

Contact Name	Contact Assignment	Power Rail	I/O Buffer Type	Out of Reset Condition ¹				
				Alt. Mode	Block Instance	Block I/O	Direction	Config. Value
USB_H1_GPANAIO	A16	USB_H1_VDDA25, USB_H1_VDDA33	ANALOG2 5	—	USB	USB_H1_GPANAIO	—	—
USB_H1_RREFEXT	B16	USB_H1_VDDA25, USB_H1_VDDA33	ANALOG2 5	—	USB	USB_H1_RREFEXT	—	—
USB_H1_VBUS	D15	USB_H1_VDDA25, USB_H1_VDDA33	ANALOG5 0	—	USB	USB_H1_VBUS	—	—
USB_OTG_DN	A19	USB_OTG_VDDA25, USB_OTG_VDDA33	ANALOG5 0	—	USB	USB_OTG_DN	—	—
USB_OTG_DP	B19	USB_OTG_VDDA25, USB_OTG_VDDA33	ANALOG5 0	—	USB	USB_OTG_DP	—	—
USB_OTG_GPANAIO	F15	USB_OTG_VDDA25, USB_OTG_VDDA33	ANALOG2 5	—	USB	USB_OTG_GPANAIO	—	—
USB_OTG_ID	C16	USB_OTG_VDDA25, USB_OTG_VDDA33	ANALOG2 5	—	USB	USB_OTG_ID	—	—
USB_OTG_RREFEXT	D16	USB_OTG_VDDA25, USB_OTG_VDDA33	ANALOG2 5	—	USB	USB_OTG_RREFEXT	—	—
USB_OTG_VBUS	E15	USB_OTG_VDDA25, USB_OTG_VDDA33	ANALOG5 0	—	USB	USB_OTG_VBUS	—	—
XTAL	AC11	NVCC_XTAL	ANALOG	—	XTALOSC	XTAL	—	—

¹ The state immediately after reset and before ROM firmware or software has executed.

² During power-on reset, this port acts as input for fuse override. See [Section 5.1, “Boot Mode Configuration Pins”](#) for details. For appropriate resistor values, see Chapter 1 of *i.MX53 System Development User's Guide (MX53UG)*.

³ During power-on reset, this port acts as output for diagnostic signal INT_BOOT

⁴ During power-on reset, this port acts as output for diagnostic signal ANY_PU_RST

NOTE

KEY_COL0 and GPIO_19 act as output for diagnostic signals during power-on reset.

6.1.4 19 x 19 mm, 0.8 mm Pitch Ball Map

Table 115 shows the 19 × 19 mm, 0.8 mm pitch ball map.

Table 115. 19 x 19 mm, 0.8 mm Pitch Ball Map

F	E	D	C	B	A
DISP0_DAT3	DISP0_DAT13	DISP0_DAT16	DISP0_DAT21	GND	GND
DISP0_DAT14	DISP0_DAT9	DIO_PIN4	DIO_PIN3	SVDDGP	GND
DISP0_DAT15	DISP0_DAT22	DIO_PIN2	DISP0_DAT23	KEY_ROW0	GPIO_17
DISP0_DAT20	DIO_PIN15	KEY_ROW3	KEY_COL2	GPIO_19	GPIO_7
DISP0_DAT17	KEY_COL4	KEY_ROW2	KEY_COL0	GPIO_8	GPIO_5
KEY_COL3	KEY_ROW4	KEY_ROW1	GPIO_16	GPIO_6	GPIO_3
NVCC_KEYPAD	KEY_COL1	GPIO_18	GPIO_2	GPIO_1	JTAG_TDO
NVCC_GPIO	GPIO_9	GPIO_4	GPIO_0	JTAG_TDI	JTAG_TMS
VDDAL1	JTAG_TRSTB	JTAG_TCK	JTAG_MOD	VPH	VPH
FEC_TXD0	FEC_MDC	FEC_TXD1	FEC_TX_EN	SATA_TXM	SATA_TXP
NVCC_FEC	FEC_RXD1	FEC_CRS_DV	FEC_RXD0	GND	GND
FEC_RX_ER	FEC_REF_CLK	FEC_MDIO	GND	SATA_RXP	SATA_RXM
USB_H1_VDDA25	SD2_DATA3	SD2_DATA0	SATA_REXT	GND	GND
USB_OTG_VDDA25	SD2_CLK	SD2_DATA2	SD2_DATA1	SATA_REFCLKP	SATA_REFCLKM
USB_OTG_GPANAIO	USB_OTG_VBUS	USB_H1_VBUS	SD2_CMD	VP	VP
SD1_DATA3	SD1_CLK	USB_OTG_RREFEXT	USB_OTG_ID	USB_H1_RREFEXT	USB_H1_GPANAIO
SD1_DATA2	FASTR_DIG	TEST_MODE	SD1_DATA1	USB_H1_DN	USB_H1_DP
SD1_CMD	FASTR_ANA	CKIH2	BOOT_MODE0	GND	GND
GND	GND	GND	POR_B	USB_OTG_DP	USB_OTG_DN
GND	DRAM_DQM1	DRAM_D11	GND	BOOT_MODE1	SD1_DATA0
GND	DRAM_D8	DRAM_D9	GND	CKIH1	RESET_IN_B
GND	DRAM_D10	DRAM_SDQS1_B	DRAM_D15	SVCC	GND
DRAM_D14	DRAM_D12	DRAM_SDQS1	DRAM_D13	GND	GND
F	E	D	C	B	A

Table 115. 19 x 19 mm, 0.8 mm Pitch Ball Map (continued)

N	M	L	K	J	H	G
PATA_DATA6	PATA_DATA1	PATA_DATA0	PATA_IORDY	PATA_DMARQ	DISP0_DAT12	DISP0_DATA6
PATA_DATA8	PATA_DATA3	PATA_CS_1	PATA_RESET_B	PATA_DMACK	DISP0_DAT2	DISP0_DATA4
PATA_DATA9	PATA_DATA4	PATA_DA_1	PATA_DIOR	PATA_DIOW	DISP0_DAT5	DISP0_DATA10
PATA_DATA10	PATA_DATA5	PATA_DA_2	PATA_BUFFER_EN	DISP0_DAT1	DIO_DISP_CLK	DISP0_DATA18
PATA_DATA12	PATA_DATA7	PATA_CS_0	PATA_INTRQ	DISP0_DAT0	DISP0_DAT11	DISP0_DATA19
PATA_DATA13	PATA_DATA11	PATA_DATA2	PATA_DA_0	NVCC_LCD	DISP0_DAT7	DISP0_DATA8
NVCC_PATA	VDDA	GND	VDDGP	NVCC_LCD	VDDGP	GND
VCC	GND	VDDGP	GND	VDDGP	GND	VDDGP
GND	VCC	GND	VDDGP	GND	VDDGP	NVCC_JTAG
VCC	GND	VDDGP	GND	VDDGP	GND	VDDGP
GND	VCC	GND	VDDGP	GND	VDDGP	VDDGP
VCC	GND	VDDGP	GND	VDDGP	GND	VDDGP
GND	VCC	GND	VDDGP	GND	GND	VDDGP
VCC	GND	VCC	VCC	VCC	VCC	VDDA
GND	VCC	VCC	GND	GND	VCC	USB_H1_VDDA33
VCC	GND	VCC	GND	VCC	NVCC_SD2	USB_OTG_VDDA33
GND	VCC	GND	VCC	GND	NVCC_SD1	VDD_FUSE
VCC	GND	VCC	GND	VCC	NVCC_RESET	VDD_ANA_PLL
NVCC_EMI_DRAM	VDDA	DDR_VREF	NVCC_EMI_DRAM	GND	VDD_DIG_PLL	NVCC_CKIH
DRAM_A14	DRAM_A15	DRAM_CAS	DRAM_CS0	DRAM_SODT0	NVCC_EMI_DRAM	VDD_REG
DRAM_SDBA2	DRAM_A0	DRAM_SDWE	DRAM_A10	DRAM_RAS	DRAM_SDCKE0	GND
DRAM_A3	DRAM_A2	DRAM_A12	DRAM_A4	GND	DRAM_D0	DRAM_D3
DRAM_A5	DRAM_A9	DRAM_A1	GND	DRAM_D2	DRAM_DQM0	DRAM_D1
DRAM_A7	DRAM_A6	DRAM_A11	DRAM_SDCLK_0_B	DRAM_D6	DRAM_SDQS0_B	DRAM_D7
DRAM_A8	DRAM_CALIBRATION	DRAM_A13	DRAM_SDCLK_0	DRAM_D4	DRAM_SDQS0	DRAM_D5
N	M	L	K	J	H	G

Table 115. 19 x 19 mm, 0.8 mm Pitch Ball Map (continued)

Y	W	V	U	T	R	P
EIM_D23	EIM_D20	EIM_D18	CSIO_DAT14	CSIO_DAT8	CSIO_DAT4	CSIO_PIXCLK
EIM_D24	EIM_D22	EIM_D19	CSIO_DAT15	CSIO_DAT11	CSIO_DAT5	CSIO_MCLK
EIM_EB2	EIM_D25	EIM_D21	CSIO_DAT18	CSIO_DAT12	CSIO_DAT7	CSIO_DATA_EN
EIM_EB3	EIM_D30	EIM_D27	CSIO_DAT19	CSIO_DAT16	CSIO_DAT9	CSIO_VSYNC
EIM_A24	EIM_D31	EIM_D26	EIM_D17	CSIO_DAT17	CSIO_DAT10	PATA_DATA15
EIM_A20	EIM_A25	EIM_A23	EIM_D16	CSIO_DAT13	CSIO_DAT6	PATA_DATA14
EIM_CS1	EIM_A19	EIM_A17	NVCC_EIM_SEC	VCC	NVCC_CSI	GND
EIM_DA0	EIM_CS0	EIM_OE	VCC	GND	VCC	GND
EIM_DA6	EIM_DA3	EIM_DA5	NVCC_EIM_MAIN	VCC	GND	VCC
EIM_DA14	EIM_DA9	EIM_DA12	NVCC_EIM_MAIN	GND	VCC	GND
NANDF_ALE	EIM_BCLK	NVCC_SRTC_POW	NANDF_RB0	VCC	GND	VCC
LVDS1_TX3_P	NANDF_CS0	NVCC_XTAL	VDDA	NVCC_NANDF	VCC	GND
LVDS1_CLK_P	NANDF_CS3	NANDF_CS1	NVCC_LVDS	VCC	GND	VCC
GND	PMIC_ON_REQ	NANDF_CS2	NVCC_LVDS_BG	GND	VCC	GND
GND	PMIC_STBY_REQ	GND	GND	VCC	GND	VCC
LVDS0_TX2_N	GPIO_10	TVDAC_AHVD DRGB	TVDAC_DHVDD	GND	VCC	GND
LVDS0_TX0_N	GPIO_12	GPIO_11	TVDAC_AHVD DRGB	VCC	GND	NVCC_EMI_DRAM
TVDAC_VREF	GPIO_14	GND	VCC	NVCC_EMI_DRAM	DRAM_SDODT1	DRAM_RESET
GND	GND	GND	GND	DRAM_SDCKE1	DRAM_SDBA0	DRAM_CS1
DRAM_D24	DRAM_DQM3	GND	DRAM_D16	DRAM_DQM2	GND	DRAM_SDBA1
DRAM_D26	DRAM_D25	GND	DRAM_D18	DRAM_D17	DRAM_D19	GND
DRAM_SDQS3	DRAM_D27	GND	DRAM_D22	DRAM_SDQS2	DRAM_D21	DRAM_SDCLK_1
DRAM_SDQS3_B	DRAM_D31	DRAM_D29	DRAM_D20	DRAM_SDQS2_B	DRAM_D23	DRAM_SDCLK_1_B
Y	W	V	U	T	R	P

Table 115. 19 x 19 mm, 0.8 mm Pitch Ball Map (continued)

	AC	AB	AA
1	GND	GND	EIM_D28
2	GND	GND	EIM_D29
3	EIM_EB0	EIM_A18	EIM_A22
4	EIM_DA1	EIM_RW	EIM_A21
5	EIM_DA7	EIM_EB1	EIM_A16
6	EIM_DA11	EIM_DA4	EIM_LBA
7	EIM_DA13	EIM_DA10	EIM_DA2
8	NANDF_RE_B	NANDF_WE_B	EIM_DA8
9	NANDF_WP_B	EIM_WAIT	EIM_DA15
10	ECKIL	CKIL	NANDF_CLE
11	XTAL	EXTAL	GND
12	LVDS1_TX2_N	LVDS1_TX2_P	LVDS1_TX3_N
13	LVDS1_TX1_N	LVDS1_TX1_P	LVDS1_CLK_N
14	LVDS1_TX0_N	LVDS1_TX0_P	LVDS_BG_RES
15	LVDS0_TX3_P	LVDS0_TX3_N	GND
16	LVDS0_CLK_P	LVDS0_CLK_N	LVDS0_TX2_P
17	LVDS0_TX1_P	LVDS0_TX1_N	LVDS0_TX0_P
18	GND	GND	GPIO_13
19	TVDAC_I0B	TVCDC_I0B_BACK	TVDAC_COMP
20	TVCDC_I0G_BACK	TVDAC_I0G	GND
21	TVDAC_I0R	TVCDC_I0R_BACK	GND
22	GND	GND	DRAM_D30
23	GND	GND	DRAM_D28
	AC	AB	AA

7 Revision History

Table 117 provides a revision history for this data sheet.

Table 117. i.MX53 Data Sheet Document Revision History

Rev. Number	Date	Substantive Change(s)
Rev. 8	02/2021	<ul style="list-style-type: none"> Updated part numbers in Table 1., "Ordering Information. Updated package drawings in Section 6.1, "19x19 mm Package Information.
Rev. 7	05/2015	<ul style="list-style-type: none"> Updated mask set in Table 1. Added SRTC information and note on NVCC_RESET power in Section 4.2.1, "Power-Up Sequence". Added SRTC footnote to Figure 2.
Rev. 6	03/2013	<p>In Table 1, "Ordering Information" removed MCIMX535DVV2C, as it no longer exists.</p> <p>In Table 7, "i.MX53 Operating Ranges," updated minimum values of LVDS interface supply (NVCC_LVDS) and LVDS band gap supply (NVCC_LVDS_BG) to 2.375 volts.</p>
Rev. 5	09/2012	<ul style="list-style-type: none"> In Table 1, "Ordering Information," on page 2," renamed "Features" column as "CPU Frequency." In Section 1.2, "Features:" <ul style="list-style-type: none"> —Changed "SATA I" to "SATA II" under Hard disk drives bullet —Added a new bullet item to mention support for tamper detection mechanism In Section 1.2, "Features," added a new bullet item to mention support for FlexCAN feature. Removed the note shown at the end of Section 1.2, "Features." In Table 2, "i.MX53 Digital and Analog Blocks," on page 7, removed details of MPEG2 encoder, as this is not supported on i.MX53. In Table 7, "i.MX53 Operating Ranges," on page 18: <ul style="list-style-type: none"> —Changed VDDGP max voltage, for all frequency ranges and for STOP mode, to 1.15 V —Updated footnote on TVDAC_DHVDD and TVDAC_AHVDDRGB In Table 9, "Maximal Supply Currents," on page 20: <ul style="list-style-type: none"> —Corrected power line name, MVCC_XTAL, to NVCC_XTAL —Added a footnote on NVCC_EMI_DRAM —Updated max current value and added a footnote for power line, NVCC_SRTC_POW —Removed duplicate entries for NVCC_EMI_DRAM and NVCC_XTAL In Section 4.2.3, "Power Supplies Usage," updated the fourth bullet item. In Figure 25, "Asynchronous A/D Muxed Write Access," on page 58, renamed "WE41" as "WE41A" and shifted its position to left. In Table 60, "Camera Input Signal Cross Reference, Format and Bits Per Cycle," on page 80, added a footnote on "YCbCr 8 bits 2 cycles" column header.

Table 117. i.MX53 Data Sheet Document Revision History (continued)

Rev. Number	Date	Substantive Change(s)
Rev. 4	11/2011	<ul style="list-style-type: none"> • In Section 1, "Introduction," changed 1 GHz to 1.2 GHz in the second paragraph and updated the bulleted list after the second paragraph. • In Table 1, "Ordering Information," on page 2: <ul style="list-style-type: none"> —Removed part numbers "PCIMX535DVV1C" and "MCIMX538DZK1C" —Added a new part number "MCIMX535DVV2C" —Updated package information for part number "PCIMX538DZK1C" —Updated the second footnote • In Section 1.2, "Features," changed "Target frequency" to "Maximum frequency" and 1 GHz to 1–1.2 GHz in the third bullet item of the first bulleted list. • In Table 2, "i.MX53 Digital and Analog Blocks," on page 7, removed "Sorenson H.263 decode, 4CIF resolution, 8 Mbps bit rate" from VPU brief description. • In Table 5, "Absolute Maximum Ratings," on page 16, changed the maximum voltage for VDDGP from 1.35V to 1.4V. • In Table 7, "i.MX53 Operating Ranges," on page 18: <ul style="list-style-type: none"> —Added a row and a footnote for "ARM core supply voltage $f_{ARM} \leq 1200$ MHz" parameter of VDDGP —Added a new footnote for "Peripheral supply voltage" parameter of VCC —Updated the footnote for "Junction temperature" parameter <p>(continued on next page)</p>

Table 117. i.MX53 Data Sheet Document Revision History (continued)

Rev. Number	Date	Substantive Change(s)
Rev. 4	11/2011	<ul style="list-style-type: none"> • In Section 1, "Introduction," added a new bullet item, Applications processor, to the bulleted list that contains features of the i.MX53 processor. • In Section 1.2, "Features," changed "Target frequency" to "Maximum frequency" and added a new bullet item to mention support for the DVFS feature. • In Section 2.1, "Block Diagram," added Figure 1, "i.MX53 System Block Diagram," on page 6. • In Table 2, "i.MX53 Digital and Analog Blocks," on page 7, removed "Sorenson H.263 decode, 4CIF resolution, 8 Mbps bit rate" from VPU brief description. • Added a note after Section 4.2.1, "Power-Up Sequence," cross-referencing i.MX53 System Development User's Guide. • In Table 11, "GPIO I/O DC Electrical Characteristics," on page 27: <ul style="list-style-type: none"> —Changed test condition "Iout = -1 mA" to "Iout = -0.8 mA" in the first row —Removed test condition "Iout= specified Ioh Drive" from the first row —Removed "0.8 x OVDD" from the Min column of the first row —Changed test condition "Iout = 1 mA" to "Iout = 0.8 mA" in the second row —Removed test condition "Iout= specified Iol Drive" from the second row —Removed "0.2 x OVDD" from the Max column of the second row —Removed rows 3–6 —Changed the max value for Iin at condition "Vin = OVDD or 0" in row 12 from 2 μA to 10 μA —Changed the max value for Iin at condition "Vin = OVDD" in rows 13–15 from 2 μA to 10 μA —Changed the max value for Iin at condition "Vin = 0 V" in row 15 from 36 μA to 40 μA —Changed the max value for Iin at condition "Vin = 0 V" in row 16 from 2 μA to 10 μA —Changed the max value for Iin at condition "Vin = OVDD" in row 16 from 36 μA to 40 μA • In Table 12, "DDR2 I/O DC Electrical Parameters," on page 28: <ul style="list-style-type: none"> —Added test condition "Ioh = -0.1 mA" in the first row —Added test condition "Iol = 0.1 mA" in the second row —Removed rows 3–4 • In Section 4, "Electrical Characteristics," removed the note appearing after the first paragraph. • In Section 4.2.1, "Power-Up Sequence," updated the fifth bullet item to specify that VDD_ANA_PLL can be used to power NVCC_CKIH and NVCC_RESET. • In Section 4.3.2.2, "LPDDR2 Mode I/O DC Parameters," added the sentence "The parameters in Table 13 are guaranteed per the operating ranges in Table 7, unless otherwise noted." before Table 13. • In Table 13, "LPDDR2 I/O DC Electrical Parameters," on page 29: <ul style="list-style-type: none"> —Added test condition "Ioh = -0.1 mA" in the first row —Added test condition "Iol = 0.1 mA" in the second row • In Table 14, "DDR3 I/O DC Electrical Parameters," on page 29: <ul style="list-style-type: none"> —Added test condition "Ioh = -0.1 mA" in the first row —Added test condition "Iol = 0.1 mA" in the second row • In Table 15, "LVIO DC Electrical Characteristics," on page 30: <ul style="list-style-type: none"> —Added test condition "Ioh = -0.8 mA" in the first row —Added test condition "Iol = 0.8 mA" in the second row • In Table 16, "UHVIO DC Electrical Characteristics," on page 31: <ul style="list-style-type: none"> —Changed test condition "Iout = -1 mA" to "Iout = -0.8 mA" in the first row —Removed test condition "Iout= specified Ioh Drive" from the first row —Removed "0.8 x OVDD" from the Min column of the first row —Changed test condition "Iout = 1 mA" to "Iout = 0.8 mA" in the second row —Removed test condition "Iout= specified Iol Drive" from the second row —Removed "0.2 x OVDD" from the Max column of the second row —Removed rows 3–6

Table 117. i.MX53 Data Sheet Document Revision History (continued)

Rev. Number	Date	Substantive Change(s)
Rev. 4 (continued)	11/2011	<ul style="list-style-type: none"> • In Section 4.3.5, "LVDS I/O DC Parameters," added the sentence "The parameters in Table 17 are guaranteed per the operating ranges in Table 7, unless otherwise noted." before Table 17. • In Table 17, "LVDS DC Electrical Characteristics," on page 32, changed test condition "Rload=100Ω padP, -padN" to "Rload = 100Ω between padP and padN". • In Table 36, "NFC—Timing Characteristics," on page 49, corrected footnote number for Tdl. • In Table 52, "SD/eMMC4.3 Interface Timing Specification," on page 72, updated eSDHC output delay. • In Table 53, "eMMC4.4 Interface Timing Specification," on page 73, updated eSDHC output delay. • In Table 65, "TV Encoder Video Performance Specifications," on page 94, changed test condition "Fout = 9.28 MHz" for SFDR to "Fout = 8.3 MHz".
Rev. 3	06/2011	<ul style="list-style-type: none"> • In Table 7, "i.MX53 Operating Ranges," on page 18, updated operating ranges of VDDGP and VCC. • In Section 4.1.1, "Absolute Maximum Ratings," updated the caution note on page 16.
Rev. 2	05/2011	Initial release.

How To Reach Us

Home Page:

nxp.com

Web Support:

nxp.com/support

Limited warranty and liability — Information in this document is believed to be accurate and reliable. However, NXP Semiconductors does not give any representations or warranties, expressed or implied, as to the accuracy or completeness of such information and shall have no liability for the consequences of use of such information. NXP Semiconductors takes no responsibility for the content in this document if provided by an information source outside of NXP Semiconductors. In no event shall NXP Semiconductors be liable for any indirect, incidental, punitive, special or consequential damages (including - without limitation - lost profits, lost savings, business interruption, costs related to the removal or replacement of any products or rework charges) whether or not such damages are based on tort (including negligence), warranty, breach of contract or any other legal theory.

Notwithstanding any damages that customer might incur for any reason whatsoever, NXP Semiconductors' aggregate and cumulative liability towards customer for the products described herein shall be limited in accordance with the Terms and conditions of commercial sale of NXP Semiconductors.

Right to make changes - NXP Semiconductors reserves the right to make changes to information published in this document, including without limitation specifications and product descriptions, at any time and without notice. This document supersedes and replaces all information supplied prior to the publication hereof.

Security — Customer understands that all NXP products may be subject to unidentified or documented vulnerabilities. Customer is responsible for the design and operation of its applications and products throughout their lifecycles to reduce the effect of these vulnerabilities on customer's applications and products. Customer's responsibility also extends to other open and/or proprietary technologies supported by NXP products for use in customer's applications. NXP accepts no liability for any vulnerability. Customer should regularly check security updates from NXP and follow up appropriately.

Customer shall select products with security features that best meet rules, regulations, and standards of the intended application and make the ultimate design decisions regarding its products and is solely responsible for compliance with all legal, regulatory, and security related requirements concerning its products, regardless of any information or support that may be provided by NXP. NXP has a Product Security Incident Response Team (PSIRT) (reachable at PSIRT@nxp.com) that manages the investigation, reporting, and solution release to security vulnerabilities of NXP products.

Suitability for use — NXP Semiconductors products are not designed, authorized or warranted to be suitable for use in life support, life-critical or safety-critical systems or equipment, nor in applications where failure or malfunction of an NXP Semiconductors product can reasonably be expected to result in personal injury, death or severe property or environmental damage. NXP Semiconductors and its suppliers accept no liability for inclusion and/or use of NXP Semiconductors products in such equipment or applications and therefore such inclusion and/or use is at the customer's own risk.

Applications — Applications that are described herein for any of these products are for illustrative purposes only. NXP Semiconductors makes no representation or warranty that such applications will be suitable for the specified use without further testing or modification.

Customers are responsible for the design and operation of their applications and products using NXP Semiconductors products, and NXP Semiconductors accepts no liability for any assistance with applications or customer product design. It is customer's sole responsibility to determine whether the NXP Semiconductors product is suitable and fit for the customer's applications and products planned, as well as for the planned application and use of customer's third party customer(s). Customers should provide appropriate design and operating safeguards to minimize the risks associated with their applications and products.

NXP Semiconductors does not accept any liability related to any default, damage, costs or problem which is based on any weakness or default in the customer's applications or products, or the application or use by customer's third party customer(s). Customer is responsible for doing all necessary testing for the customer's applications and products using NXP Semiconductors products in order to avoid a default of the applications and the products or of the application or use by customer's third party customer(s). NXP does not accept any liability in this respect.

Limiting values — Stress above one or more limiting values (as defined in the Absolute Maximum Ratings System of IEC 60134) will cause permanent damage to the device. Limiting values are stress ratings only and (proper) operation

Table continues on the next page...

of the device at these or any other conditions above those given in the Recommended operating conditions section (if present) or the Characteristics sections of this document is not warranted. Constant or repeated exposure to limiting values will permanently and irreversibly affect the quality and reliability of the device.

Terms and conditions of commercial sale — NXP Semiconductors products are sold subject to the general terms and conditions of commercial sale, as published at <http://www.nxp.com/profile/terms>, unless otherwise agreed in a valid written individual agreement. In case an individual agreement is concluded only the terms and conditions of the respective agreement shall apply. NXP Semiconductors hereby expressly objects to applying the customer's general terms and conditions with regard to the purchase of NXP Semiconductors products by customer.

No offer to sell or license — Nothing in this document may be interpreted or construed as an offer to sell products that is open for acceptance or the grant, conveyance or implication of any license under any copyrights, patents or other industrial or intellectual property rights.

Bare die — All die are tested on compliance with their related technical specifications as stated in this data sheet up to the point of wafer sawing and are handled in accordance with the NXP Semiconductors storage and transportation conditions. If there are data sheet limits not guaranteed, these will be separately indicated in the data sheet. There are no post-packing tests performed on individual die or wafers.

NXP Semiconductors has no control of third party procedures in the sawing, handling, packing or assembly of the die. Accordingly, NXP Semiconductors assumes no liability for device functionality or performance of the die or systems after third party sawing, handling, packing or assembly of the die. It is the responsibility of the customer to test and qualify their application in which the die is used. All die sales are conditioned upon and subject to the customer entering into a written die sale agreement with NXP Semiconductors through its legal department.

NXP, the NXP logo, NXP SECURE CONNECTIONS FOR A SMARTER WORLD, COOLFLUX, EMBRACE, GREENCHIP, HITAG, ICODE, JCOP, LIFE, VIBES, MIFARE, MIFARE CLASSIC, MIFARE DESFire, MIFARE PLUS, MIFARE FLEX, MANTIS, MIFARE ULTRALIGHT, MIFARE4MOBILE, MIGLO, NTAG, ROADLINK, SMARTLX, SMARTMX, STARPLUG, TOPFET, TRENCHMOS, UCODE, Freescale, the Freescale logo, AltiVec, CodeWarrior, ColdFire, ColdFire+, the Energy Efficient Solutions logo, Kinetis, Layerscape, MagniV, mobileGT, PEG, PowerQUICC, Processor Expert, QorIQ, QorIQ Qonverge, SafeAssure, the SafeAssure logo, StarCore, Symphony, VortiQa, Vybrid, Airfast, BeeKit, BeeStack, CoreNet, Flexis, MXC, Platform in a Package, QUICC Engine, Tower, TurboLink, EdgeScale, EdgeLock, eIQ, and Immersive3D are trademarks of NXP B.V. All other product or service names are the property of their respective owners. AMBA, Arm, Arm7, Arm7TDMI, Arm9, Arm11, Artisan, big.LITTLE, Cordio, CoreLink, CoreSight, Cortex, DesignStart, DynamIQ, Jazelle, Keil, Mali, Mbed, Mbed Enabled, NEON, POP, RealView, SecurCore, Socrates, Thumb, TrustZone, ULINK, ULINK2, ULINK-ME, ULINK-PLUS, ULINKpro, μ Vision, Versatile are trademarks or registered trademarks of Arm Limited (or its subsidiaries) in the US and/or elsewhere. The related technology may be protected by any or all of patents, copyrights, designs and trade secrets. All rights reserved. Oracle and Java are registered trademarks of Oracle and/or its affiliates. M, M Mobileye and other Mobileye trademarks or logos appearing herein are trademarks of Mobileye Vision Technologies Ltd. in the United States, the EU and/or other jurisdictions.

© NXP B.V. 2011-2021.

All rights reserved.

For more information, please visit: <http://www.nxp.com>

For sales office addresses, please send an email to: salesaddresses@nxp.com

Date of release: 02/2021

Document identifier: IMX53IEC