

REVISION RECORD				
REV	ECO	DESCRIPTION	DRFT	CHKD

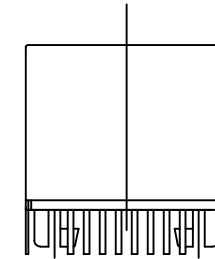

SECTION A-A

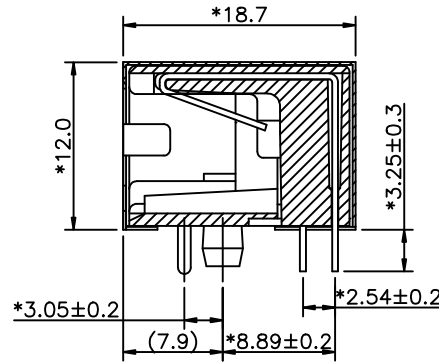
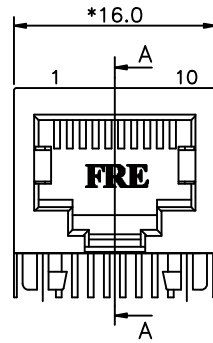
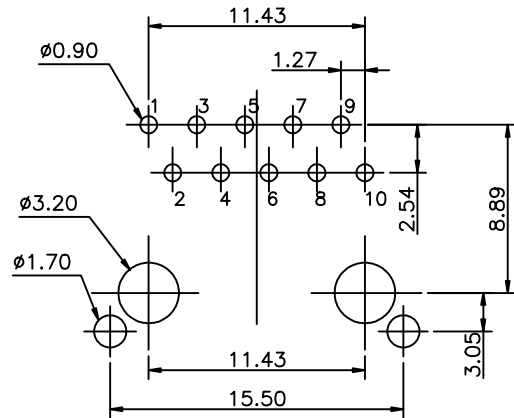
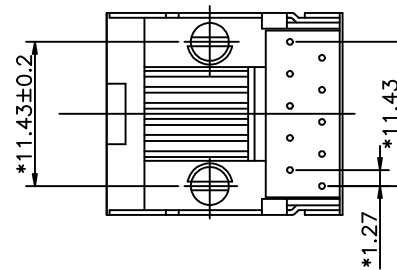

PC Board Layout Component Side Shown

NOTES:

ELECTRICAL:

- VOLTAGE RATING : 125 VAC RMS.
- CURRENT RATING : 1.5 AMP.
- CONTACT RESISTANCE : 40 MILLIOHMS MAX.
- INSULATION RESISTANCE: 1000 MEGOHMS MIN @ 500 VDC.
- DIELECTRIC STRENGTH : 1000 VAC RMS 60Hz, 1MIN.

MECHANICAL:

- HOUSING & INSERT MATERIAL : PBT+30%G.F UL94V-0.
- CONTACT MATERIAL : PHOSPHOR BRONZE Ø0.46mm.
- CONTACT PLATING : GOLD PLATING OVER NICKEL.
- SHIELD MATERIAL : 0.25mm THICKNESS BRASS C2680 H.
- SHIELD PLATING : SELECTIVE PLATED TIN_LEAD OVER NICKEL OR PLATED NICKEL
- OPERATING LIFE : 750 CYCLES MIN.
- PCB RETENTION PRE-SOLDER : 1 LB MIN.
- PCB RETENTION POST-SOLDER: 10 LBS MIN.

ENVIRONMENTAL:

- STORAGE : -40°C TO +85°C.
- OPERATION: -40°C TO +85°C.
- WAVE SOLDERING TEMPERATURE: 230~250°C (3~5 SECONDS)

MATES WITH MODULAR PLUG CONFORMING TO FCC PART 68, SUBPART F.

CUL FILE NO. E163191

LEAD FREE PART NUMBER: E560X-4E006X-L

NO. OF CONTACT	1- 3u"	2- 6u"	F-GOLD FLASH
8- 8 CONTACTS	3-15u"	4-30u"	
1-10 CONTACTS	5-50u"	6-Pd 20u"	

DETACHED LISTS	MM (INCH)	DFTO QSJ	DATE 7/1/05'	FULL RISE ELECTRONIC CO., LTD	
	TOLERANCES EXCEPT AS NOTED	CHKD	DATE		
	MM	MFO	DATE	TITLE 11.5 SIDE ENTRY PCB JACK 10P	
	.0 ±0.20	APPVL XLF	DATE 07/04/05'		
.00 ±0.15	MATERIAL :	DRAWING NO. GE563004-LC		SIZE A3	REV 0
.000 ±0.075	ANGLES ±	QTY :	/PART NO. SEE NOTE		
THIRD ANGLE PROJECTION	FINISH :	SCALE : 2.5:1	DO NOT SCALE DRAWING		SHEET X OF Y