



STEVAL-SPDC01V1 STEVAL-SPDC01V2

10 A DC-DC high density PoL convert module demonstration boards based on the SPDC12L00010

Data brief

Features

- 10 A max output current
- Input voltage range from 1.8 V to 14 V
- Supply voltage range from 4.5 V to 14 V
- Fixed or adjustable output voltage down to 0.6 V
- Fixed frequency voltage mode control
- Adjustable switching frequency
- Soft-start and inhibit
- Selectable UVLO threshold (5 V or 12 V bus)
- Master/slave synchronization with 180° phase shift
- Pre-bias startup capability
- Selectable source/sink or source only capability after soft-start
- Power Good output with programmable delay
- Overvoltage protection with selectable latched/not-latched mode
- Thermal shutdown
- Operating temperature range from -40 °C to 85 °C
- Pb-Free and RoHS compliant

Description

The boards are based on a single module SPDC12L00010, high density 10 A DC-DC converter, that implements a complete step-down power supply.

A single LGA package includes ST switching controller, power FETs, inductor and all the support components and it is able to operate over a wide input voltage range of 1.8 V to 14 V, supporting an output range of 0.6 V to 5 V. High level of integration and synchronous rectification allows this module to deliver up to 10 A continuous current at up to 93% efficiency,

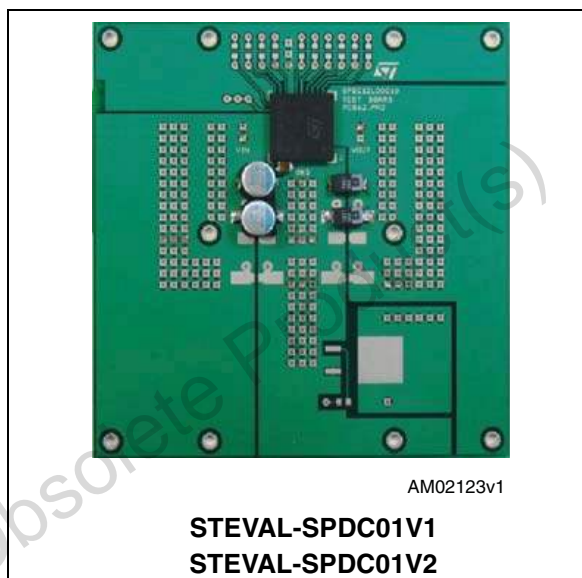

without external heat sink or airflow. The device is a complete standalone surface mount power supply, that can be handled and assembled like a standard integrated circuit. Moreover its low profile design permits to be soldered onto the back side of a printed circuit board, freeing up valuable board space.

The SPDC12L00010 is self-protected against overvoltage and short-circuit conditions.

A built-in adjustable soft-start and inhibit guarantee correct functionality whatever the load is.

Pre-bias start up capability is in place as well Power Good output with programmable delay to avoid false signals.

The device is packaged in a thermally enhanced, compact (15 x 15 mm) and low profile (3 mm) overmolded land grid array (LGA) package, suitable for automated assembly by standard surface-mount equipment.

The demonstration boards are an essential tool for testing the module and it is Pb-Free and RoHS compliant.

1 Circuit schematic

Figure 1. Schematic diagram

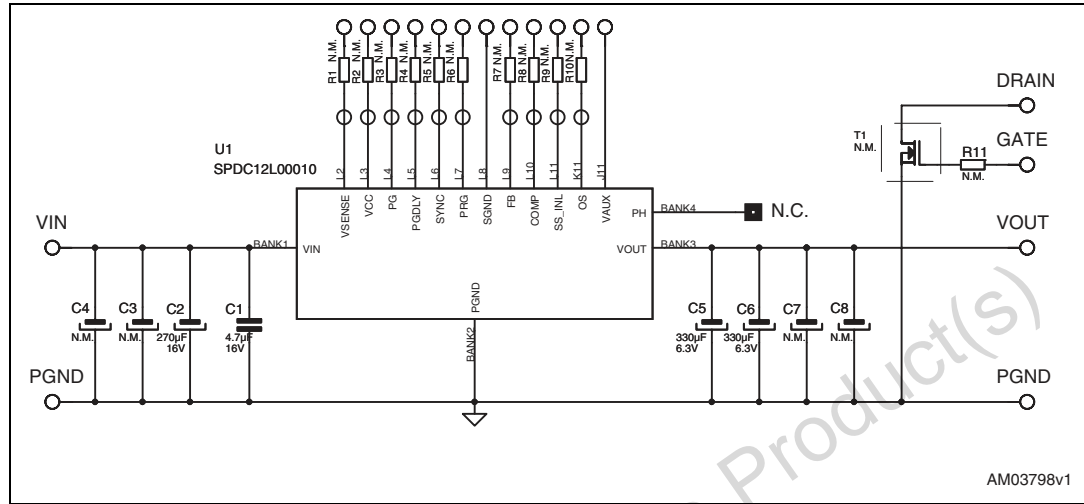

AM03798v1

2 Revision history

Table 1. Document revision history

Date	Revision	Changes
21-Apr-2009	1	Initial release.
19-Oct-2009	2	Inserted new part number

Obsolete Product(s) - Obsolete Product(s)

Please Read Carefully:

Information in this document is provided solely in connection with ST products. STMicroelectronics NV and its subsidiaries ("ST") reserve the right to make changes, corrections, modifications or improvements, to this document, and the products and services described herein at any time, without notice.

All ST products are sold pursuant to ST's terms and conditions of sale.

Purchasers are solely responsible for the choice, selection and use of the ST products and services described herein, and ST assumes no liability whatsoever relating to the choice, selection or use of the ST products and services described herein.

No license, express or implied, by estoppel or otherwise, to any intellectual property rights is granted under this document. If any part of this document refers to any third party products or services it shall not be deemed a license grant by ST for the use of such third party products or services, or any intellectual property contained therein or considered as a warranty covering the use in any manner whatsoever of such third party products or services or any intellectual property contained therein.

UNLESS OTHERWISE SET FORTH IN ST'S TERMS AND CONDITIONS OF SALE ST DISCLAIMS ANY EXPRESS OR IMPLIED WARRANTY WITH RESPECT TO THE USE AND/OR SALE OF ST PRODUCTS INCLUDING WITHOUT LIMITATION IMPLIED WARRANTIES OF MERCHANTABILITY, FITNESS FOR A PARTICULAR PURPOSE (AND THEIR EQUIVALENTS UNDER THE LAWS OF ANY JURISDICTION), OR INFRINGEMENT OF ANY PATENT, COPYRIGHT OR OTHER INTELLECTUAL PROPERTY RIGHT.

UNLESS EXPRESSLY APPROVED IN WRITING BY AN AUTHORIZED ST REPRESENTATIVE, ST PRODUCTS ARE NOT RECOMMENDED, AUTHORIZED OR WARRANTED FOR USE IN MILITARY, AIR CRAFT, SPACE, LIFE SAVING, OR LIFE SUSTAINING APPLICATIONS, NOR IN PRODUCTS OR SYSTEMS WHERE FAILURE OR MALFUNCTION MAY RESULT IN PERSONAL INJURY, DEATH, OR SEVERE PROPERTY OR ENVIRONMENTAL DAMAGE. ST PRODUCTS WHICH ARE NOT SPECIFIED AS "AUTOMOTIVE GRADE" MAY ONLY BE USED IN AUTOMOTIVE APPLICATIONS AT USER'S OWN RISK.

Resale of ST products with provisions different from the statements and/or technical features set forth in this document shall immediately void any warranty granted by ST for the ST product or service described herein and shall not create or extend in any manner whatsoever, any liability of ST.

ST and the ST logo are trademarks or registered trademarks of ST in various countries.

Information in this document supersedes and replaces all information previously supplied.

The ST logo is a registered trademark of STMicroelectronics. All other names are the property of their respective owners.

© 2009 STMicroelectronics - All rights reserved

STMicroelectronics group of companies

Australia - Belgium - Brazil - Canada - China - Czech Republic - Finland - France - Germany - Hong Kong - India - Israel - Italy - Japan - Malaysia - Malta - Morocco - Philippines - Singapore - Spain - Sweden - Switzerland - United Kingdom - United States of America

www.st.com