

## 5 Adjustments

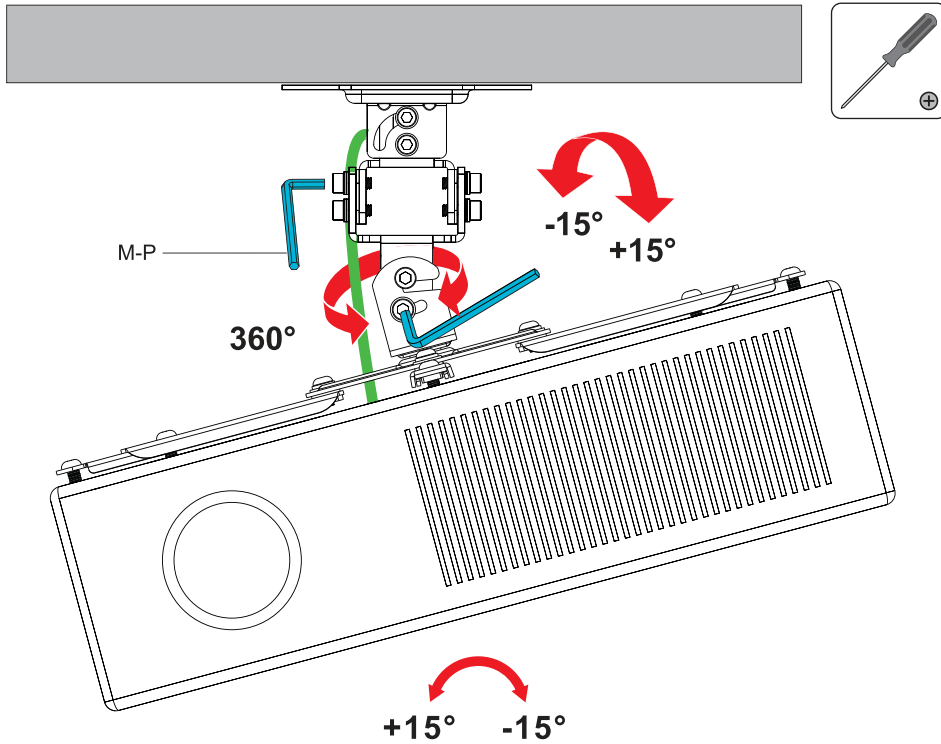

### IMPORTANT!

Do not loosen screws all the way when making adjustments, this will disconnect the parts and may cause injury or property damage.

Your projector ceiling mount is now installed. To make adjustments, loosen up the screws slightly with the alley key (M-P). When you are satisfied with the adjustments, tighten up the screws again.

## Maintenance

Please check that the projector mount is secure and safe to use at regular intervals. If you have any questions regarding any of the instructions or warnings, please contact your local distributor (OR) contact QualGear technical support via email at [support@qualgear.com](mailto:support@qualgear.com).

## PROJECTOR CEILING MOUNT

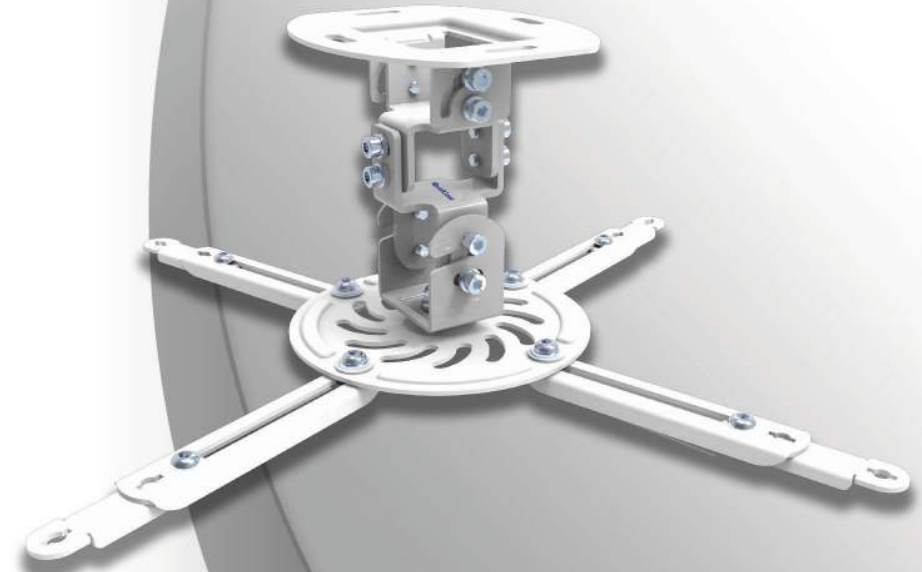

[www.qualgear.com](http://www.qualgear.com)



### CAUTION!

Do not exceed the maximum rated weight specified. Otherwise, serious injury or property damage may occur.



■ 1 Year Limited Warranty

■ Version August 2015

**NOTE** Please read the entire installation manual before you start installation and assembly.

## WARNING

- Do not begin to install your QualGear product until you have read and understood all the instructions and warnings contained in this installation manual. If you have any questions regarding the instructions, for US customers please contact QualGear customer support via email at support@qualgear.com. For all international customers, please contact your local distributor.
- This product should only be installed by someone of good mechanical aptitude, has experience with basic building construction, and fully understands these instructions.
- This product was designed to be installed and utilized only as specified in this manual. Improper installation of this product may cause damage or serious injury. QualGear is not liable for the improper use or installation of its products.
- Make sure that the supporting surface will safely support the combined load of the equipment and all attached hardware and components.
- Always use an assistant or mechanical lifting equipment to safely lift and position the equipment.
- Tighten screws firmly, but do not over tighten. Over tightening can damage the items, greatly reducing their holding power.
- ALL QUALGEAR products are intended for indoor use only and any outdoor use voids the limited warranty.
- ALL QUALGEAR products are designed and tested for residential use only and any commercial use voids the limited warranty. For warranty information, please visit <http://www.qualgear.com/warranty.php>.
- If mounting to wooden studs, make sure that mounting screws are anchored into the center of the studs. Use of an edge-to-edge stud finder is highly recommended.
- Never exceed the maximum rated weight specified in this manual.
- All bolts and screws must be used at the designated points in the installation instructions to prevent property damage and/or personal injury.
- DO NOT install near air conditioner vents or where there is excessive dust or smoke.
- When drilling holes in the ceiling, it is very important to take care of electrical cables, water, or gas pipes in the ceiling.

This product was designed to be installed on the following ceiling construction only:

### CEILING CONSTRUCTION

Wooden Stud  
Wooden Beam  
Solid Concrete  
Brick  
Other

### HARDWARE REQUIRED

Included  
Included  
Included  
Included  
Contact Qualified Professional

## Parts Checklist

**IMPORTANT:** Before starting installation, please check that all parts shown in this checklist are included. If any parts are missing or damaged, contact your local distributor or support@qualgear.com for replacement parts and do not start assembly and installation until you receive all the parts.

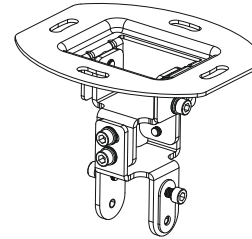

Ceiling Plate with Connector  
A (x1)

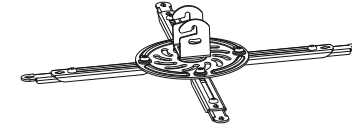

Projector Mounting Bracket  
B (x1)



Marking Template  
C (x1)

## Hardware Package



M3x20 (x4)  
M-A



M4x25 (x4)  
M-B



M5x25 (x4)  
M-C



M6x25 (x4)  
M-D



D3 Washer (x4)  
M-E



D4 Washer (x4)  
M-F



D5 Washer (x4)  
M-G



D6 Washer (x4)  
M-H



1mm Spacer (x4)  
M-I



2mm Spacer (x4)  
M-J



3mm Spacer (x4)  
M-K



5mm Spacer (x4)  
M-L



M5x12 (x2)  
M-M



D5 Ø5xØ10 (x2)  
Washer  
M-N



D5 (x2)  
Plastic Washer  
M-O



4mm Allen Key (x1)  
M-P



3mm Allen Key (x1)  
M-Q



ST6.3x65mm  
Lag Bolt (x4)  
W-A



10x60mm  
Concrete Anchor (x4)  
W-B



D6 Washer (x4)  
W-C

# 1 Cable Management

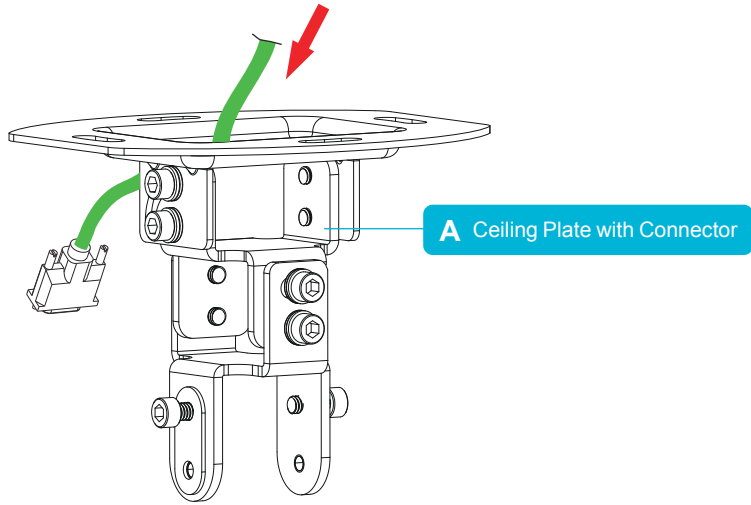

Feed the projector cable(s) through the top of the Ceiling Plate.

OR

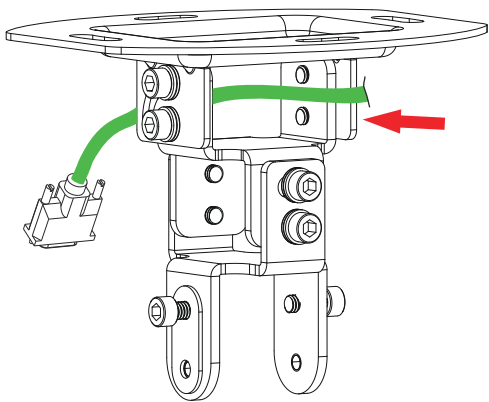

Feed the projector cable(s) through the side of the Ceiling Plate.

# 2a Mounting to a Wooden Ceiling



**NOTE** For concrete ceiling mounting, follow Step 2b.

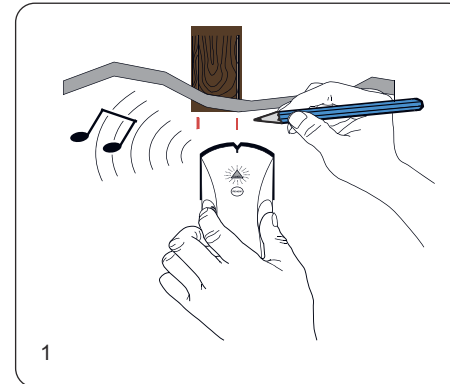

Using an edge-to-edge stud finder, find the edges of the stud.

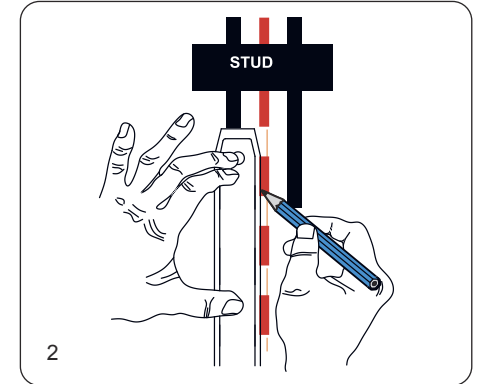

Using a straight edge, mark the centerline of the stud.

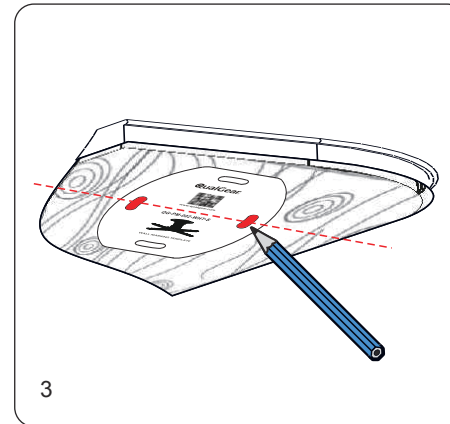

Using the marking template provided, mark two holes for drilling on the centerline of the stud.

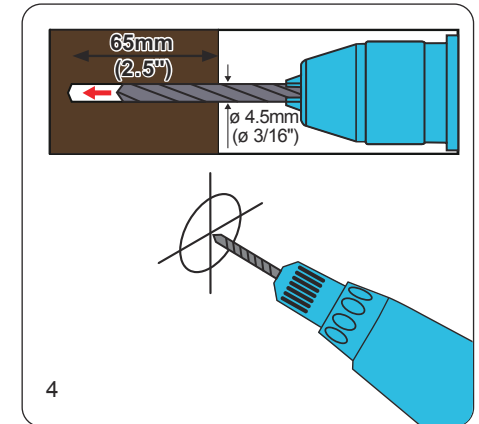

Using a power drill and 3/16" drill bit, drill pilot holes of 3/16" (4.5 mm) diameter and at least 2.5" (65 mm) depth.

**TIP** Depending on the direction of the studs, choose the mounting holes accordingly.



**NOTE** Do NOT use power drill and do NOT over tighten the lag bolts.

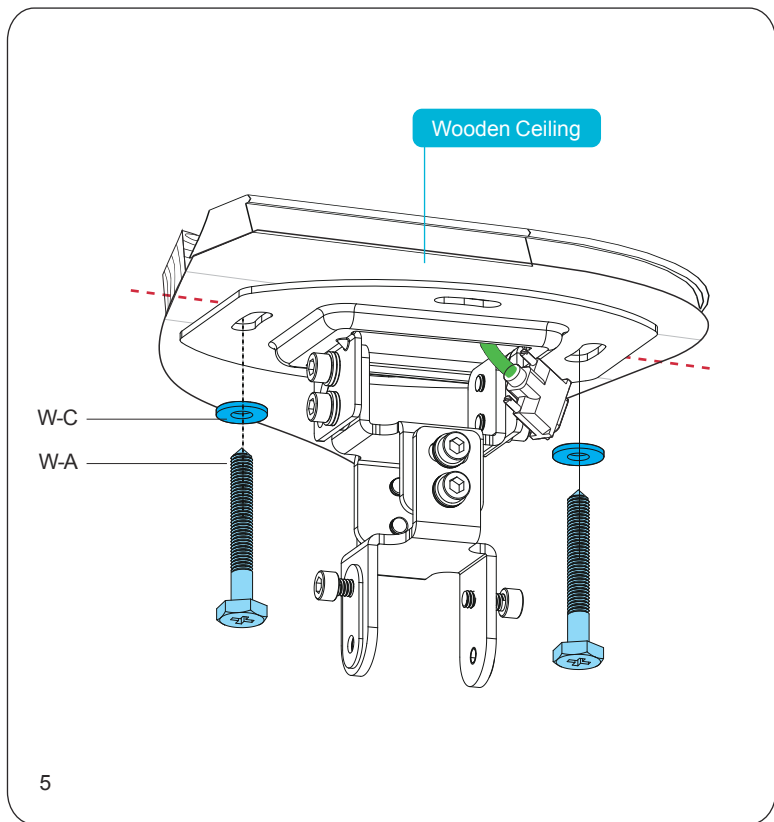

5 Using a socket wrench, mount the ceiling plate and fasten with the provided lag bolts (W-A) and D6 washers (W-C).

### **WARNING**

- Installers are responsible to provide hardware for other types of mounting situations.
- Installers must verify that the supporting surface will safely support the combined weight of the equipment and all attached hardware and components.

**SKIP TO STEP 3** 

## 2b Mounting to a Concrete Ceiling

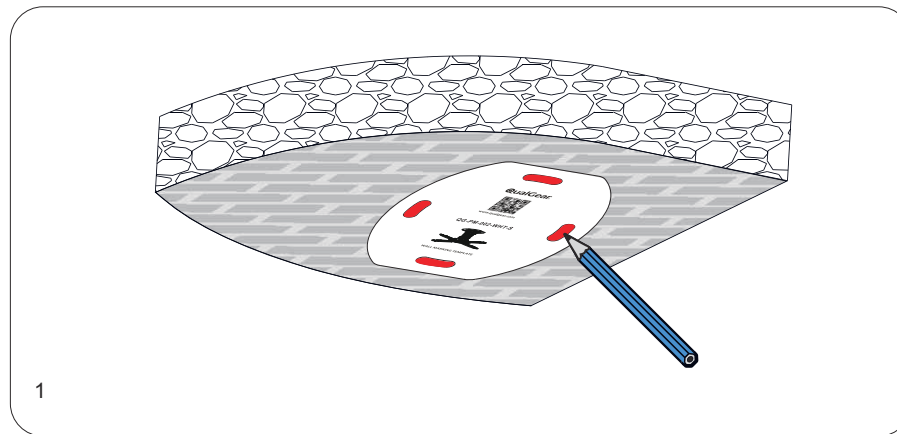

1 Hold the marking template provided against the ceiling where you want to install the projector, mark four holes for drilling.

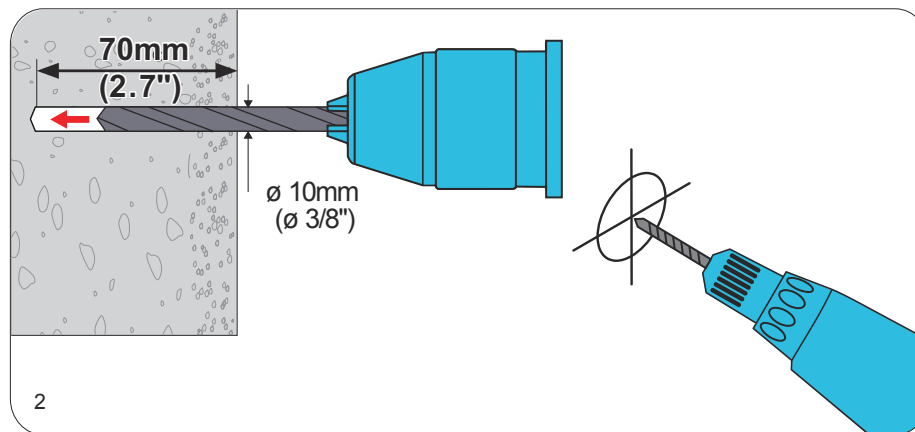

2 Using a power drill and a 3/8" masonry drill bit, drill mounting holes of 3/8" (10 mm) diameter and 2.7" (70 mm) depth at the marked locations in the previous step.

**NOTE** Do NOT use power drill and do NOT over tighten the lag bolts.

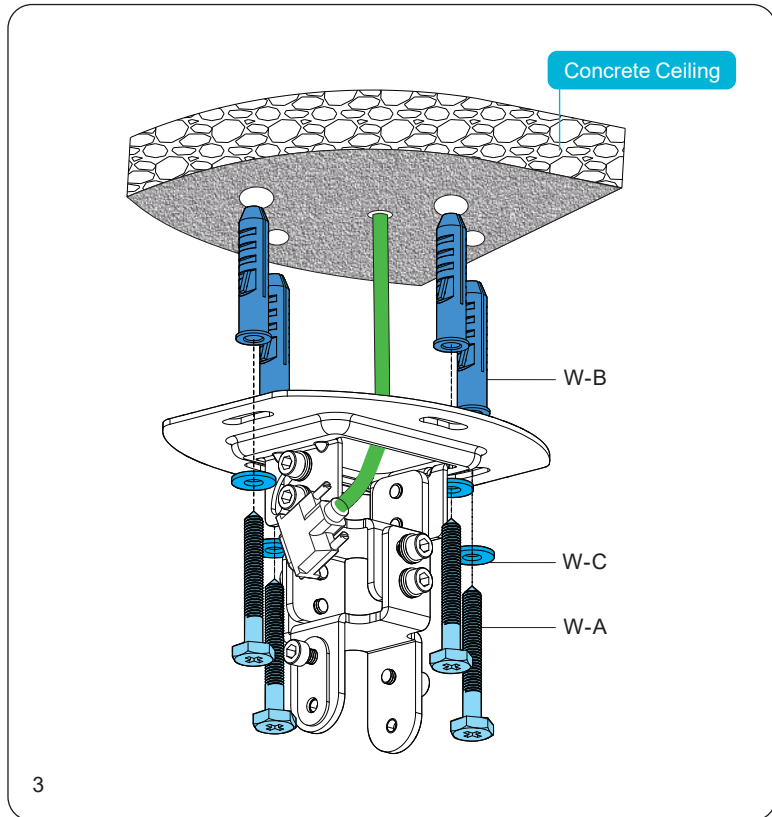

Place plastic anchors (W-B) in each hole. Tap each anchor flush with the ceiling using a hammer. Using a socket wrench, mount the ceiling plate and fasten with the provided lag bolts (W-A) and D6 washers (W-C).

## ⚠ WARNING

- Installers must verify that the supporting surface will safely support the combined weight of the equipment and all attached hardware and components.

### 3 Installing Projector Mounting Bracket to the Projector

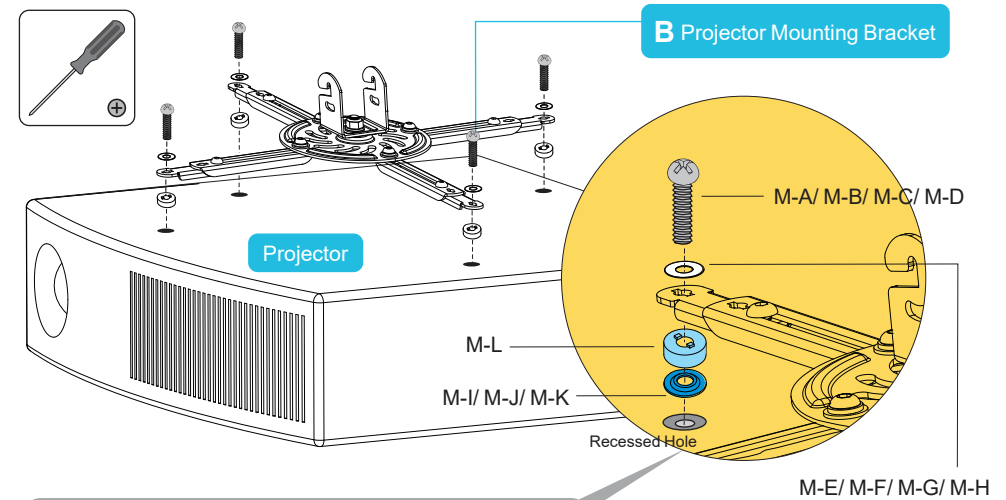

**NOTE** Choose the appropriate spacer (M-I/ M-J/ M-K) when mounting to recessed holes.

4 Long Extension Brackets  
+  
4 Short Extension Brackets

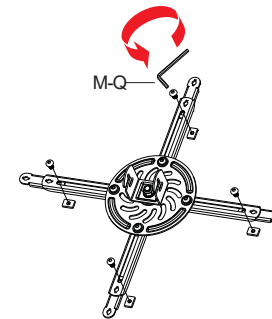

OR

4 Long Extension Brackets

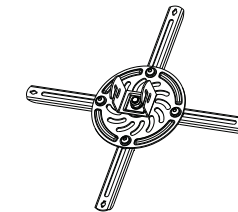

OR

2 Long Extension Brackets  
+  
2 Short Extension Brackets



**TIP** Depending on your projector, you may use one of the combinations above.

Align the holes of extension brackets over the mounting holes of the projector, select appropriate screws (M-A/ M-B/ M-C/ M-D) and washers (M-E/ M-F/ M-G/ M-H). Place bottom spacer (M-L) in between the brackets and the projector. **Optional:** for mounting to recessed holes only, choose appropriate spacer (M-I/ M-J/ M-K) in addition to the 5mm spacer (M-L).

#### 4 Installing the Projector Ceiling Mount Assembly

**!** **HEAVY!**  
Use an assistant for  
this step.

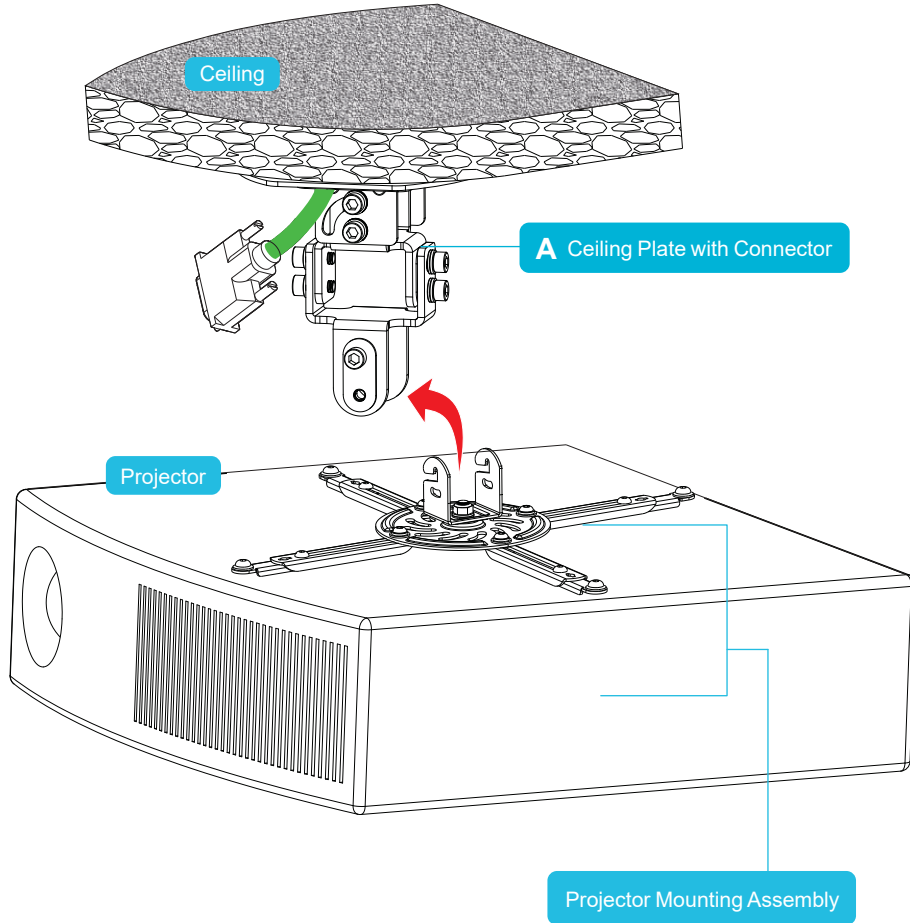

Align the Projector Mount Assembly to the Ceiling Plate with Connector, then using the Alley Key (M-P), attach them together with the provided Screws (M-M), Washers (M-N), and Plastic Washers (M-O).

**NOTE** This mount allows pitch and roll adjustments for a perfect viewing experience.

