

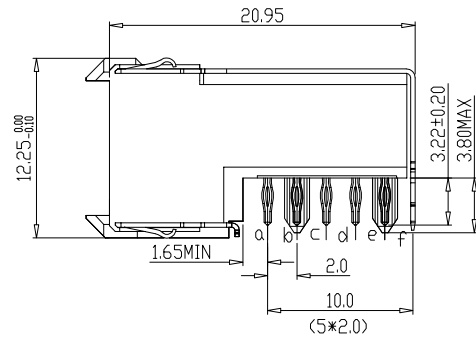

Tous droits strictement réservés. Reproduction ou communication à des tiers interdite sous quelque forme que ce soit sans autorisation écrite du propriétaire. Propriété de c FCI. Droits de reproduction FCI.

All rights strictly reserved. Reproduction or issue to third parties in any form whatever is not permitted without written authority from the proprietor. Property of FCI. Copyright FCI.

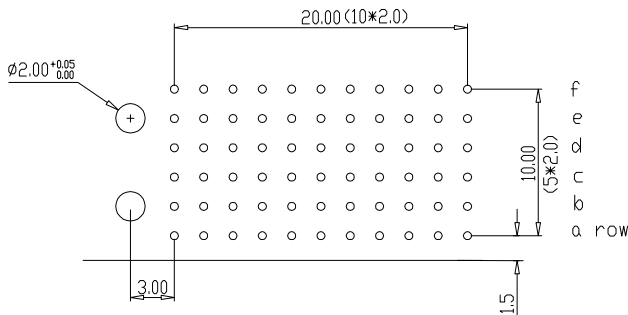
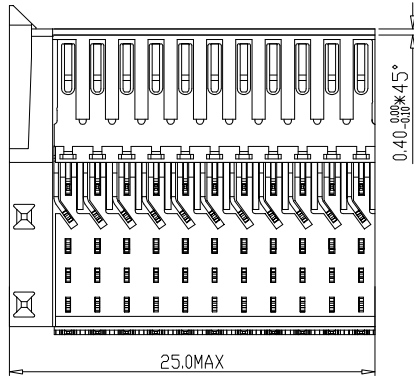
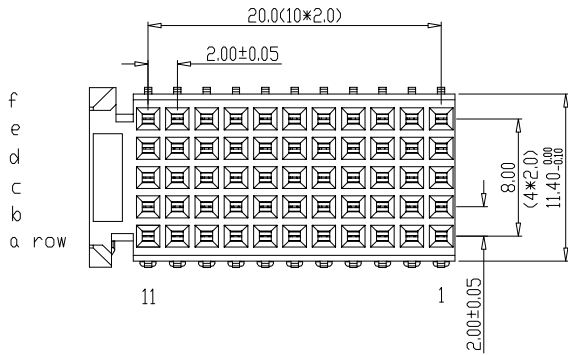

PERFORMANCE CHARACTERISTICS

- CURRENT RATING 1.5A AT 20°C (FULLY LOADED)
- 1 A AT 70°C (FULLY LOADED)
- RATED VOLTAGE : 500 V AC (CONT /CONT)
- OPERATING TEMPERATURE : -55°C TO 125°C
- CONTACT RESISTANCE 20 MΩ MAX
- INSERTION FORCE : 0.75N MAX/CONT
- EXTRACTION FORCE : 0.15N MIN/CONT
- INSULATION RESISTANCE : 10⁴ MΩ MIN

- NOTES 1: LEAD FREE INDICATOR (LF=LEAD FREE)
- PERFORMANCE LEVEL INDICATOR (REF DWG NO.BSC 201844.003)
- THIS PRODUCT IS CSA APPROVED. THIS PRODUCT IS UL RECOGNIZED.
 - FOR RECOMMENDED PTH DIMENSIONS REFER DRAWING : BS.A.201572.001
 - THIS PRODUCT (LF) MEETS EUROPEAN UNION DIRECTIVES AND OTHER COUNTRY REGULATIONS AS DESCRIBED IN GS-22-008

| rev | ecn no | dr | date |
|-----|------------------------|-------|----------|
| A | CONVERSION REVISION_05 | KN | 14-09-01 |
| B | DG05-0278 | Kason | 02-08-05 |
| C | DG07-0362 | Kason | 05-09-07 |
| D | DG10-0110 | NZ | 05-30-10 |
| - | - | - | - |
| - | - | - | - |

| Material | | Spec ref | |
|------------------|---------|----------------------------------|---|
| Mat code | | | tolerance 1DEC ± 0.2 1DEC 2DEC ± 0.1 2DEC ANGLES ± 1° HOEKEN |
| Heattreat | | | |
| Plating/Finish | | | |
| Dr | W.Panis | 07-04-92 | projection |
| Eng | | | size A4 |
| Chr | | | Scale 2.000 |
| Appr | | | REL Level |
| Product family | | MILLIPACS | |
| Model Name | | | |
| Model Revision | | | |
| title | | MPACS 5+2R RA RCP CONN TYPE C | Rev. D |
| Pro/E file | | catalog no | HM2R03PA5104---- |
| dwg no | | BSC201444020 | |
| CUSTOMER DRAWING | | sheet 1 of 1 | |