

# LPWA/WiFi Ceramic Chip Antenna



ACAR3005-C2WB



30.0 x 5.0 x 5.0 mm  
RoHS/RoHS II Compliant  
MSL = N/A

## Features

- LoRa/Sigfox at 868, 915 MHz
- NB/IoT coverage 824/960 MHz
- 2.4 GHz WiFi/Bluetooth/ISM
- Linear polarization
- SMD antenna

## Applications

- LoRa, Sigfox
- NB/IoT
- WiFi/Bluetooth/Zigbee applications
- Remote monitoring/smart meters
- Network devices
- Automation
- Asset tracking
- Smart city

## Electrical Characteristics

Item	Spec	
Working Frequency	824~960 MHz, 2400~2500 MHz	
Dimension	30.0 × 5.0 × 5.0 mm	
VSWR	<3.5	
Polarization	Linear	
Impedance	50 Ω	
Operating Temperature	-40~85°C	
Termination	Ag (Environmentally-Friendly Pb Free)	
Efficiency(%)	824~960 MHz	50
	2400~2500 MHz	40

\* Evaluation board size 40.0 x 120.0 mm<sup>2</sup>.

\* Actual electrical value will depend on customer ground plane size.

# LPWA/WiFi Ceramic Chip Antenna

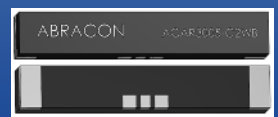

ACAR3005-C2WB



30.0 x 5.0 x 5.0 mm  
RoHS/RoHS II Compliant  
MSL = N/A

## S11 and VSWR Response Curve

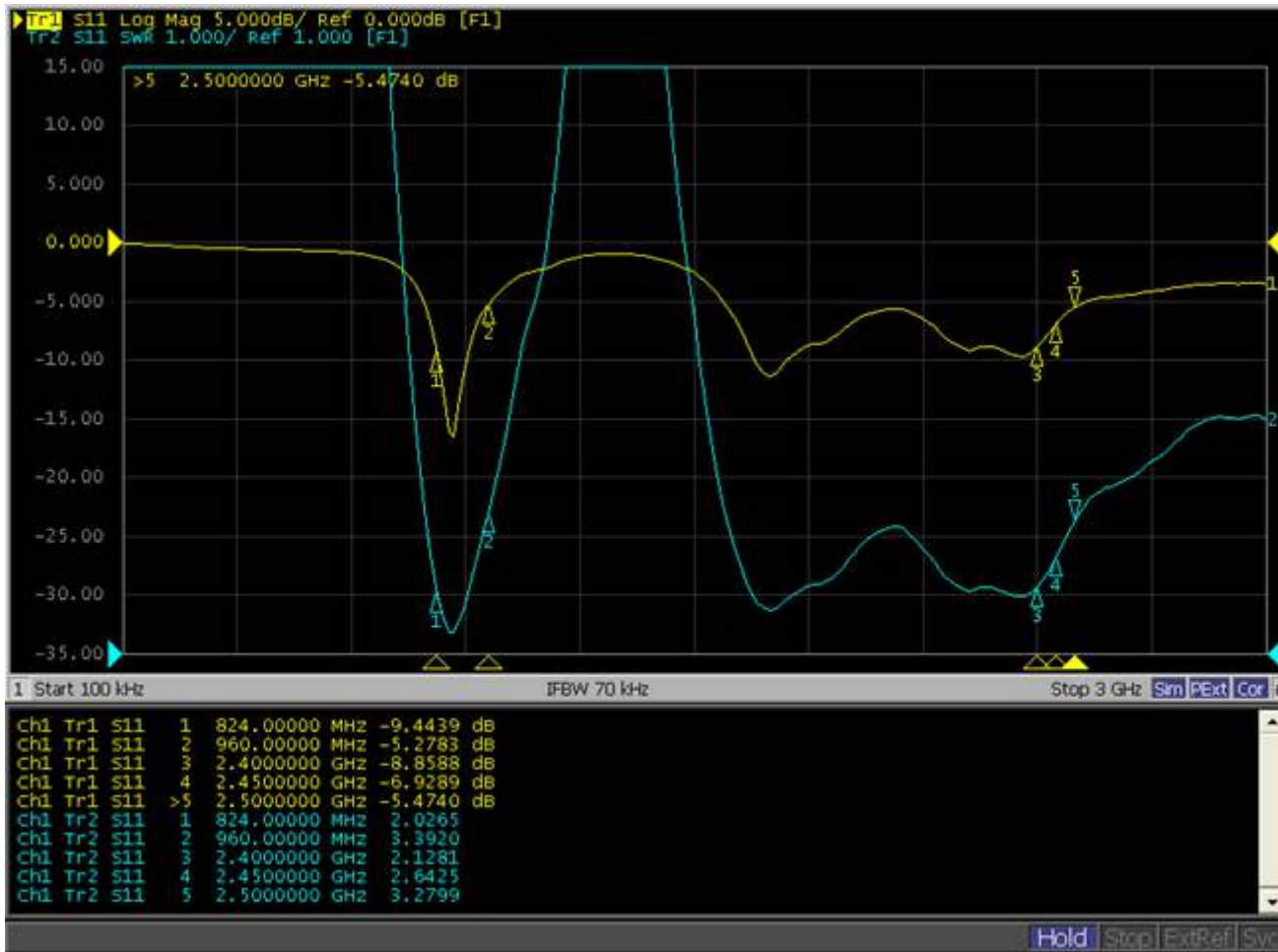

### Antenna Return Loss and VSWR

Frequency (MHz)	824MHz	960MHz	2400MHz	2450MHz	2500MHz
Return Loss (dB)	-9.44	-5.27	-8.85	-6.92	-5.47
VSWR	2.02	3.39	2.12	2.64	3.27

# LPWA/WiFi Ceramic Chip Antenna



ACAR3005-C2WB



30.0 x 5.0 x 5.0 mm  
RoHS/RoHS II Compliant  
MSL = N/A

## Gain and Efficiency

(Ground length: 107mm)

Antenna Peak Gain Parameter Summary					
Frequency	824	960	2400	2450	2500
Peak Gain(dBi)	0.84	0.08	2.61	2.20	1.18
Efficiency(%)	55.26	47.92	48.05	42.62	35.36

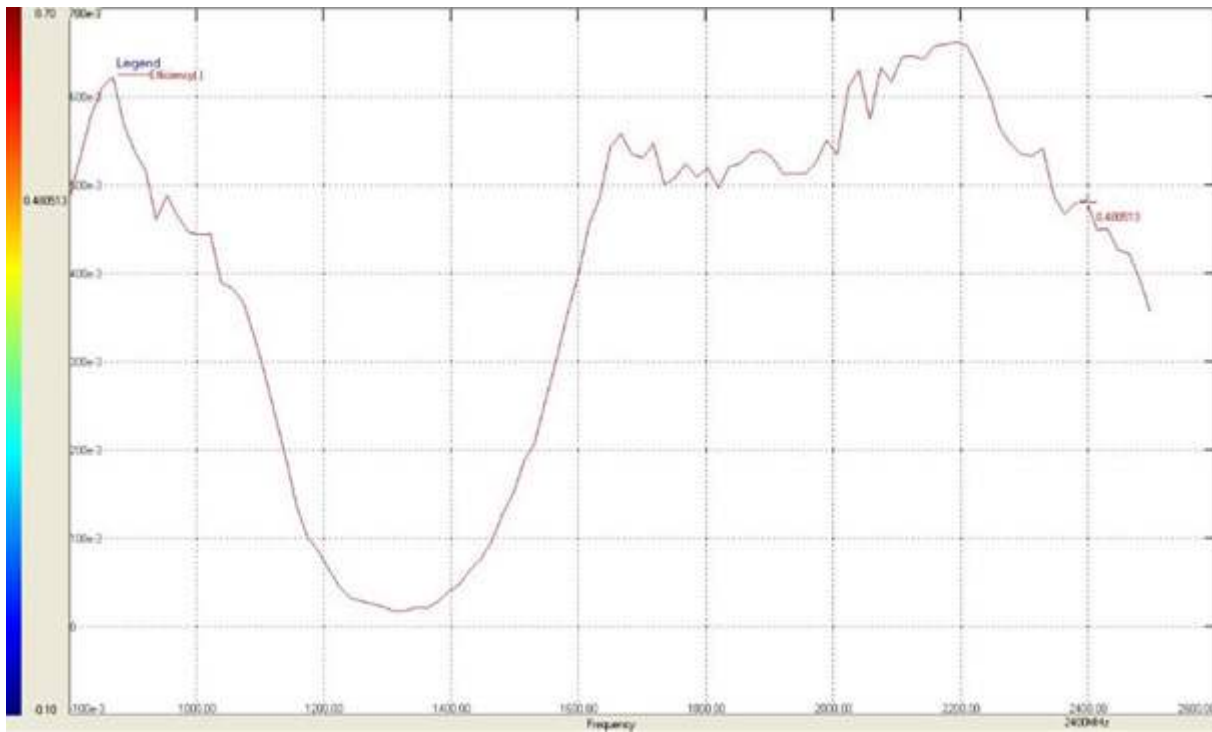

# LPWA/WiFi Ceramic Chip Antenna



ACAR3005-C2WB



30.0 x 5.0 x 5.0 mm  
RoHS/RoHS II Compliant  
MSL = N/A

## 3D Radiation Pattern

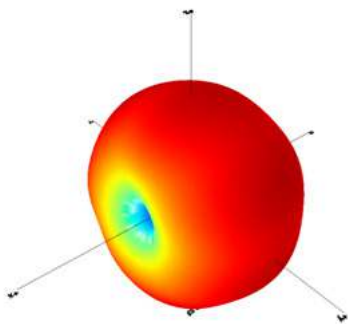
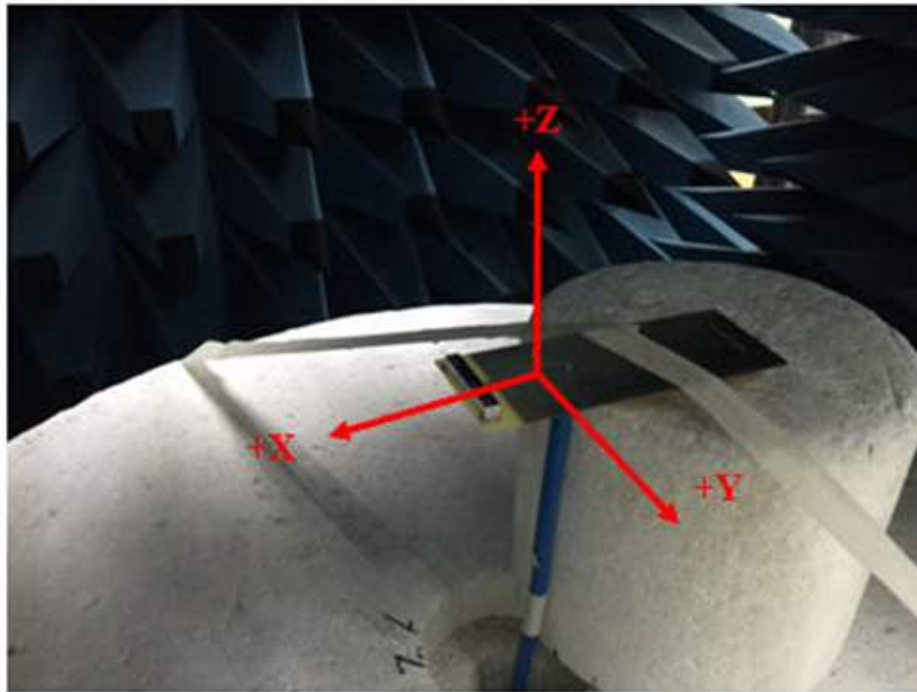

824MHz

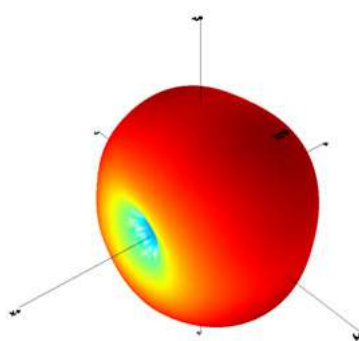

960MHz

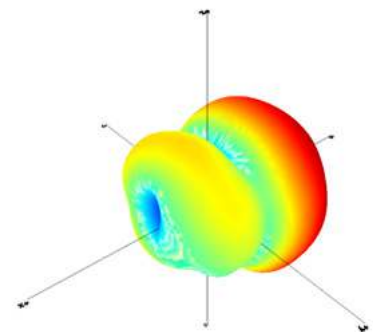

2450MHz

# LPWA/WiFi Ceramic Chip Antenna

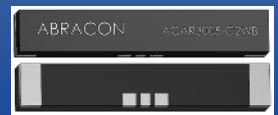

ACAR3005-C2WB



30.0 x 5.0 x 5.0 mm  
RoHS/RoHS II Compliant  
MSL = N/A

## Drawings

### Shape and Dimensions

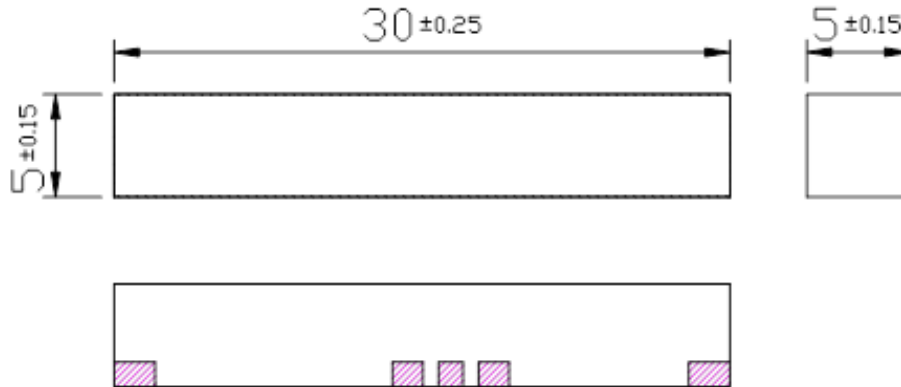

Unit: mm

### Layout Dimensions

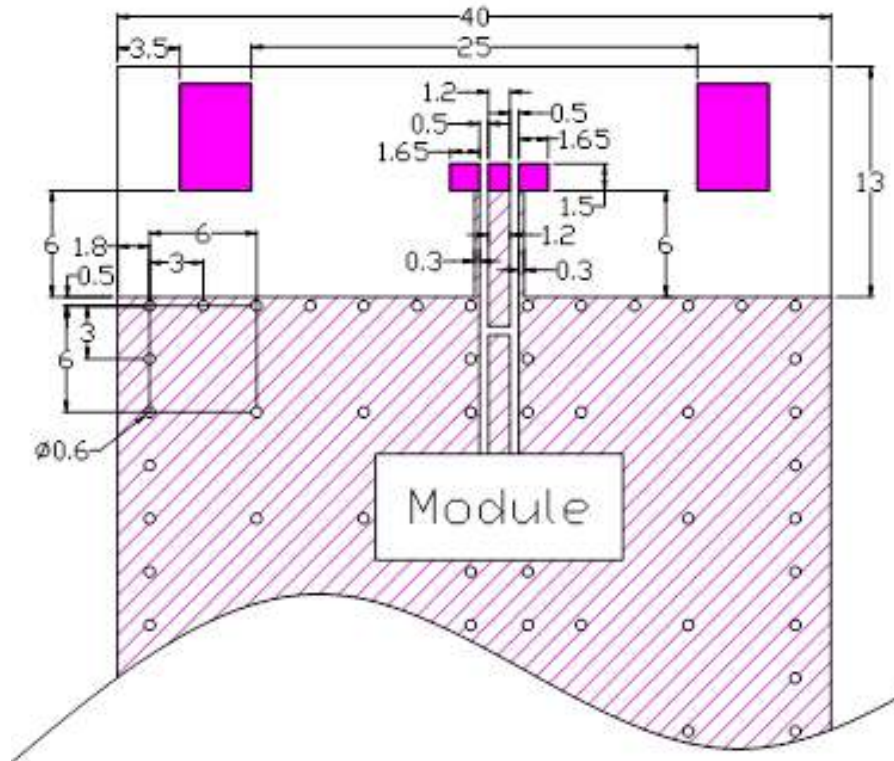

# LPWA/WiFi Ceramic Chip Antenna

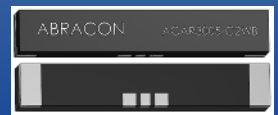

ACAR3005-C2WB



30.0 x 5.0 x 5.0 mm  
RoHS/RoHS II Compliant  
MSL = N/A

## Antenna Environment on Demo Board

### Matching Circuit

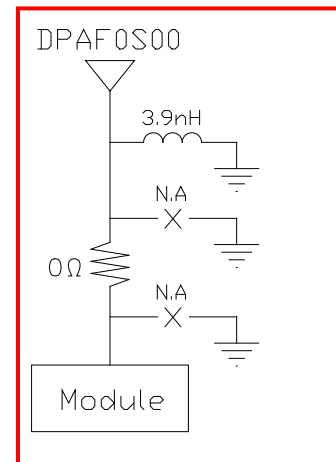
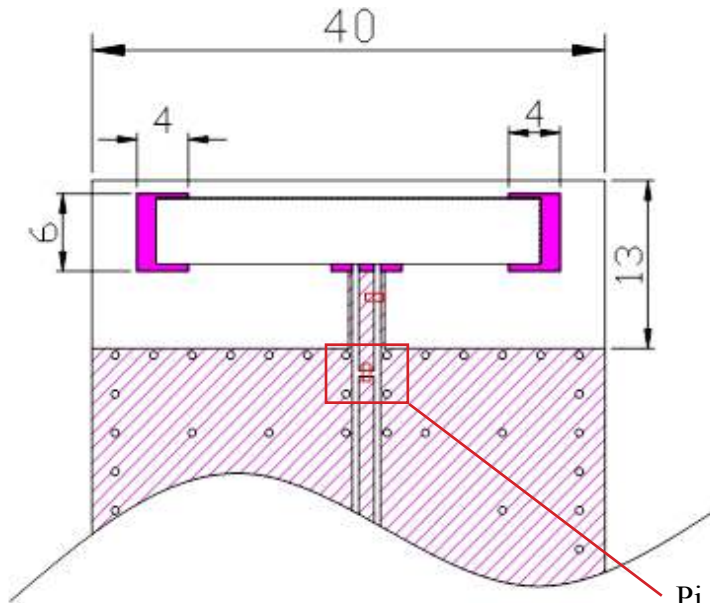

Pi Type Matching

Unit: mm

A pi type matching circuit is needed between antenna and module.

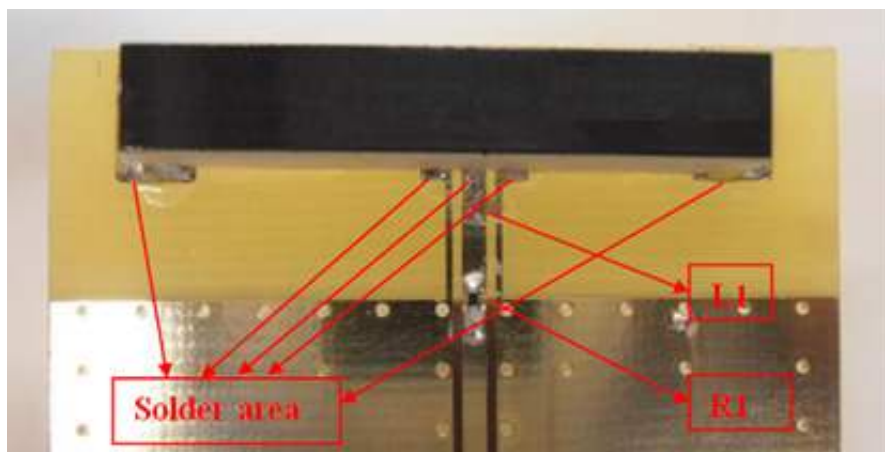

Circuit Symbol	Size	Description
L1	0402	3.9nH Inductor
R1	0402	0 Ω

# LPWA/WiFi Ceramic Chip Antenna



ACAR3005-C2WB



30.0 x 5.0 x 5.0 mm  
RoHS/RoHS II Compliant  
MSL = N/A

## Evaluation Board Dimensions

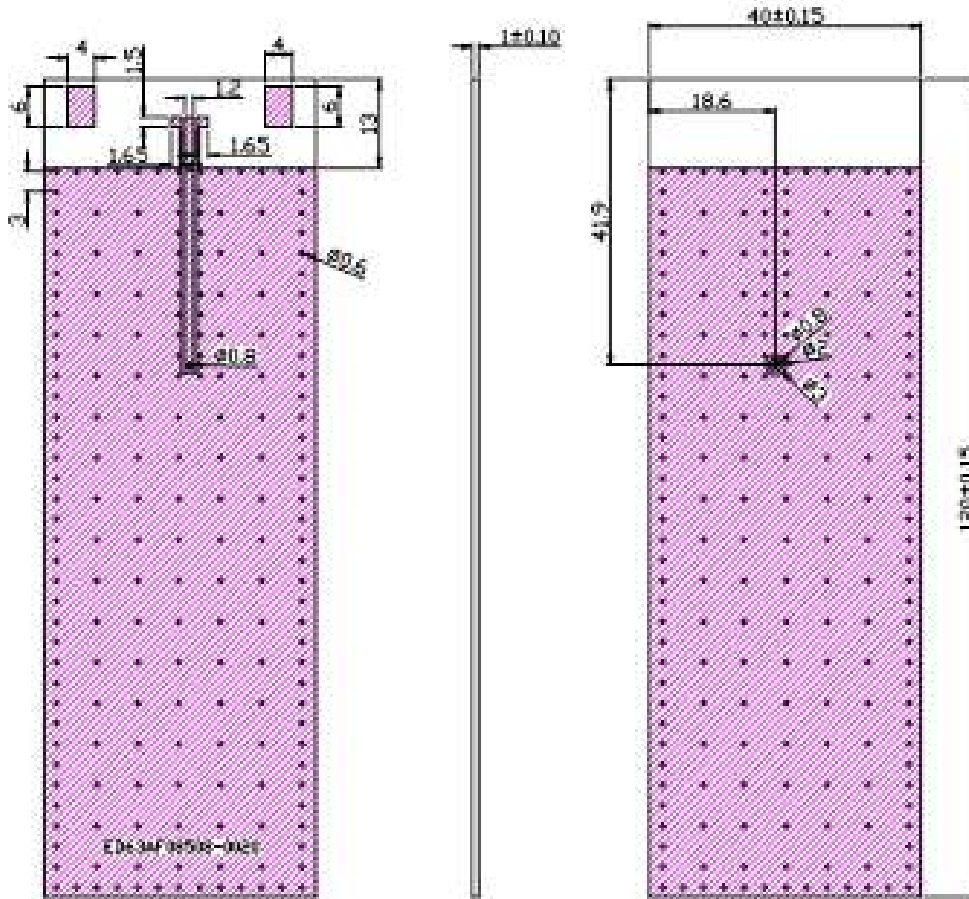

Unit: mm

# LPWA/WiFi Ceramic Chip Antenna



ACAR3005-C2WB



30.0 x 5.0 x 5.0 mm  
RoHS/RoHS II Compliant  
MSL = N/A

## Packaging

1. Blister tape to IEC 286-3, polyester
2. 450pcs/reel
3. 350 x 340 x 67mm (450pcs/Cartron-Inside)
4. 370 x 360 x 275mm (1350pcs/Cartron-Outside)
5. GW - 6.19KG

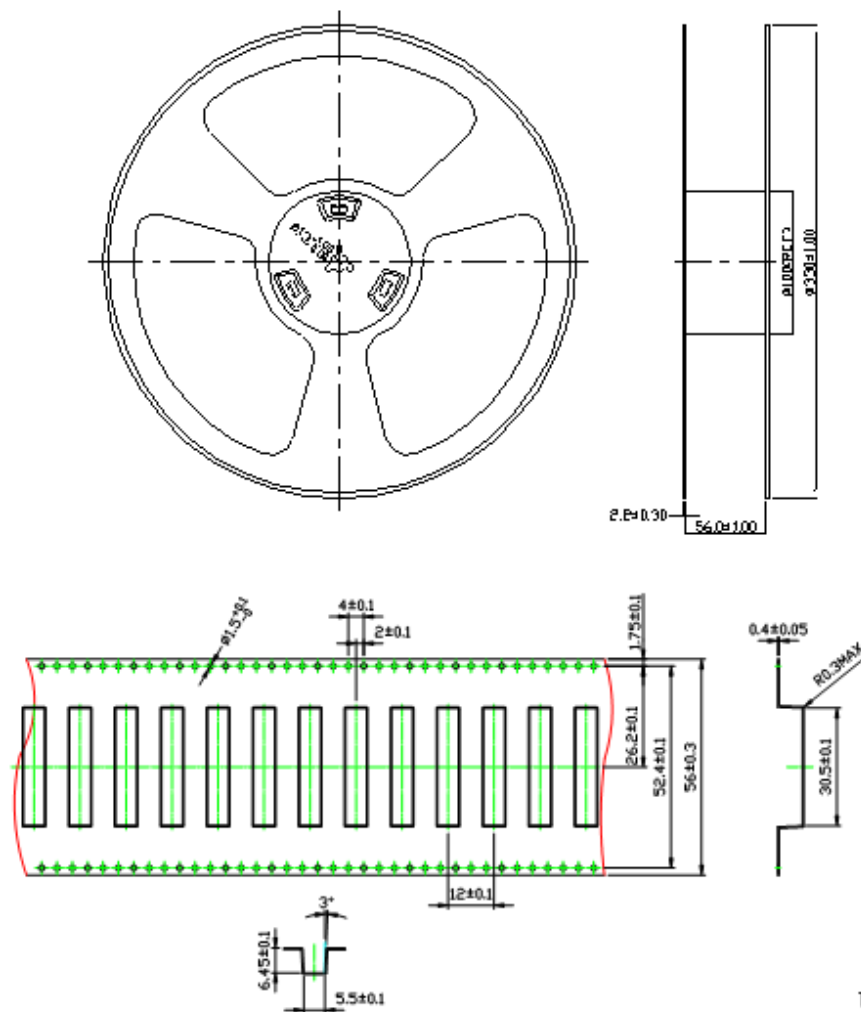

Unit: mm



5101 Hidden Creek Ln Spicewood TX 78669  
Phone: 512-371-6159 | Fax: 512-351-8858  
For terms and conditions of sales, please visit:  
[www.abracon.com](http://www.abracon.com)

REVISED: 11.09.2018

ABRACON IS  
ISO9001-2015  
CERTIFIED





ACAR3005-C2WB



30.0 x 5.0 x 5.0 mm  
RoHS/RoHS II Compliant  
MSL = N/A

## Transmission Line and Matching

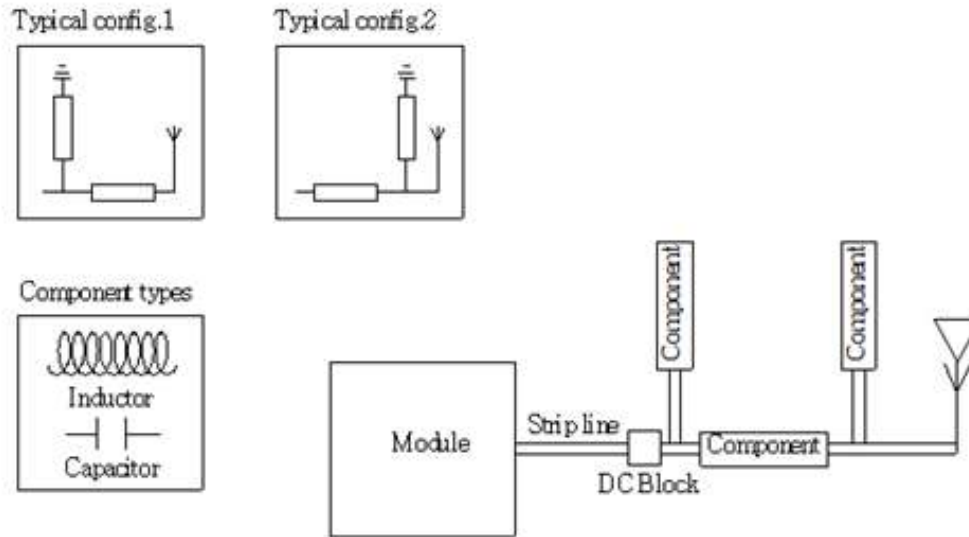

The matching network has to be individually designed using one, two, or three components.

## Recommended Reflow Soldering Profile

Abrakon products can be assembled following Pb-free assembly. According to the Standard IPC/JEDEC J-STD-020C, the temperature profile suggested is as follow:

Phase	Profile Features	Pb-Free Assembly (SnAgCu)
PREHEAT	-Temperature Min(Tsmin)	150°C
	-Temperature Max(Tsmax)	200°C
	-Time(ts) form (Tsmin to Tsmax)	60-120 seconds
RAMP-UP	Avg. Ramp-up Rate (Tsmax to TP)	3°C/second(max)
REFLOW	-Temperature(TL)	217°C
	-Total Time above TL (t L)	30-100 seconds
PEAK	-Temperature(TP)	260°C
	-Time(tp)	20-30 second
RAMP-DOWN	Rate	6 °C/ second max.
Time from 25°C to Peak Temperature		8 minutes max
Composition of solder paste		96.5Sn/3Ag/0.5Cu
Solder Paste Model		SHENMAO PF606-P26

**Note:**All the temperature measure point is on top surface of the component, if temperature over recommend, it will make component surface peeling or damage.

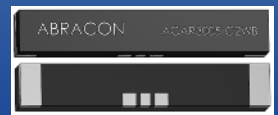

ACAR3005-C2WB



30.0 x 5.0 x 5.0 mm  
RoHS/RoHS II Compliant  
MSL = N/A

The graphic shows temperature profile for component assembly process in reflow ovens

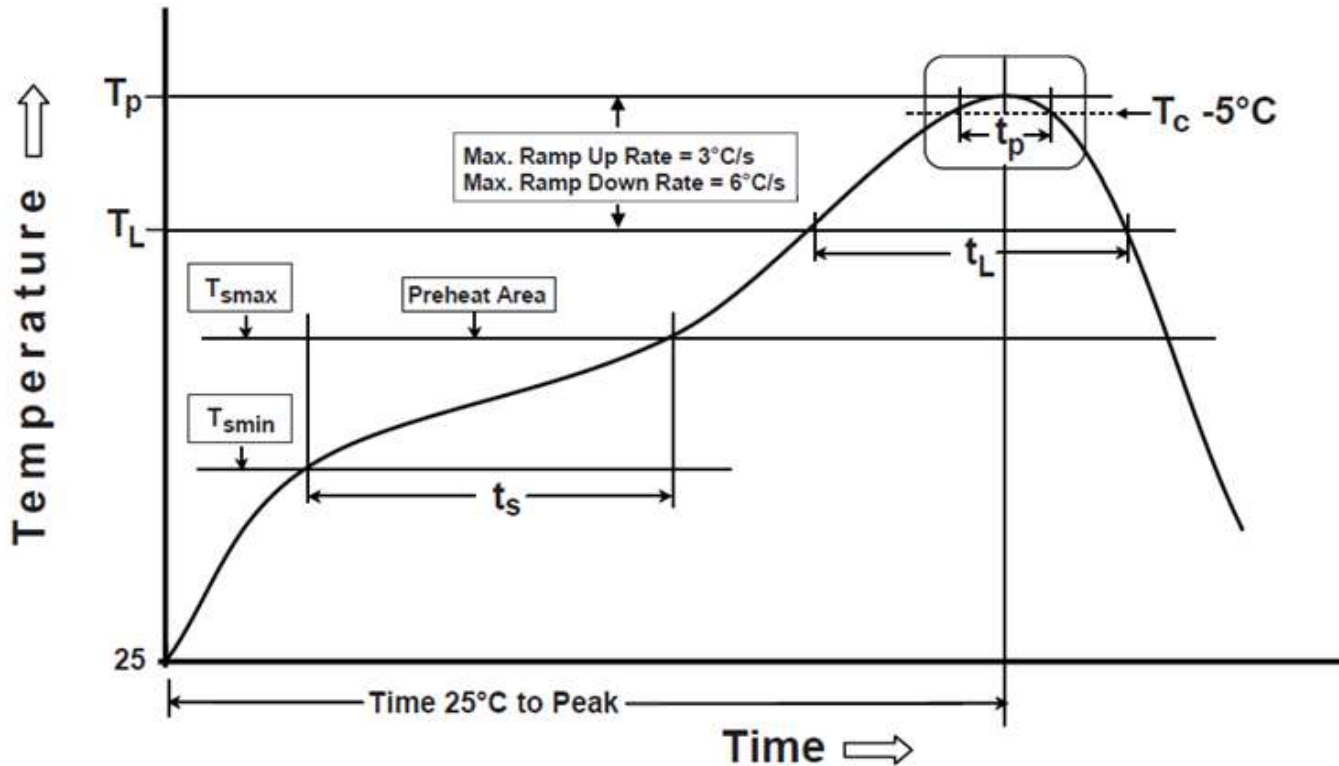

## Soldering With Iron:

Soldering condition: Soldering iron temperature  $270 \pm 10^\circ\text{C}$

Apply preheating at  $120^\circ\text{C}$  for 2-3 minutes. Finish soldering for each terminal within 3 seconds, if soldering iron over temperature  $270 \pm 10^\circ\text{C}$  or 3 seconds, it will make component surface peeling or damage.

Soldering iron cannot leak of electricity.

**ATTENTION:** Abracon LLC's products are COTS – Commercial-Off-The-Shelf products; suitable for Commercial, Industrial and, where designated, Automotive Applications. Abracon's products are not specifically designed for Military, Aviation, Aerospace, Life-dependent Medical applications or any application requiring high reliability where component failure could result in loss of life and/or property. For applications requiring high reliability and/or presenting an extreme operating environment, written consent and authorization from Abracon LLC is required. Please contact Abracon LLC for more information.