



PCF8537

Industrial LCD driver for multiplex rates up to 1:8

Rev. 1 — 31 May 2012

Product data sheet

1. General description

The PCF8537 is a fully featured Liquid Crystal Display (LCD)¹ driver, specifically designed for high-contrast Vertical Alignment (VA) LCD with multiplex rates up to 1:8. It generates the drive signals for any static or multiplexed LCD containing up to eight backplanes, 46 segments, and up to 352 elements. The PCF8537 features an internal charge pump with internal capacitors for on-chip generation of the LCD driving voltage. To ensure an optimal and stable contrast over the full temperature range, the PCF8537 offers a programmable temperature compensation of the LCD supply voltage. The PCF8537 can be easily connected to a microcontroller by either the two-line I²C-bus (PCF8537AH) or a three-line bidirectional SPI-bus (PCF8537BH).

2. Features and benefits

- Low-power single-chip LCD controller and driver
- 352 elements allowing to drive:
 - ◆ up to 44 7-segment alphanumeric characters
 - ◆ up to 22 14-segment alphanumeric characters
- Selectable backplane drive configuration: static, 2, 4, 6, or 8 backplane multiplexing
- Software programmable internal charge pump for on-chip LCD voltage generation up to 9 V with internal capacitors
- 400 kHz I²C-bus interface (PCF8537AH)
- 5 MHz SPI-bus interface (PCF8537BH)
- Programmable temperature compensation of V_{LCD} in four regions
- Selectable display bias configuration
- Wide range for digital power supply: from 1.8 V to 5.5 V
- Wide LCD supply range: from 2.5 V for low threshold LCDs and up to 9.0 V for high threshold twisted nematic LCDs
- Display memory bank switching in static, duplex, and quadruplex drive modes
- 352-bit RAM for display data storage
- Programmable frame frequency in the range of 60 Hz to 300 Hz in steps of 10 Hz; factory calibrated
- Integrated temperature sensor with temperature readout
- On chip calibration of internal oscillator frequency and V_{LCD}
- Manufactured in silicon gate CMOS process

1. The definition of the abbreviations and acronyms used in this data sheet can be found in [Section 17](#).



3. Applications

- White goods
- Handheld electronics
- Battery operated equipment
- Machine control systems
- Measuring equipment
- Information boards
- Panels
- Consumer
- Industrial
- Medical and health care

4. Ordering information

Table 1. Ordering information

Type number	Interface type	Package		
		Name	Description	Version
PCF8537AH/1	I ² C-bus	TQFP64	plastic thin quad flat package; 64 leads; body 10 × 10 × 1.0 mm	SOT357-1
PCF8537BH/1	SPI-bus	TQFP64	plastic thin quad flat package; 64 leads; body 10 × 10 × 1.0 mm	SOT357-1

5. Marking

Table 2. Marking codes

Type number	Marking code
PCF8537AH/1	PCF8537AH
PCF8537BH/1	PCF8537BH

6. Block diagram

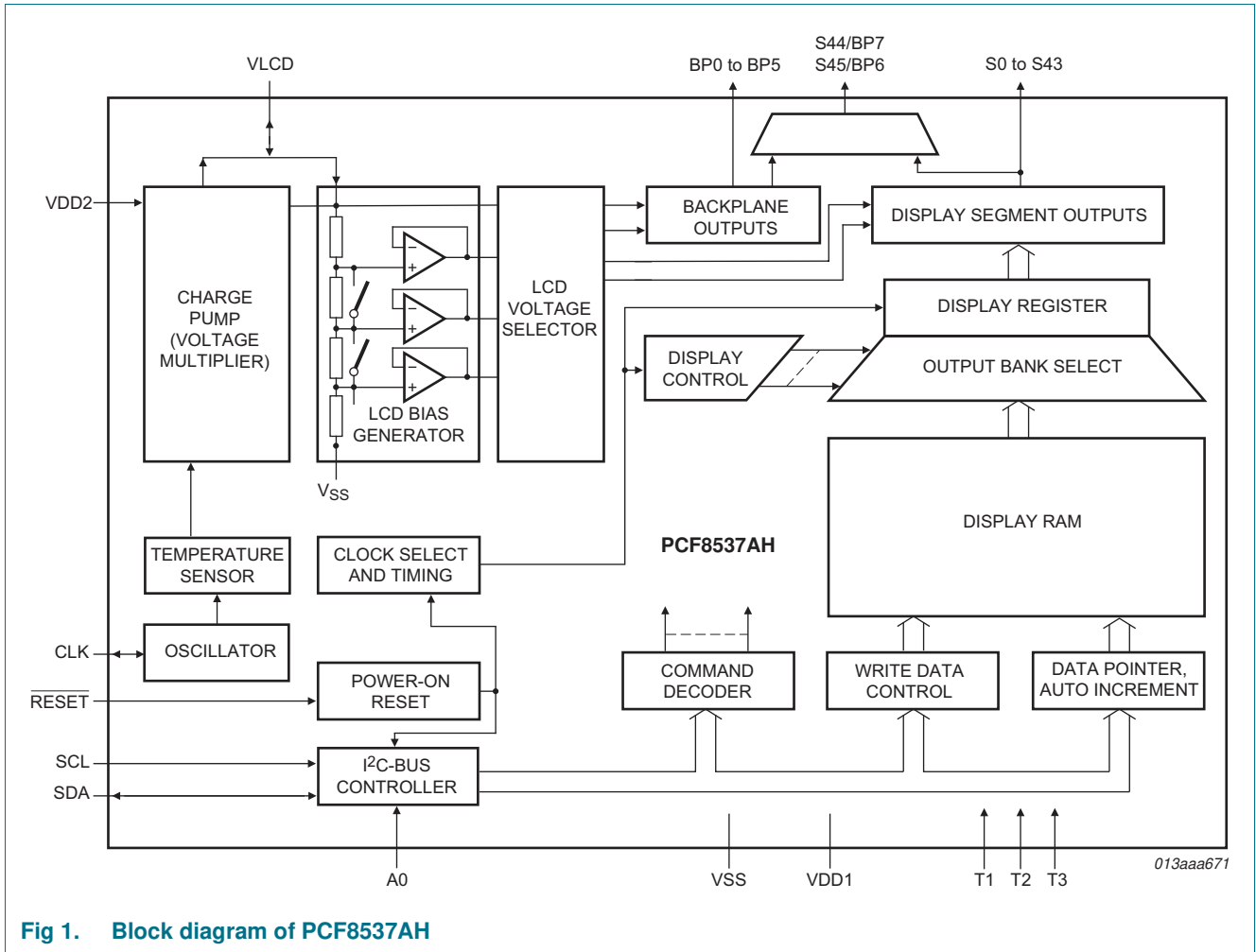

Fig 1. Block diagram of PCF8537AH

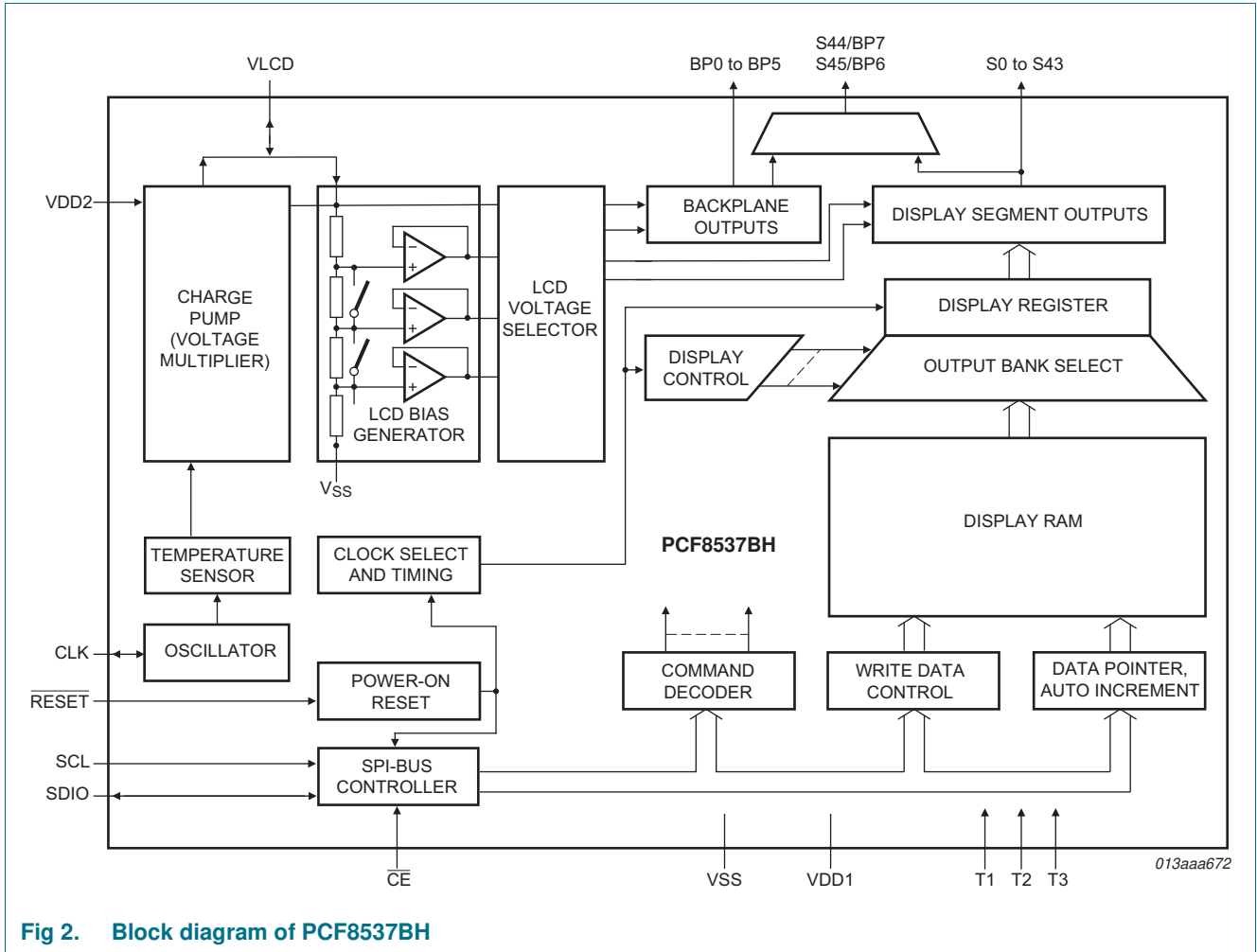
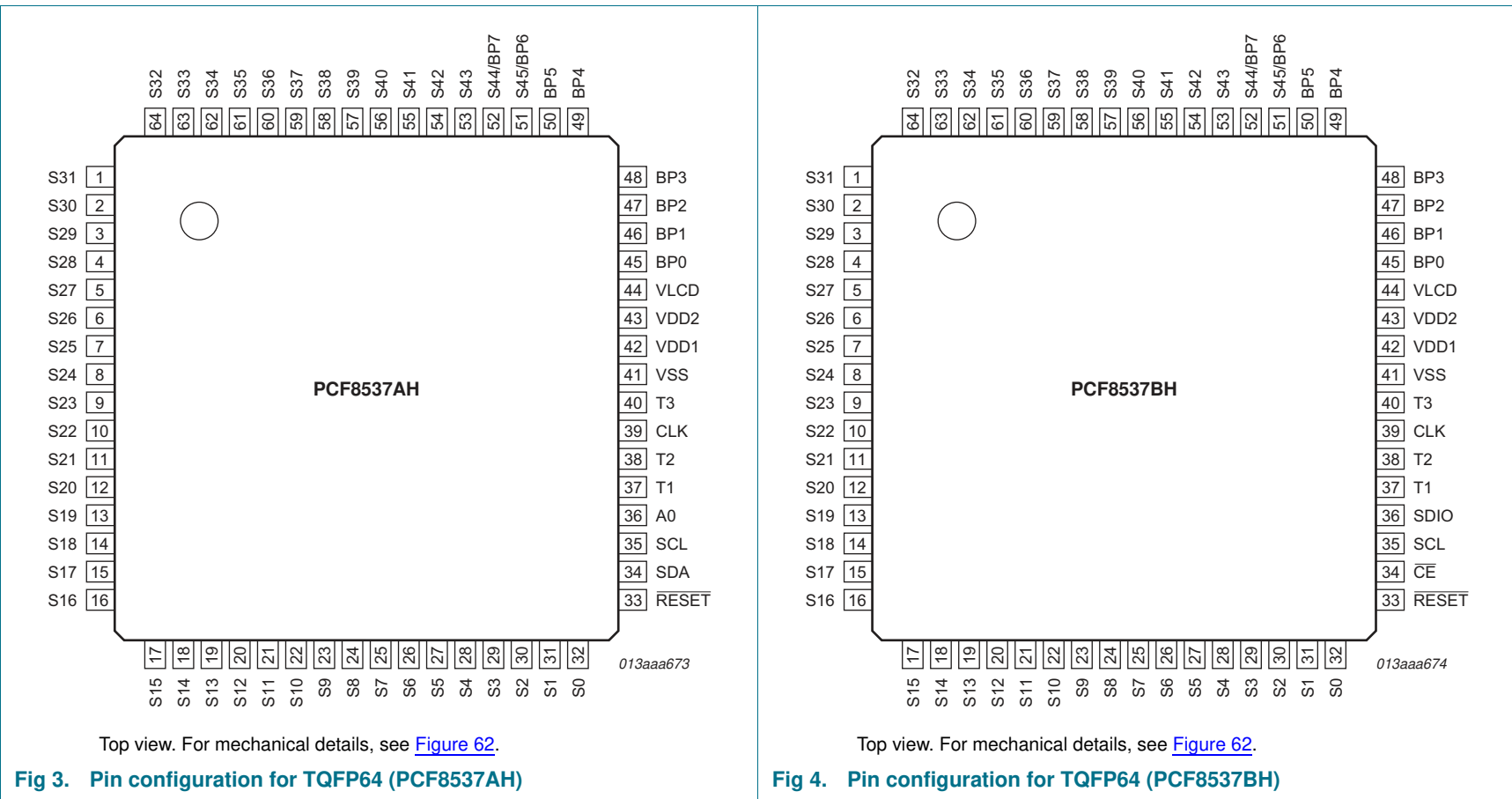

Fig 2. Block diagram of PCF8537BH

7. Pinning information

7.1 Pinning



Top view. For mechanical details, see [Figure 62](#).

Top view. For mechanical details, see [Figure 62](#).

7.2 Pin description

Table 3. Pin description of PCF8537AH and PCF8537BH

Pin	Symbol		Type	Description
	PCF8537AH	PCF8537BH		
1 to 32	S31 to S0		output	LCD segments
33	$\overline{\text{RESET}}$		input	active low reset input
34	SDA		input/output	I ² C-bus serial data
		$\overline{\text{CE}}$	input	SPI-bus chip enable - active LOW
35	SCL		input	I ² C-bus serial clock
		SCL	input	SPI-bus serial clock
36	A0		input	I ² C-bus slave address selection
		SDIO	input/output	SPI-bus serial data
37, 38, 40	T1 to T3		input	test pins; must be tied to V _{SS} in applications
39	CLK		input/output	internal oscillator output, external oscillator input
41	VSS		supply	ground supply
42	VDD1		supply	supply voltage 1
43	VDD2		supply	supply voltage 2
44	VLCD ^[1]		supply	LCD supply ^[2]
45 to 50	BP0 to BP5		output	LCD backplanes
51	S45/BP6		output	LCD segments for 1:6 multiplex drive mode;
52	S44/BP7		output	LCD backplanes for 1:8 multiplex drive mode
53 to 64	S43 to S32		output	LCD segments

[1] V_{LCD} must be equal to or greater than V_{DD2}.

[2] When the internal V_{LCD} generation is used, this pin drives the V_{LCD} voltage. In this case pin VLCD is an output. When the external supply is requested, then pin VLCD is an input and V_{LCD} can be supplied on it. In this case, the internal charge pump must be disabled (see [Table 8](#)).

8. Functional description

The PCF8537 is a versatile peripheral device designed to interface any microcontroller to a wide variety of LCDs. It can directly drive any static or multiplexed LCD containing up to 352 elements.

8.1 Commands of PCF8537

The commands to control the PCF8537 are defined in [Table 4](#). Any other combinations of operation code bits that are not mentioned in this document can lead to undesired operation modes of PCF8537.

Table 4. Commands of PCF8537

The bit labeled with - is not implemented.

Command name	RS ^[1]	Bits								Reference
		7	6	5	4	3	2	1	0	
Initialize	0	0	0	1	1	1	0	1	0	Section 8.1.1
OTP-refresh	0	1	1	0	1	0	0	0	0	Section 8.1.2
Oscillator-ctrl	0	1	1	0	0	1	1	COE	OSC	Section 8.1.3
Charge-pump-ctrl	0	1	1	0	0	0	0	CPE	CPC	Section 8.1.4
Temp-msr-ctrl	0	1	1	0	0	1	0	TCE	TME	Section 8.1.5
Temp-comp	0	0	0	0	1	1	SLA[2:0]		Section 8.1.6	
	0	0	0	1	0	0	SLB[2:0]			
	0	0	0	1	0	1	SLC[2:0]			
	0	0	0	1	1	0	SLD[2:0]			
Set-VPR	0	0	1	0	0	VPR[7:4]			Section 8.1.7	
	0	0	1	0	1	VPR[3:0]				
Display-enable	0	0	0	1	1	1	0	0	E	Section 8.1.8
Set-MUX-mode	0	0	0	0	0	0	M[2:0]		Section 8.1.9	
Set-bias-mode	0	1	1	0	0	0	1	B[1:0]		Section 8.1.10
Load-data-pointer	0	1	0	P[5:0]			Section 8.1.11			
Frame-frequency	0	0	1	1	F[4:0]			Section 8.1.12		
Bank-select	0	0	0	0	0	1	0	IBS	OBS	Section 8.1.13
Write-RAM-data	1	B[7:0]								Section 8.1.14
Temp-read	-	TD[7:0]								Section 8.1.15
Invmode_ctrl	0	1	1	0	1	0	1	LF	0	Section 8.1.16
Temp-filter	0	1	1	0	1	0	0	1	TFE	Section 8.1.17

[1] For further information about the register selection bit, see [Table 30 on page 52](#).

8.1.1 Command: Initialize

This command generates a chip-wide reset which resets all command values to their default values. After this command is sent, it is possible to send additional commands without the need to re-initialize the interface. The reset takes 100 ns to complete.

Table 5. Initialize - initialize command bit description

For further information, see [Section 8.2 on page 17](#).

Bit	Symbol	Binary value	Description
7 to 0	-	00111010	fixed value

8.1.2 Command: OTP-refresh

During production and testing of the device, each IC is calibrated to achieve the specified accuracy of V_{LCD} , the frame frequency, and the temperature measurement. This calibration is performed on EPROM cells called One Time Programmable (OTP) cells.

The device reads these cells every time at power-on, after a reset, and every time when the initialize command or the OTP-refresh command is sent.

Remark: It is recommended not to enter power-down mode during the OTP refresh cycle.

Table 6. OTP-refresh - OTP-refresh command bit description

Bit	Symbol	Binary value	Description
7 to 0	-	11010000	fixed value

8.1.3 Command: Oscillator-ctrl

The Oscillator-ctrl command switches between internal and external oscillator and enables or disables the pin CLK.

Table 7. Oscillator-ctrl - oscillator control command bit description

For further information, see [Section 8.1.3.1](#).

Bit	Symbol	Binary value	Description
7 to 2	-	110011	fixed value
1	COE		control pin CLK
		0 ^[1]	clock signal not available on pin CLK; pin CLK is in 3-state and may be left floating
		1	clock signal available on pin CLK
0	OSC		oscillator source
		0 ^[1]	internal oscillator used
		1	external oscillator used; pin CLK becomes an input

[1] Default value.

8.1.3.1 Oscillator

The internal logic and LCD drive signals of the PCF8537 are timed either by the built-in oscillator or from an external clock.

8.1.3.2 Internal oscillator

When the internal oscillator is used, it is possible to make the clock signal available on pin CLK by using the Oscillator-ctrl command (see [Table 7](#)). If this is not intended, the pin CLK should be left open. At power-on the signal at pin CLK is disabled and pin CLK is in 3-state.

If the internal charge pump is enabled, then the internal oscillator starts and is used to run the charge pump. An external oscillator can still be applied for driving the display waveforms.

The duty cycle of the output clock provided on the CLK pin is not always 50 : 50. [Table 17 on page 13](#) shows the expected duty cycle for each of the chosen frame frequencies.

8.1.3.3 External clock

In applications where an external clock must be applied to the PCF8537, bit OSC (see [Table 7](#)) must be set logic 1. In this case, pin CLK becomes an input.

The CLK signal is a signal that is fed into the V_{DD1} domain. Therefore it must have an amplitude equal to the V_{DD1} voltage supplied to the chip and be referenced to V_{SS} .

The clock frequency (f_{clk}) determines the LCD frame frequency.

Remark: If an external clock is used then this clock signal must always be supplied to the device. Removing the clock can freeze the LCD in a DC state. Removal of the clock is possible when following the correct procedures (see [Figure 11 on page 21](#) and [Figure 12 on page 22](#)).

8.1.4 Command: Charge-pump-ctrl

The Charge-pump-ctrl command enables or disables the internal V_{LCD} generation and controls the charge pump voltage multiplier setting.

Table 8. Charge-pump-ctrl - charge pump control command bit description

For further information, see [Table 11 on page 11](#) and [Section 8.4.3 on page 26](#).

Bit	Symbol	Binary value	Description
7 to 2	-	110000	fixed value
1	CPE		charge pump switch
		0 ^[1]	charge pump disabled; no internal V_{LCD} generation; external supply of V_{LCD}
		1	charge pump enabled
0	CPC		charge pump voltage multiplier setting
		0 ^[1]	$V_{LCD} = 2 \times V_{DD2}$
		1	$V_{LCD} = 3 \times V_{DD2}$

[1] Default value.

8.1.5 Command: Temp-msr-ctrl

The Temp-msr-ctrl command enables or disables the temperature measurement block and the temperature compensation of V_{LCD} .

Table 9. Temp-msr-ctrl - temperature measurement control command bit description

For further information, see [Section 8.4.4 on page 28](#).

Bit	Symbol	Binary value	Description
7 to 2	-	110010	fixed value
1	TCE		temperature compensation switch
		0	no temperature compensation of V_{LCD} possible
		1 ^[1]	temperature compensation of V_{LCD} possible
0	TME		temperature measurement switch
		0	temperature measurement disabled: no temperature readout possible
		1 ^[1]	temperature measurement enabled: temperature readout possible

[1] Default value.

8.1.6 Command: Temp-comp

The Temp-comp command allows setting the temperature compensation coefficients for each of the temperature regions SFA to SFD. For further information, see [Section 8.4.4.2](#).

Table 10. Temp-comp - temperature compensation coefficients command

For further information, see [Section 8.4.4 on page 28](#).

Bit	Symbol	Binary value	Description
SLA			
7 to 3	-	00011	fixed value
2 to 0	SLA[2:0]	000 ^[1] to 111	temperature compensation coefficient SLA , see Table 26 on page 30
SLB			
7 to 3	-	00100	fixed value
2 to 0	SLB[2:0]	000 ^[1] to 111	temperature compensation coefficient SLB , see Table 26 on page 30
SLC			
7 to 3	-	00101	fixed value
2 to 0	SLC[2:0]	000 ^[1] to 111	temperature compensation coefficient SLC , see Table 26 on page 30
SLD			
7 to 3	-	00110	fixed value
2 to 0	SLD[2:0]	000 ^[1] to 111	temperature compensation coefficient SLD , see Table 26 on page 30

[1] Default value.

8.1.7 Command: Set-VPR

With these two instructions, it is possible to set the target V_{LCD} voltage for the internal charge pump.

Table 11. Set-VPR - set VPR command bit description

For further information, see [Section 8.4.2 on page 25](#).

Bit	Symbol	Binary value	Description
Set-VPR MSB			
7 to 4	-	0100	fixed value
3 to 0	VPR[7:4]	0000 ^[1] to 1111 ^[2]	the four most significant bits of VPR[7:0]
Set-VPR LSB			
7 to 4	-	0101	fixed value
3 to 0	VPR[3:0]	0000 ^[1] to 1111 ^[2]	the four least significant bits of VPR[7:0]

[1] Default value.

[2] VPR[7:0] = 0h results in $V_{prog(LCD)} = 3\text{ V}$;
VPR[7:0] = C8h results in $V_{prog(LCD)} = 9\text{ V}$.

8.1.8 Command: Display-enable

This command allows switching the display on and off. The possibility to disable and enable the display allows implementation of blinking the entire display under external control.

Table 12. Display-enable - display enable command bit description

Bit	Symbol	Binary value	Description
7 to 1	-	0011100	fixed value
0	E	0 ^[1]	display disabled backplane and segment outputs are internally connected to V_{SS}
		1	display enabled

[1] Default value.

8.1.9 Command: Set-MUX-mode

The multiplex drive mode is configured with the bits described in [Table 13](#).

Table 13. Set-MUX-mode - set multiplex drive mode command bit description

For further information, see [Section 8.4.5 on page 31](#).

Bit	Symbol	Binary value	Description
7 to 3	-	00000	fixed value
2 to 0	M[2:0]	000 ^[1]	1:8 multiplex drive mode
		011	8 backplanes and 44 segments
		101	
		111	
		110	1:6 multiplex drive mode
			6 backplanes and 46 segments
		100	1:4 multiplex drive mode
			4 backplanes and 44 segments
		010	1:2 multiplex drive mode
			2 backplanes and 44 segments
		001	static drive mode
			1 backplane and 44 segments

[1] Default value.

8.1.10 Command: Set-bias-mode

The Set-bias-mode command allows setting the bias level.

Table 14. Set-bias-mode - set bias mode command bit description

For further information, see [Section 8.4.5 on page 31](#).

Bit	Symbol	Binary value	Description
7 to 2	-	110001	fixed value
1 to 0	B[1:0]		LCD bias configuration^[1]
		00 ^[2]	$\frac{1}{4}$ bias
		01	
		11	$\frac{1}{3}$ bias
		10	$\frac{1}{2}$ bias

[1] Not applicable for static drive mode.

[2] Default value.

8.1.11 Command: Load-data-pointer

The Load-data-pointer command defines the display RAM address where the following display data will be sent to.

Table 15. Load-data-pointer - load data pointer command bit description

For further information, see [Section 8.8 on page 44](#).

Bit	Symbol	Binary value	Description
7 to 6	-	10	fixed value
5 to 0	P[5:0]	000000 to 101101	RAM address 6-bit binary value of 0 to 45

8.1.12 Command: Frame-frequency

With the Frame-frequency command, the frame frequency and the output clock frequency can be configured.

Table 16. Frame frequency - frame frequency and output clock frequency command bit description

Bit	Symbol	Binary value	Description
7 to 5	-	011	fixed value
4 to 0	F[4:0]	see Table 17	frame frequency values, see Table 17

Table 17. Frame frequency values

F[4:0]	Nominal frame frequency f_{fr} (Hz) ^[1]	Resultant output clock frequency, $f_{clk(o)}$ (Hz)	Duty cycle (%) ^[2]
00000	60	2880	20 : 80
00001	70	3360	7 : 93
00010	80	3840	47 : 53
00011	91	4368	40 : 60
00100	100	4800	33 : 67
00101	109	5232	27 : 73
00110	120	5760	20 : 80
00111	129.7	6226	13 : 87
01000	141.2	6778	5 : 95
01001	150	7200	50 : 50
01010	160	7680	47 : 53
01011	171.4	8227	43 : 57
01100	177.8	8534	41 : 59
01101	192	9216	36 : 64
01110 ^[3]	200	9600	33 : 67
01111	208.7	10018	30 : 70
10000	218.2	10474	27 : 73
10001	228.6	10973	23 : 77
10010	240	11520	20 : 80
10011	252.6	12125	16 : 84
10100, 10101	266.7	12802	10 : 90
10110, 10111	282.4	13555	5 : 95
11000 to 11111	300	14400	50 : 50

[1] Nominal frame frequency calculated for the default clock frequency of 9600 Hz.

[2] Duty cycle definition: % HIGH-level time : % LOW-level time.

[3] Default value.

8.1.12.1 Timing and frame frequency

The timing of the PCF8537 organizes the internal data flow of the device. This includes the transfer of display data from the display RAM to the display segment outputs. The timing also generates the LCD frame frequency. The frame frequency is a fixed division of the internal clock or of the frequency applied to pin CLK when an external clock is used.

When the internal clock is used, the clock frequency can be programmed by software such that the nominal frame frequency can be chosen in steps of 10 Hz in the range of 60 Hz to 300 Hz (see [Table 17](#)). Furthermore the nominal frame frequency is factory-calibrated with an accuracy of ±15 %.

When the internal clock is enabled at pin CLK by using bit COE, the duty ratio of the clock may change when choosing different values for the frame frequency prescaler. [Table 17](#) shows the different output duty ratios for each frame frequency prescaler setting.

8.1.13 Command: Bank-select

For the multiplex drive modes 1:4, 1:2, and the static drive mode, it is possible to write data to one area of the RAM while displaying from another. These areas are named RAM banks. There are two banks, 0 and 1. [Figure 39 on page 50](#) and [Figure 40 on page 50](#) show the concept. The Bank-select command controls where data is written to and where it is displayed from.

Table 18. Bank-select - bank select command bit description

For further information, see [Section 8.9 on page 50](#).

Bit	Symbol	Binary value	Description
7 to 2	-	000010	fixed value
1	IBS		selects RAM bank to write to
		0 ^[1]	Bank 0
		1	Bank 1
0	OBS		selects RAM bank to read from to the LCD
		0 ^[1]	Bank 0
		1	Bank 1

[1] Default value.

8.1.14 Command: Write-RAM-data

By setting the RS bit of the control byte to logic 1, all data transferred is interpreted as RAM data and placed in the RAM in accordance with the current setting of the RAM address pointer (see [Section 8.1.11 on page 12](#)). Definition of the RS can be found in [Table 30 on page 52](#).

Remark: After Power-On Reset (POR) the RAM content is random and should be brought to a defined status by clearing it (setting it to logic 0).

Table 19. Write-RAM-data - write RAM data command bit description

For further information, see [Section 8.8 on page 44](#).

Bit	Symbol	Binary value	Description
7 to 0	B[7:0]	00000000 to 11111111	writing data byte-wise to the RAM

8.1.15 Command: Temp-read

The Temp-read command allows reading out the temperature values measured by the internal temperature sensor.

Table 20. Temp-read - temperature readout command bit description

For further information, see [Section 8.4.4 on page 28](#).

Bit	Symbol	Binary value	Description
7 to 0	TD[7:0]	00000000 to 11111111	digital temperature values ^[1]

[1] For this command, bit $\overline{R/W}$ of the I²C-bus slave address byte has to be set logic 1 (see [Table 31](#)).

8.1.16 Command: Invmode_ctrl

The Invmode_ctrl command allows changing the drive scheme inversion mode.

The waveforms used to drive LCD displays inherently produce a DC voltage across the display cell. The PCF8537 compensates for the DC voltage by inverting the waveforms on alternate frames or alternate lines. The choice of compensation method is determined with the LF bit.

Table 21. Invmode_ctrl - drive scheme inversion command bit description

For further information, see [Section 8.4.6 on page 34](#).

Bit	Symbol	Binary value	Description
7 to 2	-	110101	fixed value
1	LF		set inversion mode
		0 ^[1]	driving scheme A: line inversion mode
		1	driving scheme B: frame inversion mode
0	-	0	fixed value

[1] Default value.

In frame inversion mode, the DC value is compensated across two frames and not within one frame. Changing the inversion mode to frame inversion reduces the power consumption, therefore it is useful when power consumption is a key point in the application.

Frame inversion may not be suitable for all applications. The RMS voltage across a segment is better defined, however since the switching frequency is reduced there is possibility for flicker to occur.

[Figure 24 on page 34](#) to [Figure 30 on page 40](#) are showing the waveforms in line inversion mode. [Figure 31 on page 41](#) shows an example of frame inversion.

8.1.17 Command: Temp-filter

Table 22. Temp-filter - digital temperature filter command bit description

For further information, see [Section 8.4.4 on page 28](#).

Bit	Symbol	Binary value	Description
7 to 1	-	1101001	fixed value
0	TFE		digital temperature filter switch
		0 ^[1]	digital temperature filter disabled; the unfiltered digital value of TD[7:0] is immediately available for the readout and V _{LCD} compensation, see Section 8.4.4.1
		1	digital temperature filter enabled

[1] Default value.

8.2 Start-up and shut-down

8.2.1 Power-On Reset (POR)

At power-on, the PCF8537 resets to starting conditions as follows:

1. All backplane and segment outputs are set to V_{SS} .
2. Selected drive mode is: 1:8 with $\frac{1}{4}$ bias.
3. Input and output bank selectors are reset.
4. The I²C-bus and SPI-bus interface are initialized.
5. The data pointer is cleared (set logic 0).
6. The internal oscillator is running; no clock signal is available on pin CLK; pin CLK is in 3-state.
7. Temperature measurement is enabled.
8. Temperature filter is disabled.
9. The internal V_{LCD} voltage generation is disabled. The charge pump is switched off.
10. The V_{LCD} temperature compensation is enabled.
11. The display is disabled.

The reset state is as shown in [Table 23](#).

Table 23. Reset state

Reset state of configuration bits shown in the command table format for clarity. The bit labeled with - has an undefined reset state.

Command name	Bits							
	7	6	5	4	3	2	1	0
Oscillator-ctrl	1	1	0	0	1	1	COE = 0	OSC = 0
Charge-pump-ctrl	1	1	0	0	0	0	CPE = 0	CPC = 0
Temp-msr-ctrl	1	1	0	0	1	0	TCE = 1	TME = 1
Temp-comp	0	0	0	1	1	SLA[2:0] = 000		
	0	0	1	0	0	SLB[2:0] = 000		
	0	0	1	0	1	SLC[2:0] = 000		
	0	0	1	1	0	SLD[2:0] = 000		
Set-VPR	0	1	0	0	VPR[7:4] = 0000			
	0	1	0	1	VPR[3:0] = 0000			
Display-enable	0	0	1	1	1	0	0	E = 0
Set-MUX-mode	0	0	0	0	0	M[2:0] = 000		
Set-bias-mode	1	1	0	0	0	1	B[1:0] = 00	
Load-data-pointer	1	0	P[5:0] is undefined					
Frame-frequency	0	1	1	F[4:0] = 01110				
Bank-select	0	0	0	0	1	0	IBS = 0	OBS = 0
Invmode_ctrl	1	1	0	1	0	1	LF = 0	-
Temp-filter	1	1	0	1	0	0	1	TFE = 0

Remark: Do not transfer data on the I²C-bus or SPI-bus for at least 1 ms after a power-on reset to allow the reset action to complete.

The first command sent to the device after the power-on event must be the Initialize command (see [Section 8.1.1](#)).

After POR and before enabling the display, the RAM content should be brought to a defined status

- by clearing it (setting it all to logic 0) or
- by writing meaningful content (for example, a graphic)

otherwise unwanted display artifacts may appear on the display.

8.2.2 RESET pin function

The RESET pin of the PCF8537 resets all the registers to their default state. The reset state is given in [Table 23](#). The RAM contents remain unchanged. After the reset signal is removed, the PCF8537 will behave in the same manner as after POR. See [Section 8.2.1](#) for details.

8.2.3 Recommended start-up sequences

This chapter describes how to proceed with the initialization of the chip in different application modes.

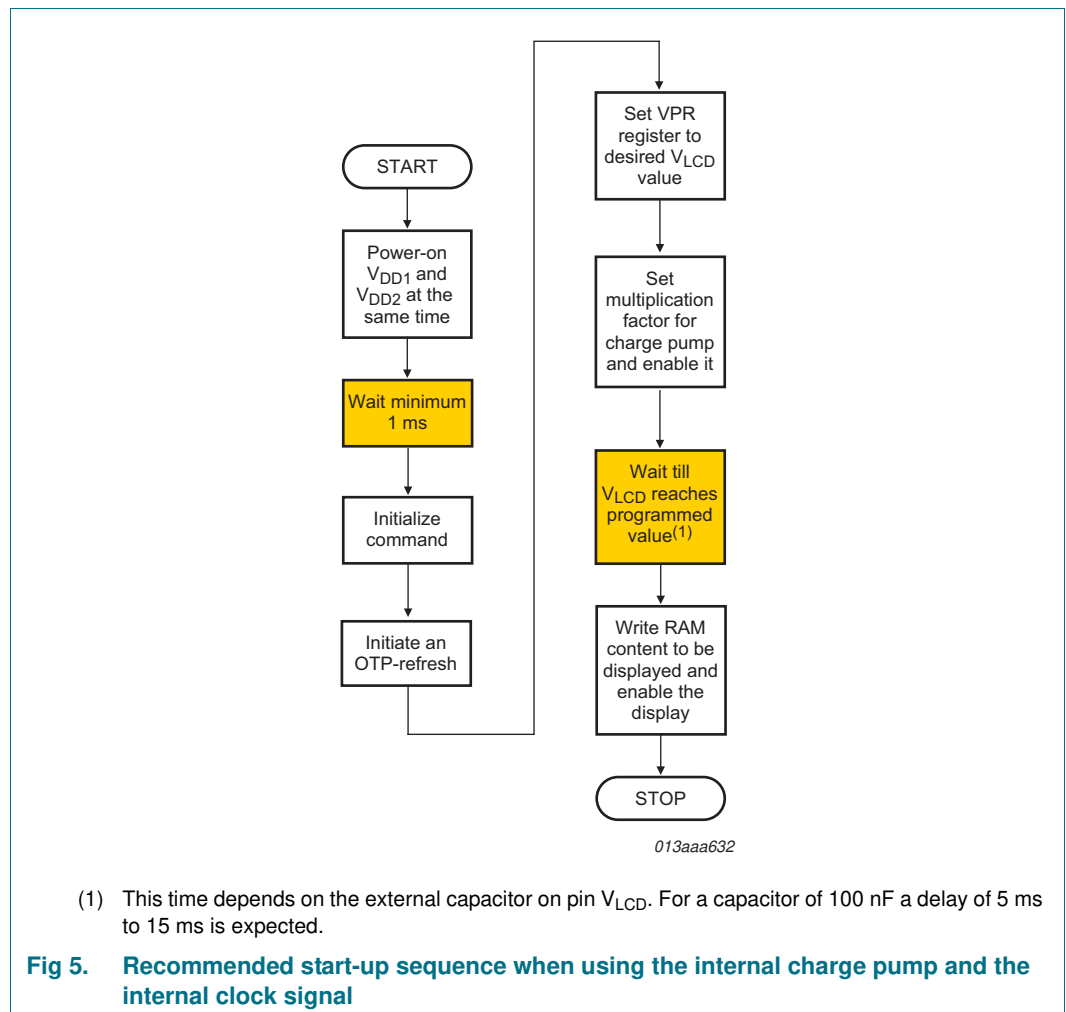

If the display is enabled too soon after the charge pump is enabled, then the V_{LCD} voltage may not have yet stabilized leading to an uneven display effect.

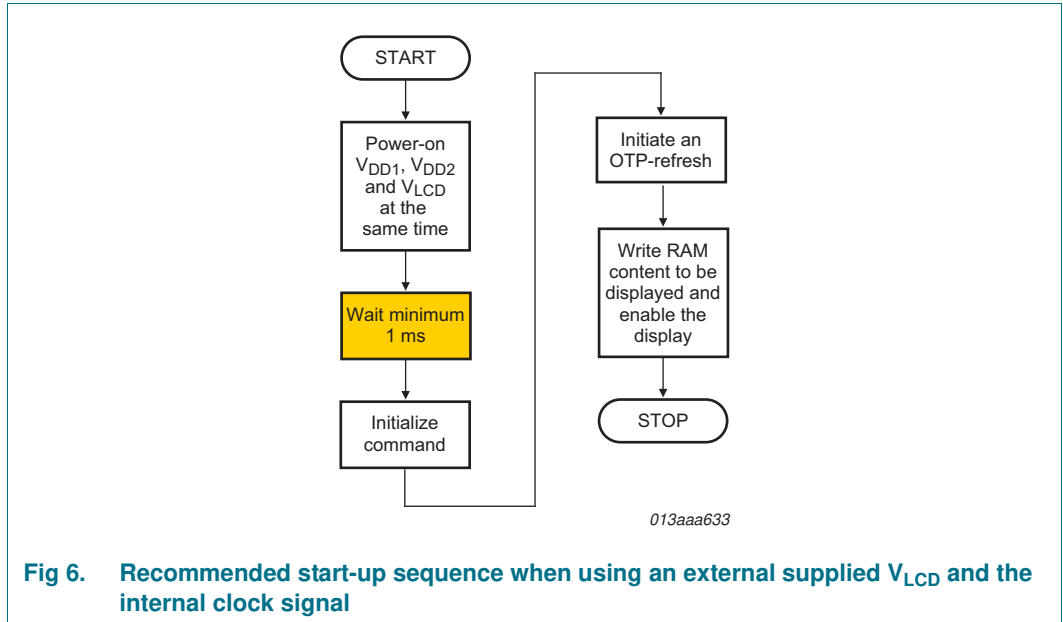
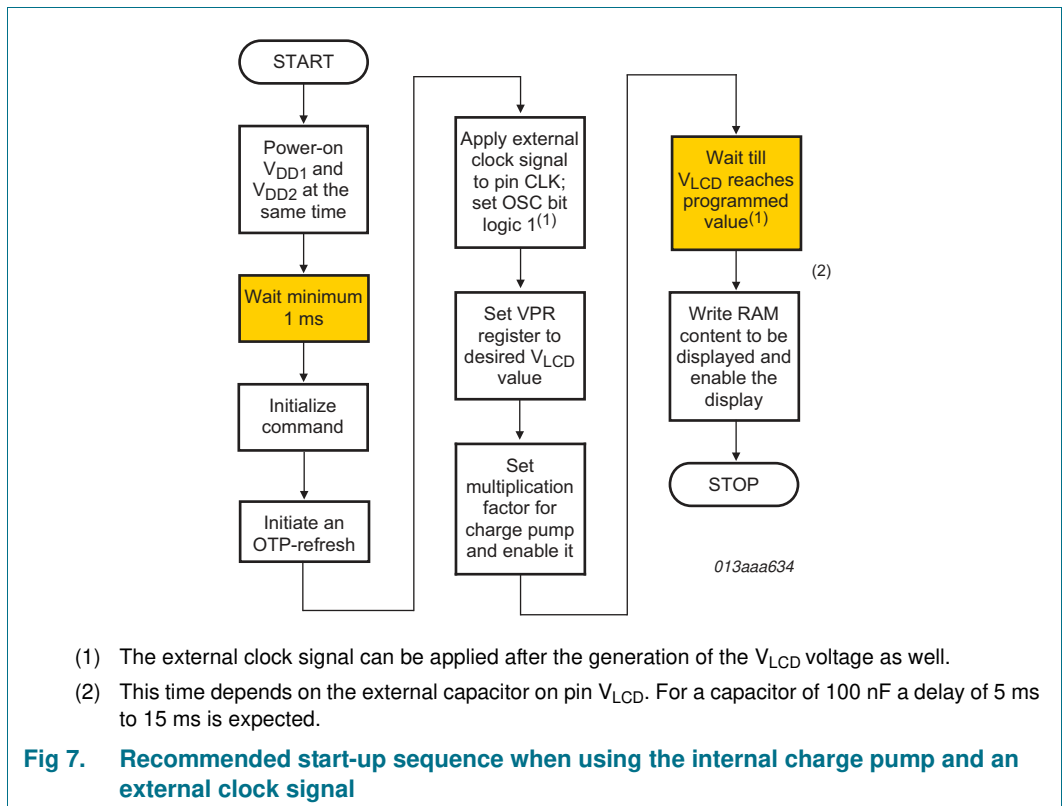

Fig 6. Recommended start-up sequence when using an external supplied V_{LCD} and the internal clock signal



- (1) The external clock signal can be applied after the generation of the V_{LCD} voltage as well.
- (2) This time depends on the external capacitor on pin V_{LCD} . For a capacitor of 100 nF a delay of 5 ms to 15 ms is expected.

Fig 7. Recommended start-up sequence when using the internal charge pump and an external clock signal

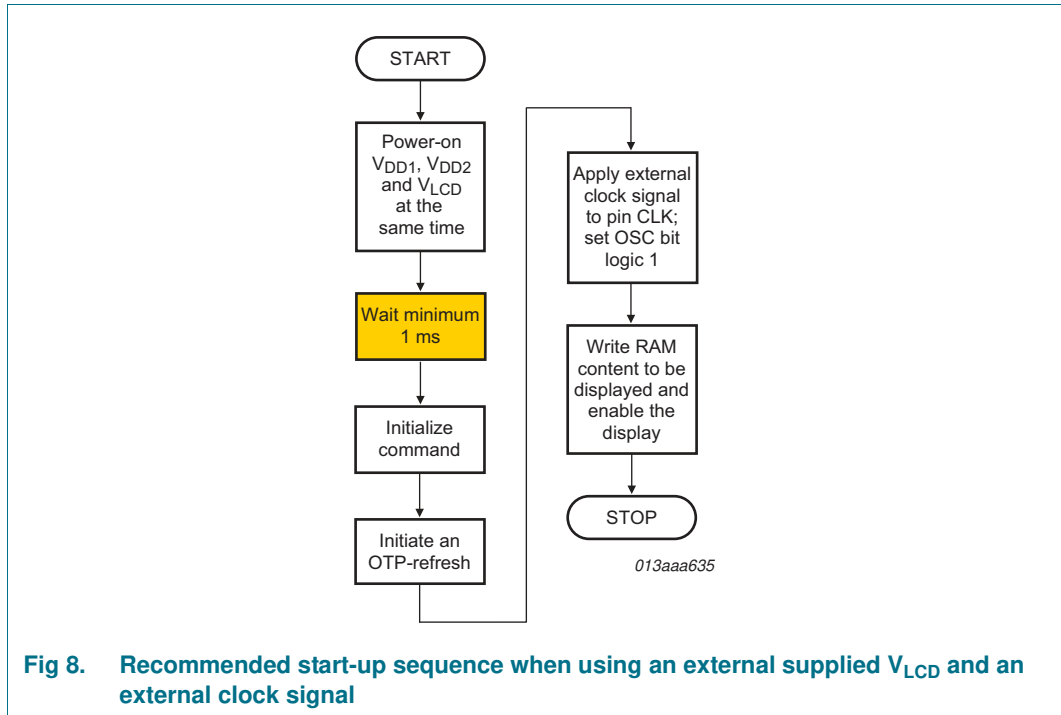

Fig 8. Recommended start-up sequence when using an external supplied V_{LCD} and an external clock signal

8.2.4 Recommended sequences to enter power-down mode

With the following sequences, the PCF8537 can be set to a state of minimum power consumption, called power-down mode.

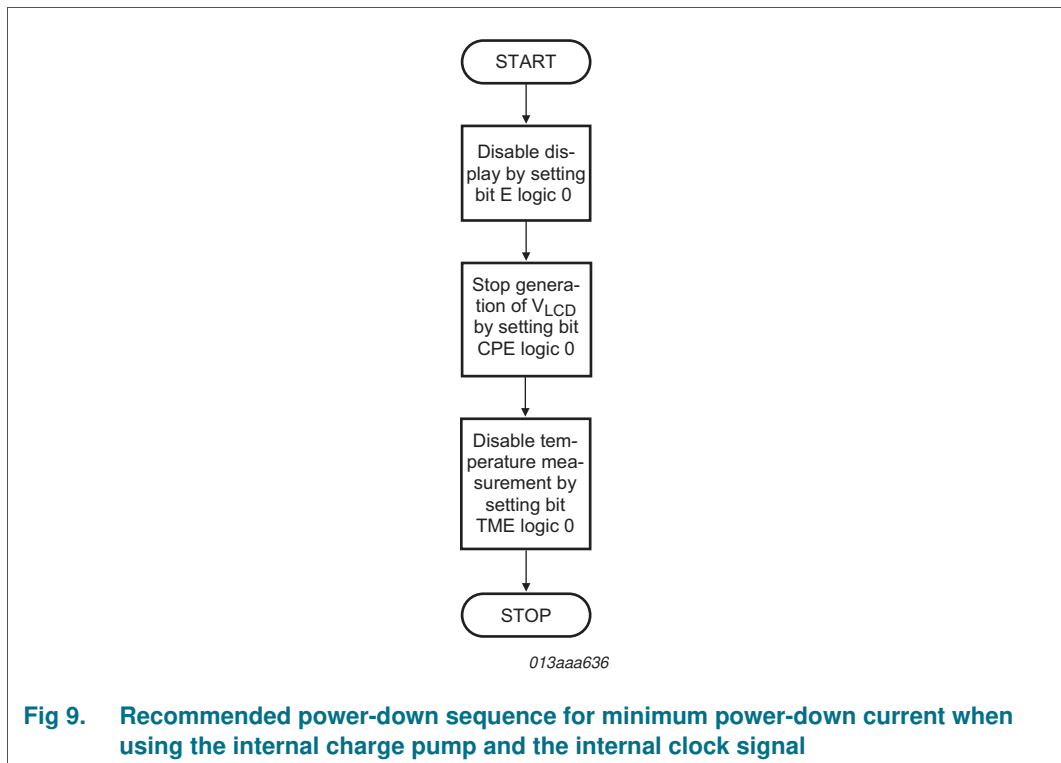

Fig 9. Recommended power-down sequence for minimum power-down current when using the internal charge pump and the internal clock signal

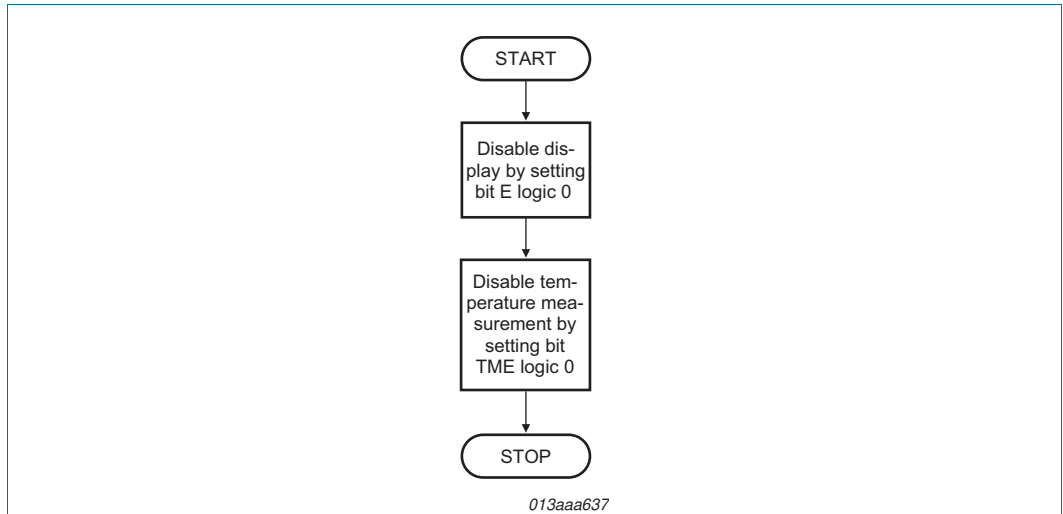

Fig 10. Recommended power-down sequence when using an external supplied V_{LCD} and the internal clock signal

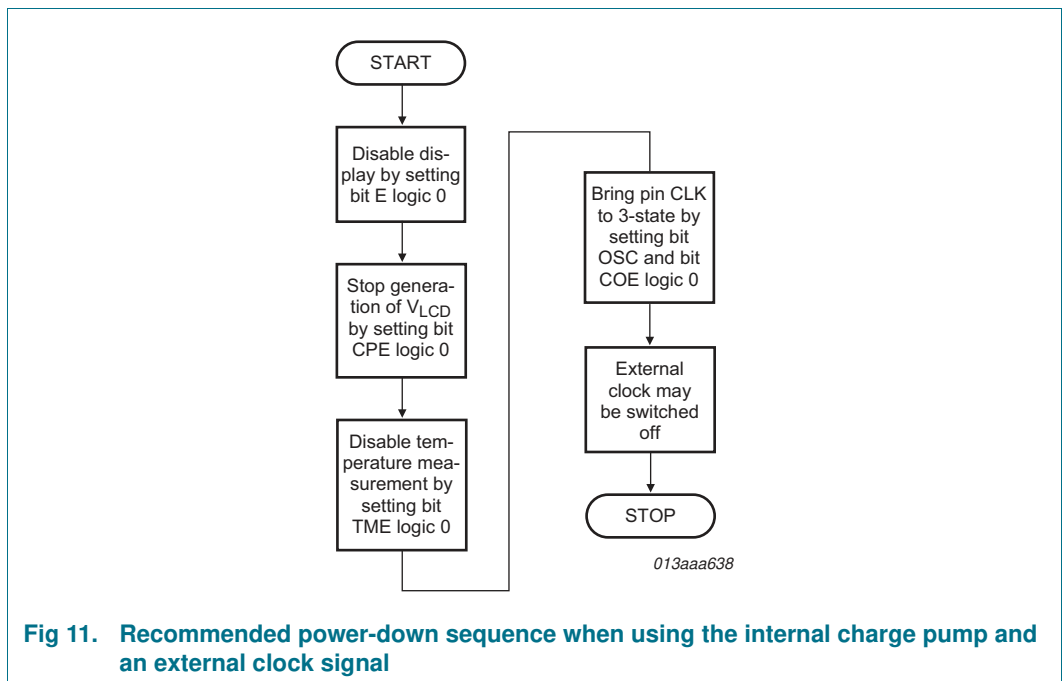
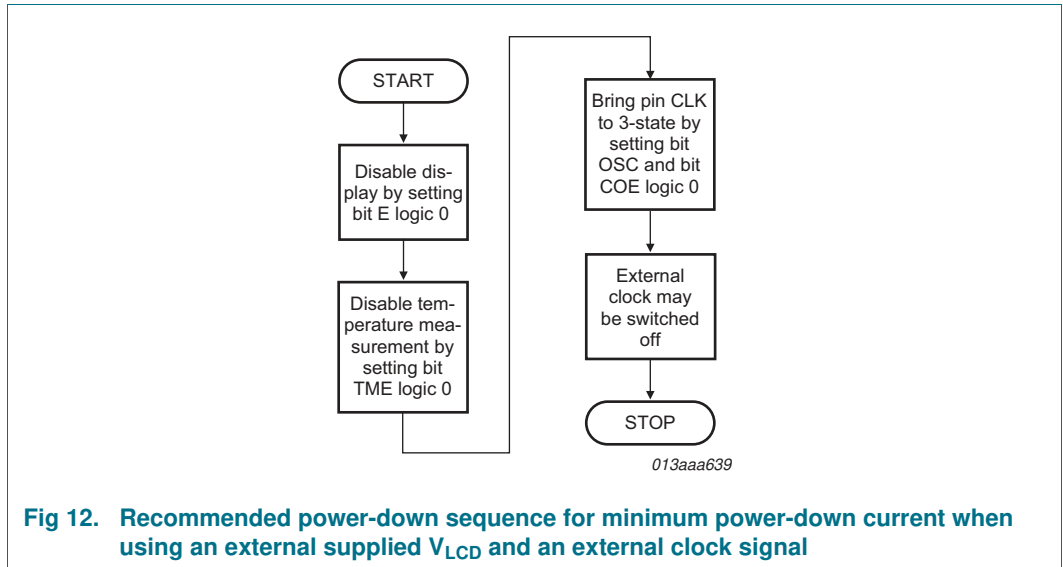

Fig 11. Recommended power-down sequence when using the internal charge pump and an external clock signal



Remark: It is necessary to run the power-down sequence before removing the supplies. Depending on the application, care must be taken that no other signals are present at the chip input or output pins when removing the supplies (see [Section 10](#)). Otherwise this may cause unwanted display artifacts. In the case of uncontrolled removal of supply voltages the PCF8537 will not be damaged.

Remark: Static voltages across the liquid crystal display can build up when the external LCD supply voltage (V_{LCD}) is on while the IC supply voltage (V_{DD1} or V_{DD2}) is off, or the other way around. This may cause unwanted display artifacts. To avoid such artifacts, V_{LCD} , V_{DD1} , and V_{DD2} must be applied or removed together.

Remark: A clock signal must always be supplied to the device when the display is active. Removing the clock may freeze the LCD in a DC state, which is not suitable for the liquid crystal. It is recommended to first disable the display and afterwards to remove the clock signal.

8.3 Possible display configurations

The PCF8537 is a versatile peripheral device designed to interface between any microcontroller to a wide variety of LCD segment or dot matrix displays (see [Figure 13](#)). It can directly drive any static or multiplexed LCD containing up to eight backplanes with 44 segments.

The display configurations possible with the PCF8537 depend on the number of active backplane outputs required. A selection of possible display configurations is given in [Table 24](#).

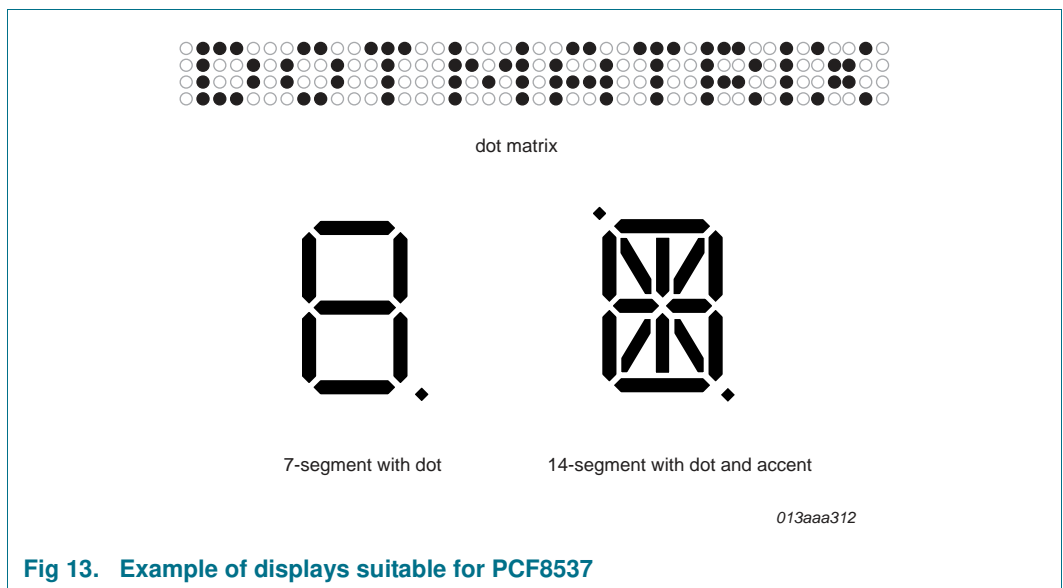

Fig 13. Example of displays suitable for PCF8537

Table 24. Selection of display configurations

Number of			Digits/Characters		Dot matrix/ Elements
Backplanes	Segments	Icons	7 segment ^[1]	14 segment ^[2]	
8	44	352	44	22	352 dots (8 × 44)
6	46	276	34	17	276 dots (6 × 46)
4	44	176	22	11	176 dots (4 × 44)
2	44	88	11	5	88 dots (2 × 44)
1	44	44	5	2	44 dots (1 × 44)

[1] 7 segment display has 8 elements including the decimal point.

[2] 14 segment display has 16 elements including decimal point and accent dot.

All of the display configurations in [Table 24](#) can be implemented in the typical systems shown in [Figure 14](#) (internal V_{LCD}) and in [Figure 15](#) (external V_{LCD}).

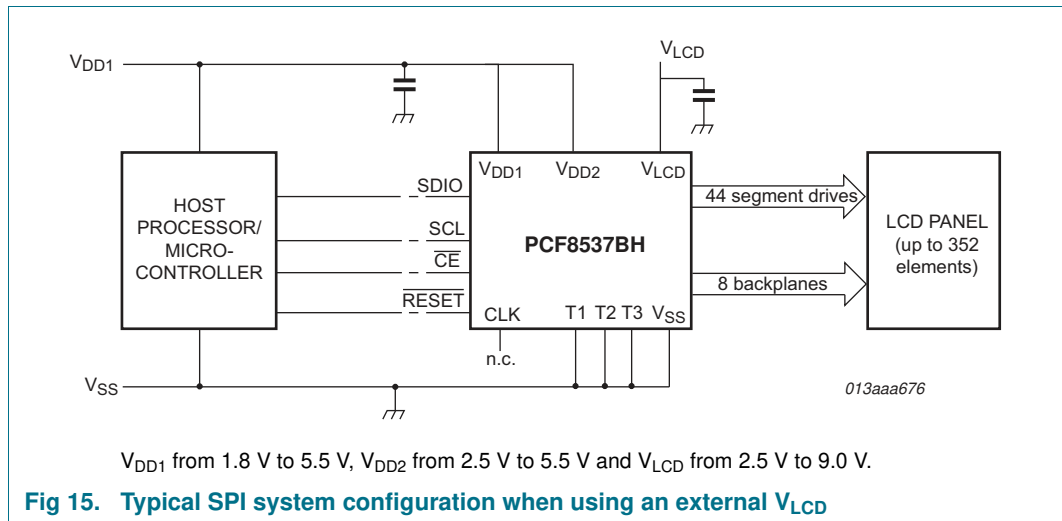
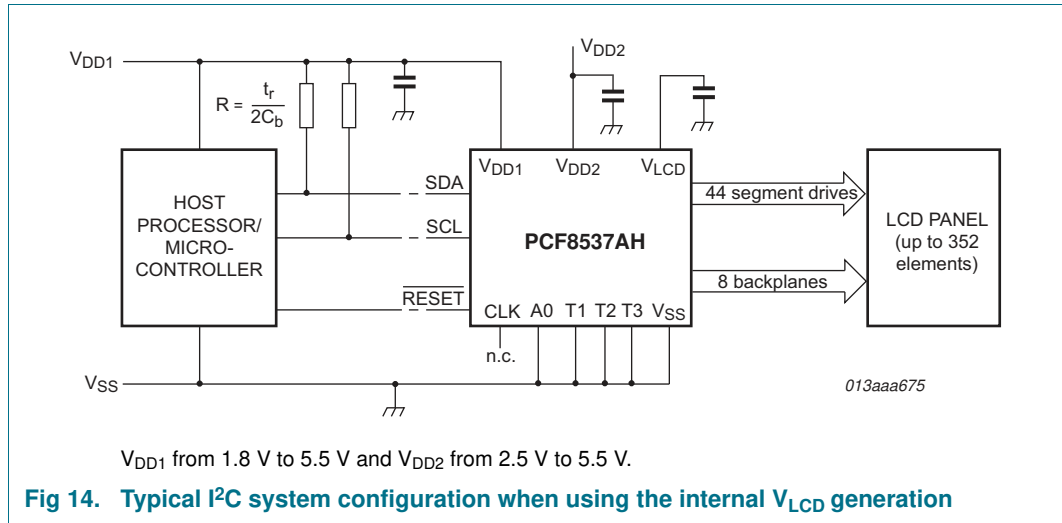

The host microcontroller maintains the two-line I²C-bus communication channel with the PCF8537AH or the three-line SPI-bus with the PCF8537BH. The appropriate biasing voltages for the multiplexed LCD waveforms are generated internally. The only other connections required to complete the system are the power supplies (V_{DD1} , V_{DD2} , V_{SS} , V_{LCD}), the external capacitors, and the LCD panel selected for the application.

The recommended values for external capacitors on V_{DD1} , V_{DD2} , and V_{LCD} are of nominal 100 nF value. When using bigger capacitors, especially on the V_{LCD} , the generated ripple will be consequently smaller. However it will take longer for the internal charge pump to first reach the target V_{LCD} voltage.

If V_{DD1} and V_{DD2} are connected externally, the capacitors on V_{DD1} and V_{DD2} can be replaced by a single capacitor with a nominal value of 220 nF.

Remark: In case of insufficient decoupling, ripple on V_{DD1} and V_{DD2} will create additional V_{LCD} ripple. The ripple on the V_{LCD} can be reduced by making the V_{SS} connection as low-ohmic as possible. Excessive ripple on V_{LCD} may cause flicker on the display.

8.4 LCD supply voltage

8.4.1 External V_{LCD} supply

V_{LCD} can be directly supplied to the VLCD pin. In this case, the internal charge pump must not be enabled otherwise a high current may occur on pin VDD2 and pin VLCD. When V_{LCD} is supplied externally, no internal temperature compensation occurs on this voltage even if bit TCE is set logic 1 (see Section 8.4.4.2). The V_{LCD} voltage which is supplied externally will be available at the segments and backplanes of the device through the chosen bias system. Also programming VPR[7:0] will have no effect on the V_{LCD} which is externally supplied.

8.4.2 Internal V_{LCD} generation

V_{LCD} can be generated and controlled on the chip by using software commands. When the internal charge pump is used, the programmed V_{LCD} is available on pin VLCD. The charge pump generates a V_{LCD} of up to 3 × V_{DD2}. The charge pump can be enabled or disabled with the CPE bit (see Table 8 on page 9). With bit CPC, the charge pump multiplier setting can be configured.

The final value of V_{LCD} is a combination of the programmed V_{prog(LCD)} value and the output of the temperature compensation block, V_{offset(LCD)}.

$$V_{LCD} = V_{prog(LCD)} + V_{offset(LCD)} \tag{1}$$

The system is shown in Figure 16.

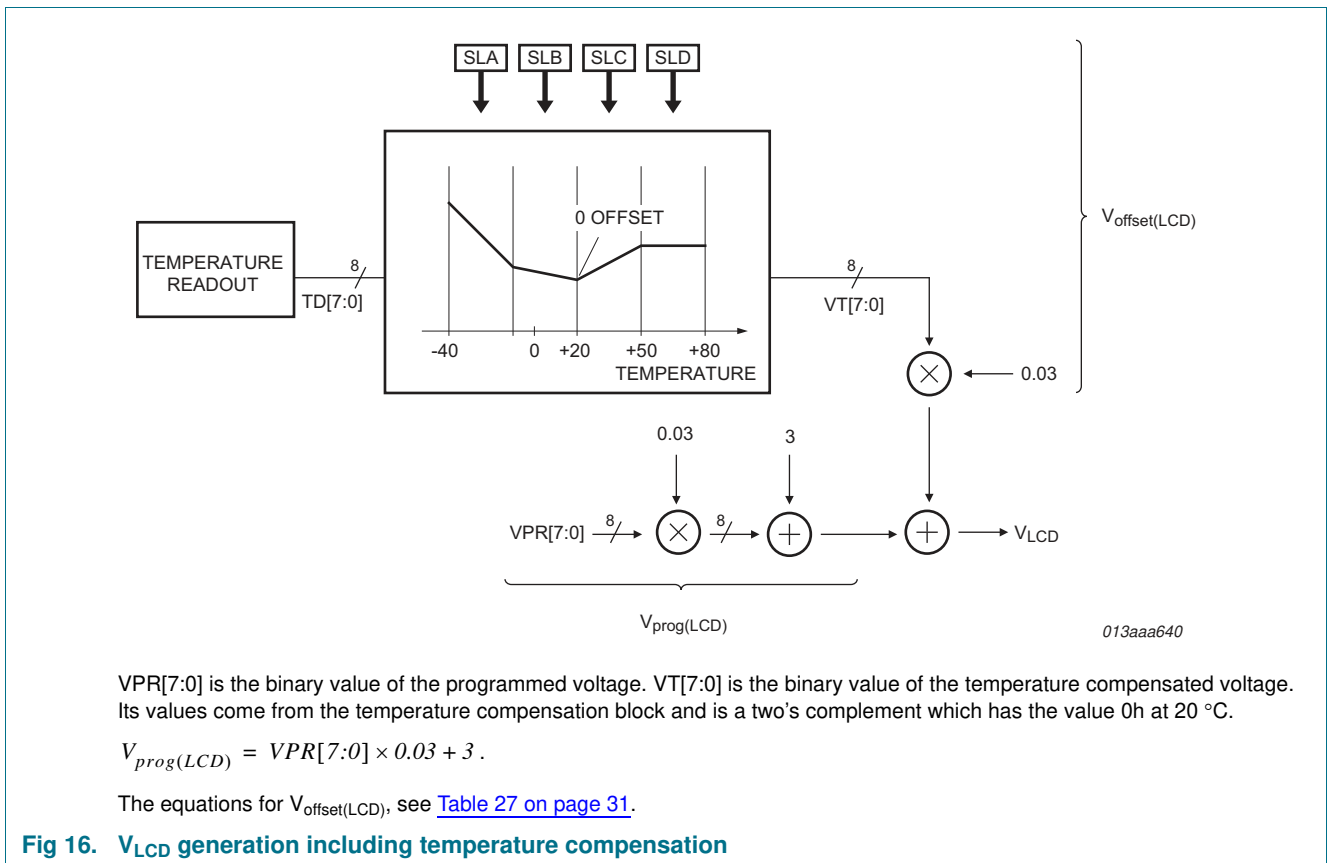
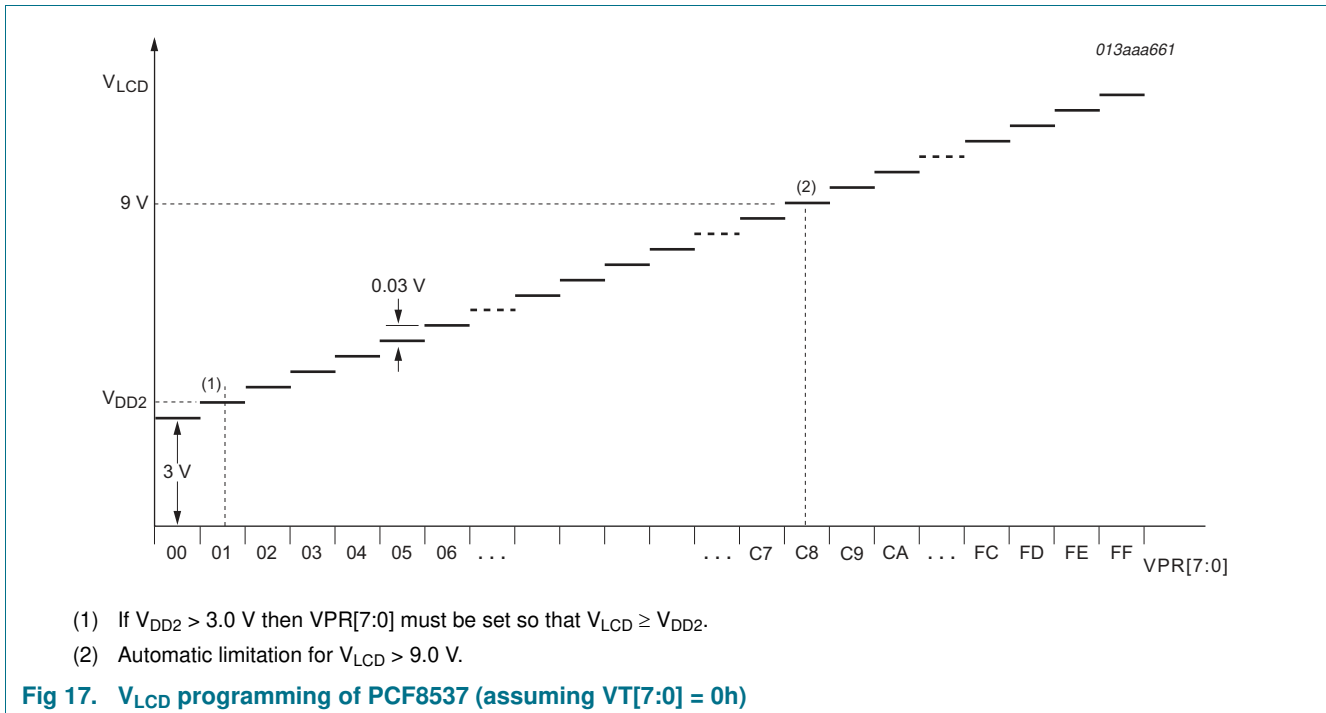

Fig 16. V_{LCD} generation including temperature compensation

Figure 17 illustrates how V_{LCD} changes with the programmed value of $VPR[7:0]$.



The programmable range of $VPR[7:0]$ is from 0h to FFh. With the upper part of the programmable range, it is possible to achieve more than 9.0 V, but the PCF8537 has a built-in automatic limitation of V_{LCD} at 9.0 V. If V_{DD2} is higher than 3.0 V, then it is important that $VPR[7:0]$ is set to a value such that the resultant V_{LCD} (including the temperature correction of $VT[7:0]$) is higher than V_{DD2} .

8.4.3 Charge pump

8.4.3.1 Charge pump configuration

To obtain the desired V_{LCD} values, the charge pump has to be configured properly. It has to be taken into account that the maximum theoretical values cannot be reached due to internal losses (see Section 8.4.3.2). So, for example, it is not possible to get a $V_{LCD} = 6.0$ V with $V_{DD2} = 3.0$ V and a charge pump configuration of 2 times V_{DD2} . In this case, a charge pump configuration of 3 times V_{DD2} is needed.

8.4.3.2 Charge pump driving capability

Figure 18 and Figure 19 are showing the charge pump driving capability with different settings of V_{DD2} and charge pump configurations.

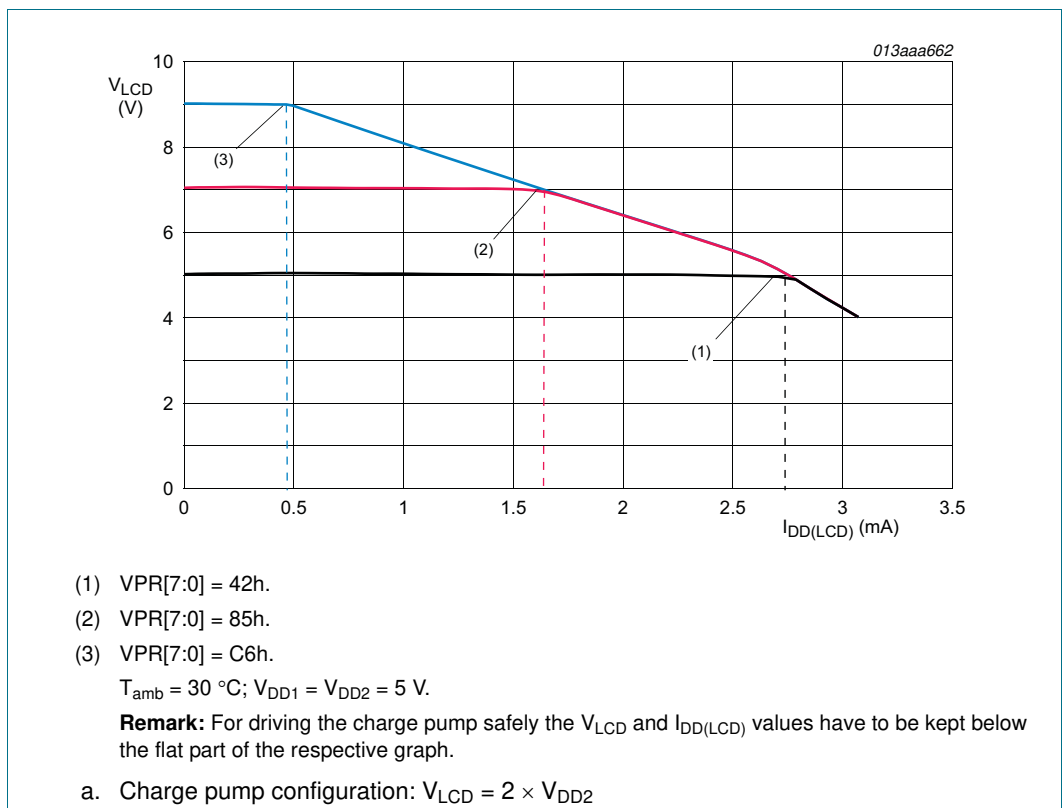
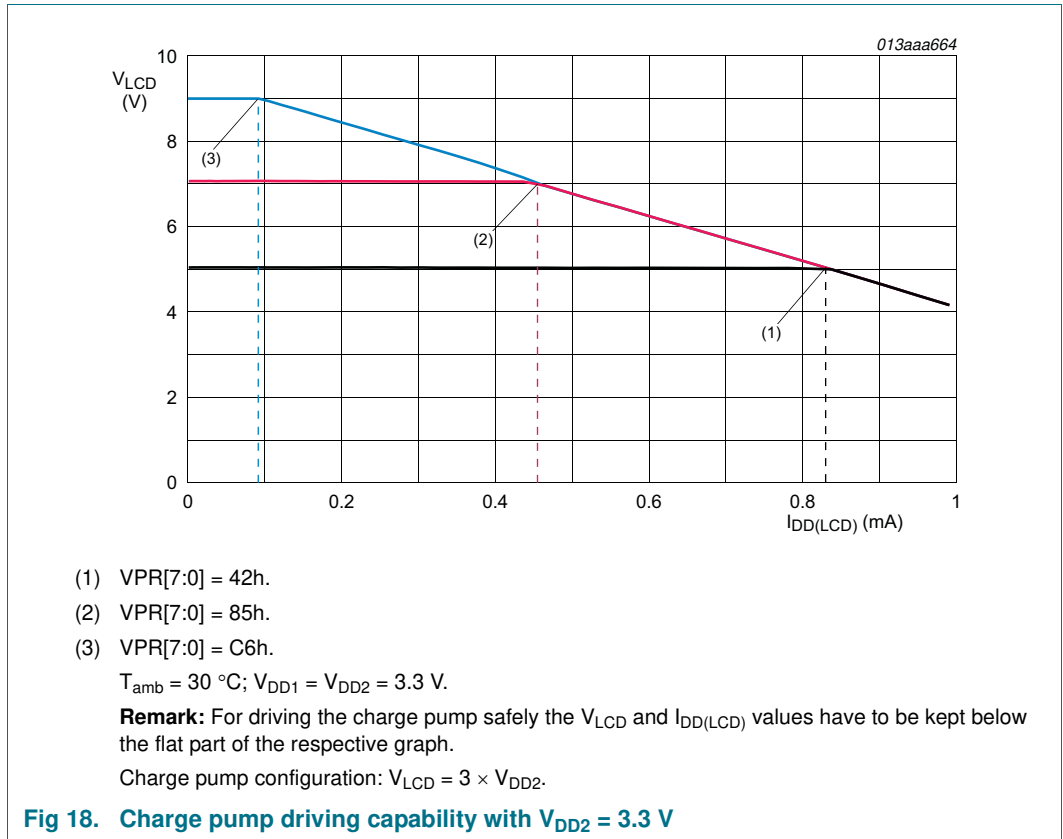

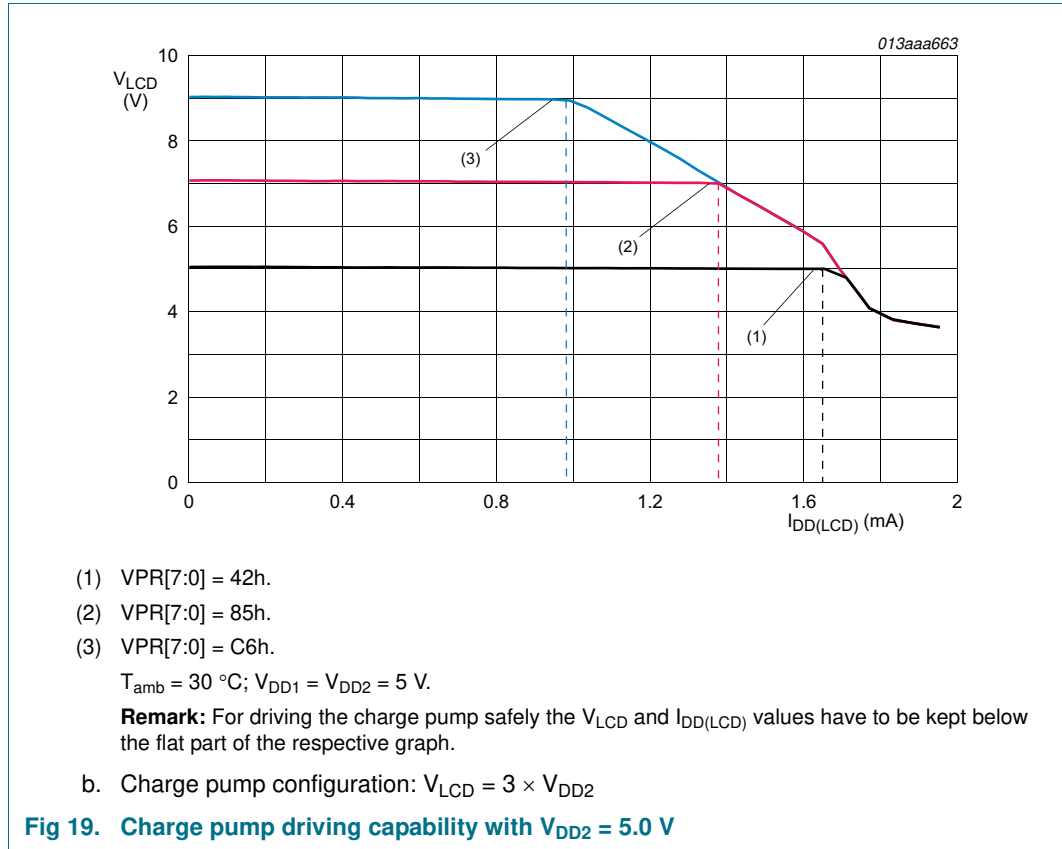

8.4.4 Temperature measurement and temperature compensation of V_{LCD}

8.4.4.1 Temperature readout

The PCF8537 has a built-in temperature sensor which provides an 8 bit digital value, TD[7:0], of the ambient temperature. This value can be read through the interface (see [Figure 47 on page 56](#) and [Figure 51 on page 59](#)). The actual temperature is determined from TD[7:0] using [Equation 2](#):

$$T (^{\circ}C) = 0.9375 \times TD[7:0] - 40 \tag{2}$$

The measurement needs about 5 ms to complete and is repeated periodically as soon as bit TME is set logic 1 (see [Table 9 on page 10](#)). The time between measurements is linked to the system clock and hence varies with changes in the chosen frame frequency, see [Table 25](#).

Table 25. Temperature measurement update rate

Selected frame frequency	Temperature measurement update rate
60 Hz	3.3 s
200 Hz	1 s
300 Hz	0.67 s

The temperature sensor can be thought of as analog to digital converter. Like all A/D converters, jitter will exist on the LSB of the output value. This is also true of the temperature sensor in the PCF8537. Jitter of the LSB of TD[7:0] may lead to contrast

stepping of the display due to the V_{LCD} voltage is periodically changing between two different target voltages. For this reason, a filter has been implemented to ensure that LSB jitter does not affect the display performance.

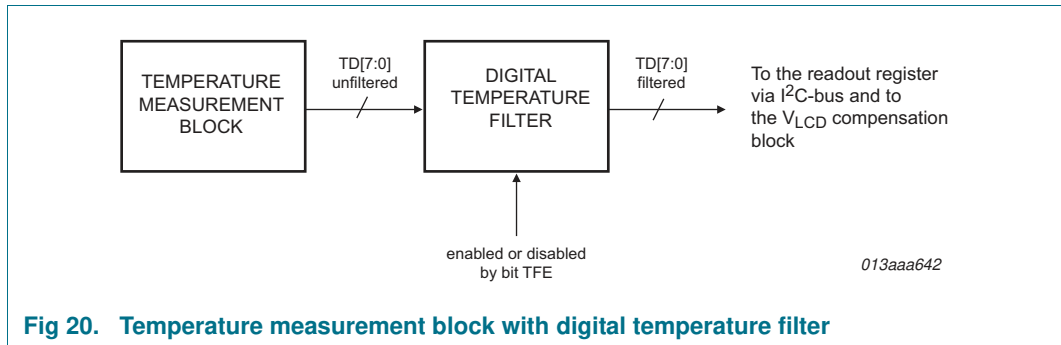

Fig 20. Temperature measurement block with digital temperature filter

Like any other filtering, the digital temperature filter (see Figure 20) introduces a certain delay in the measurement of temperature. This behavior is illustrated in Figure 21.

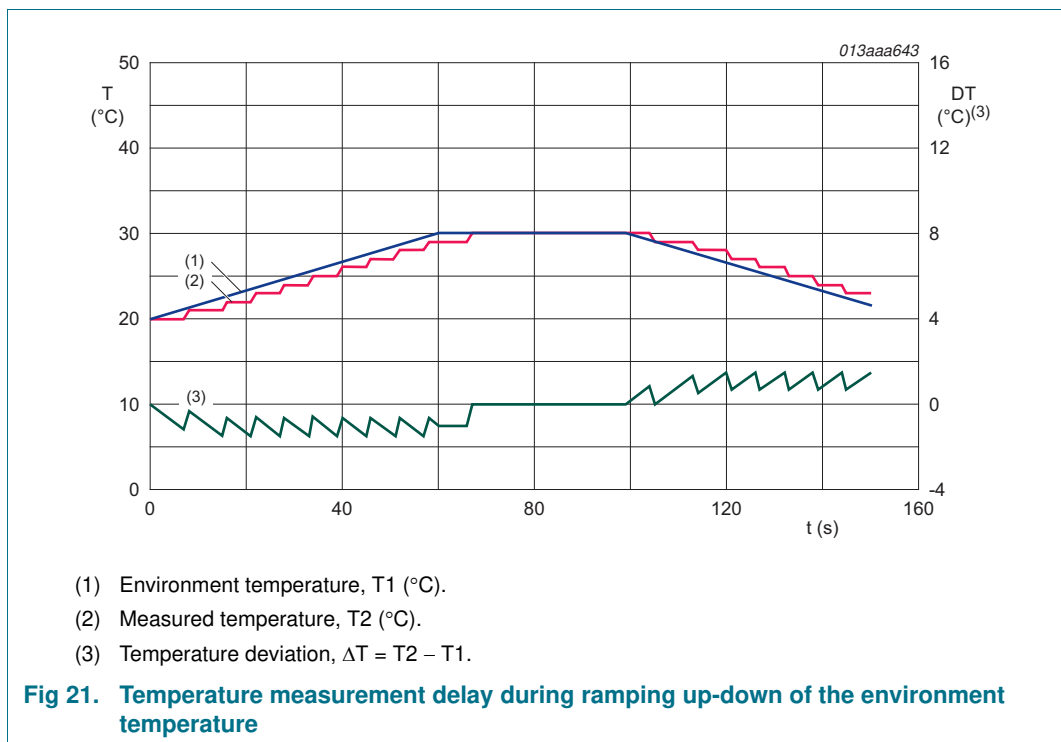

Fig 21. Temperature measurement delay during ramping up-down of the environment temperature

This delay may cause undesired effects at start-up when the environment temperature may be different than the reset value of the PCF8537 which is 20 °C. In this case, it takes up to 30 s until the correct measured temperature value will be available. A control bit, TFE (see Table 22 on page 16), is implemented to enable or disable the digital temperature filter. This bit is set logic 0 by default, which means, that the filter is disabled and the unfiltered environment temperature value is available to calculate the desired V_{LCD} .

8.4.4.2 Temperature adjustment of the V_{LCD}

Due to the temperature dependency of the liquid crystal viscosity the LCD controlling voltage V_{LCD} might have to be adjusted at different temperatures to maintain optimal contrast. The temperature behavior of the liquid comes from the LCD manufacturer. The slope has to be set to compensate for the liquid behavior. Internal temperature compensation may be enabled via bit TCE (see [Table 9 on page 10](#)).

The ambient temperature range is split up into four equally sized regions and a different temperature coefficient can be applied to each. Each coefficient can be selected from a choice of eight different slopes. Each one of these coefficients may be independently selected (see [Table 26](#)).

Table 26. Temperature coefficients

SLA to SLD register value	Corresponding slope factor, SFA to SFD (mV/°C)
000 ^[1]	0
001	-4
010	-8
011	-16
100	-40
101	+4
110	+8
111	+16

[1] Default value.

The slope factors imply a linear correction, however the implementation is in steps of 30 mV.

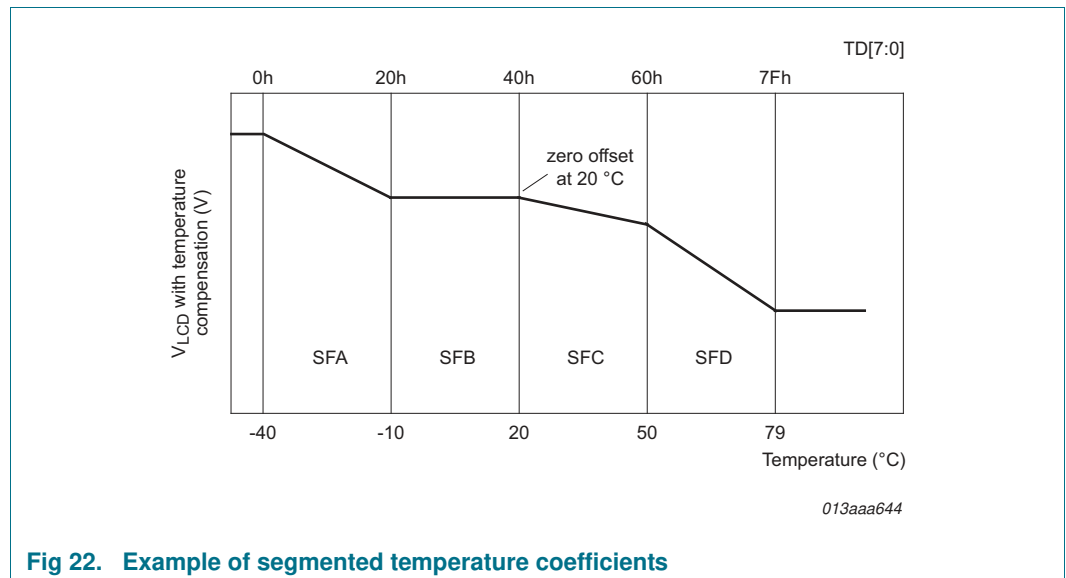

Fig 22. Example of segmented temperature coefficients

The offset voltage is calculated according to [Table 27](#).

Table 27. Calculation of the V_{LCD} offset voltage

Temperature range	$V_{offset(LCD)}$ voltage (mV)
$T \leq -40\text{ °C}$	$V_{offset(LCD)} = 30 \times SFA + 30 \times SFB$
$-40\text{ °C} \leq T \leq -10\text{ °C}$	$V_{offset(LCD)} = (-10 - T) \times SFA + 30 \times SFB$
$-10\text{ °C} < T \leq 20\text{ °C}$	$V_{offset(LCD)} = (20 - T) \times SFB$
$20\text{ °C} < T \leq 50\text{ °C}$	$V_{offset(LCD)} = (T - 20) \times SFC$
$50\text{ °C} < T < 80\text{ °C}$	$V_{offset(LCD)} = (T - 50) \times SFD + 30 \times SFC$
$80\text{ °C} \leq T$ ^[1]	$V_{offset(LCD)} = 30 \times SFD + 30 \times SFC$

[1] No temperature compensation is possible above 80 °C. Above this value, the system maintains the compensation value from 80 °C.

Example: Assumed that $T_{amb} = -8\text{ °C}$; $SFB = -16\text{ mV/°C}$:

$$V_{offset(LCD)} = (20 - -8) \times (-16) = 28 \times (-16) = -448\text{ mV}$$

Remark: Care must be taken that the ranges of VPR[7:0] and VT[7:0] do not cause clipping and hence undesired results. The device will not permit overflow or underflow and will clamp results to either end of the range.

8.4.5 LCD voltage selector

The LCD voltage selector co-ordinates the multiplexing of the LCD in accordance with the selected LCD drive configuration. The operation of the voltage selector is controlled by the Set-bias-mode command (see [Table 14 on page 12](#)) and the Set-MUX-mode command (see [Table 13 on page 12](#)).

Intermediate LCD biasing voltages are obtained from an internal voltage divider. The biasing configurations that apply to the preferred modes of operation, together with the biasing characteristics as functions of V_{LCD} and the resulting discrimination ratios (D), are given in [Table 28](#).

Discrimination is a term which is defined as the ratio of the one and off RMS voltage across a segment. It can be thought of as a measurement of contrast.

Table 28. LCD drive modes: summary of characteristics

LCD drive mode	Number of:		LCD bias configuration	$\frac{V_{off(RMS)}}{V_{LCD}}$	$\frac{V_{on(RMS)}}{V_{LCD}}$	$D = \frac{V_{on(RMS)}}{V_{off(RMS)}} [1]$	$V_{LCD} [2]$
	Backplanes	Bias levels					
static	1	2	static	0	1	∞	$V_{on(RMS)}$
1:2 multiplex	2	3	$\frac{1}{2}$	0.354	0.791	2.236	$2.828V_{off(RMS)}$
1:2 multiplex	2	4	$\frac{1}{3}$	0.333	0.745	2.236	$3.0V_{off(RMS)}$
1:2 multiplex [3]	2	5	$\frac{1}{4}$	0.395	0.729	1.845	$2.529V_{off(RMS)}$
1:4 multiplex [3]	4	3	$\frac{1}{2}$	0.433	0.661	1.527	$2.309V_{off(RMS)}$
1:4 multiplex	4	4	$\frac{1}{3}$	0.333	0.577	1.732	$3.0V_{off(RMS)}$
1:4 multiplex [3]	4	5	$\frac{1}{4}$	0.331	0.545	1.646	$3.024V_{off(RMS)}$
1:6 multiplex [3]	6	3	$\frac{1}{2}$	0.456	0.612	1.341	$2.191V_{off(RMS)}$
1:6 multiplex	6	4	$\frac{1}{3}$	0.333	0.509	1.527	$3.0V_{off(RMS)}$
1:6 multiplex	6	5	$\frac{1}{4}$	0.306	0.467	1.527	$3.266V_{off(RMS)}$
1:8 multiplex [3]	8	3	$\frac{1}{2}$	0.467	0.586	1.254	$2.138V_{off(RMS)}$
1:8 multiplex [3]	8	4	$\frac{1}{3}$	0.333	0.471	1.414	$3.0V_{off(RMS)}$
1:8 multiplex	8	5	$\frac{1}{4}$	0.293	0.424	1.447	$3.411V_{off(RMS)}$

[1] Determined from Equation 5.

[2] Determined from Equation 4.

[3] In these examples, the discrimination factor and hence the contrast ratios are smaller. The advantage of these LCD drive modes is a power saving from a reduction of the LCD voltage V_{LCD} .

A practical value for V_{LCD} is determined by equating $V_{off(RMS)}$ with a defined LCD threshold voltage (V_{th}), typically when the LCD exhibits approximately 10 % contrast. In the static drive mode, a suitable choice is $V_{LCD} > 3V_{th}$.

Bias is calculated by $\frac{1}{1+a}$, where the values for a are

$a = 1$ for $\frac{1}{2}$ bias

$a = 2$ for $\frac{1}{3}$ bias

$a = 3$ for $\frac{1}{4}$ bias

The RMS on-state voltage ($V_{on(RMS)}$) for the LCD is calculated with Equation 3

$$V_{on(RMS)} = V_{LCD} \sqrt{\frac{a^2 + 2a + n}{n \times (1 + a)^2}} \tag{3}$$

where V_{LCD} is the resultant voltage at the LCD segment and where the values for n are

$n = 1$ for static mode

$n = 2$ for 1:2 multiplex

$n = 4$ for 1:4 multiplex

$n = 6$ for 1:6 multiplex

$n = 8$ for 1:8 multiplex

The RMS off-state voltage ($V_{off(RMS)}$) for the LCD is calculated with Equation 4:

$$V_{off(RMS)} = V_{LCD} \sqrt{\frac{a^2 - 2a + n}{n \times (1 + a)^2}} \tag{4}$$

Discrimination is the ratio of $V_{on(RMS)}$ to $V_{off(RMS)}$ and is determined from [Equation 5](#):

$$\frac{V_{on(RMS)}}{V_{off(RMS)}} = \sqrt{\frac{(a + 1)^2 + (n - 1)}{(a - 1)^2 + (n - 1)}} \tag{5}$$

It should be noted that V_{LCD} is sometimes referred as the LCD operating voltage.

8.4.5.1 Electro-optical performance

Suitable values for $V_{on(RMS)}$ and $V_{off(RMS)}$ are dependent on the LCD liquid used. The RMS voltage, at which a pixel will be switched on or off, determine the transmissibility of the pixel.

For any given liquid, there are two threshold values defined. One point is at 10 % relative transmission (at $V_{th(off)}$) and the other at 90 % relative transmission (at $V_{th(on)}$), see [Figure 23](#). For a good contrast performance, the following rules should be followed:

$$V_{on(RMS)} \geq V_{th(on)} \tag{6}$$

$$V_{off(RMS)} \leq V_{th(off)} \tag{7}$$

$V_{on(RMS)}$ and $V_{off(RMS)}$ are properties of the display driver and are affected by the selection of a (see [Equation 3](#)), n (see [Equation 5](#)), and the V_{LCD} voltage.

$V_{th(off)}$ and $V_{th(on)}$ are properties of the LCD liquid and can be provided by the module manufacturer. $V_{th(off)}$ is sometimes just named V_{th} . $V_{th(on)}$ is sometimes named saturation voltage V_{sat} .

It is important to match the module properties to those of the driver in order to achieve optimum performance.

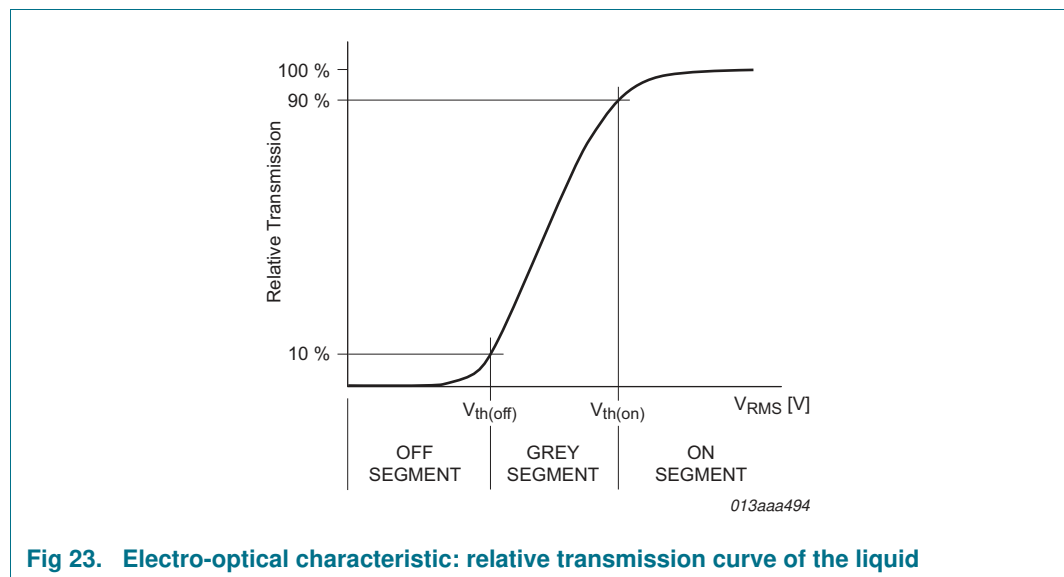
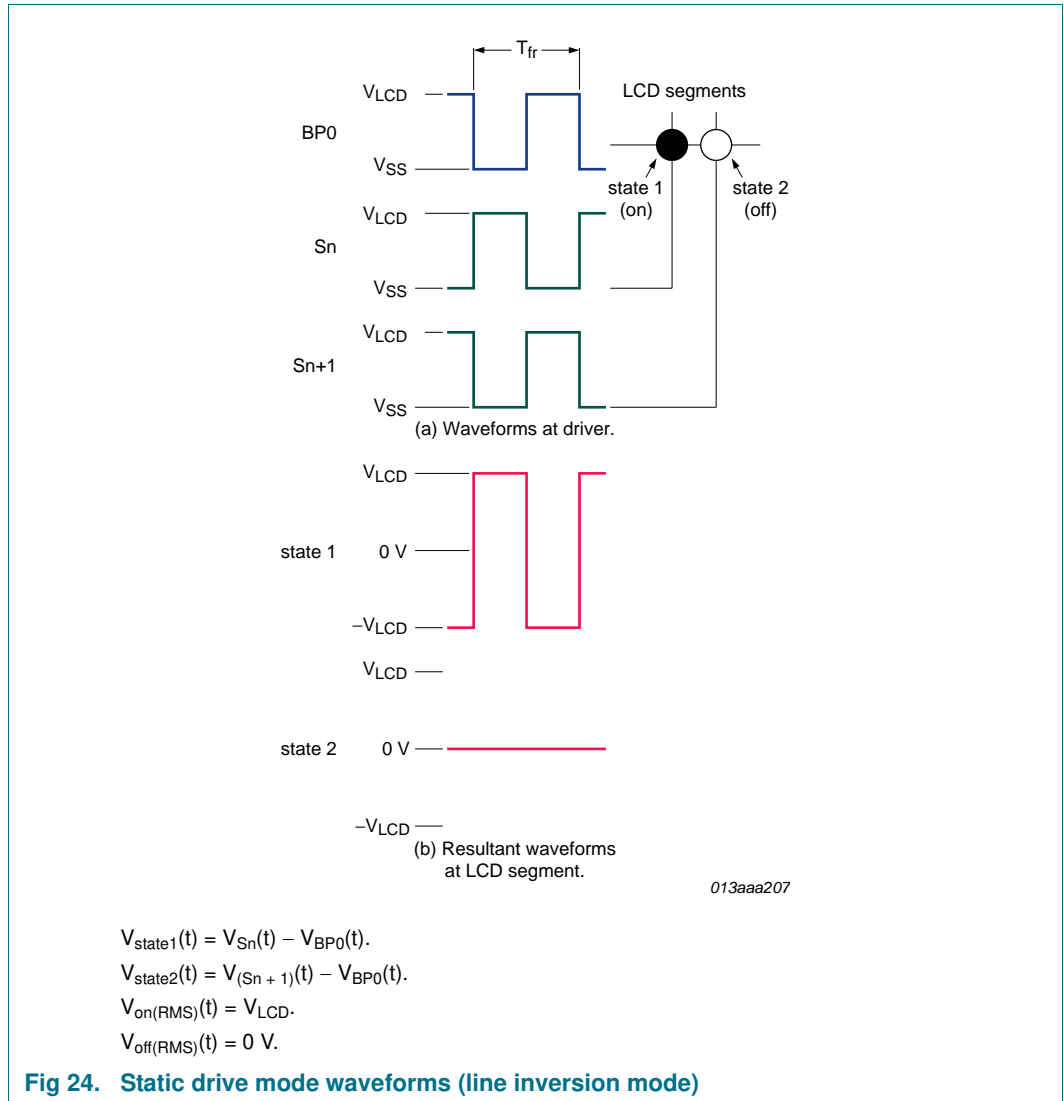

Fig 23. Electro-optical characteristic: relative transmission curve of the liquid

8.4.6 LCD drive mode waveforms

8.4.6.1 Static drive mode

The static LCD drive mode is used when a single backplane is provided in the LCD.



8.4.6.2 1:2 multiplex drive mode

When two backplanes are provided in the LCD, the 1:2 multiplex mode applies. The PCF8537 allows the use of 1/2 bias or 1/3 bias in this mode as shown in [Figure 25](#) and [Figure 26](#).

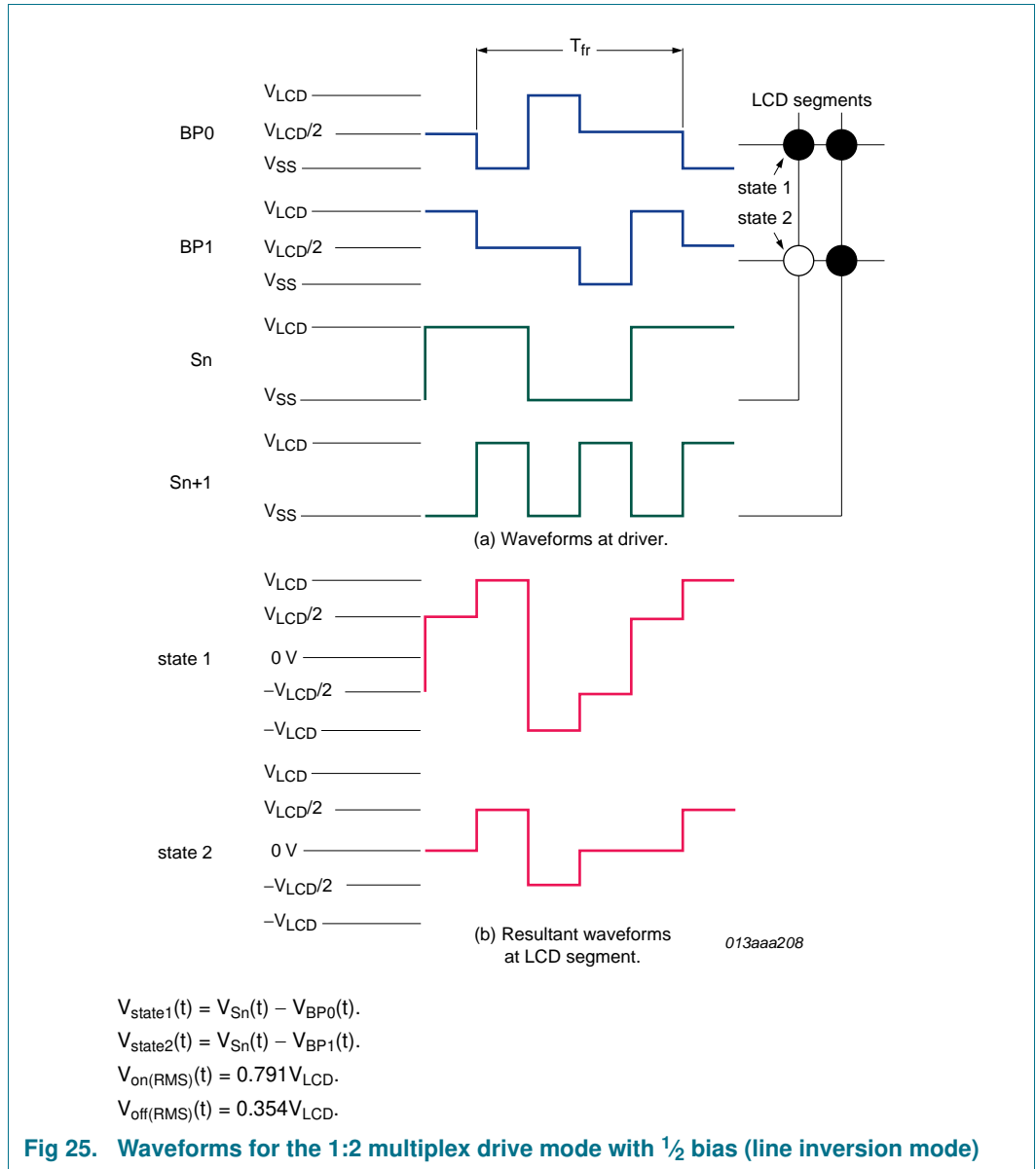

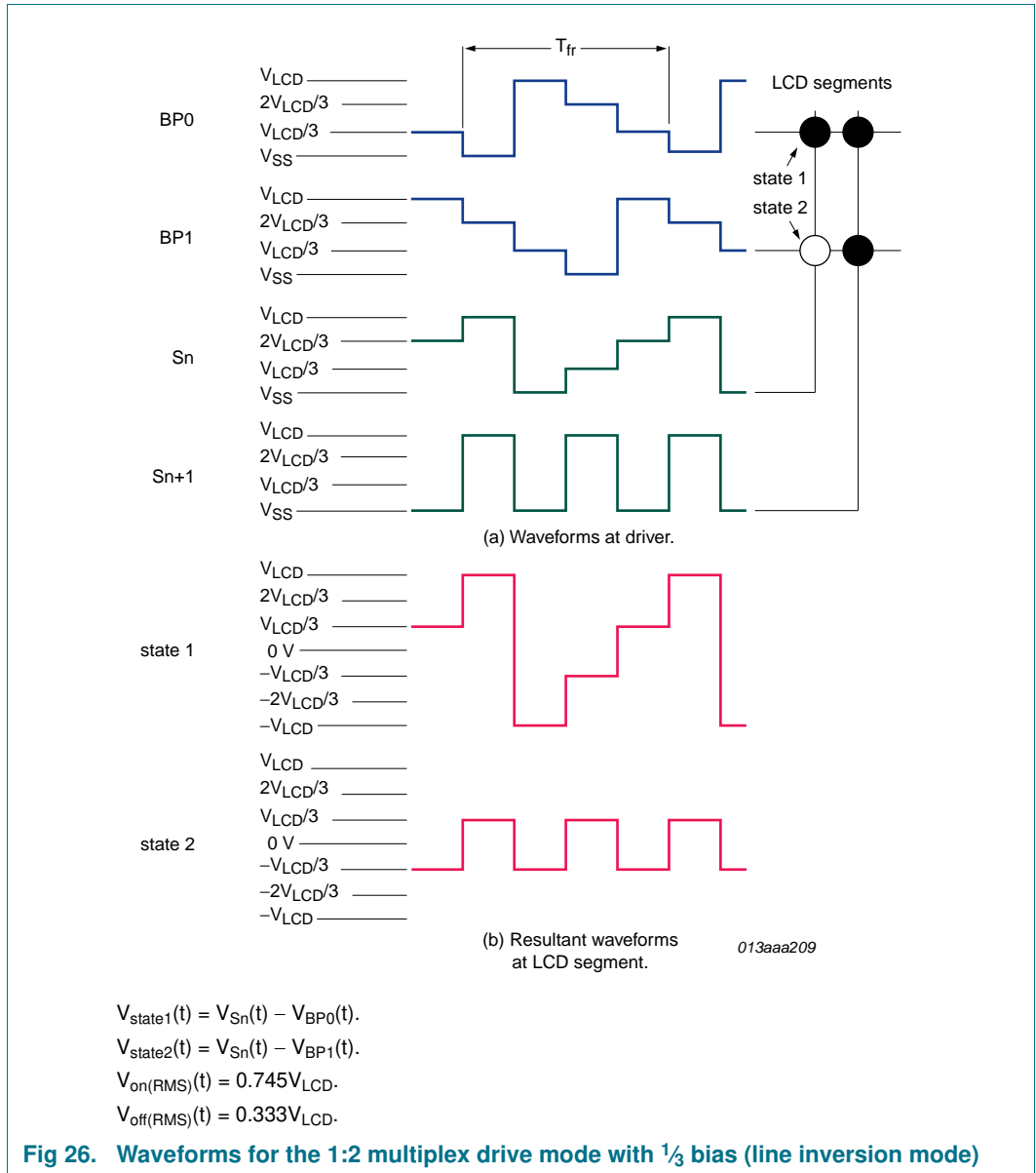

8.4.6.3 1:4 multiplex drive mode

When four backplanes are provided in the LCD, the 1:4 multiplex drive mode applies, as shown in Figure 27.

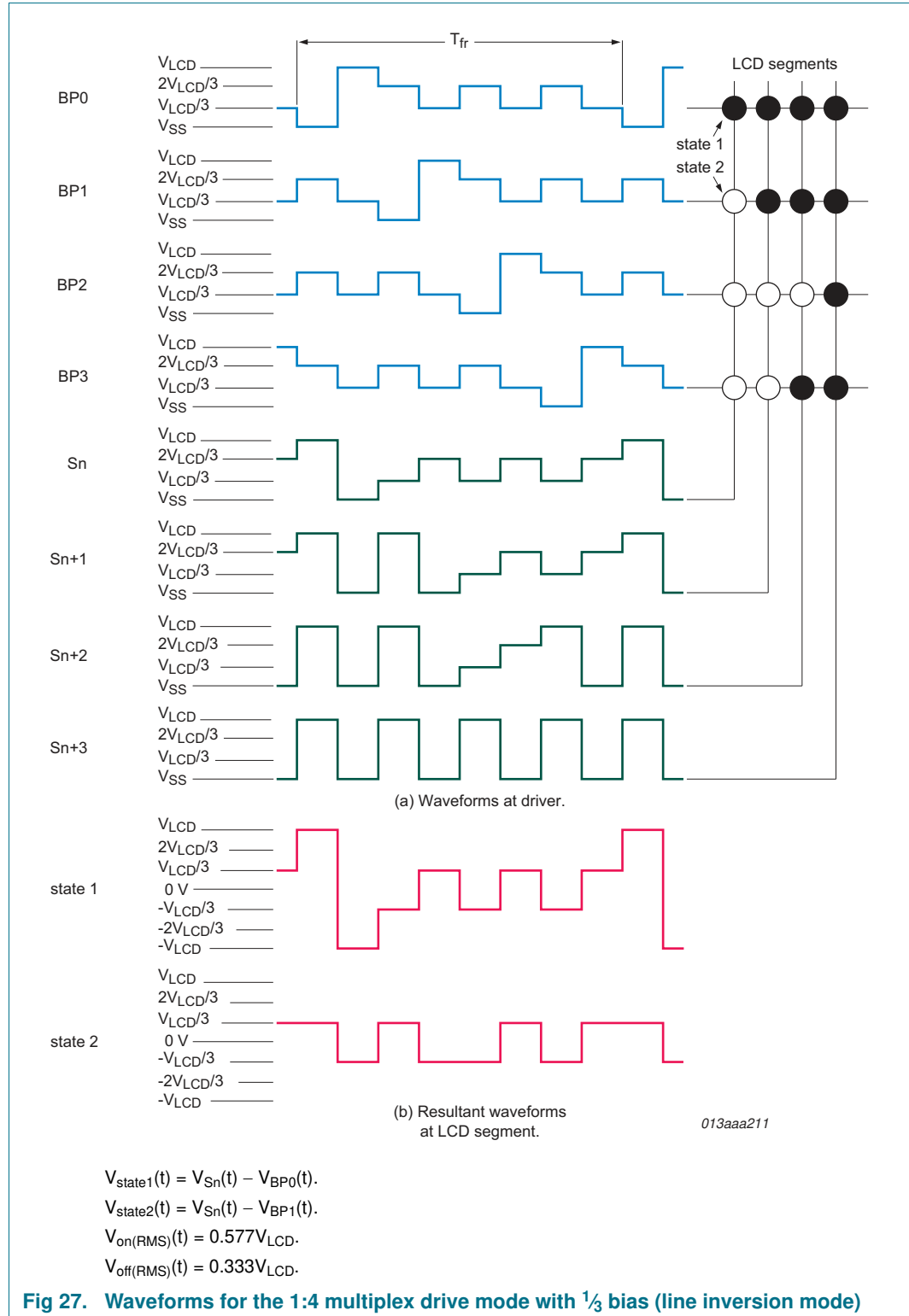

8.4.6.4 1:6 multiplex drive mode

When six backplanes are provided in the LCD, the 1:6 multiplex drive mode applies. The PCF8537 allows the use of $\frac{1}{3}$ bias or $\frac{1}{4}$ bias in this mode as shown in [Figure 28](#) and [Figure 29](#).

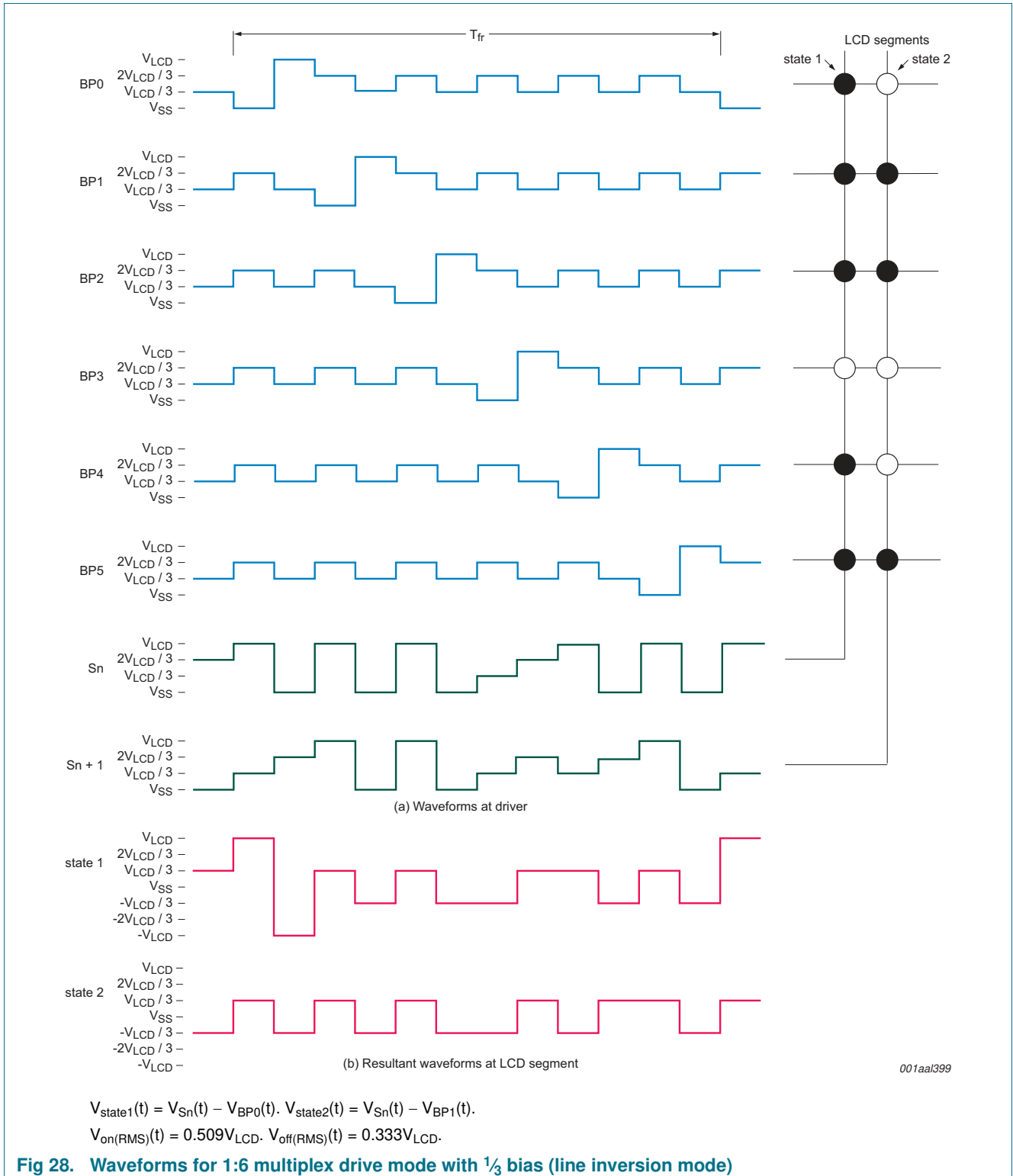

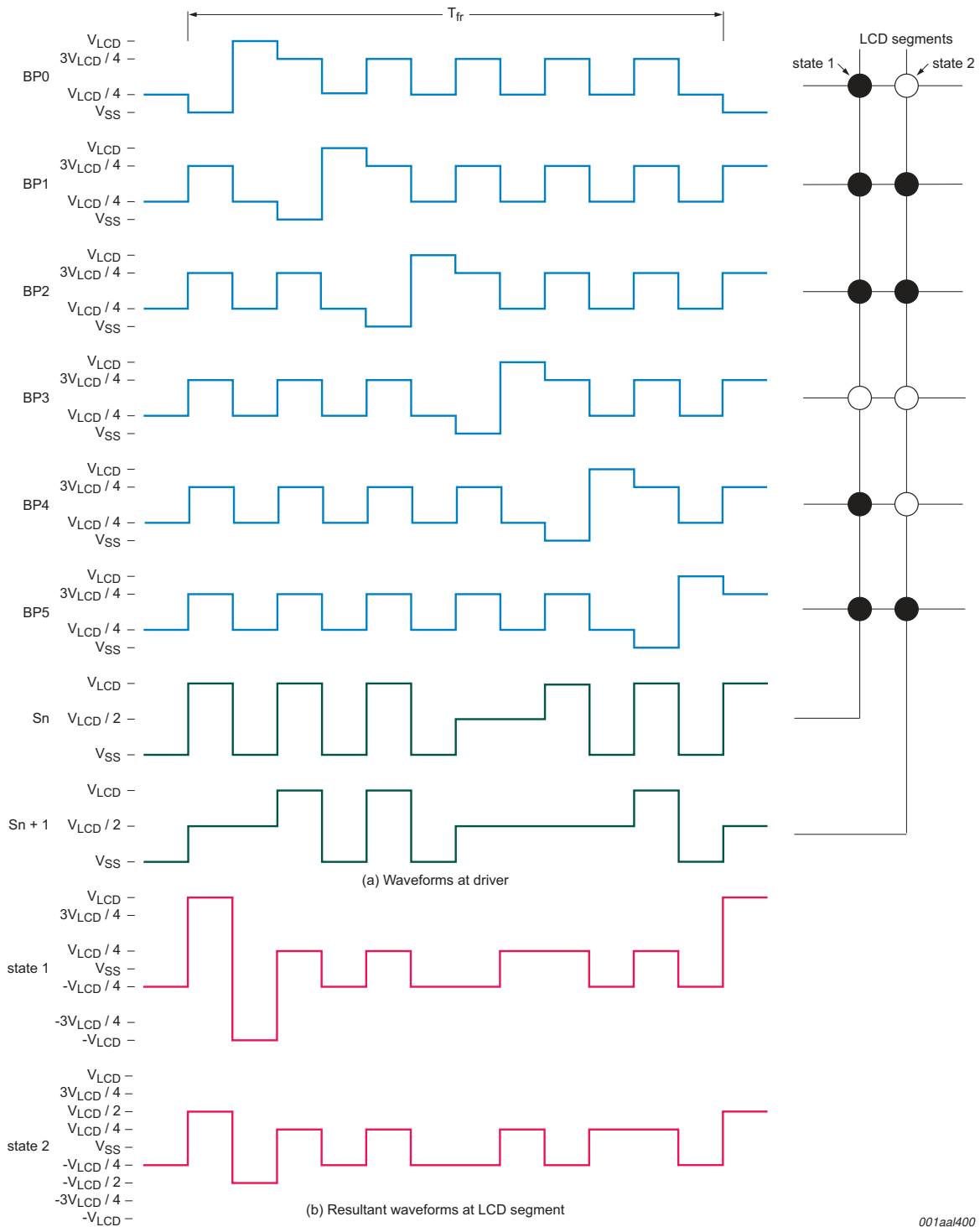

$$V_{state1}(t) = V_{Sn}(t) - V_{BP0}(t). \quad V_{state2}(t) = V_{Sn}(t) - V_{BP1}(t).$$

$$V_{on(RMS)}(t) = 0.467V_{LCD}. \quad V_{off(RMS)}(t) = 0.306V_{LCD}.$$

Fig 29. Waveforms for 1:6 multiplex drive mode with 1/4 bias (line inversion mode)

001aa1400

8.4.6.5 1:8 multiplex drive mode

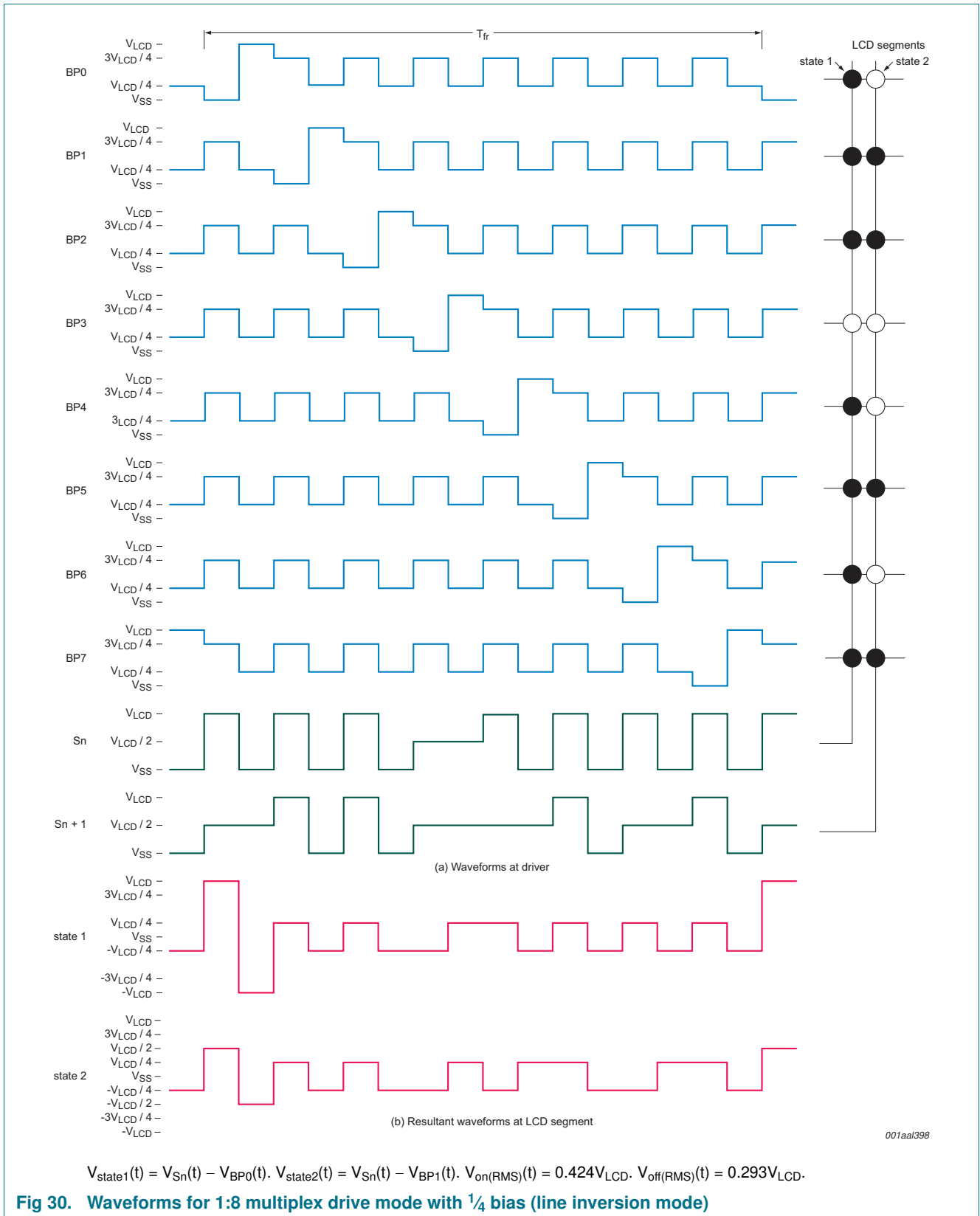
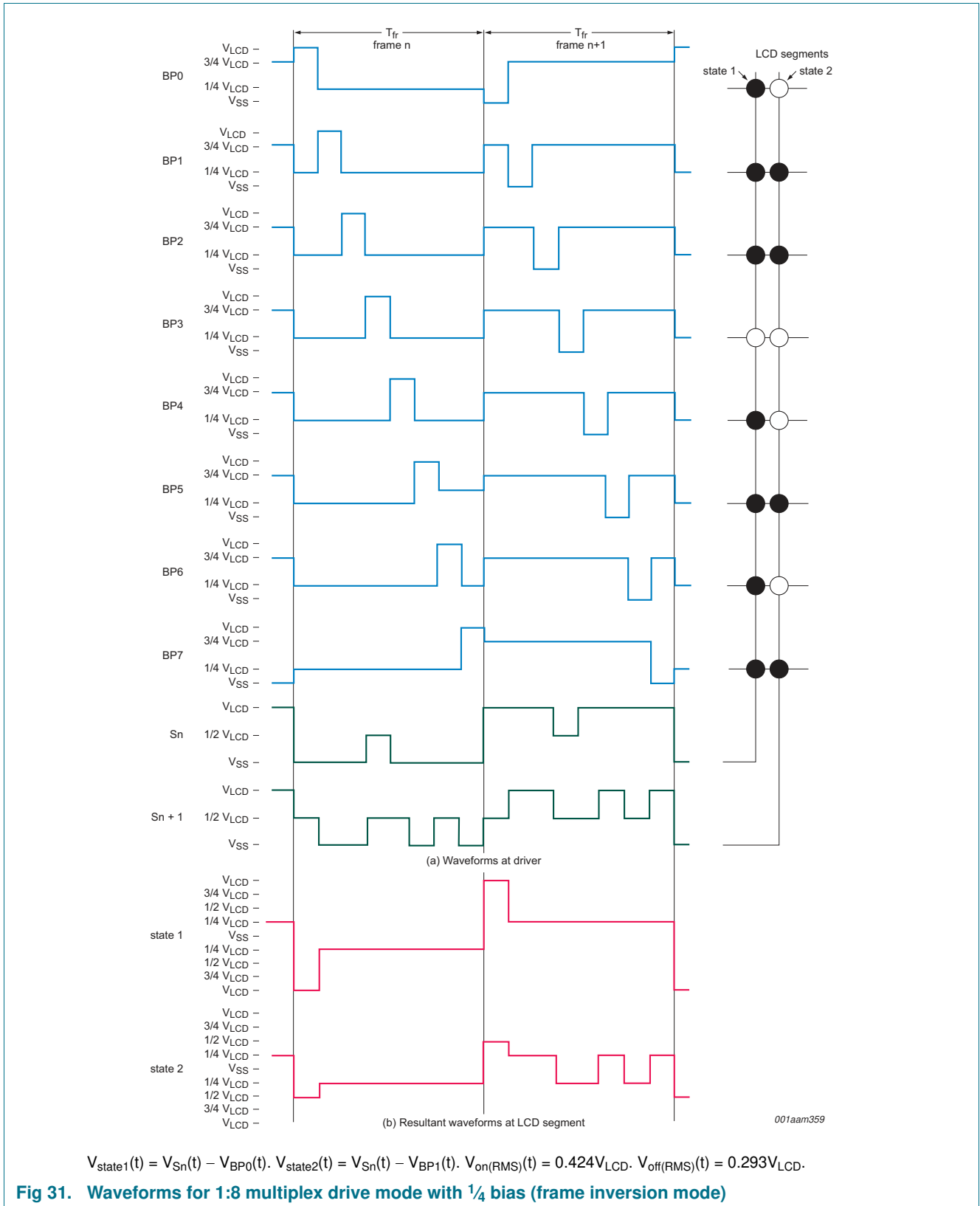

Fig 30. Waveforms for 1:8 multiplex drive mode with 1/4 bias (line inversion mode)



8.5 Backplane and segment outputs

8.5.1 Backplane outputs

The LCD drive section includes eight backplane outputs: BP0 to BP7. The backplane output signals are generated based on the selected LCD multiplex drive mode.

[Table 29](#) describes which outputs are active for each of the multiplex drive modes and what signal is generated.

Table 29. Mapping of output pins and corresponding signals with respect to driving mode

MUX mode	Output pin							
	BP0	BP1	BP2	BP3	BP4	BP5	S45/BP6	S44/BP7
	Signal							
1:8	BP0	BP1	BP2	BP3	BP4	BP5	BP6	BP7
1:6	BP0	BP1	BP2	BP3	BP4	BP5	S45	S44
1:4	BP0	BP1	BP2	BP3	BP0 ^[1]	BP1 ^[1]	BP2 ^[1]	BP3 ^[1]
1:2	BP0	BP1	BP0 ^[1]	BP1 ^[1]	BP0 ^[1]	BP1 ^[1]	BP0 ^[1]	BP1 ^[1]
static	BP0	BP0 ^[1]	BP0 ^[1]	BP0 ^[1]	BP0 ^[1]	BP0 ^[1]	BP0 ^[1]	BP0 ^[1]

[1] These pins may optionally or alternatively be connected to the display to improve drive strength. Connect only with the corresponding output pin carrying the same signal. If not required, they can be left open circuit.

8.5.1.1 1:8 multiplex drive mode

In 1:8 multiplex drive mode, BP0 to BP7 must be connected directly to the LCD.

8.5.1.2 1:6 multiplex drive mode

1:6 multiplex mode is a special case. In this mode BP0 to BP5 must be connected directly to the display as back plane signals and S44 and S45 must be connected to the display as segment signals.

8.5.1.3 1:4 multiplex drive mode

In the 1:4 multiplex drive mode, BP0 to BP3 must be connected directly to the LCD.

The unused BPs may be left open-circuit. Optionally they may also be connected to the display to increase drive strength.

- BP0 is repeated on BP4
- BP1 is repeated on BP5
- BP2 is repeated on BP6
- BP3 is repeated on BP7

8.5.1.4 1:2 multiplex drive mode

In the 1:2 multiplex drive mode, BP0 and BP1 must be connected directly to the LCD.

The unused BPs may be left open-circuit. Optionally they may also be connected to the display to increase drive strength.

- BP0 is repeated on BP2, BP4, and BP6
- BP1 is repeated on BP3, BP5, and BP7

8.5.1.5 Static drive mode

In the static drive mode, BP0 must be connected directly to the LCD.

In the static drive mode, the same signal is carried by all eight backplane outputs and they can be connected in parallel for very high drive requirements.

- BP0 is repeated on BP1, BP2, BP3, BP4, BP5, BP6, and BP7

8.5.2 Segment outputs

The LCD drive section includes up to 46 segment outputs. Segments S0 to S43 are always segment outputs. There are also two more segment outputs which become active in 1:6 multiplex mode. These are S45/BP6 and S44/BP7 and must also be connected directly to the display.

The segment output signals are generated based on the multiplexed backplane signals and with data resident in the display register. When less than 46 segment outputs are required, the unused segment outputs must be left open-circuit.

8.5.2.1 Static, 1:8, 1:4, 1:2 multiplex drive mode

In these drive modes, segments S0 to S43 must be connected to the display.

8.5.2.2 1:6 multiplex drive mode

In this drive mode, segments S0 to S43, S44, and S45 must be connected to the display.

8.6 Display controller

The display controller executes the commands identified by the command decoder. It contains the status registers of the PCF8537 and co-ordinates their effects. The controller is also responsible for loading display data into the display RAM as required by the filling order.

8.7 Display register

The display register holds the display data while the corresponding multiplex signals are generated.

8.8 Display RAM

The display RAM stores LCD data. Depending on the multiplex drive mode, the arrangement of the RAM is changed.

- multiplex drive mode 1:8: RAM is 44×8 bit
- multiplex drive mode 1:6: RAM is 46×6 bit
- multiplex drive mode 1:4: RAM is 44×4 bit arranged in two banks
- multiplex drive mode 1:2: RAM is 44×2 bit arranged in two banks
- static drive mode: RAM is 44×1 bit arranged in two banks

A logic 1 in the RAM bit map indicates the on-state of the corresponding LCD element; similarly, a logic 0 indicates the off-state.

There is a one-to-one correspondence between

- the bits in the RAM bitmap and the LCD elements,
- the RAM columns and the segment outputs,
- the RAM rows and the backplane outputs.

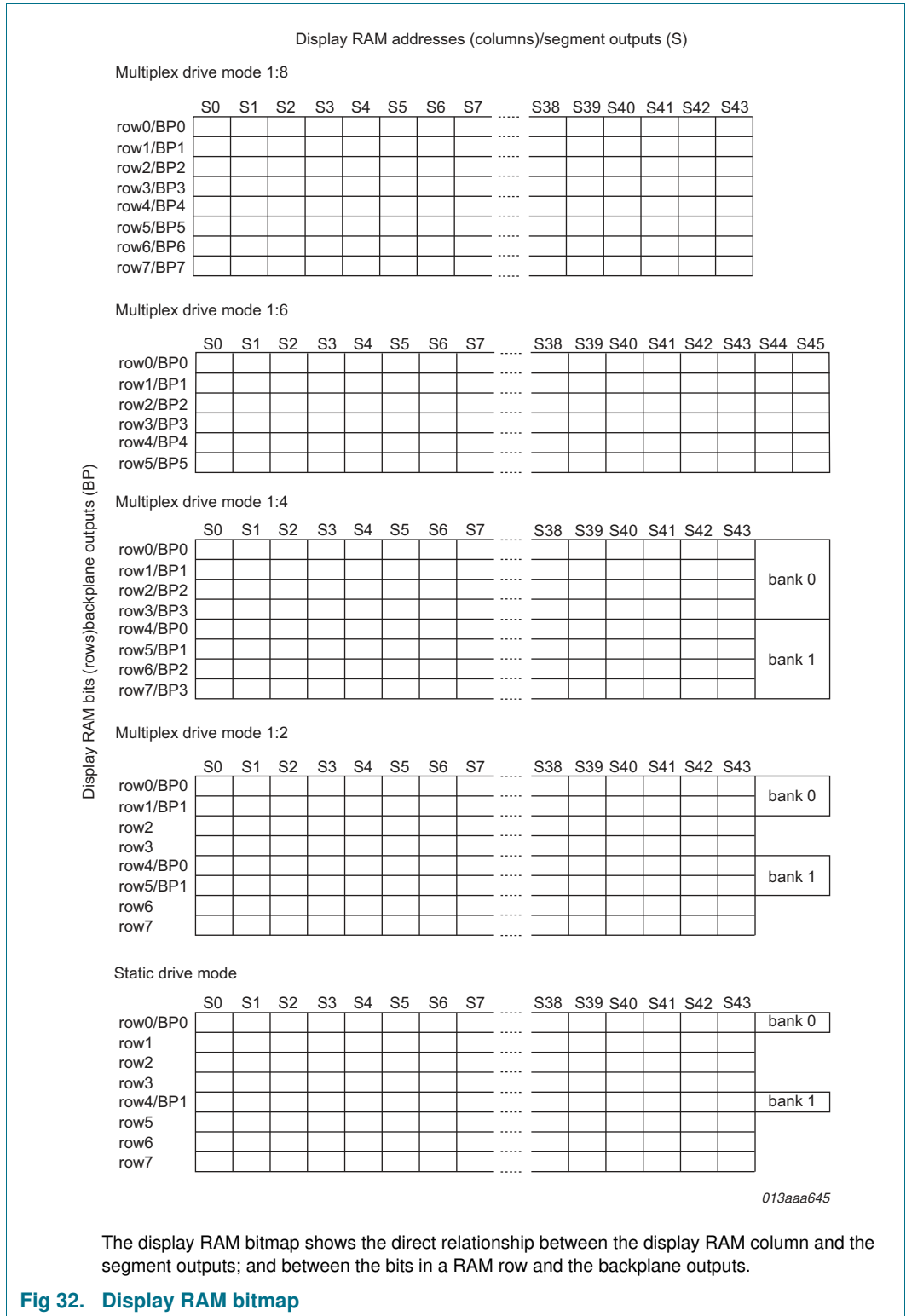

The display RAM bit map, [Figure 32](#), shows row 0 to row 7 which correspond with the backplane outputs BP0 to BP7, and column 0 to column 45 which correspond with the segment outputs S0 to S45. In multiplexed LCD applications, the data of each row of the display RAM is time-multiplexed with the corresponding backplane (row 0 with BP0, row 1 with BP1, and so on).

When display data is transmitted to the PCF8537, the display bytes received are stored in the display RAM in accordance with the selected LCD multiplex drive mode. The data is stored as it arrives. Depending on the current multiplex drive mode, data is stored singularly, in pairs, quadruples, sextuples or bytes.

8.8.1 Data pointer

The addressing mechanism for the display RAM is realized using the data pointer. This allows the loading of an individual display data byte, or a series of display data bytes, into any location of the display RAM. The sequence commences with the initialization of the data pointer by the Load-data-pointer command (see [Table 15 on page 12](#)).

Following this command, an arriving data byte is stored starting at the display RAM address indicated by the data pointer.

After each byte stored, the data pointer is automatically incremented in accordance with the chosen LCD multiplex drive mode configuration:

- by eight (static drive mode)
- by four (1:2 multiplex drive mode)
- by two (1:4 multiplex drive mode)
- by one or two (1:6 multiplex drive mode), see [Figure 37 on page 49](#)
- by one (1:8 multiplex drive mode)

When the address counter reaches the end of the RAM row, it stops incrementing after the last byte is transmitted. Redundant bits of the last byte transmitted are discarded. Additional bytes, sent after the end of the RAM is reached, will be discarded too. The data pointer does not wrap around to the beginning. To send new RAM data, the data pointer must be reset.

If an I²C-bus or SPI-bus data access is terminated early, then the state of the data pointer is unknown. The data pointer must then be re-written before further RAM accesses.

8.8.2 RAM filling in static drive mode

In the static drive mode the eight transmitted data bits are placed in eight successive display RAM columns in row 0 (see [Figure 33](#)).

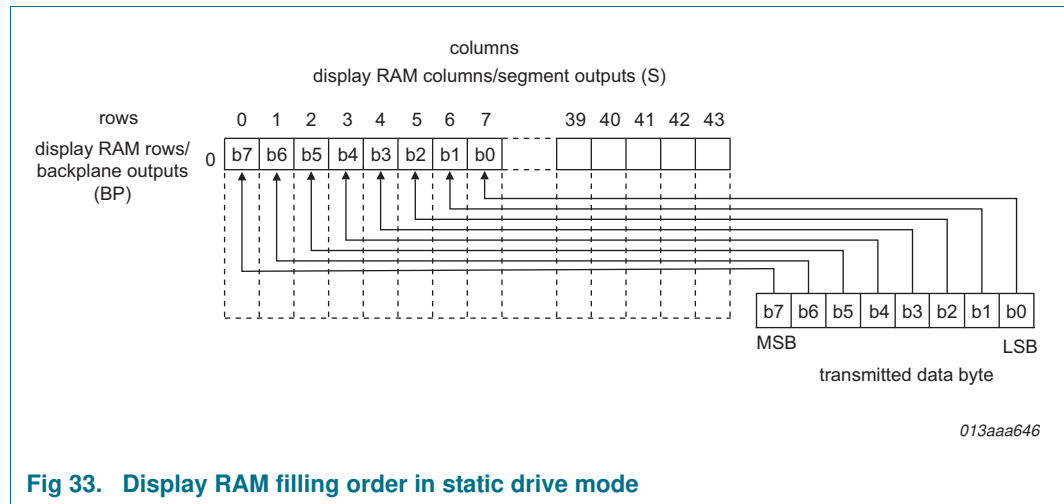

Fig 33. Display RAM filling order in static drive mode

In order to fill the whole RAM row, 6 bytes must be sent to the PCF8537, but the last 4 bits from the last byte are discarded (see [Figure 34](#)).

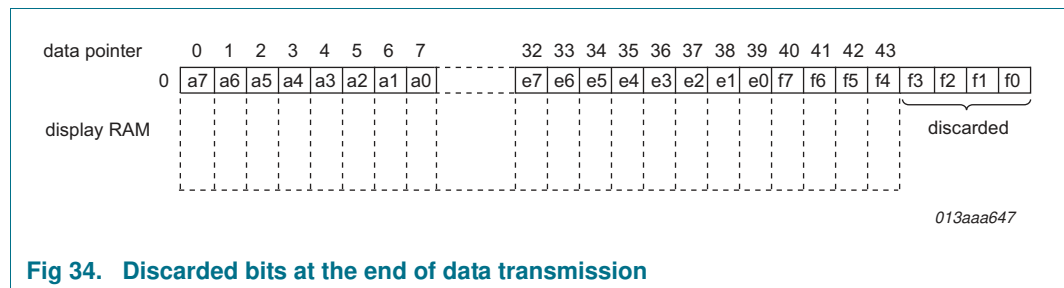

Fig 34. Discarded bits at the end of data transmission

When bit IBS is set to bank 1 (see [Table 18 on page 14](#)), then data is stored in row 4.

8.8.3 RAM filling in 1:2 multiplex drive mode

In the 1:2 multiplex drive mode the eight transmitted data bits are placed in four successive display RAM columns (see [Figure 35](#)). In order to fill the whole two RAM rows 11 bytes need to be sent to the PCF8537.

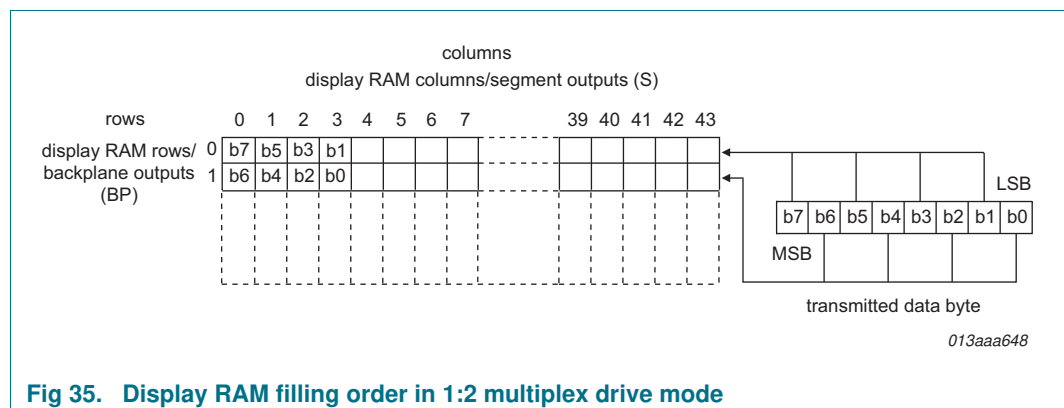

Fig 35. Display RAM filling order in 1:2 multiplex drive mode

When bit IBS is set to bank 1 (see [Table 18 on page 14](#)), then data is stored in row 4 and row 5.

8.8.4 RAM filling in 1:4 multiplex drive mode

In the 1:4 multiplex drive mode the eight transmitted data bits are placed in two successive display RAM columns of four rows (see [Figure 36](#)). In order to fill the whole four RAM rows 22 bytes need to be sent to the PCF8537.

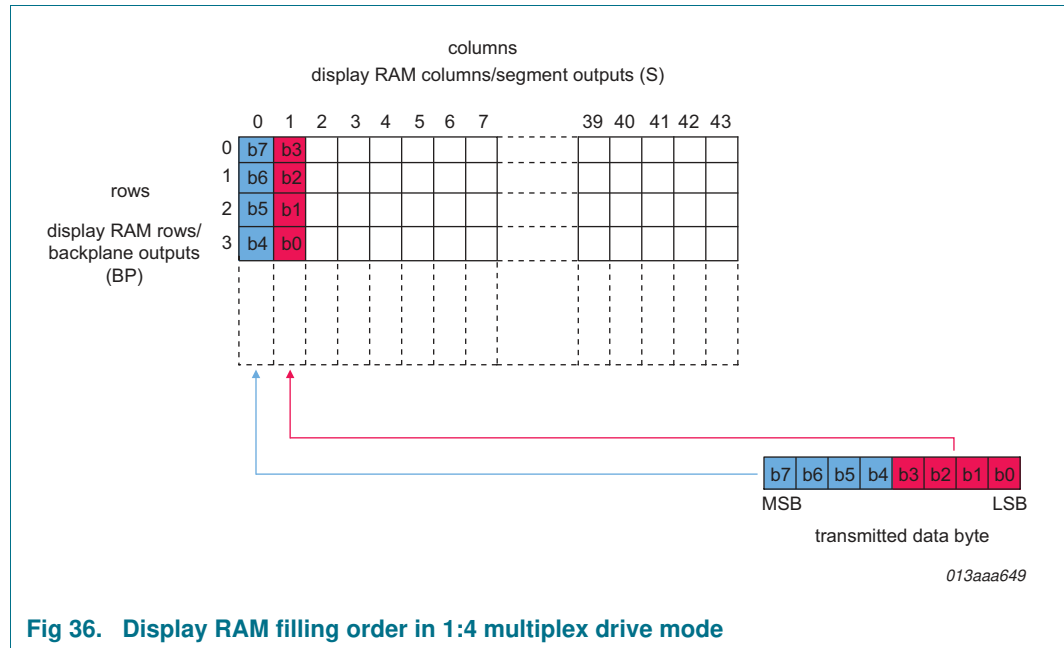

Fig 36. Display RAM filling order in 1:4 multiplex drive mode

When bit IBS is set to bank 1 (see [Table 18 on page 14](#)), then data is stored in rows 4 to row 7.

8.8.5 RAM filling in 1:6 multiplex drive mode

In the 1:6 multiplex drive mode the RAM is organized in six rows and 46 columns. The eight transmitted data bits are placed in such a way, that a column is filled up (see [Figure 37](#)). The remaining bits are wrapped up into the next column. In order to fill the whole RAM addresses 35 bytes need to be sent to the PCF8537, however the four least significant bits of the 35th byte are discarded.

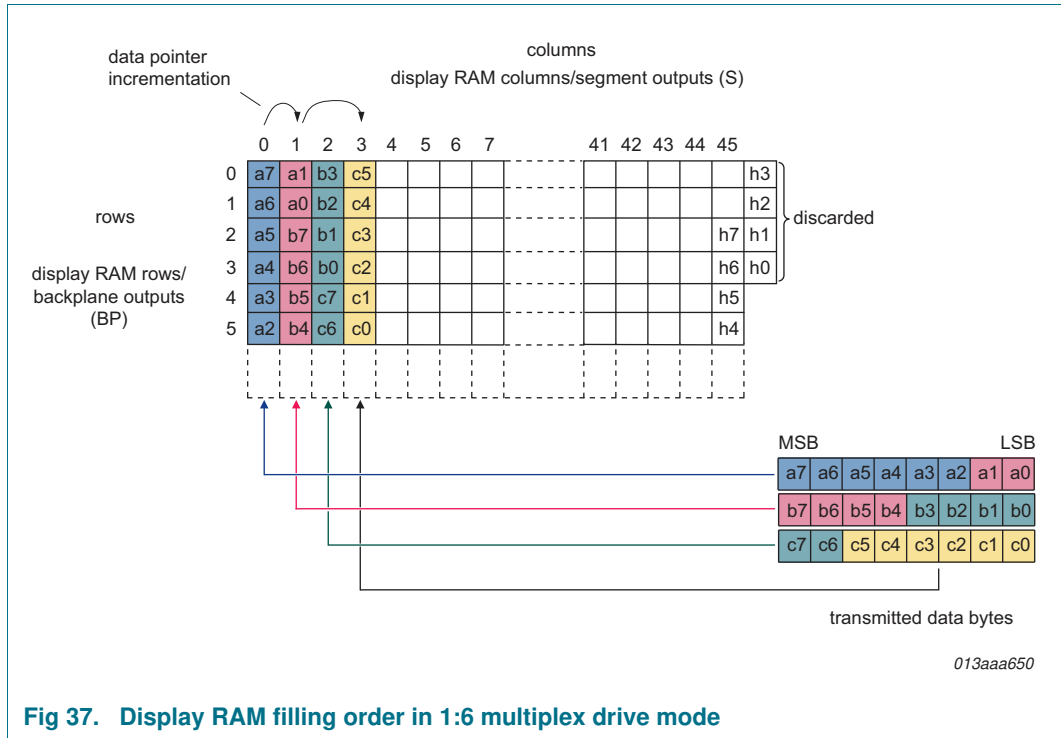

Fig 37. Display RAM filling order in 1:6 multiplex drive mode

When data transfer is initiated, then the MSB of the first byte will always be placed in row 0. Data must be transferred contiguously to achieve RAM filling as described in [Figure 37](#).

8.8.6 RAM filling in 1:8 multiplex drive mode

In the 1:8 multiplex drive mode the eight transmitted data bits are placed into eight rows of one display RAM column (see [Figure 38](#)). In order to fill the whole RAM addresses 44 bytes need to be sent to the PCF8537.

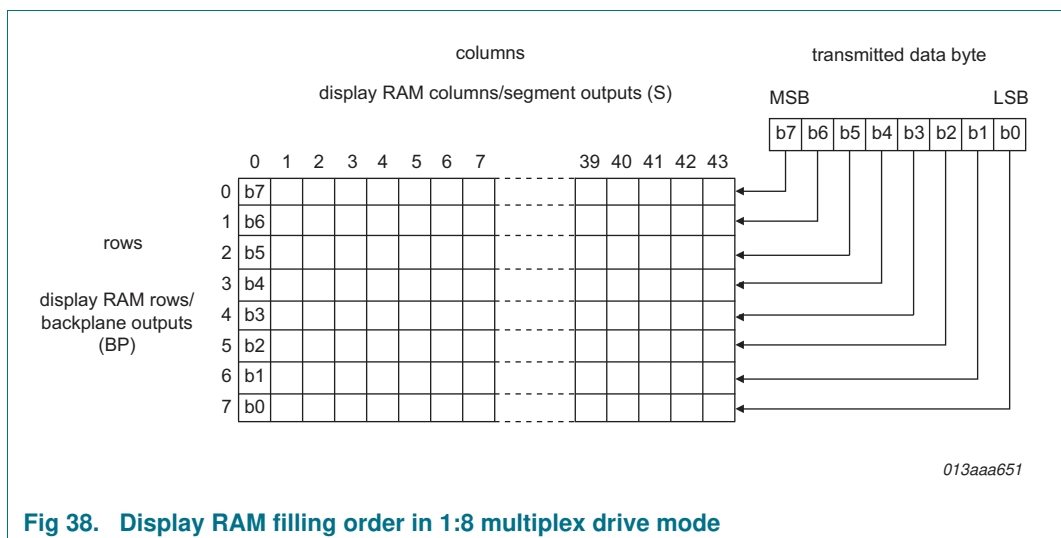

Fig 38. Display RAM filling order in 1:8 multiplex drive mode

8.9 Bank selection

The PCF8537 includes a RAM bank switching feature in the static, 1:2, and 1:4 multiplex drive modes. A bank can be thought of as a collection of RAM rows. The RAM bank switching gives the provision for preparing display information in an alternative bank and to be able to switch to it once it is complete.

There are two banks; bank 0 and bank 1. [Figure 32 on page 45](#) shows the location of these banks relative to the RAM map. Input and output banks can be set independently from one another with the Bank-select command (see [Table 18 on page 14](#)). [Figure 39](#) shows the concept.

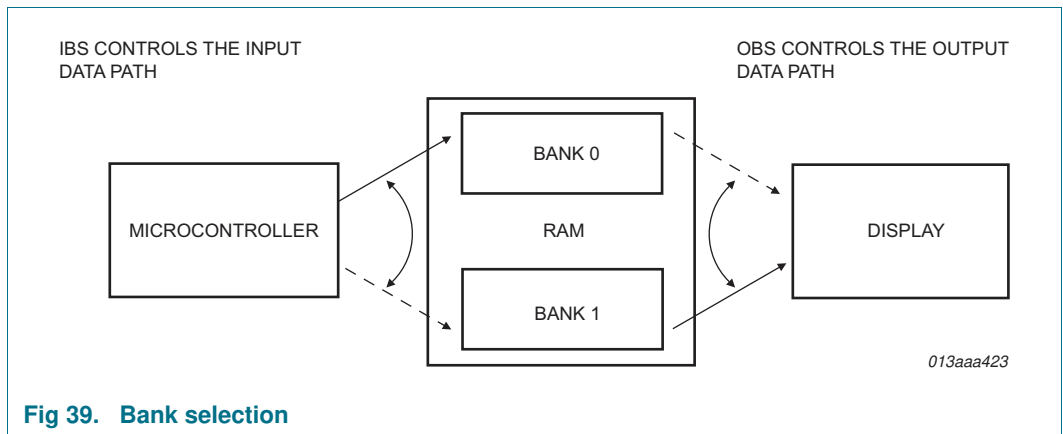

Fig 39. Bank selection

In [Figure 40](#) an example is shown for 1:4 multiplex drive mode where the displayed data is read from the first four rows of the memory (bank 0), while the transmitted data is stored in the second four rows of the memory (bank 1).

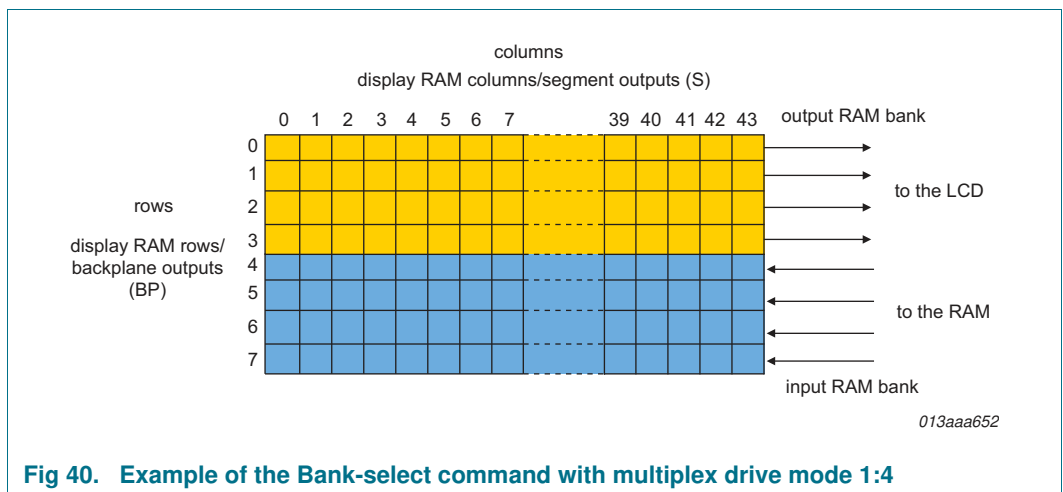

Fig 40. Example of the Bank-select command with multiplex drive mode 1:4

8.9.1 Input bank selection

The IBS (input bank selection) bit of the Bank-select command (see [Table 18](#)) controls where display data is loaded into the display RAM.

The input bank selection works independently of output bank selection.

8.9.2 Output bank selection

The OBS bit of the Bank-select command (see [Table 18 on page 14](#)) controls from which bank display data is taken,

The output bank selection works independently of input bank selection.

9. Bus interfaces

9.1 Control byte

After initiating the communication over the bus and sending the slave address (I²C-bus, see [Section 9.2](#)) or subaddress (SPI-bus, see [Section 9.3](#)), a control byte follows. The purpose of this byte is to indicate both, the content for the following data bytes (RAM or command) and to indicate that more control bytes will follow.

Typical sequences could be:

- Slave address/subaddress - control byte - command byte - command byte - command byte - end
- Slave address/subaddress - control byte - RAM byte - RAM byte - RAM byte - end
- Slave address/subaddress - control byte - command byte - control byte - RAM byte - end

In this way, it is possible to send a mixture of RAM and command data in one access or alternatively, to send just one type of data in one access.

Table 30. Control byte description

Bit	Symbol	Binary value	Description
7	CO		continue bit
		0	last control byte
		1	control bytes continue
6	RS		register selection
		0	command register
		1	data register
5 to 0	-		not relevant

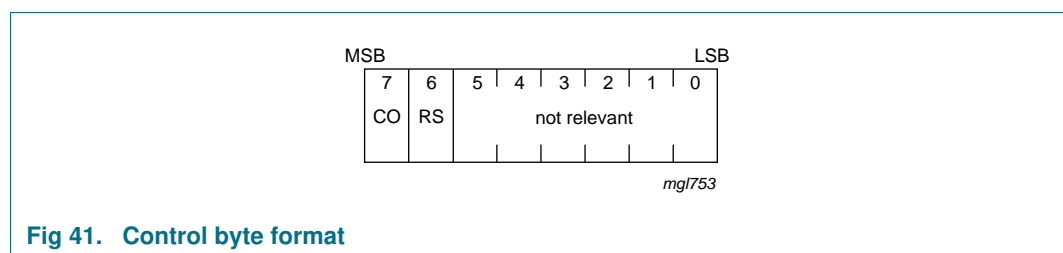

Fig 41. Control byte format

9.2 I²C-bus interface characteristics (PCF8537AH)

The I²C-bus is for bidirectional, two-line communication between different ICs or modules. The two lines are a Serial Data line (SDA) and a Serial Clock line (SCL). Both lines must be connected to a positive supply via a pull-up resistor when connected to the output stages of a device. Data transfer may be initiated only when the bus is not busy.

9.2.1 Bit transfer

One data bit is transferred during each clock pulse. The data on the SDA line must remain stable during the HIGH period of the clock pulse as changes in the data line at this time will be interpreted as a control signal (see [Figure 42](#)).

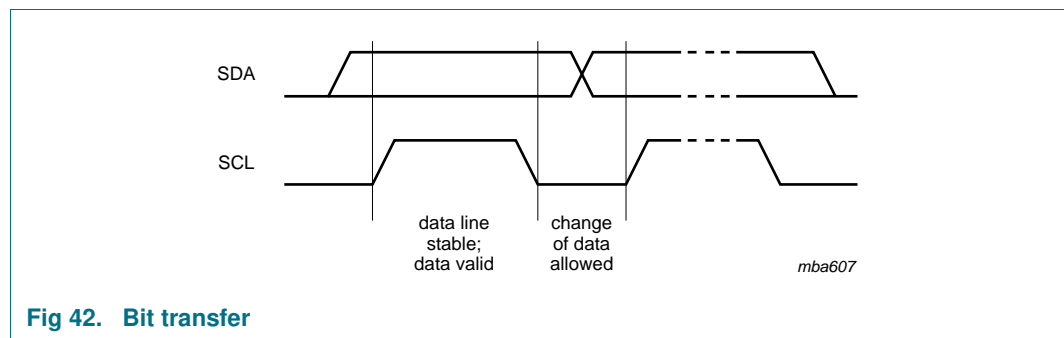

Fig 42. Bit transfer

9.2.2 START and STOP conditions

Both data and clock lines remain HIGH when the bus is not busy.

A HIGH-to-LOW change of the data line, while the clock is HIGH is defined as the START condition (S).

A LOW-to-HIGH change of the data line while the the clock is HIGH is defined as the STOP condition (P).

The START and STOP conditions are shown in [Figure 43](#).

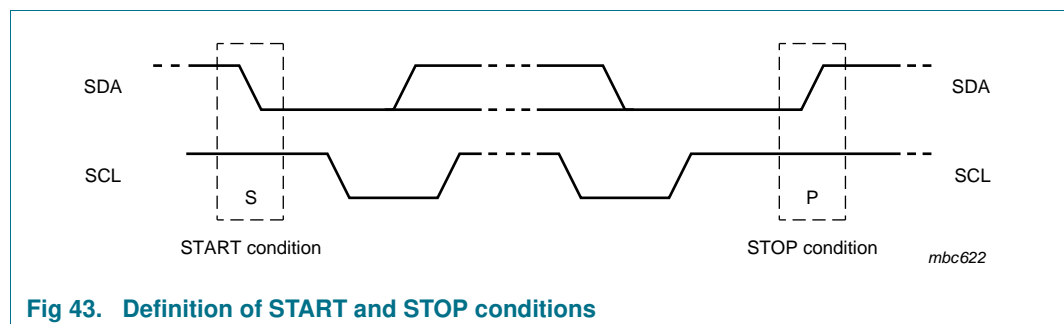

Fig 43. Definition of START and STOP conditions

9.2.3 System configuration

A device generating a message is a transmitter, a device receiving a message is the receiver. The device that controls the message is the master and the devices which are controlled by the master are the slaves. The system configuration is shown in [Figure 44](#).

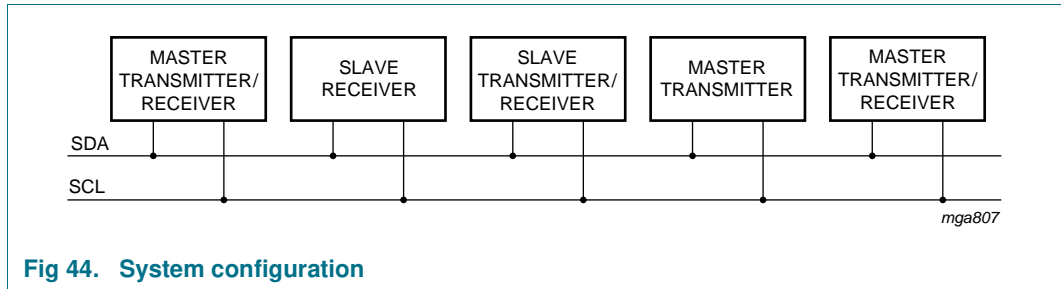

Fig 44. System configuration

9.2.4 Acknowledge

The number of data bytes transferred between the START and STOP conditions from transmitter to receiver is unlimited. Each byte of 8 bits is followed by an acknowledge cycle.

- A slave receiver which is addressed must generate an acknowledge after the reception of each byte.
- Also a master receiver must generate an acknowledge after the reception of each byte that has been clocked out of the slave transmitter.
- The device that acknowledges must pull-down the SDA line during the acknowledge clock pulse, so that the SDA line is stable LOW during the HIGH period of the acknowledge related clock pulse (set-up and hold times must be considered).
- A master receiver must signal an end of data to the transmitter by not generating an acknowledge on the last byte that has been clocked out of the slave. In this event, the transmitter must leave the data line HIGH to enable the master to generate a STOP condition.

Acknowledgement on the I²C-bus is shown in [Figure 45](#).

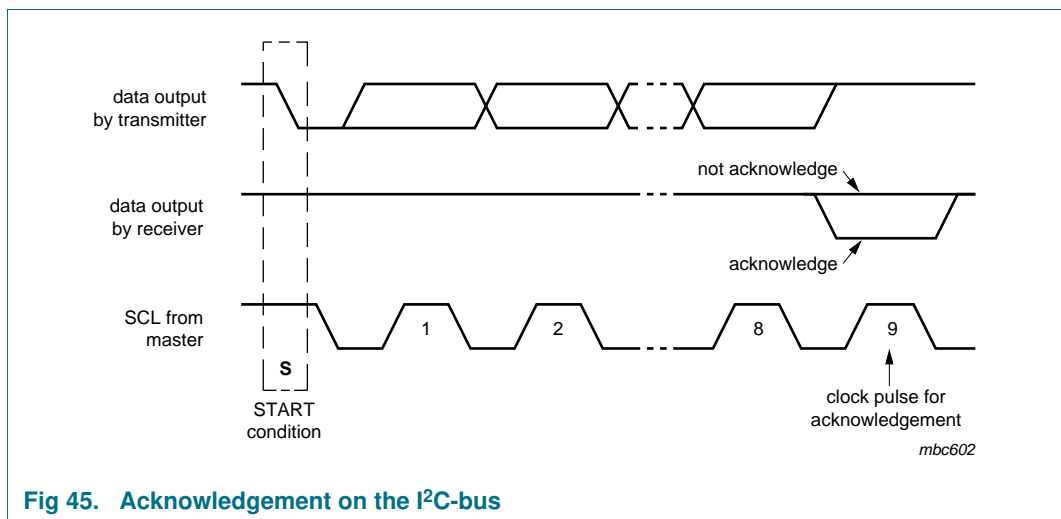

Fig 45. Acknowledgement on the I²C-bus

9.2.5 I²C-bus controller

The PCF8537AH acts as an I²C-bus slave receiver. It does not initiate I²C-bus transfers or transmit data to an I²C-bus master receiver. The only data output from PCF8537AH are the acknowledge signals and the temperature readout byte of the selected device.

9.2.6 Input filters

To enhance noise immunity in electrically adverse environments, RC low-pass filters are provided on the SDA and SCL lines.

9.2.7 I²C-bus slave address

The device selection depends on the I²C-bus slave address.

Two different I²C-bus slave addresses can be used to address the PCF8537AH (see [Table 31](#)).

Table 31. I²C slave address byte

Bit	Slave address							0 LSB
	7 MSB	6	5	4	3	2	1	
	0	1	1	1	0	0	A0	R/W

Bit 1 of the slave address is defined by connecting the input A0 to either V_{SS} (logic 0) or V_{DD} (logic 1). Therefore, two instances of PCF8537AH can be distinguished on the same I²C-bus.

The least significant bit of the slave address byte is bit R/W (see [Table 32](#)).

Table 32. R/W bit description

Symbol	Value	Description
R/W		data read or write selection
	0	write data
	1	read data ^[1]

[1] Only used for temperature readout from PCF8537AH (see [Table 20 on page 15](#)).

9.2.8 I²C-bus protocol

The I²C-bus protocol is shown in [Figure 46](#). The sequence is initiated with a START condition (S) from the I²C-bus master which is followed by one of the two PCF8537AH slave addresses available. All PCF8537AH's with the corresponding A0 level acknowledge in parallel to the slave address, but all PCF8537AH with an alternative A0 level ignore the whole I²C-bus transfer.

After acknowledgement, a control byte follows (see [Section 9.1 on page 52](#)).

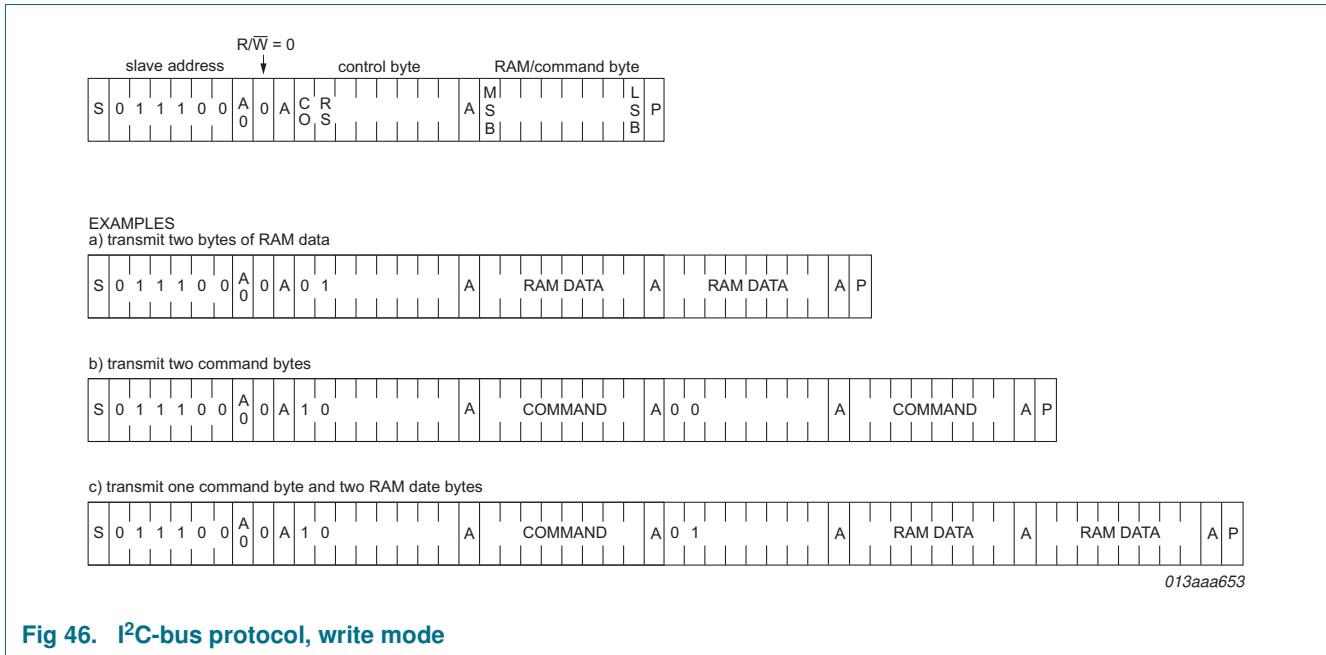

Fig 46. I²C-bus protocol, write mode

The display bytes are stored in the display RAM at the address specified by the data pointer.

The acknowledgement after each byte is made only by the addressed PCF8537AH. After the last display byte, the I²C-bus master issues a STOP condition (P). Alternatively a START may be issued to RESTART an I²C-bus access.

9.2.9 Data read

If a temperature readout (byte TD[7:0]) is made, the R/W bit must be logic 1 and then the next data byte following is provided by the PCF8537AH as shown in [Figure 47](#).

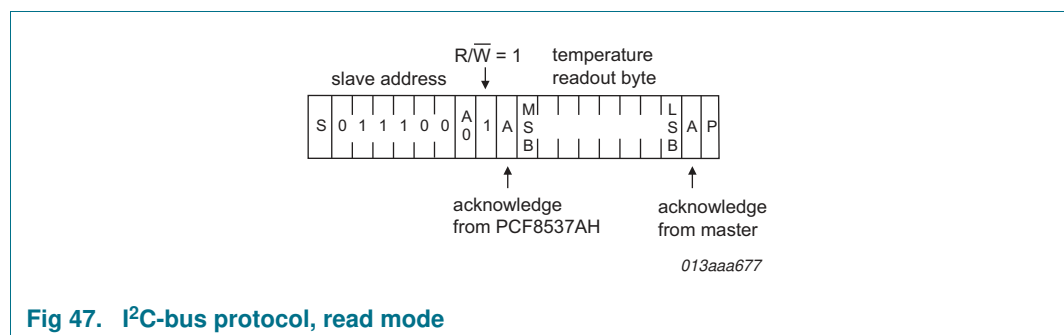

Fig 47. I²C-bus protocol, read mode

9.3 SPI-bus interface (PCF8537BH)

Data transfer to the device is made via a three-line SPI-bus (see [Table 30](#)). The SPI-bus is reset whenever the chip enable pin \overline{CE} is inactive.

Table 33. Serial interface

Pin	Function	Description
\overline{CE}	chip enable input; active LOW ^[1]	when HIGH, the interface is reset;
SCL	serial clock input	-
SDIO	serial data input output	input data is sampled on the rising edge of SCL; data is output on the falling edge of SCL

[1] The chip enable must not be wired permanently LOW.

9.3.1 Data transmission

The chip enable signal is used to identify the transmitted data. Each data transfer is a byte, with the Most Significant Bit (MSB) sent first.

The transmission is controlled by the active LOW chip enable signal \overline{CE} . The first byte transmitted is the subaddress byte.

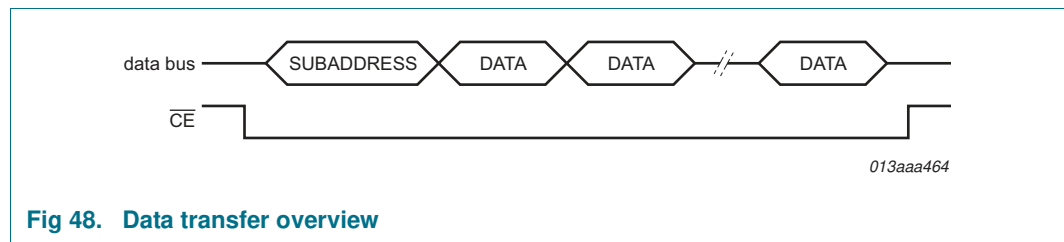

Fig 48. Data transfer overview

The subaddress byte opens the communication with a read/write bit and a subaddress. The subaddress is used to identify multiple devices on one SPI-bus.

Table 34. Subaddress byte definition

Bit	Symbol	Binary value	Description
7	R/\overline{W}		data read or write selection
		0	write data
		1	read data ^[1]
6 to 5	SA[1:0]	01	subaddress ; other codes will cause the device to ignore data transfer
4 to 0	-	-	unused

[1] Only used for temperature readout from PCF8537BH (see [Table 20 on page 15](#)).

After the subaddress byte, a control byte follows (see [Section 9.1 on page 52](#)).

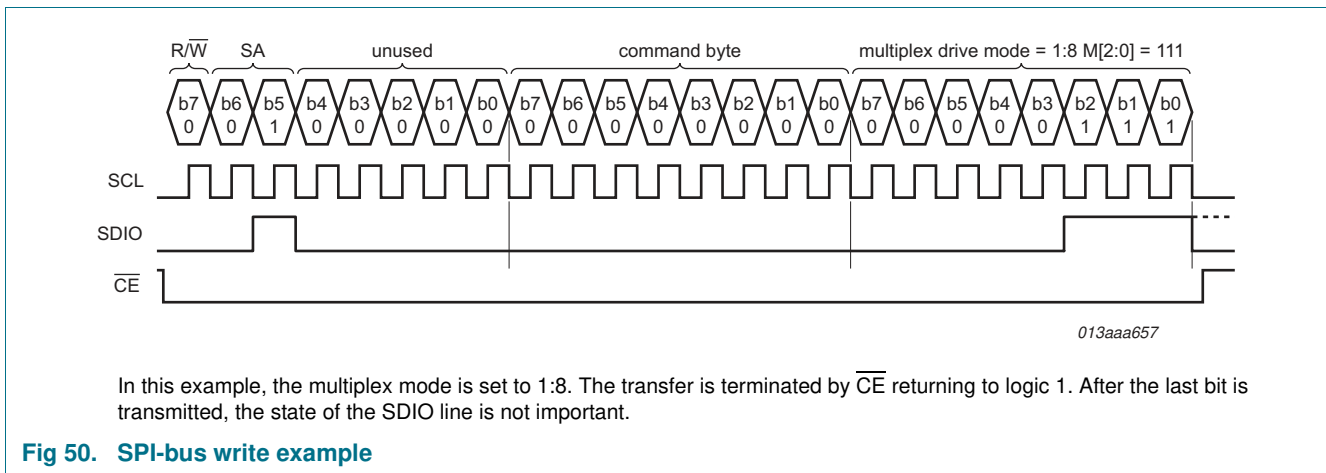
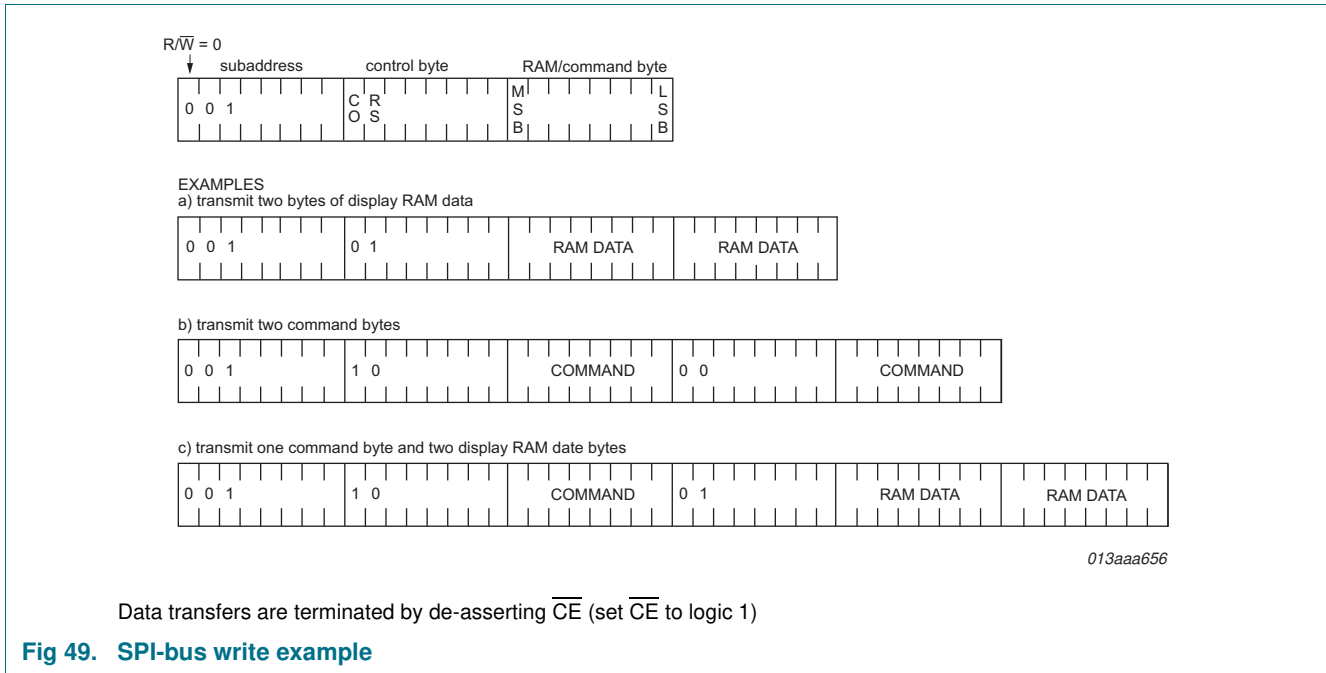

9.3.2 Data read

The temperature readout data byte TD[7:0] can be read from the PCF8537BH.

A readout is initiated by sending the subaddress byte with the R/W bit set high. The transmission is controlled by the active LOW chip enable signal \overline{CE} .

After the last bit of the subaddress byte is transmitted, the PCF8537BH will immediately start to drive the SDIO line. It is only necessary to read the values once, however since the update of the register is asynchronous to the interface clock, it is recommended to read the register twice and check for a stable value.

The readout is terminated by asserting \overline{CE} . At this time, the SDIO bus is released. It is important that the bus is not left floating and that the microcontroller then takes over driving of the bus.

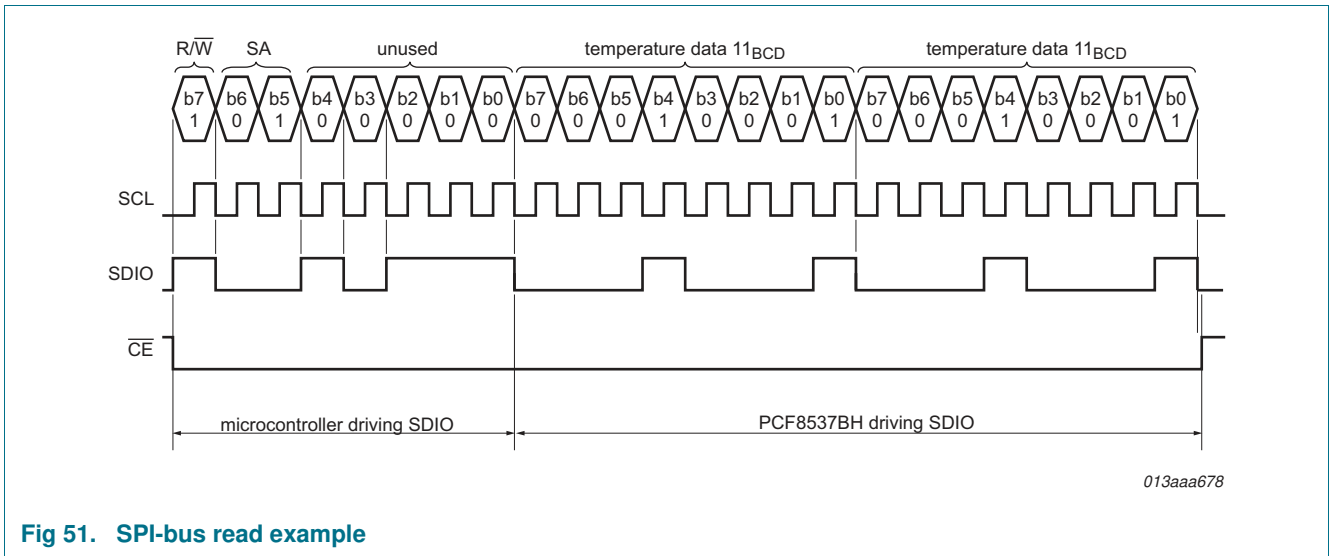
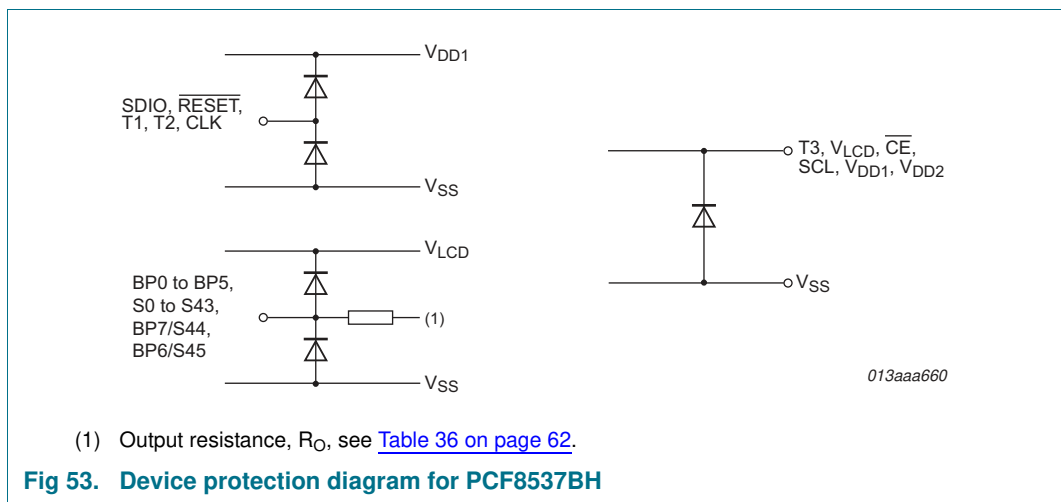
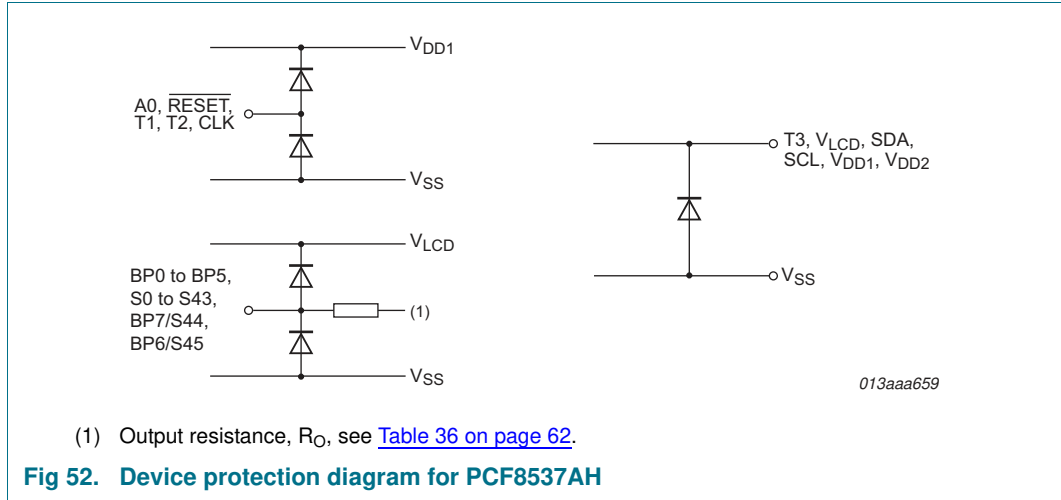

Fig 51. SPI-bus read example

10. Internal circuitry



11. Limiting values

CAUTION



Static voltages across the liquid crystal display can build up when the LCD supply voltage (V_{LCD}) is on while the IC supply voltage (V_{DD}) is off, or vice versa. This may cause unwanted display artifacts. To avoid such artifacts, V_{LCD} and V_{DD} must be applied or removed together.

Table 35. Limiting values

In accordance with the Absolute Maximum Rating System (IEC 60134).

Symbol	Parameter	Conditions	Min	Max	Unit
V_{DD1}	supply voltage 1	digital	-0.5	+6.5	V
V_{DD2}	supply voltage 2	analog	-0.5	+6.5	V
I_{DD1}	supply current 1	digital	-50	+50	mA
I_{DD2}	supply current 2	analog	-50	+50	mA
V_{LCD}	LCD supply voltage		-0.5	+10	V
$I_{DD(LCD)}$	LCD supply current		-50	+50	mA
V_i	input voltage	on pins CLK, \overline{CE} , SDA, SCL, A0, SDIO, T1, T2	-0.5	+6.5	V
I_i	input current		-10	+10	mA
V_O	output voltage	on pins S0 to S45, BP0 to BP7	-0.5	+10	V
		on pins SDA, SDIO, CLK	-0.5	+6.5	V
I_O	output current		-10	+10	mA
I_{SS}	ground supply current		-50	+50	mA
P_{tot}	total power dissipation		-	400	mW
P/out	power dissipation per output		-	100	mW
V_{ESD}	electrostatic discharge voltage	HBM	[1]	-	±4500 V
		CDM	[2]	-	±1500 V
I_{lu}	latch-up current		[3]	-	200 mA
T_{stg}	storage temperature		[4]	-65	+150 °C
T_{amb}	ambient temperature	operating device		-40	+85 °C

[1] Pass level; Human Body Model (HBM), according to [Ref. 6 "JESD22-A114"](#).

[2] Pass level; Charged-Device Model (CDM), according to [Ref. 7 "JESD22-C101"](#).

[3] Pass level; latch-up testing according to [Ref. 8 "JESD78"](#) at maximum ambient temperature ($T_{amb(max)}$).

[4] According to the NXP store and transport requirements (see [Ref. 10 "NX3-00092"](#)) the devices have to be stored at a temperature of +8 °C to +45 °C and a humidity of 25 % to 75 %. For long term storage products deviant conditions are described in that document.

12. Static characteristics

Table 36. Static characteristics

$V_{DD1} = 1.8\text{ V to }5.5\text{ V}$; $V_{DD2} = 2.5\text{ V to }5.5\text{ V}$; $V_{SS} = 0\text{ V}$; $V_{LCD} = 2.5\text{ V to }9.0\text{ V}$; $T_{amb} = -40\text{ °C to }+85\text{ °C}$; temperature measurement enabled; 1:8 multiplex drive mode; $1/4$ bias; LCD outputs are open circuit; RAM is all written with logic 1; inputs at V_{SS} or V_{DD} ; internal clock with maximum prescale factor; I²C-bus/SPI-bus inactive; unless otherwise specified.

Symbol	Parameter	Conditions	Min	Typ	Max	Unit
Supplies						
V_{DD1}	supply voltage 1	logic	1.8	-	5.5	V
V_{DD2}	supply voltage 2	analog; $V_{DD2} \geq V_{DD1}$				
		charge pump set to $2 \times V_{DD2}$	2.5	-	5.5	V
		charge pump set to $3 \times V_{DD2}$	2.5	-	5.5	V
V_{LCD}	LCD supply voltage	$V_{LCD} \geq V_{DD2}$	[1] 2.5	-	9.0	V
ΔV_{LCD}	LCD voltage variation	$V_{DD1} = V_{DD2} = 5.0\text{ V}$; $V_{LCD} = 6.99\text{ V}$	[2] -0.10	-	+0.10	V
I_{DD1}	supply current 1	digital; display disabled; charge pump off	-	90	200	μA
I_{DD2}	supply current 2	display disabled; charge pump off; external V_{LCD}	-	0.5	-	μA
		$V_{DD2} = 5.5\text{ V}$; charge pump set to $2 \times V_{DD2}$; internal $V_{LCD} = 7.0\text{ V}$				
		display disabled	-	30	40	μA
		display enabled	[3] -	200	-	μA
$I_{DD(LCD)}$	LCD supply current	external $V_{LCD} = 7.0\text{ V}$; display enabled;	-	85	-	μA
$I_{DD(pd)}$	power-down mode supply current	on pin V_{DD1}	-	1	3	μA
$I_{LCD(pd)}$	power-down LCD current		-	15	25	μA
T_{acc}	temperature accuracy	readout temperature error; $V_{DD1} = 5.0\text{ V}$				
		$T_{amb} = -40\text{ °C to }+85\text{ °C}$	-5	-	+5	$^{\circ}\text{C}$
		$T_{amb} = 25\text{ °C}$	-3	-	+3	$^{\circ}\text{C}$
Logic						
V_I	input voltage		$V_{SS} - 0.5$	-	$V_{DD} + 0.5$	V
V_{IL}	LOW-level input voltage	on pins CLK and A0	-	-	$0.3V_{DD}$	V
V_{IH}	HIGH-level input voltage	on pins CLK and A0	$0.7V_{DD}$	-	-	V
V_O	output voltage		-0.5	-	$V_{DD} + 0.5$	V
V_{OH}	HIGH-level output voltage	on pin CLK	$0.8V_{DD}$	-	-	V
V_{OL}	LOW-level output voltage	on pin CLK	-	-	$0.2V_{DD}$	V
I_{OH}	HIGH-level output current	output source current; $V_{OH} = 4.6\text{ V}$; $V_{DD} = 5\text{ V}$; on pin CLK	1	-	-	mA

Table 36. Static characteristics ...continued

$V_{DD1} = 1.8\text{ V to }5.5\text{ V}$; $V_{DD2} = 2.5\text{ V to }5.5\text{ V}$; $V_{SS} = 0\text{ V}$; $V_{LCD} = 2.5\text{ V to }9.0\text{ V}$; $T_{amb} = -40\text{ }^{\circ}\text{C to }+85\text{ }^{\circ}\text{C}$; temperature measurement enabled; 1:8 multiplex drive mode; $1/4$ bias; LCD outputs are open circuit; RAM is all written with logic 1; inputs at V_{SS} or V_{DD} ; internal clock with maximum prescale factor; $I^2\text{C}$ -bus/SPI-bus inactive; unless otherwise specified.

Symbol	Parameter	Conditions	Min	Typ	Max	Unit
I_{OL}	LOW-level output current	output sink current; $V_{OL} = 0.4\text{ V}$; $V_{DD} = 5\text{ V}$; on pin CLK	1	-	-	mA
V_{POR}	power-on reset voltage		[4]	-	1.6	V
I_L	leakage current	$V_i = V_{DD}$ or V_{SS} ; on pins CLK and A0	-1	-	+1	μA

I²C- and SPI-bus lines; pins SDA, SCL and SDIO

V_i	input voltage	pins SDA, SCL	$V_{SS} - 0.5$	-	5.5	V
		pin SDIO	$V_{SS} - 0.5$	-	$V_{DD} + 0.5$	V
V_{IL}	LOW-level input voltage	pins SDA, SCL, and SDIO	-	-	$0.3V_{DD}$	V
V_{IH}	HIGH-level input voltage	pins SDA, SCL, and SDIO	$0.7V_{DD}$	-	-	V
V_O	output voltage	pins SDA and SCL	-0.5	-	5.5	V
		SDIO	-0.5	-	$V_{DD} + 0.5$	V
I_{OL}	LOW-level output current	$V_{OL} = 0.4\text{ V}$; $V_{DD} = 5\text{ V}$; on pin SDA and SDIO	3	-	-	mA
I_{OH}	HIGH-level output current	$V_{OH} = 4.6\text{ V}$; $V_{DD} = 5\text{ V}$; on pin SDIO	3	-	-	mA
I_L	leakage current	$V_i = V_{DD}$ or V_{SS}	-1	-	+1	μA

LCD outputs

ΔV_O	output voltage variation	on pins BP0 to BP7	[5]	-15	-	+15	mV
		on pins S0 to S45	[6]	-15	-	+15	mV
R_O	output resistance	$V_{LCD} = 7\text{ V}$; on pins BP0 to BP7	[7]	0.3	0.8	1.5	$\text{k}\Omega$
		$V_{LCD} = 7\text{ V}$; on pins S0 to S45	[7]	0.6	1.5	3	$\text{k}\Omega$

- [1] When supplying external V_{LCD} it must be $V_{LCD} \geq V_{DD2}$. Also when using the internal charge pump to generate a certain V_{LCD} , $VPR[7:0]$ must be set to a value that the voltage is higher than V_{DD2} (see [Section 8.4.2](#)).
- [2] Calibrated at testing stage. V_{LCD} temperature compensation is disabled.
- [3] Tested on sample basis.
- [4] If $V_{DD1} < V_{POR}$ a reset occurs.
- [5] Variation between any 2 backplanes on a given voltage level; static measured.
- [6] Variation between any 2 segments on a given voltage level; static measured.
- [7] Outputs measured one at a time.

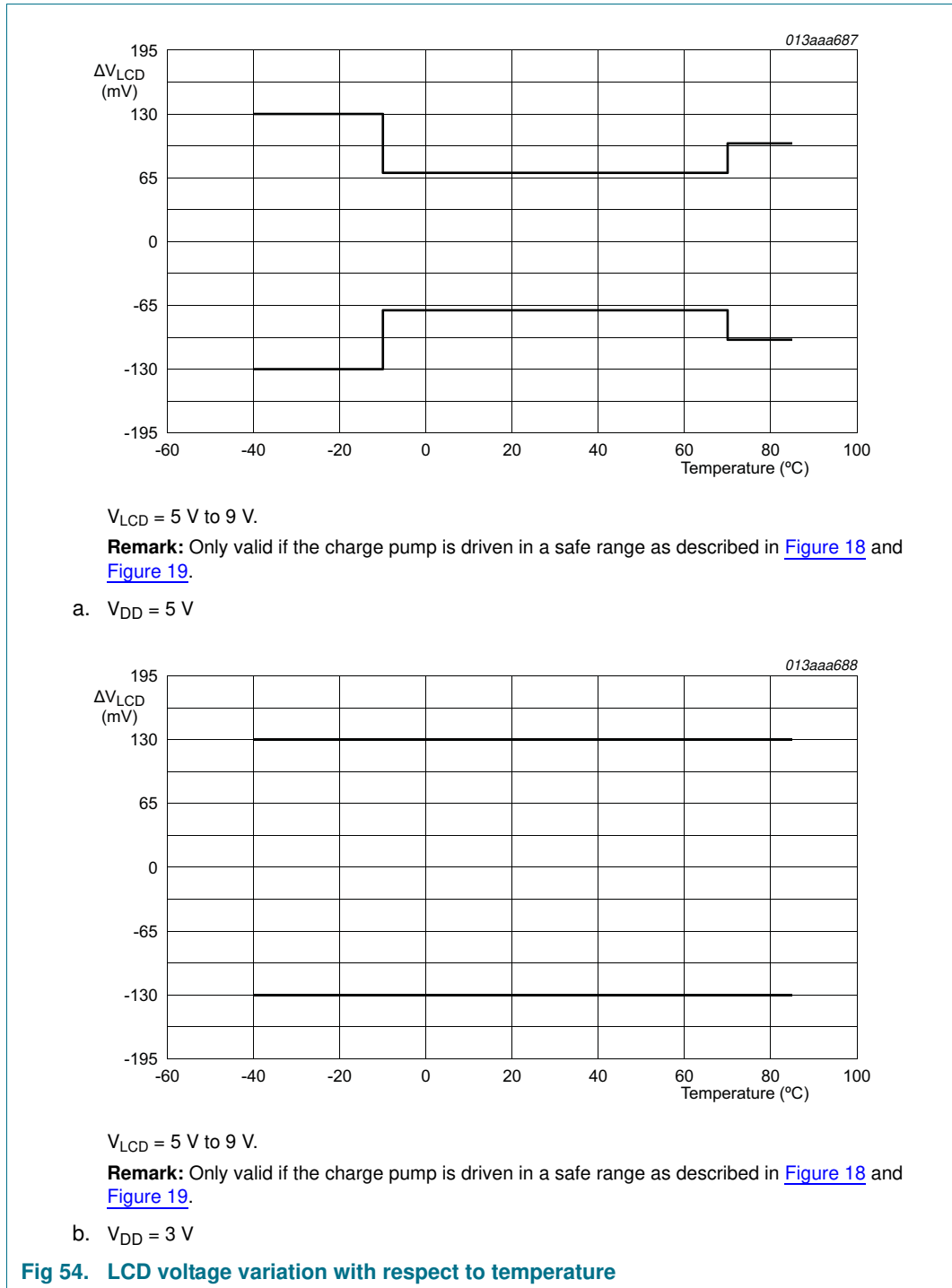

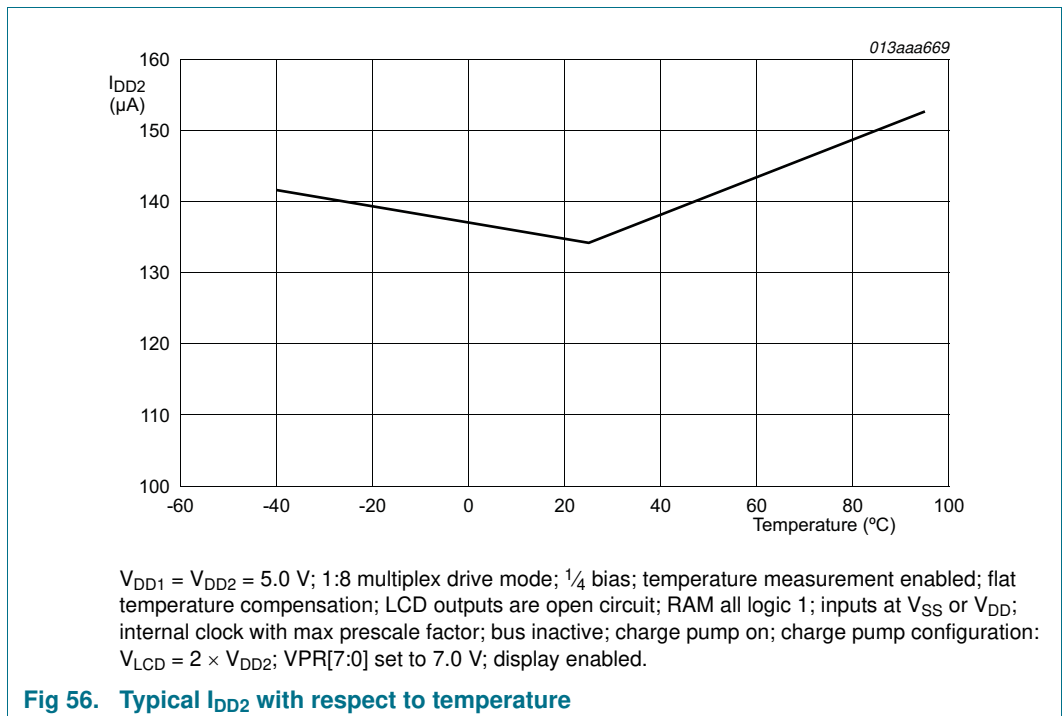
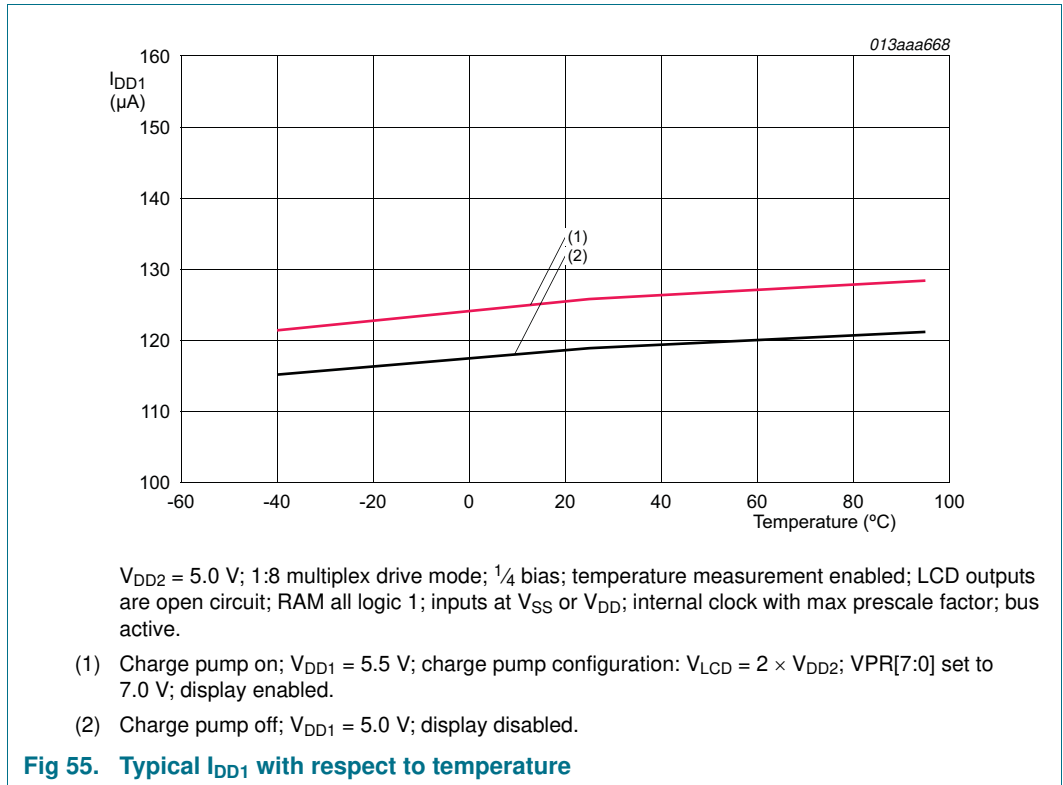

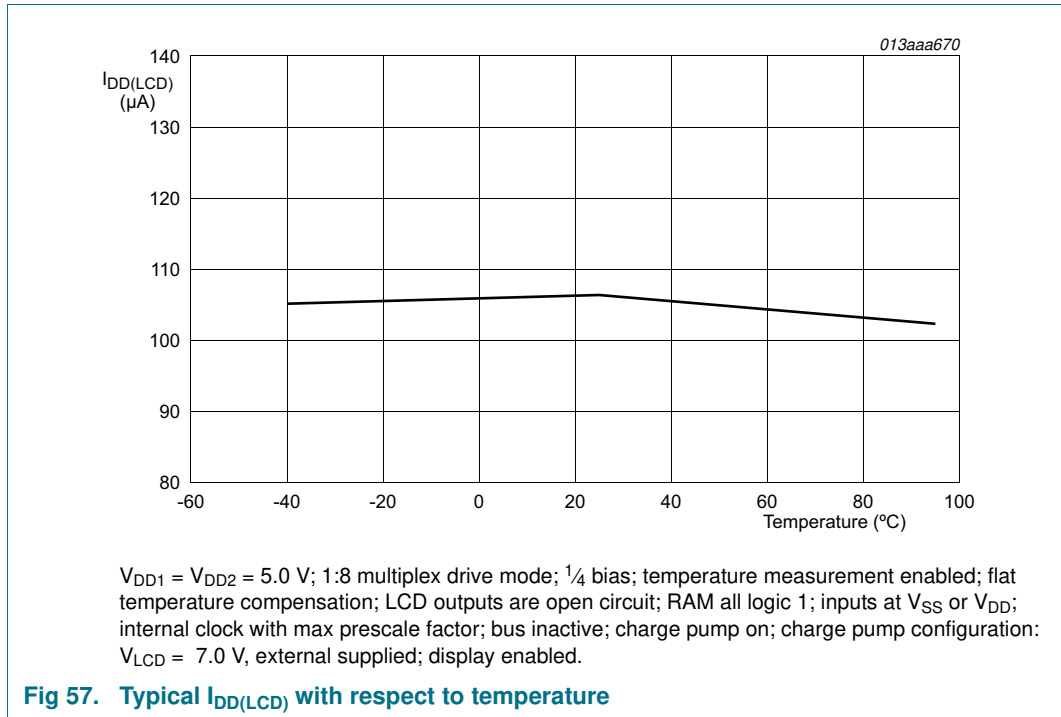

13. Dynamic characteristics

Table 37. Dynamic characteristics

$V_{DD} = 1.8\text{ V to }5.5\text{ V}$; $V_{SS} = 0\text{ V}$; $V_{LCD} = 2.5\text{ V to }9.0\text{ V}$; $T_{amb} = -40\text{ }^{\circ}\text{C to }+85\text{ }^{\circ}\text{C}$; unless otherwise specified.

Symbol	Parameter	Conditions	Min	Typ	Max	Unit	
$f_{clk(ext)}$	external clock frequency		450	-	14500	Hz	
$t_{clk(H)}$	clock HIGH time	external clock source used	33	-	-	μs	
$t_{clk(L)}$	clock LOW time		33	-	-	μs	
f_{clk}	clock frequency	on pin CLK; see Table 17	[1]	7800	9600	11 040	Hz
$t_{w(rst)L}$	LOW-level reset time		400	-	-	ns	

[1] Frequency present on OSCCLK with default display frequency division factor.

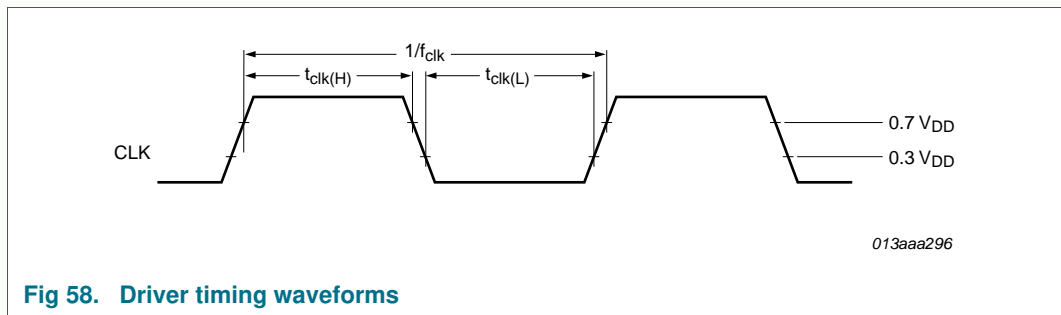

Fig 58. Driver timing waveforms

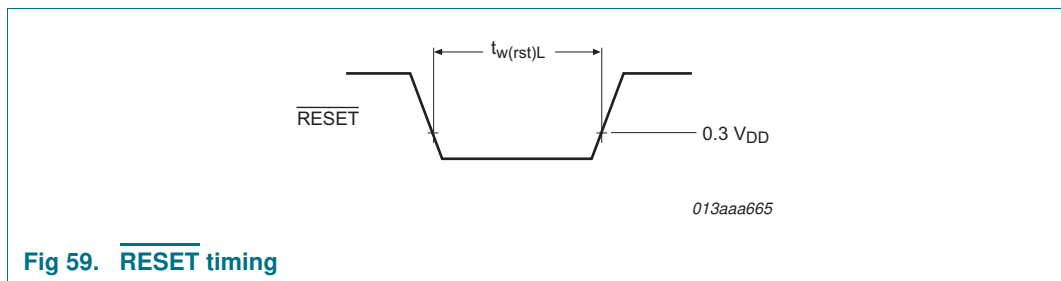

Fig 59. RESET timing

Table 38. Timing characteristics: I²C-bus

$V_{DD1} = 1.8\text{ V to }5.5\text{ V}$; $V_{DD2} = 2.5\text{ V to }5.5\text{ V}$; $V_{SS} = 0\text{ V}$; $T_{amb} = -40\text{ }^{\circ}\text{C to }+85\text{ }^{\circ}\text{C}$; unless otherwise specified.

Symbol	Parameter	Conditions	Min	Typ	Max	Unit
f_{SCL}	SCL clock frequency		-	-	400	kHz
t_{BUF}	bus free time between a STOP and START condition		1.3	-	-	μs
$t_{HD;STA}$	hold time (repeated) START condition		0.6	-	-	μs
$t_{SU;STA}$	set-up time for a repeated START condition		0.6	-	-	μs
$t_{VD;DAT}$	data valid time	[4]	-	-	0.9	μs
$t_{VD;ACK}$	data valid acknowledge time	[5]	-	-	0.9	μs
t_{LOW}	LOW period of the SCL clock		1.3	-	-	μs
t_{HIGH}	HIGH period of the SCL clock		0.6	-	-	μs
t_f	fall time	of both SDA and SCL signals	-	-	0.3	μs
t_r	rise time	of both SDA and SCL signals	-	-	0.3	μs
C_b	capacitive load for each bus line		-	-	400	pF
$t_{SU;DAT}$	data set-up time		100	-	-	ns
$t_{HD;DAT}$	data hold time		0	-	-	ns
$t_{SU;STO}$	set-up time for STOP condition		0.6	-	-	μs
$t_{w(\text{spike})}$	spike pulse width		-	-	50	ns

- [1] Internal calibration made with OTP so that the maximum variation is $\pm 15\%$ over whole temperature and voltage range. The typical f_{clk} frequency generates a typical frame frequency of 200 Hz when the default frequency division factor is used.
- [2] The typical value is defined at $V_{DD1} = V_{DD2} = 5.0\text{ V}$ and $30\text{ }^{\circ}\text{C}$.
- [3] All timing values are valid within the operating supply voltage and ambient temperature range and are referenced to V_{IL} and V_{IH} with an input voltage swing of V_{SS} to V_{DD} .
- [4] $t_{VD;DAT}$ = minimum time for valid SDA output following SCL LOW.
- [5] $t_{VD;ACK}$ = time for acknowledgement signal from SCL LOW to SDA output LOW.

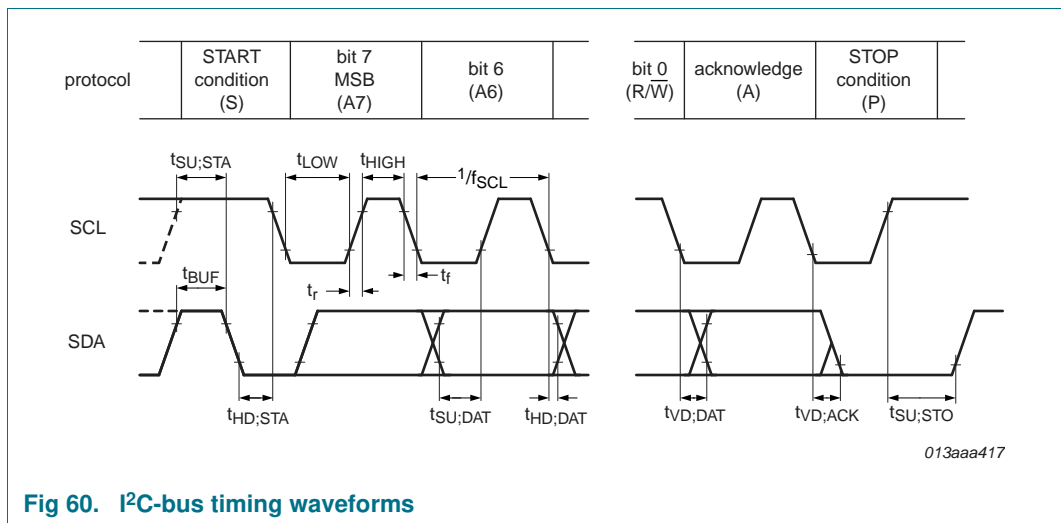

Fig 60. I²C-bus timing waveforms

Table 39. Timing characteristics: SPI-bus

$V_{DD} = 1.8\text{ V to }5.5\text{ V}$; $V_{SS} = 0\text{ V}$; $T_{amb} = -40\text{ }^{\circ}\text{C to }+85\text{ }^{\circ}\text{C}$. All timing values are valid within the operating supply voltage and temperature range and referenced to V_{IL} and V_{IH} with an input voltage swing of V_{SS} to V_{DD} .

Symbol	Parameter	Conditions	$V_{DD} < 2.7\text{ V}$		$V_{DD} \geq 2.7\text{ V}$		Unit
			Min	Max	Min	Max	
Timing characteristics (see Figure 61)							
$f_{clk(SCL)}$	SCL clock frequency		-	2	-	5	MHz
t_{SCL}	SCL time		500	-	200	-	ns
$t_{clk(H)}$	clock HIGH time		200	-	80	-	ns
$t_{clk(L)}$	clock LOW time		200	-	80	-	ns
t_r	rise time	for SCL signal	-	100	-	100	ns
t_f	fall time	for SCL signal	-	100	-	100	ns
$t_{su}(\overline{CE})$	\overline{CE} set-up time		150	-	80	-	ns
$t_h(\overline{CE})$	\overline{CE} hold time		0	-	0	-	ns
$t_{rec}(\overline{CE})$	\overline{CE} recovery time		100	-	100	-	ns
t_{su}	set-up time	set-up time for SDIO data	35	-	10	-	ns
t_h	hold time	hold time for SDIO data	25	-	15	-	ns

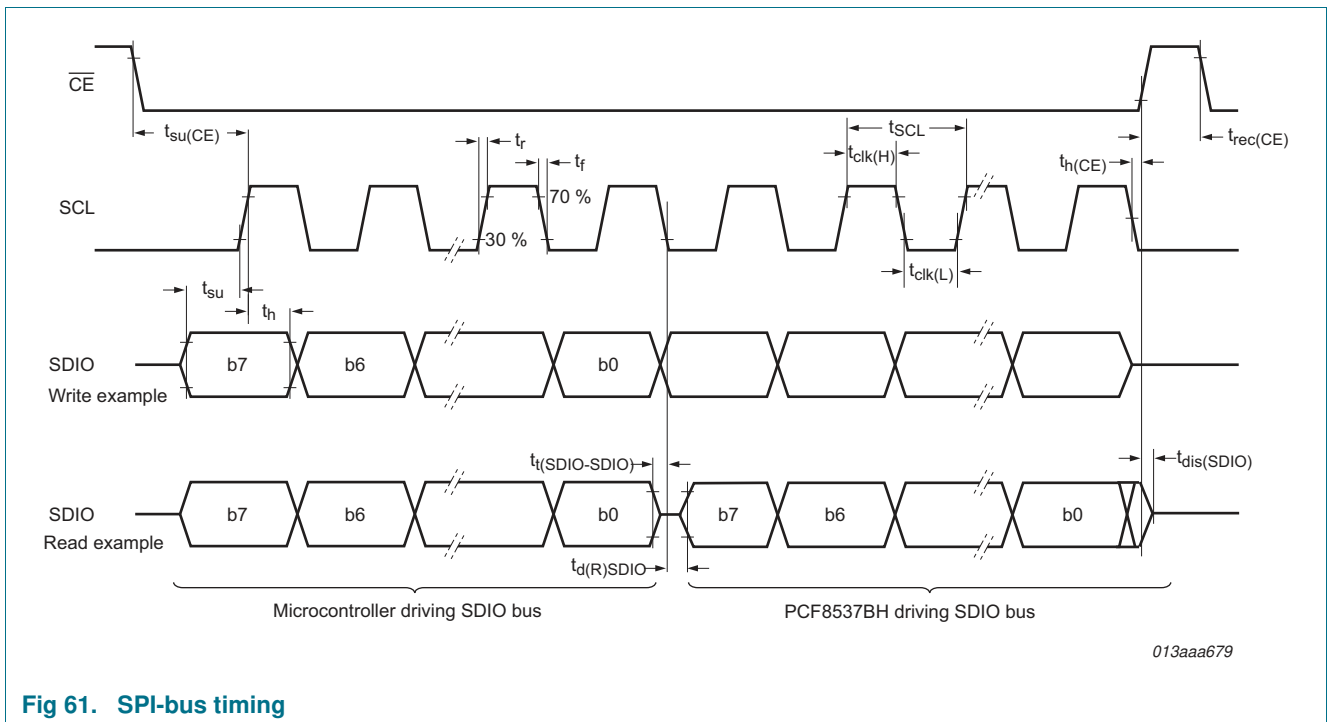

Fig 61. SPI-bus timing

14. Package outline

TQFP64: plastic thin quad flat package; 64 leads; body 10 x 10 x 1.0 mm

SOT357-1

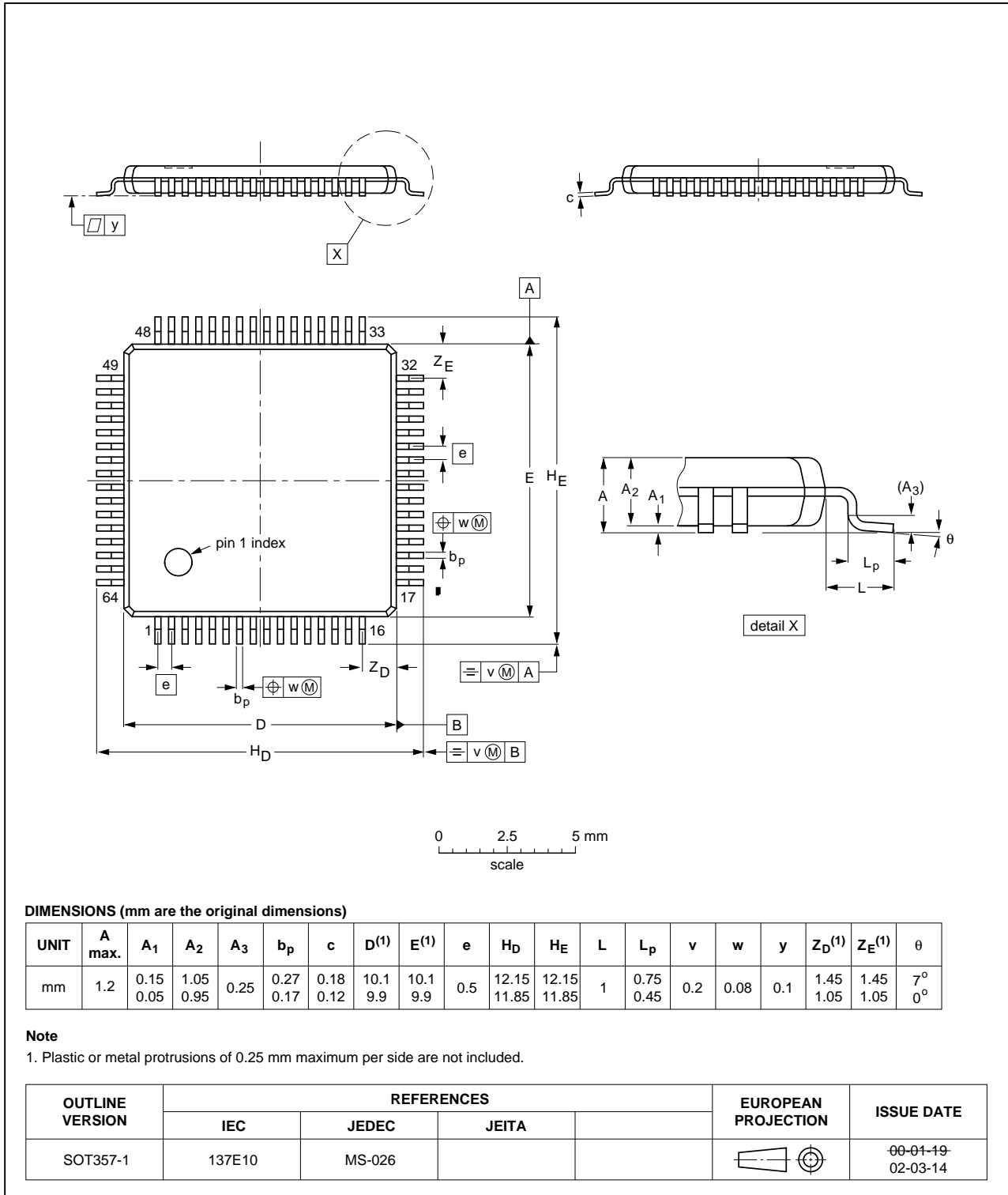

Fig 62. Package outline SOT357-1 (TQFP64)

15. Handling information

All input and output pins are protected against ElectroStatic Discharge (ESD) under normal handling. When handling Metal-Oxide Semiconductor (MOS) devices ensure that all normal precautions are taken as described in *JESD625-A*, *IEC 61340-5* or equivalent standards.

16. Soldering of SMD packages

This text provides a very brief insight into a complex technology. A more in-depth account of soldering ICs can be found in Application Note *AN10365 "Surface mount reflow soldering description"*.

16.1 Introduction to soldering

Soldering is one of the most common methods through which packages are attached to Printed Circuit Boards (PCBs), to form electrical circuits. The soldered joint provides both the mechanical and the electrical connection. There is no single soldering method that is ideal for all IC packages. Wave soldering is often preferred when through-hole and Surface Mount Devices (SMDs) are mixed on one printed wiring board; however, it is not suitable for fine pitch SMDs. Reflow soldering is ideal for the small pitches and high densities that come with increased miniaturization.

16.2 Wave and reflow soldering

Wave soldering is a joining technology in which the joints are made by solder coming from a standing wave of liquid solder. The wave soldering process is suitable for the following:

- Through-hole components
- Leaded or leadless SMDs, which are glued to the surface of the printed circuit board

Not all SMDs can be wave soldered. Packages with solder balls, and some leadless packages which have solder lands underneath the body, cannot be wave soldered. Also, leaded SMDs with leads having a pitch smaller than ~0.6 mm cannot be wave soldered, due to an increased probability of bridging.

The reflow soldering process involves applying solder paste to a board, followed by component placement and exposure to a temperature profile. Leaded packages, packages with solder balls, and leadless packages are all reflow solderable.

Key characteristics in both wave and reflow soldering are:

- Board specifications, including the board finish, solder masks and vias
- Package footprints, including solder thieves and orientation
- The moisture sensitivity level of the packages
- Package placement
- Inspection and repair
- Lead-free soldering versus SnPb soldering

16.3 Wave soldering

Key characteristics in wave soldering are:

- Process issues, such as application of adhesive and flux, clinching of leads, board transport, the solder wave parameters, and the time during which components are exposed to the wave
- Solder bath specifications, including temperature and impurities

16.4 Reflow soldering

Key characteristics in reflow soldering are:

- Lead-free versus SnPb soldering; note that a lead-free reflow process usually leads to higher minimum peak temperatures (see [Figure 63](#)) than a SnPb process, thus reducing the process window
- Solder paste printing issues including smearing, release, and adjusting the process window for a mix of large and small components on one board
- Reflow temperature profile; this profile includes preheat, reflow (in which the board is heated to the peak temperature) and cooling down. It is imperative that the peak temperature is high enough for the solder to make reliable solder joints (a solder paste characteristic). In addition, the peak temperature must be low enough that the packages and/or boards are not damaged. The peak temperature of the package depends on package thickness and volume and is classified in accordance with [Table 40](#) and [41](#)

Table 40. SnPb eutectic process (from J-STD-020C)

Package thickness (mm)	Package reflow temperature (°C)	
	Volume (mm ³)	
	< 350	≥ 350
< 2.5	235	220
≥ 2.5	220	220

Table 41. Lead-free process (from J-STD-020C)

Package thickness (mm)	Package reflow temperature (°C)		
	Volume (mm ³)		
	< 350	350 to 2000	> 2000
< 1.6	260	260	260
1.6 to 2.5	260	250	245
> 2.5	250	245	245

Moisture sensitivity precautions, as indicated on the packing, must be respected at all times.

Studies have shown that small packages reach higher temperatures during reflow soldering, see [Figure 63](#).

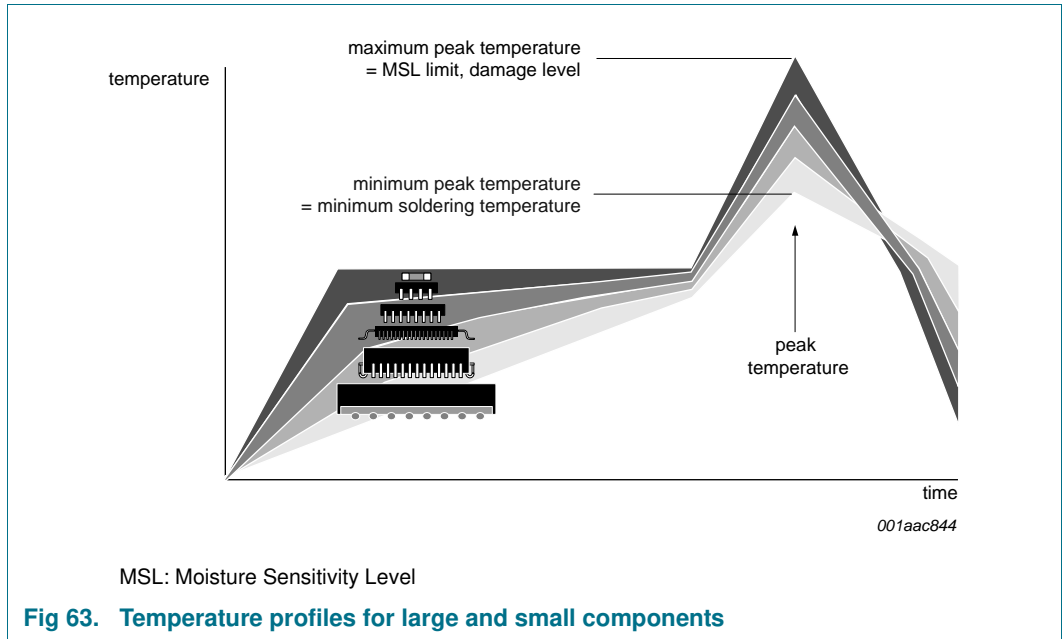

For further information on temperature profiles, refer to Application Note AN10365 “Surface mount reflow soldering description”.

17. Abbreviations

Table 42. Abbreviations

Acronym	Description
AEC	Automotive Electronics Council
CMOS	Complementary Metal Oxide Semiconductor
DC	Direct Current
EPROM	Erasable Programmable Read-Only Memory
HBM	Human Body Model
I ² C	Inter-Integrated Circuit bus
IC	Integrated Circuit
LCD	Liquid Crystal Display
LSB	Least Significant Bit
MSB	Most Significant Bit
MSL	Moisture Sensitivity Level
MUX	Multiplexer
OTP	One Time Programmable
PCB	Printed-Circuit Board
POR	Power-On Reset
RC	Resistance-Capacitance
RAM	Random Access Memory
RMS	Root Mean Square
SCL	Serial Clock Line
SDA	Serial DATA line
SMD	Surface Mount Device
SPI	Serial Peripheral Interface

18. References

- [1] **AN10365** — Surface mount reflow soldering description
- [2] **AN10853** — ESD and EMC sensitivity of IC
- [3] **IEC 60134** — Rating systems for electronic tubes and valves and analogous semiconductor devices
- [4] **IEC 61340-5** — Protection of electronic devices from electrostatic phenomena
- [5] **IPC/JEDEC J-STD-020D** — Moisture/Reflow Sensitivity Classification for Nonhermetic Solid State Surface Mount Devices
- [6] **JESD22-A114** — Electrostatic Discharge (ESD) Sensitivity Testing Human Body Model (HBM)
- [7] **JESD22-C101** — Field-Induced Charged-Device Model Test Method for Electrostatic-Discharge-Withstand Thresholds of Microelectronic Components
- [8] **JESD78** — IC Latch-Up Test
- [9] **JESD625-A** — Requirements for Handling Electrostatic-Discharge-Sensitive (ESDS) Devices
- [10] **NX3-00092** — NXP store and transport requirements
- [11] **SNV-FA-01-02** — Marking Formats Integrated Circuits
- [12] **UM10204** — I²C-bus specification and user manual

19. Revision history

Table 43. Revision history

Document ID	Release date	Data sheet status	Change notice	Supersedes
PCF8537 v.1	20120531	Product data sheet	-	-

20. Legal information

20.1 Data sheet status

Document status ^{[1][2]}	Product status ^[3]	Definition
Objective [short] data sheet	Development	This document contains data from the objective specification for product development.
Preliminary [short] data sheet	Qualification	This document contains data from the preliminary specification.
Product [short] data sheet	Production	This document contains the product specification.

[1] Please consult the most recently issued document before initiating or completing a design.

[2] The term 'short data sheet' is explained in section "Definitions".

[3] The product status of device(s) described in this document may have changed since this document was published and may differ in case of multiple devices. The latest product status information is available on the Internet at URL <http://www.nxp.com>.

20.2 Definitions

Draft — The document is a draft version only. The content is still under internal review and subject to formal approval, which may result in modifications or additions. NXP Semiconductors does not give any representations or warranties as to the accuracy or completeness of information included herein and shall have no liability for the consequences of use of such information.

Short data sheet — A short data sheet is an extract from a full data sheet with the same product type number(s) and title. A short data sheet is intended for quick reference only and should not be relied upon to contain detailed and full information. For detailed and full information see the relevant full data sheet, which is available on request via the local NXP Semiconductors sales office. In case of any inconsistency or conflict with the short data sheet, the full data sheet shall prevail.

Product specification — The information and data provided in a Product data sheet shall define the specification of the product as agreed between NXP Semiconductors and its customer, unless NXP Semiconductors and customer have explicitly agreed otherwise in writing. In no event however, shall an agreement be valid in which the NXP Semiconductors product is deemed to offer functions and qualities beyond those described in the Product data sheet.

20.3 Disclaimers

Limited warranty and liability — Information in this document is believed to be accurate and reliable. However, NXP Semiconductors does not give any representations or warranties, expressed or implied, as to the accuracy or completeness of such information and shall have no liability for the consequences of use of such information. NXP Semiconductors takes no responsibility for the content in this document if provided by an information source outside of NXP Semiconductors.

In no event shall NXP Semiconductors be liable for any indirect, incidental, punitive, special or consequential damages (including - without limitation - lost profits, lost savings, business interruption, costs related to the removal or replacement of any products or rework charges) whether or not such damages are based on tort (including negligence), warranty, breach of contract or any other legal theory.

Notwithstanding any damages that customer might incur for any reason whatsoever, NXP Semiconductors' aggregate and cumulative liability towards customer for the products described herein shall be limited in accordance with the *Terms and conditions of commercial sale* of NXP Semiconductors.

Right to make changes — NXP Semiconductors reserves the right to make changes to information published in this document, including without limitation specifications and product descriptions, at any time and without notice. This document supersedes and replaces all information supplied prior to the publication hereof.

Suitability for use — NXP Semiconductors products are not designed, authorized or warranted to be suitable for use in life support, life-critical or safety-critical systems or equipment, nor in applications where failure or malfunction of an NXP Semiconductors product can reasonably be expected to result in personal injury, death or severe property or environmental damage. NXP Semiconductors and its suppliers accept no liability for inclusion and/or use of NXP Semiconductors products in such equipment or applications and therefore such inclusion and/or use is at the customer's own risk.

Applications — Applications that are described herein for any of these products are for illustrative purposes only. NXP Semiconductors makes no representation or warranty that such applications will be suitable for the specified use without further testing or modification.

Customers are responsible for the design and operation of their applications and products using NXP Semiconductors products, and NXP Semiconductors accepts no liability for any assistance with applications or customer product design. It is customer's sole responsibility to determine whether the NXP Semiconductors product is suitable and fit for the customer's applications and products planned, as well as for the planned application and use of customer's third party customer(s). Customers should provide appropriate design and operating safeguards to minimize the risks associated with their applications and products.

NXP Semiconductors does not accept any liability related to any default, damage, costs or problem which is based on any weakness or default in the customer's applications or products, or the application or use by customer's third party customer(s). Customer is responsible for doing all necessary testing for the customer's applications and products using NXP Semiconductors products in order to avoid a default of the applications and the products or of the application or use by customer's third party customer(s). NXP does not accept any liability in this respect.

Limiting values — Stress above one or more limiting values (as defined in the Absolute Maximum Ratings System of IEC 60134) will cause permanent damage to the device. Limiting values are stress ratings only and (proper) operation of the device at these or any other conditions above those given in the Recommended operating conditions section (if present) or the Characteristics sections of this document is not warranted. Constant or repeated exposure to limiting values will permanently and irreversibly affect the quality and reliability of the device.

Terms and conditions of commercial sale — NXP Semiconductors products are sold subject to the general terms and conditions of commercial sale, as published at <http://www.nxp.com/profile/terms>, unless otherwise agreed in a valid written individual agreement. In case an individual agreement is concluded only the terms and conditions of the respective agreement shall apply. NXP Semiconductors hereby expressly objects to applying the customer's general terms and conditions with regard to the purchase of NXP Semiconductors products by customer.

No offer to sell or license — Nothing in this document may be interpreted or construed as an offer to sell products that is open for acceptance or the grant, conveyance or implication of any license under any copyrights, patents or other industrial or intellectual property rights.

Export control — This document as well as the item(s) described herein may be subject to export control regulations. Export might require a prior authorization from competent authorities.

Non-automotive qualified products — Unless this data sheet expressly states that this specific NXP Semiconductors product is automotive qualified, the product is not suitable for automotive use. It is neither qualified nor tested in accordance with automotive testing or application requirements. NXP Semiconductors accepts no liability for inclusion and/or use of non-automotive qualified products in automotive equipment or applications.

In the event that customer uses the product for design-in and use in automotive applications to automotive specifications and standards, customer (a) shall use the product without NXP Semiconductors' warranty of the product for such automotive applications, use and specifications, and (b) whenever customer uses the product for automotive applications beyond NXP Semiconductors' specifications such use shall be solely at customer's

own risk, and (c) customer fully indemnifies NXP Semiconductors for any liability, damages or failed product claims resulting from customer design and use of the product for automotive applications beyond NXP Semiconductors' standard warranty and NXP Semiconductors' product specifications.

Translations — A non-English (translated) version of a document is for reference only. The English version shall prevail in case of any discrepancy between the translated and English versions.

20.4 Trademarks

Notice: All referenced brands, product names, service names and trademarks are the property of their respective owners.

I²C-bus — logo is a trademark of NXP B.V.

21. Contact information

For more information, please visit: <http://www.nxp.com>

For sales office addresses, please send an email to: salesaddresses@nxp.com

22. Tables

Table 1. Ordering information	2	Table 40. SnPb eutectic process (from J-STD-020C)	72
Table 2. Marking codes	2	Table 41. Lead-free process (from J-STD-020C)	72
Table 3. Pin description of PCF8537AH and PCF8537BH	6	Table 42. Abbreviations	74
Table 4. Commands of PCF8537	7	Table 43. Revision history	76
Table 5. Initialize - initialize command bit description	8		
Table 6. OTP-refresh - OTP-refresh command bit description	8		
Table 7. Oscillator-ctrl - oscillator control command bit description	8		
Table 8. Charge-pump-ctrl - charge pump control command bit description	9		
Table 9. Temp-msr-ctrl - temperature measurement control command bit description	10		
Table 10. Temp-comp - temperature compensation coefficients command	10		
Table 11. Set-VPR - set VPR command bit description	11		
Table 12. Display-enable - display enable command bit description	11		
Table 13. Set-MUX-mode - set multiplex drive mode command bit description	12		
Table 14. Set-bias-mode - set bias mode command bit description	12		
Table 15. Load-data-pointer - load data pointer command bit description	12		
Table 16. Frame frequency - frame frequency and output clock frequency command bit description	13		
Table 17. Frame frequency values	13		
Table 18. Bank-select - bank select command bit description	14		
Table 19. Write-RAM-data - write RAM data command bit description	14		
Table 20. Temp-read - temperature readout command bit description	15		
Table 21. Invmode_ctrl - drive scheme inversion command bit description	15		
Table 22. Temp-filter - digital temperature filter command bit description	16		
Table 23. Reset state	17		
Table 24. Selection of display configurations	23		
Table 25. Temperature measurement update rate	28		
Table 26. Temperature coefficients.	30		
Table 27. Calculation of the V_{LCD} offset voltage.	31		
Table 28. LCD drive modes: summary of characteristics	32		
Table 29. Mapping of output pins and corresponding signals with respect to driving mode.	42		
Table 30. Control byte description	52		
Table 31. I ² C slave address byte	55		
Table 32. R/W bit description	55		
Table 33. Serial interface	57		
Table 34. Subaddress byte definition	57		
Table 35. Limiting values	61		
Table 36. Static characteristics	62		
Table 37. Dynamic characteristics	67		
Table 38. Timing characteristics: I ² C-bus	68		
Table 39. Timing characteristics: SPI-bus	69		

23. Figures

Fig 1. Block diagram of PCF8537AH.	3	with $\frac{1}{3}$ bias (line inversion mode)	36
Fig 2. Block diagram of PCF8537BH.	4	Fig 27. Waveforms for the 1:4 multiplex drive mode	
Fig 3. Pin configuration for TQFP64 (PCF8537AH).	5	with $\frac{1}{3}$ bias (line inversion mode)	37
Fig 4. Pin configuration for TQFP64 (PCF8537BH).	5	Fig 28. Waveforms for 1:6 multiplex drive mode	
Fig 5. Recommended start-up sequence when using		with $\frac{1}{3}$ bias (line inversion mode)	38
the internal charge pump and the internal clock		Fig 29. Waveforms for 1:6 multiplex drive mode	
signal	18	with $\frac{1}{4}$ bias (line inversion mode)	39
Fig 6. Recommended start-up sequence when using		Fig 30. Waveforms for 1:8 multiplex drive mode	
an external supplied V_{LCD} and the internal clock		with $\frac{1}{4}$ bias (line inversion mode)	40
signal	19	Fig 31. Waveforms for 1:8 multiplex drive mode	
Fig 7. Recommended start-up sequence when using the		with $\frac{1}{4}$ bias (frame inversion mode)	41
internal charge pump and an external clock		Fig 32. Display RAM bitmap	45
signal	19	Fig 33. Display RAM filling order in static drive mode.	47
Fig 8. Recommended start-up sequence when using		Fig 34. Discarded bits at the end of data transmission	47
an external supplied V_{LCD} and an external		Fig 35. Display RAM filling order in 1:2 multiplex drive	
clock signal	20	mode	47
Fig 9. Recommended power-down sequence for		Fig 36. Display RAM filling order in 1:4 multiplex drive	
minimum power-down current when using the		mode	48
internal charge pump and the internal clock		Fig 37. Display RAM filling order in 1:6 multiplex drive	
signal	20	mode	49
Fig 10. Recommended power-down sequence when		Fig 38. Display RAM filling order in 1:8 multiplex drive	
using an external supplied V_{LCD} and the internal		mode	49
clock signal	21	Fig 39. Bank selection.	50
Fig 11. Recommended power-down sequence when		Fig 40. Example of the Bank-select command with	
using the internal charge pump and an external		multiplex drive mode 1:4	50
clock signal	21	Fig 41. Control byte format	52
Fig 12. Recommended power-down sequence for		Fig 42. Bit transfer.	53
minimum power-down current when using an		Fig 43. Definition of START and STOP conditions	53
external supplied V_{LCD} and an external clock		Fig 44. System configuration.	54
signal	22	Fig 45. Acknowledgement on the I ² C-bus.	54
Fig 13. Example of displays suitable for PCF8537	23	Fig 46. I ² C-bus protocol, write mode.	56
Fig 14. Typical I ² C system configuration when using		Fig 47. I ² C-bus protocol, read mode.	56
the internal V_{LCD} generation	24	Fig 48. Data transfer overview	57
Fig 15. Typical SPI system configuration when using		Fig 49. SPI-bus write example	58
an external V_{LCD}	24	Fig 50. SPI-bus write example	58
Fig 16. V_{LCD} generation including temperature		Fig 51. SPI-bus read example.	59
compensation	25	Fig 52. Device protection diagram for PCF8537AH	60
Fig 17. V_{LCD} programming of PCF8537 (assuming		Fig 53. Device protection diagram for PCF8537BH	60
$VT[7:0] = 0h$)	26	Fig 54. LCD voltage variation with respect to	
Fig 18. Charge pump driving capability with		temperature	64
$V_{DD2} = 3.3 V$	27	Fig 55. Typical I_{DD1} with respect to temperature	65
Fig 19. Charge pump driving capability with		Fig 56. Typical I_{DD2} with respect to temperature	65
$V_{DD2} = 5.0 V$	28	Fig 57. Typical $I_{DD(LCD)}$ with respect to temperature	66
Fig 20. Temperature measurement block with digital		Fig 58. Driver timing waveforms	67
temperature filter	29	Fig 59. RESET timing	67
Fig 21. Temperature measurement delay during		Fig 60. I ² C-bus timing waveforms	68
ramping up-down of the environment		Fig 61. SPI-bus timing.	69
temperature	29	Fig 62. Package outline SOT357-1 (TQFP64)	70
Fig 22. Example of segmented temperature coefficients.	30	Fig 63. Temperature profiles for large and small	
Fig 23. Electro-optical characteristic: relative		components.	73
transmission curve of the liquid	33		
Fig 24. Static drive mode waveforms (line inversion			
mode).	34		
Fig 25. Waveforms for the 1:2 multiplex drive mode			
with $\frac{1}{2}$ bias (line inversion mode)	35		
Fig 26. Waveforms for the 1:2 multiplex drive mode			

24. Contents

1	General description	1	8.4.4.1	Temperature readout	28
2	Features and benefits	1	8.4.4.2	Temperature adjustment of the V_{LCD}	30
3	Applications	2	8.4.5	LCD voltage selector	31
4	Ordering information	2	8.4.5.1	Electro-optical performance	33
5	Marking	2	8.4.6	LCD drive mode waveforms	34
6	Block diagram	3	8.4.6.1	Static drive mode	34
7	Pinning information	5	8.4.6.2	1:2 multiplex drive mode	35
7.1	Pinning	5	8.4.6.3	1:4 multiplex drive mode	37
7.2	Pin description	6	8.4.6.4	1:6 multiplex drive mode	38
8	Functional description	7	8.4.6.5	1:8 multiplex drive mode	40
8.1	Commands of PCF8537	7	8.5	Backplane and segment outputs	42
8.1.1	Command: Initialize	8	8.5.1	Backplane outputs	42
8.1.2	Command: OTP-refresh	8	8.5.1.1	1:8 multiplex drive mode	42
8.1.3	Command: Oscillator-ctrl	8	8.5.1.2	1:6 multiplex drive mode	42
8.1.3.1	Oscillator	8	8.5.1.3	1:4 multiplex drive mode	42
8.1.3.2	Internal oscillator	9	8.5.1.4	1:2 multiplex drive mode	42
8.1.3.3	External clock	9	8.5.1.5	Static drive mode	43
8.1.4	Command: Charge-pump-ctrl	9	8.5.2	Segment outputs	43
8.1.5	Command: Temp-msr-ctrl	10	8.5.2.1	Static, 1:8, 1:4, 1:2 multiplex drive mode	43
8.1.6	Command: Temp-comp	10	8.5.2.2	1:6 multiplex drive mode	43
8.1.7	Command: Set-VPR	11	8.6	Display controller	44
8.1.8	Command: Display-enable	11	8.7	Display register	44
8.1.9	Command: Set-MUX-mode	12	8.8	Display RAM	44
8.1.10	Command: Set-bias-mode	12	8.8.1	Data pointer	46
8.1.11	Command: Load-data-pointer	12	8.8.2	RAM filling in static drive mode	47
8.1.12	Command: Frame-frequency	13	8.8.3	RAM filling in 1:2 multiplex drive mode	47
8.1.12.1	Timing and frame frequency	14	8.8.4	RAM filling in 1:4 multiplex drive mode	48
8.1.13	Command: Bank-select	14	8.8.5	RAM filling in 1:6 multiplex drive mode	48
8.1.14	Command: Write-RAM-data	14	8.8.6	RAM filling in 1:8 multiplex drive mode	49
8.1.15	Command: Temp-read	15	8.9	Bank selection	50
8.1.16	Command: Invmode_ctrl	15	8.9.1	Input bank selection	50
8.1.17	Command: Temp-filter	16	8.9.2	Output bank selection	51
8.2	Start-up and shut-down	17	9	Bus interfaces	52
8.2.1	Power-On Reset (POR)	17	9.1	Control byte	52
8.2.2	RESET pin function	18	9.2	I ² C-bus interface characteristics (PCF8537AH)	53
8.2.3	Recommended start-up sequences	18	9.2.1	Bit transfer	53
8.2.4	Recommended sequences to enter power-down mode	20	9.2.2	START and STOP conditions	53
8.3	Possible display configurations	23	9.2.3	System configuration	53
8.4	LCD supply voltage	25	9.2.4	Acknowledge	54
8.4.1	External V_{LCD} supply	25	9.2.5	I ² C-bus controller	54
8.4.2	Internal V_{LCD} generation	25	9.2.6	Input filters	55
8.4.3	Charge pump	26	9.2.7	I ² C-bus slave address	55
8.4.3.1	Charge pump configuration	26	9.2.8	I ² C-bus protocol	55
8.4.3.2	Charge pump driving capability	26	9.2.9	Data read	56
8.4.4	Temperature measurement and temperature compensation of V_{LCD}	28	9.3	SPI-bus interface (PCF8537BH)	57
			9.3.1	Data transmission	57
			9.3.2	Data read	58

continued >>

10 Internal circuitry..... 60

11 Limiting values..... 61

12 Static characteristics..... 62

13 Dynamic characteristics..... 67

14 Package outline..... 70

15 Handling information..... 71

16 Soldering of SMD packages..... 71

16.1 Introduction to soldering..... 71

16.2 Wave and reflow soldering..... 71

16.3 Wave soldering..... 72

16.4 Reflow soldering..... 72

17 Abbreviations..... 74

18 References..... 75

19 Revision history..... 76

20 Legal information..... 77

20.1 Data sheet status..... 77

20.2 Definitions..... 77

20.3 Disclaimers..... 77

20.4 Trademarks..... 78

21 Contact information..... 78

22 Tables..... 79

23 Figures..... 80

24 Contents..... 81

Please be aware that important notices concerning this document and the product(s) described herein, have been included in section 'Legal information'.

© NXP B.V. 2012.

All rights reserved.

For more information, please visit: <http://www.nxp.com>

For sales office addresses, please send an email to: salesaddresses@nxp.com

Date of release: 31 May 2012

Document identifier: PCF8537