

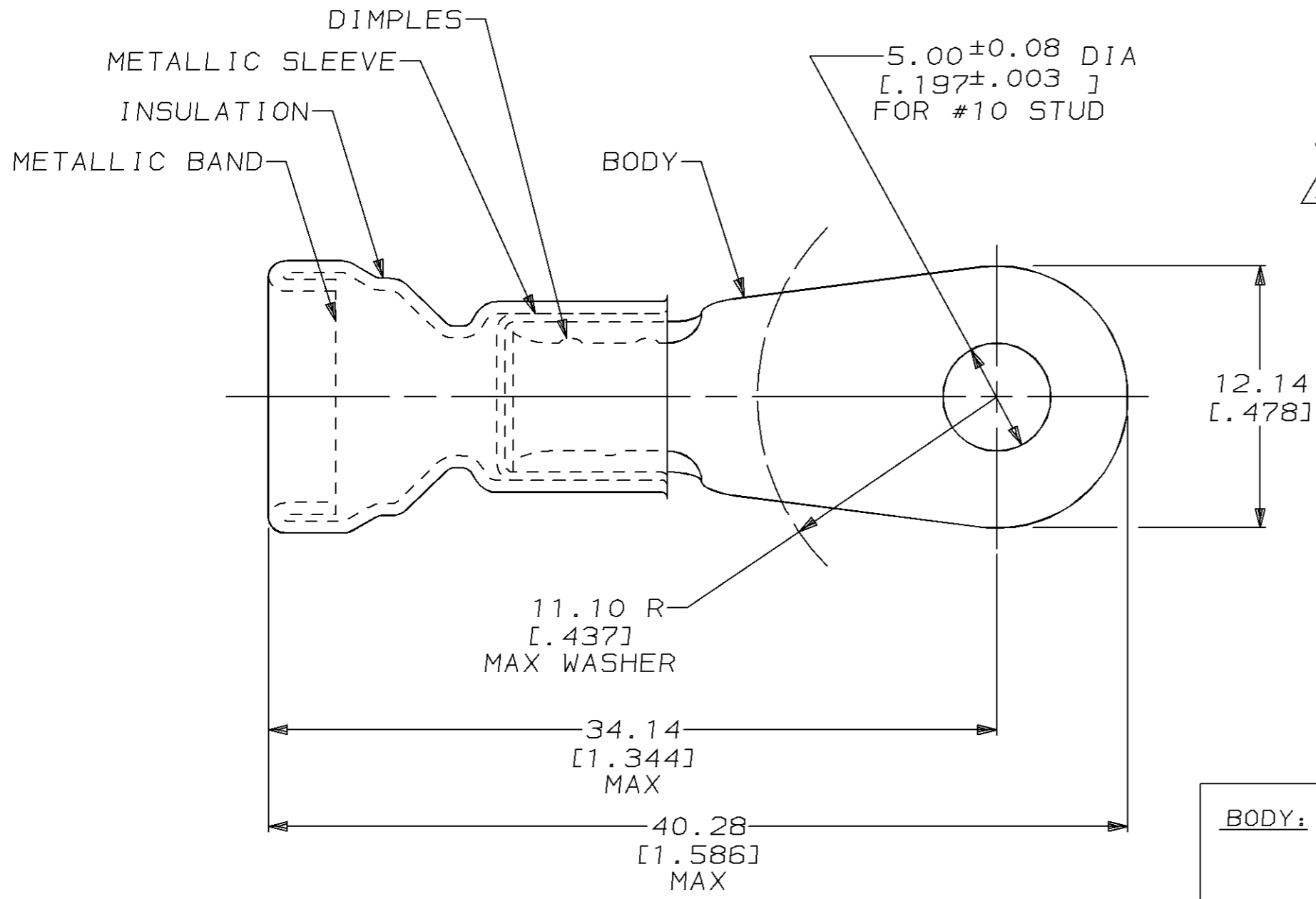

THIS DRAWING IS UNPUBLISHED. RELEASED FOR PUBLICATION ,19 .
 © COPYRIGHT 19 BY AMP INCORPORATED. ALL RIGHTS RESERVED.

LOC		DIST		REVISIONS			
P	LTR	DESCRIPTION	DATE	DWN	APVD		
G	14	F	REVISD & REDRAWN PER 0720-0921-96	10MAY96	DKS	DMS	



- 1 MATERIAL THK: 1.02 ± 0.08 [0.040 ± 0.003]
- 2 WIRE INSULATION DIA: 7.57 [0.298] MAX
- 3 TAPE MOUNTED PER 115-11001

<u>BODY:</u> COPPER PER ASTM B-152 TIN PL 0.00254 [0.00100] MIN THK PER MIL-T-10727	 2-322048-2 OBSOLETE
<u>INSULATION:</u> PVC COLOR: RED <u>METALLIC SLEEVE:</u> COPPER PER ASTM B-152 <u>METALLIC BAND:</u> STEEL PER ASTM A-109	
MATERIAL & FINISH	AMP PART NUMBER

AMP INCORPORATED CUSTOMER SERVICE SYSTEMS

FOR ADDITIONAL PRODUCT INFORMATION OR COPIES OF DRAWINGS AND TECHNICAL DOCUMENTS	PRODUCT INFORMATION CENTER 1-800-522-6752	RECOMMENDED OPERATING TEMPERATURE: 105°C MAX
FOR APPLICATION TOOLING INFORMATION	TOOLING ASSISTANCE CENTER 1-800-722-1111	VOLTAGE RATING: NOT APPLICABLE
FOR ORDER ENTRY	1-800-526-5142	WIRE CROSS SECTIONAL AREA RANGE: SOLID OR STRANDED

THIS DRAWING IS A CONTROLLED DOCUMENT FOR AMP INCORPORATED. IT IS SUBJECT TO CHANGE AND THE CONTROLLING ENGINEERING ORGANIZATION SHOULD BE CONTACTED FOR THE LATEST REVISION.

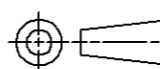
DIMENSIONS:	TOLERANCES UNLESS OTHERWISE SPECIFIED.
mm [INCHES]	
	0 PLC ±-
	1 PLC ±-
	2 PLC ±0.20 [0.008]
	3 PLC ±-
	4 PLC ANGLES ±-
MATERIAL	FINISH
SEE TABLE	SEE TABLE

DWN DK SCHRUM 10MAY96	 AMP Incorporated Harrisburg, PA 17105-3608
CHK DM SWARTZ 13MAY96	
APVD JL MECKLEY 13MAY96	
PRODUCT SPEC	NAME TERMINAL, RING TONGUE, AMPLI-BOND™, WIRE SIZE: 8 AWG
APPLICATION SPEC	SIZE A3
WEIGHT	CAGE CODE 00779
CUSTOMER DRAWING	DRAWING NO C-322048
	SCALE 4:1
	SHEET 1 OF 1
	REV F