

LOC	DIST	REV	DATE	BY	APPV
-	-	B	11-26-19	CT	DM

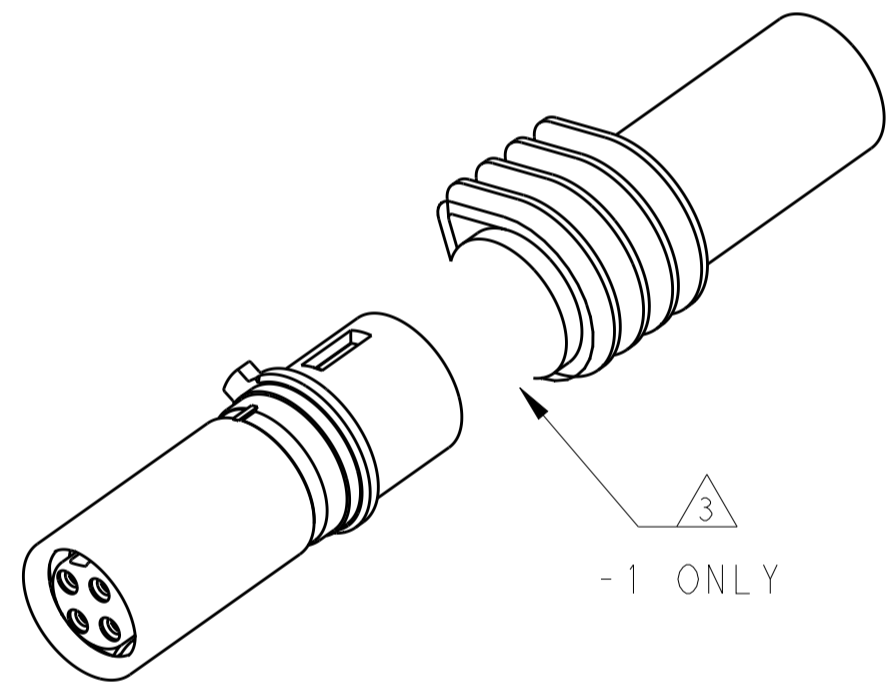
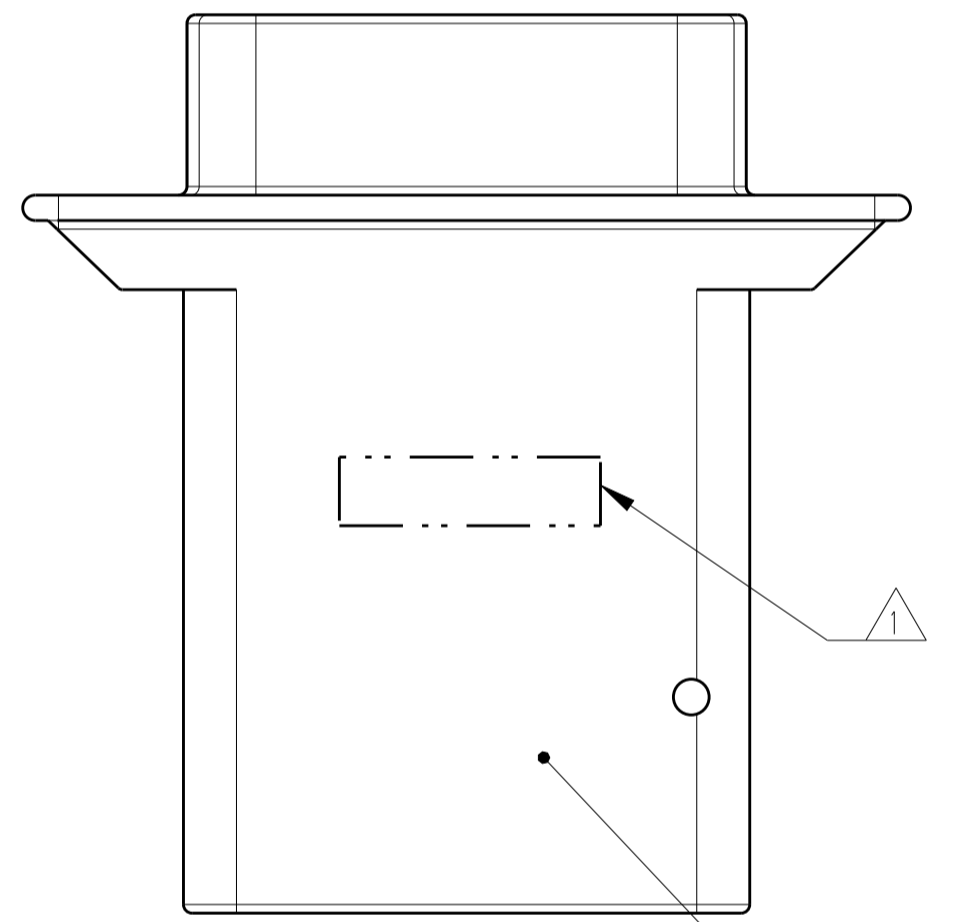
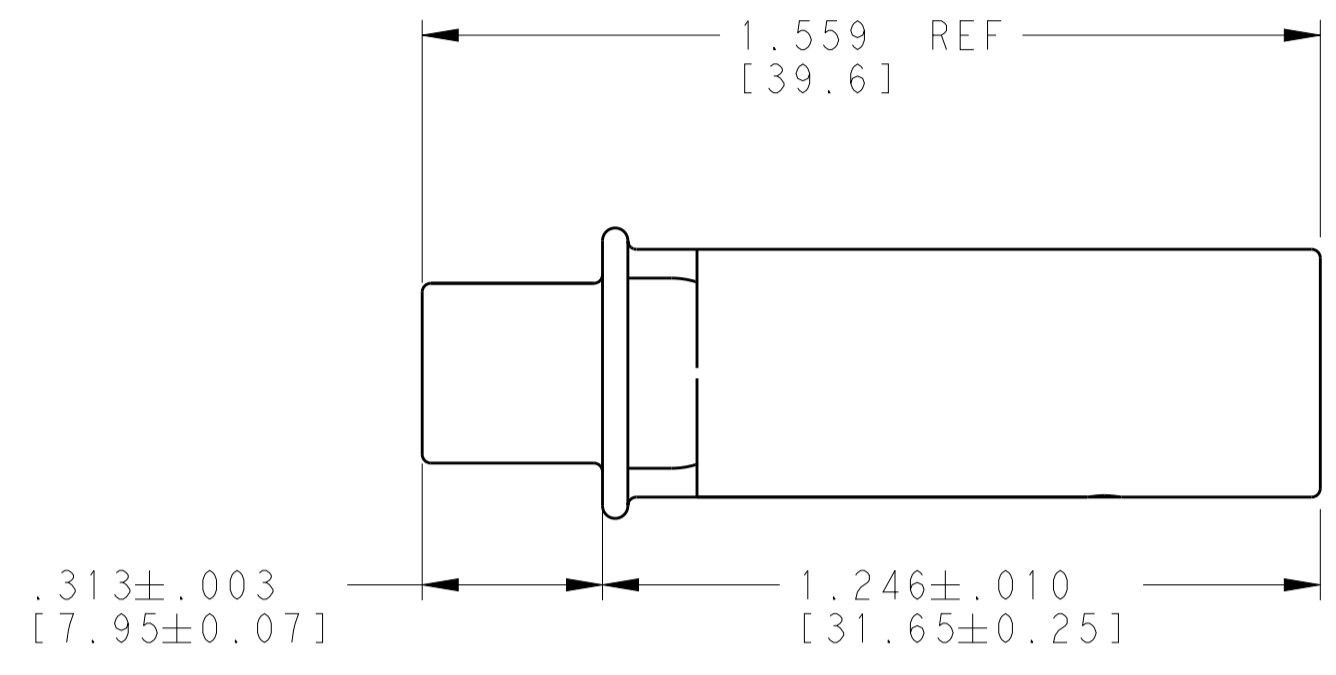
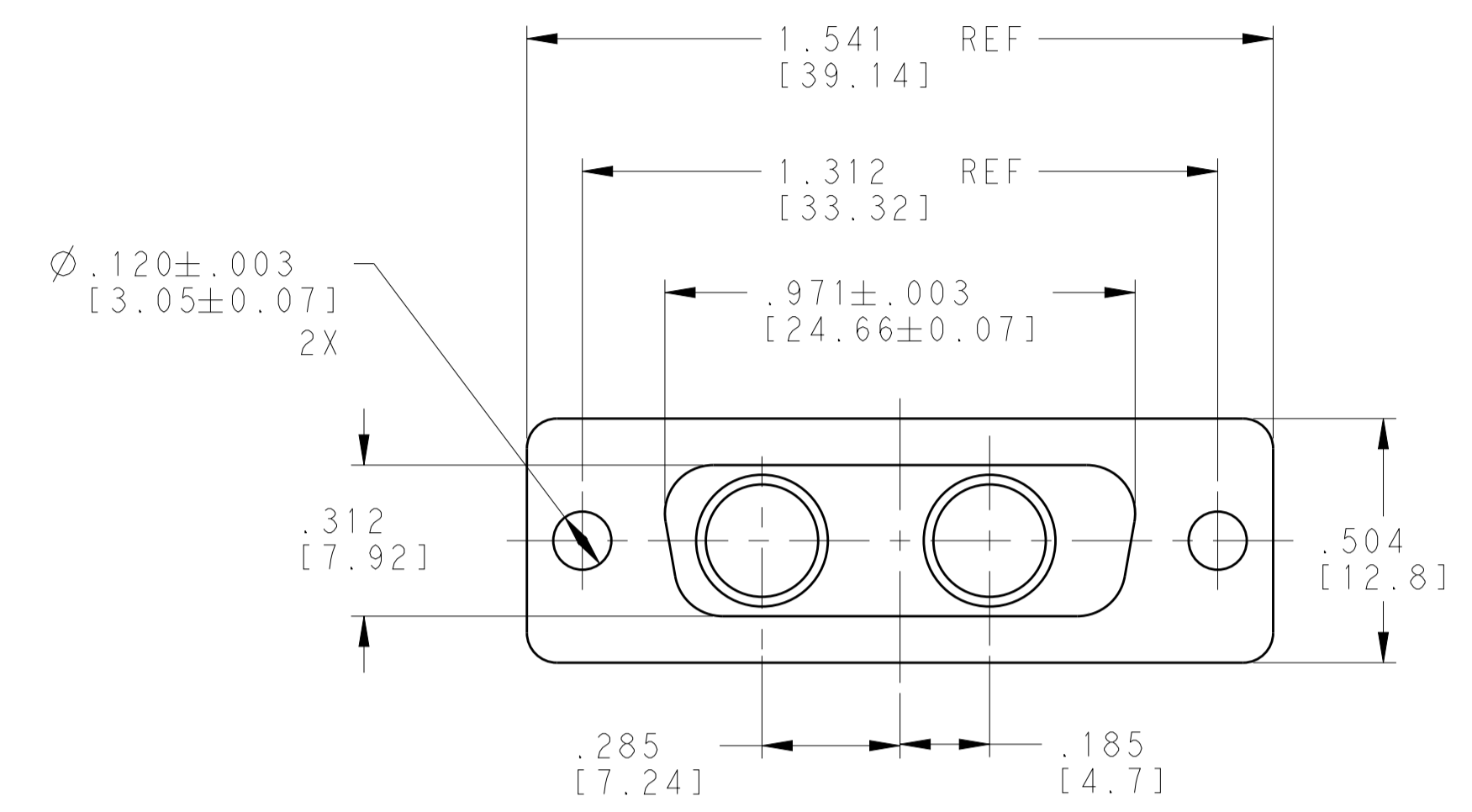
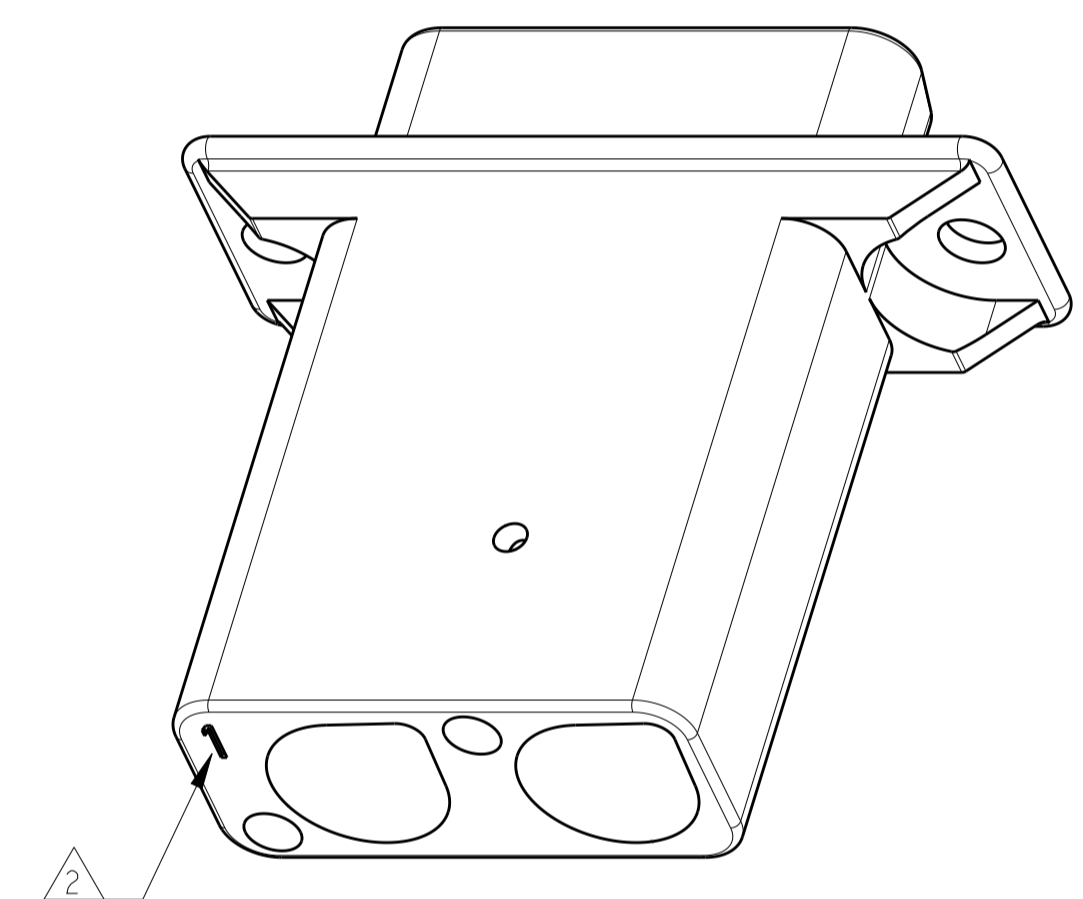
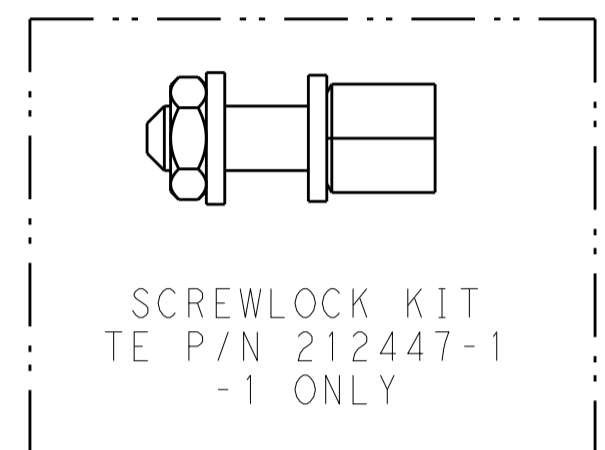
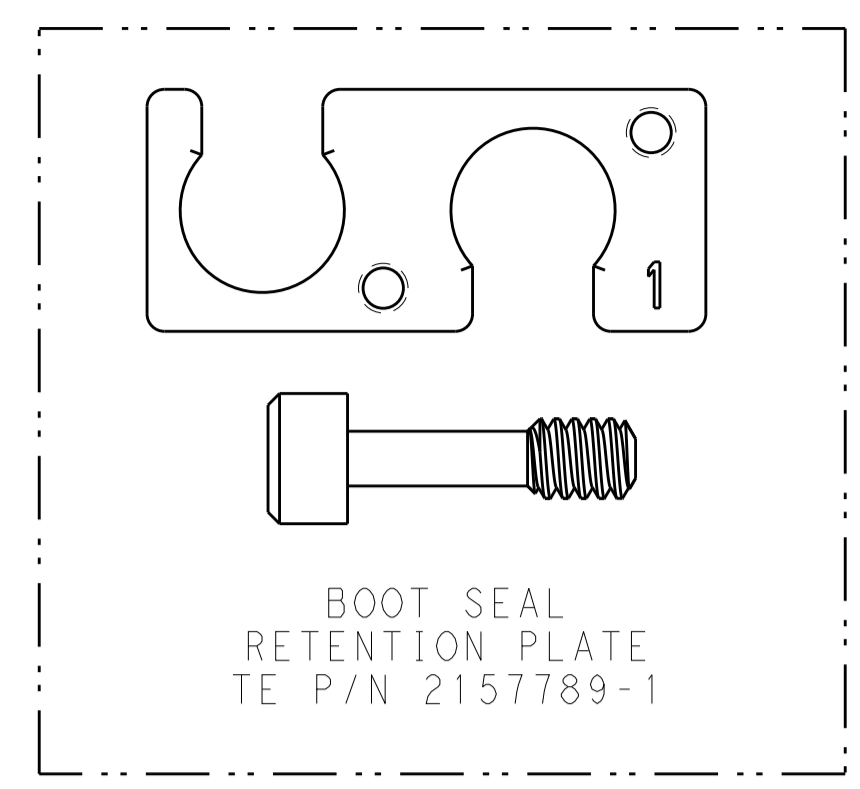

SHELL
 ELECTROLESS NICKEL PLATED PER AMS-C-26074 CLASS 1
 ALUMINUM ALLOY 6061-T6 PER ASTM B221
 CONTACT RETENTION CLIP QTY = 2 (ASSEMBLED INSIDE SHELL)
 STAINLESS STEEL PER UNS S30200 PER ASTM A666
 PLATED SILVER .000400 MIN THICK PER ASTM B700 OVER WOODS
 NICKEL STRIKE PER ASTM B254

- ① CONNECTOR IS MARKED WITH TE PART NO., TE LOGO OR TE, CAGE CODE & DATE CODE IN APPROXIMATE AREA SHOWN. (EITHER SIDE)
- ② RECESSED CIRCUIT IDENTIFICATION.
- ③ QUADRAX SOCKET ASSEMBLY SUPPLIED UNASSEMBLED TO SHELL.

2157789-1	--	--	2294317-2
2157789-1	212447-1	1445693-3	2294317-1
BOOT SEAL RETENTION KIT QTY = 1	SCREWLOCK KIT QTY = 1	CONTACT QTY = 2	ASSEMBLY PART NO

DIMENSIONS:		TOLERANCES UNLESS OTHERWISE SPECIFIED:		APPROVED:		NAME:	
[INCHES(mm)]		0 PLC	±	DWN	C.C. THOMAS	7-24-15	TE Connectivity PLUG ASSEMBLY, LOW PROFILE, 202 RECTANGULAR QUADRAX KIT, SIZE 2 W/RETENTION PLATE AND SCREWLOCKS
		1 PLC	±	CHK	D. MILLER	7-24-15	
		2 PLC	±	APV	D. MILLER	7-24-15	
		3 PLC	±	APPLICATION SPEC		SIZE	
		4 PLC	±	MATERIAL		CAGE CODE	DRAWING NO
		ANGLES	±	FINISH		RESTRICTED TO	
				WEIGHT		A100779	©=2294317
				CUSTOMER DRAWING		SCALE	3:1
						SHEET	1 OF 1
						REV	B