



Hologen Free

SM1608A Series



1. Features of SM1608A series:

- Molded Inductor in 4.75 x 4.45mm foot print.
- High saturation current from distributed gap metal dust core.
- Low profile: 2.00mm Max. Height.
- Ideal for DC/DC converters, PDA, Notebook and Server Application.
- Operating Temperature Range: -55°C to 125°C (ambient + self-temperature rise) .
- T & R Qty's: 3000 pcs , 13" Reel and Plastic tape: 12mm wide, 8mm pocket spacing.
- RoHS and HF compliant.



2. Electrical Characteristics of SM1608A series:

ITG Part Number	Inductance(OCL) ¹ (uH) ± 20%	DCR (mΩ) Typ. @25°C	DCR (mΩ) Max. @25°C	Isat ² (A) @25°C	Irms ³ (A) @25°C	Marking
SM1608A-R020MHF	0.020+20%/-30%	0.355	0.43	78.00	40.00	20A
SM1608A-R10MHF	0.10	3.65	4.20	22.00	13.00	R10
SM1608A-R18MHF	0.18	4.50	5.20	21.00	13.00	R18
SM1608A-R22MHF	0.22	5.00	5.80	12.50	9.50	R22
SM1608A-R33MHF	0.33	7.10	8.20	12.00	9.00	R33
SM1608A-R47MHF	0.47	10.50	12.00	9.50	7.50	R47
SM1608A-R56MHF	0.56	10.90	12.55	9.50	7.30	R56
SM1608A-R68MHF	0.68	11.70	13.50	9.00	7.00	R68
SM1608A-1R0MHF	1.00	19.20	22.00	7.00	6.00	1R0
SM1608A-1R2MHF	1.20	23.00	26.50	7.00	6.00	1R2
SM1608A-1R5MHF	1.50	25.30	29.00	5.50	5.00	1R5
SM1608A-2R2MHF	2.20	40.20	46.00	5.00	4.50	2R2
SM1608A-3R3MHF	3.30	70.60	81.00	4.00	3.30	3R3
SM1608A-4R7MHF	4.70	103.40	114.00	3.00	2.80	4R7
SM1608A-6R8MHF	6.80	162.80	179.00	2.50	2.40	6R8
SM1608A-100MHF	10.00	256.30	282.00	2.00	1.60	100
SM1608A-220MHF	22.00	330.00	363.00	1.65	1.25	220

3. Mechanical Dimensions of SM1608A series (unit: mm):

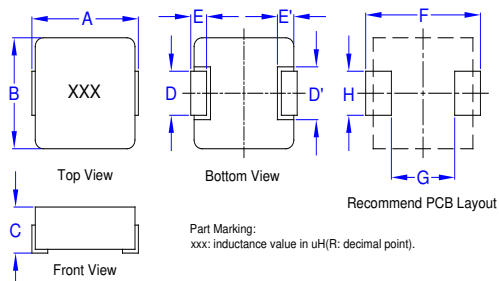

Pad Dimension	SM1608A
F	5.20
G	2.20
H	2.50

Type	A	B	C	D	D'	E	E'
SM1608A	4.40 ± 0.35	4.20 ± 0.25	1.80 ± 0.20	1.50 ± 0.30	2.50 ± 0.20	0.80 ± 0.30	1.00 ± 0.10

Notes:

1. Test conditions: 100KHz, 1.0V, 25°C ambient temperature .
2. Isat: DC current that causes inductance to drop 30% (Typ.) from OCL (Ta=25°C).
3. Irms: DC current for an approximate temperature rise of 40°C without core loss. Derating is necessary for AC currents. PCB pad layout, trace thickness and width, air-flow and proximity of other heat generating components will affect the temperature rise. It is recommended the part temperature not exceed 125° C under worst case operating conditions as verified in the end application.

● New York 1 914 347 2474 ● Taipei 886 2 2698 8669 ● Kaohsiung 886 7 350 2275
 ● Japan 81 568 85 2830 ● Shenzhen 86 755 8418 6263 ● Shanghai 86 21 5424 5141 ● Hong Kong 852 9688 9767
 ● sales@ITG-Electronics.com ● www.ITG-Electronics.com Revision C.2: April 12 , 2022

*Due to continuous product improvement, all specifications are subject to change without prior notice. Kindly contact an ITG field application engineer or a sales representative prior to purchase.



Hologen Free

SM1608A Series



4. Inductance vs. Current vs. Temperature Rise Characteristics of SM1608A Series :

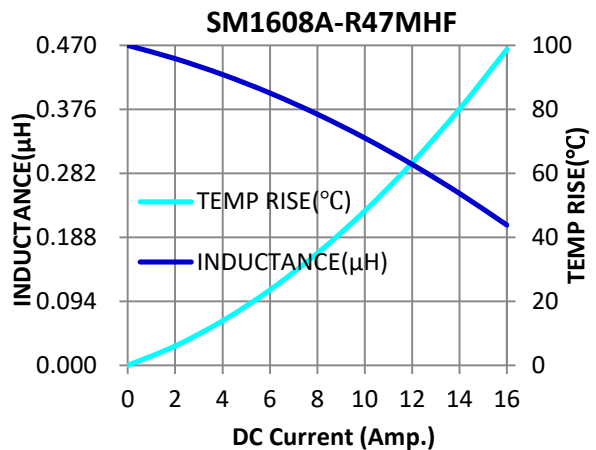
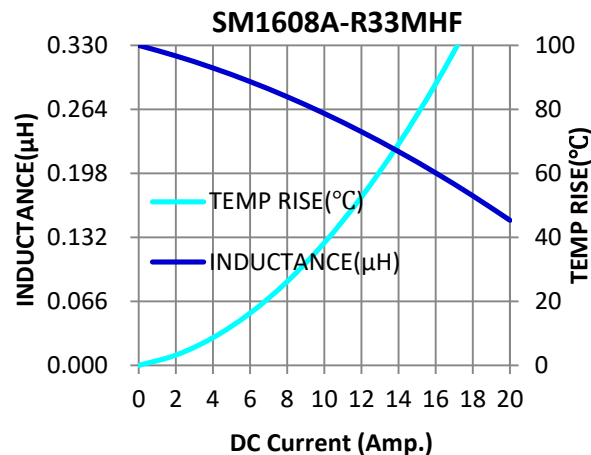
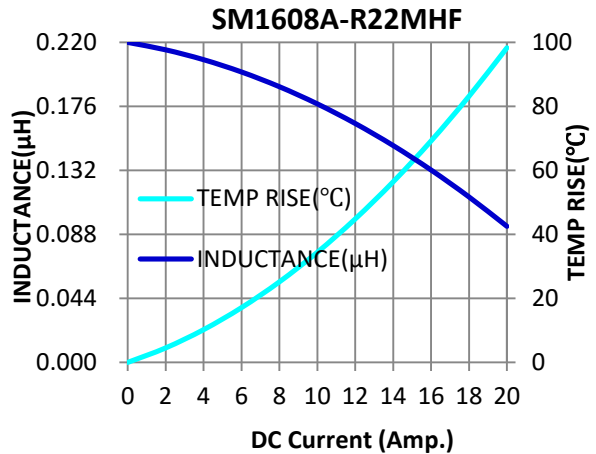
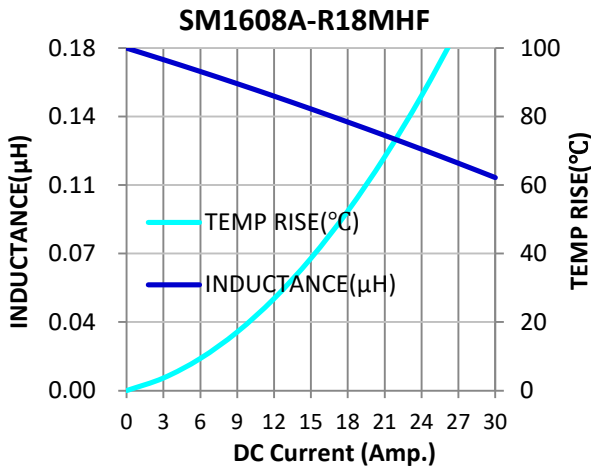
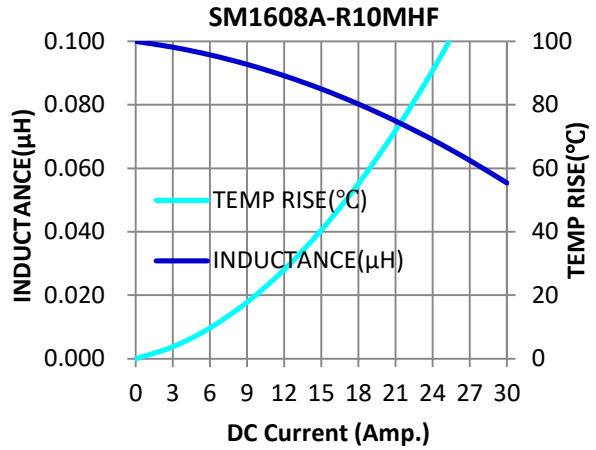
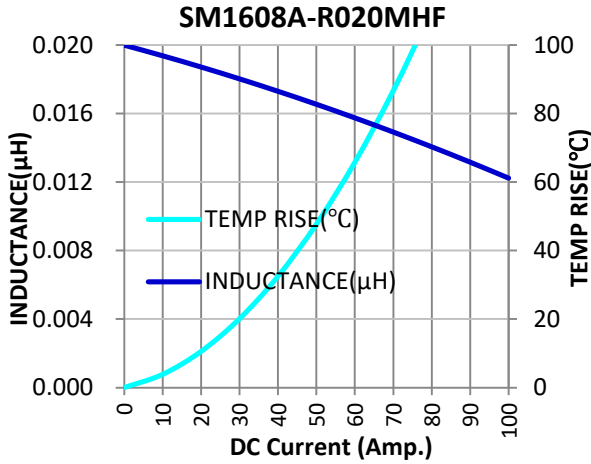



Halogen Free

SM1608A Series



4. Inductance vs. Current vs. Temperature Rise Characteristics of SM1608A Series :

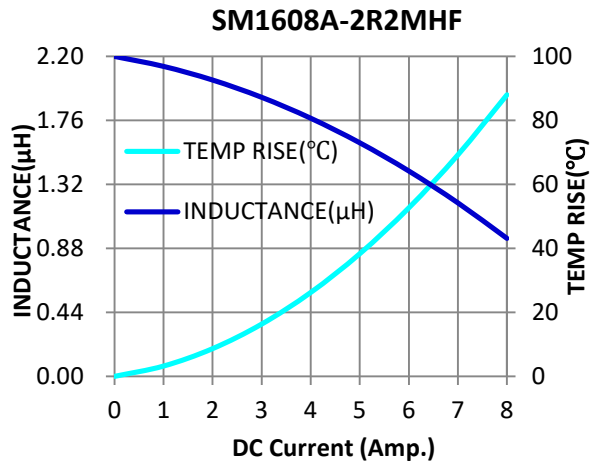
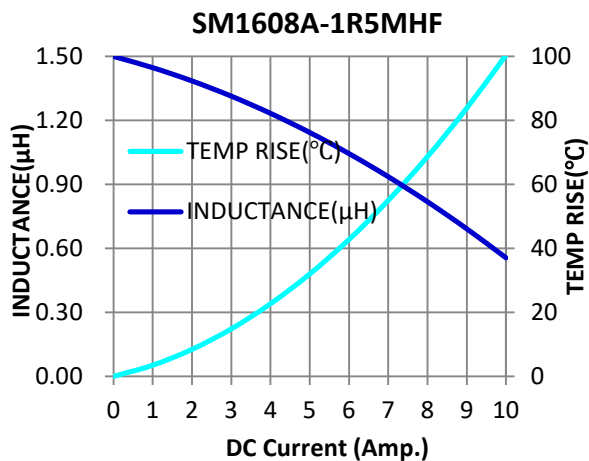
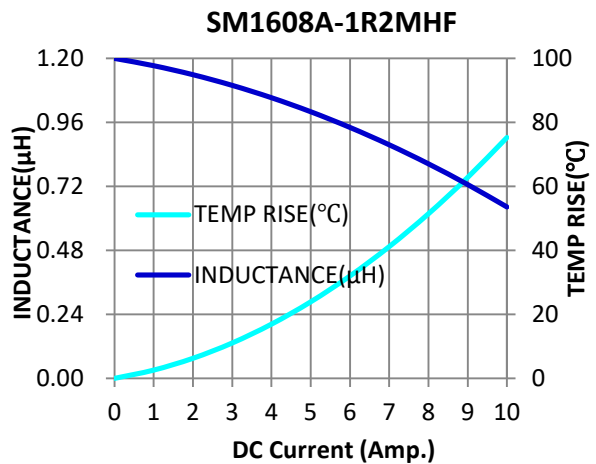
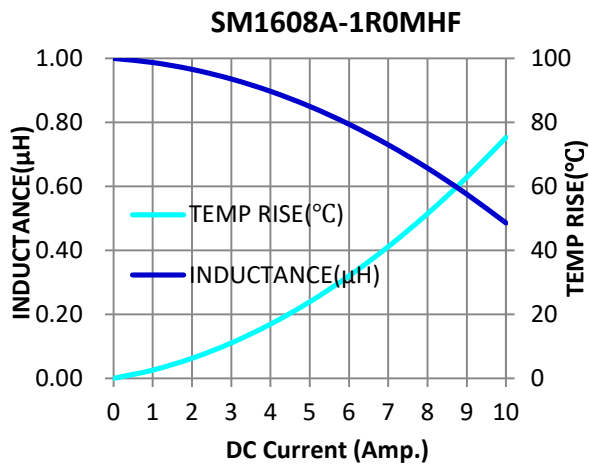
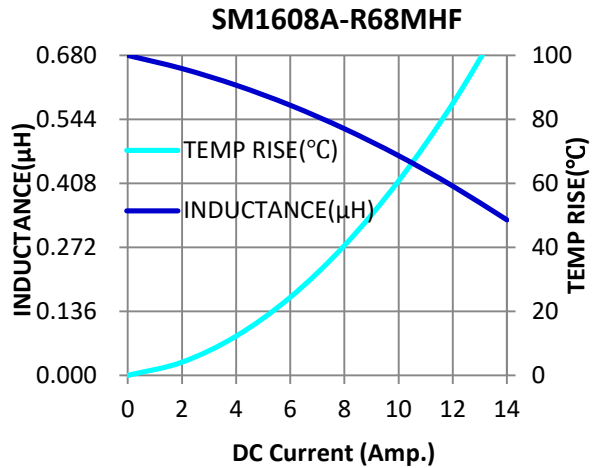
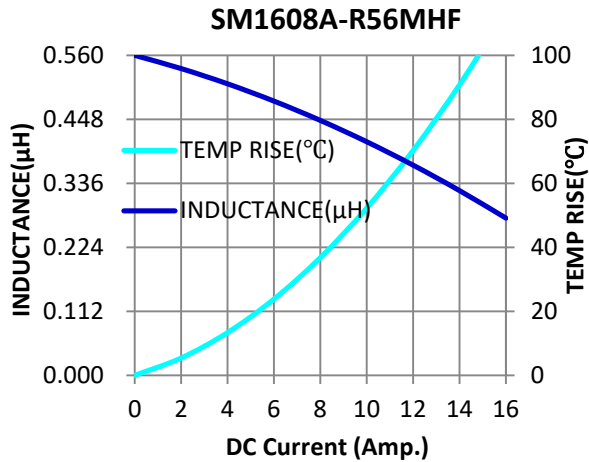

● New York 1 914 347 2474 ● Taipei 886 2 2698 8669 ● Kaohsiung 886 7 350 2275
 ● Japan 81 568 85 2830 ● Shenzhen 86 755 8418 6263 ● Shanghai 86 21 5424 5141 ● Hong Kong 852 9688 9767
 ● sales@ITG-Electronics.com ● www.ITG-Electronics.com Revision C.2: April 12, 2022

*Due to continuous product improvement, all specifications are subject to change without prior notice. Kindly contact an ITG field application engineer or a sales representative prior to purchase.



4. Inductance vs. Current vs. Temperature Rise Characteristics of SM1608A Series :

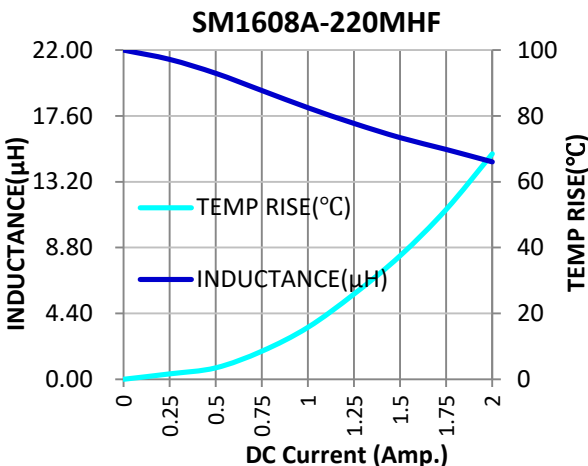
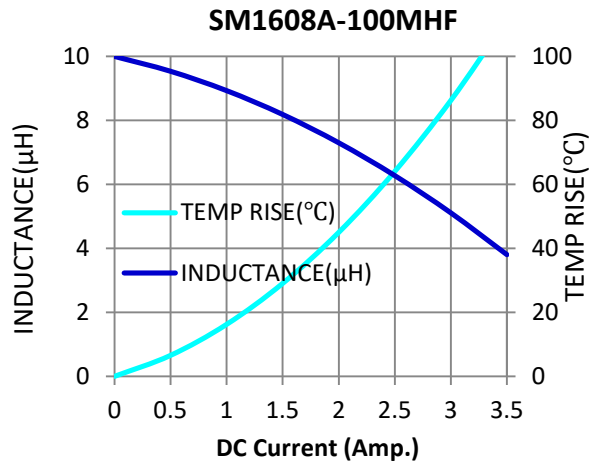
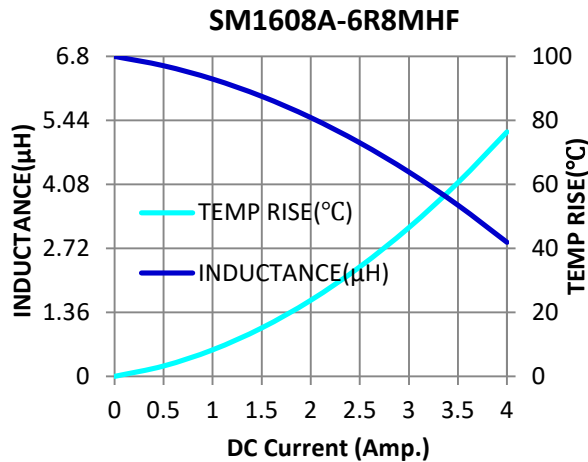
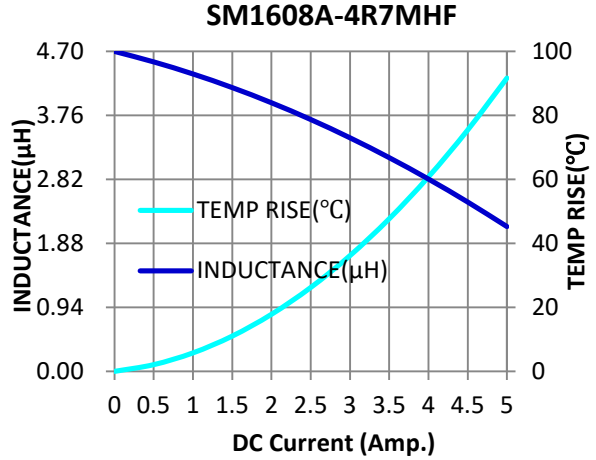
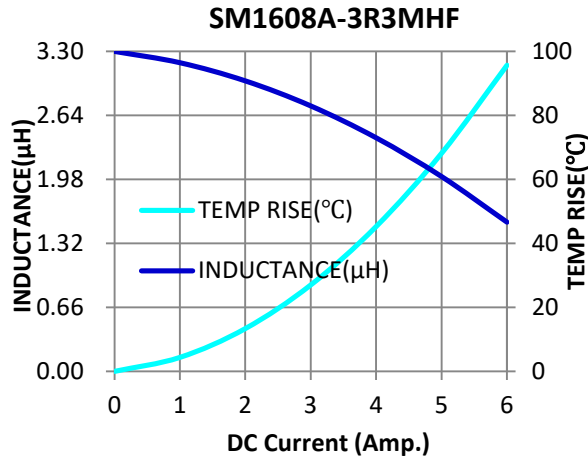

5. PACKAGE SPECIFICATION.(UNIT:mm):

(1).ENCAPSULATION MODE:

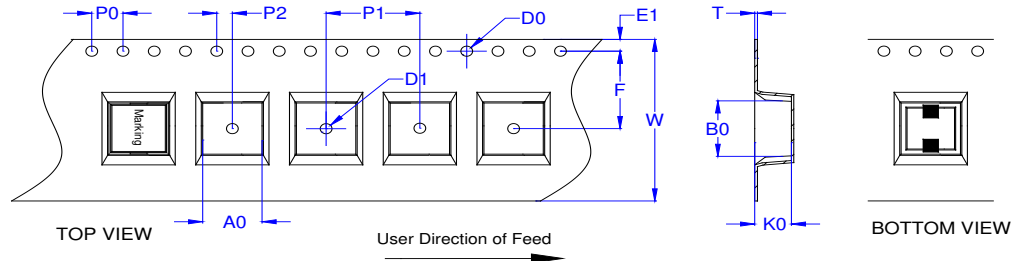

(2).DIMENSION(mm):

W	A0	B0	K0	P1	P0	P2	D0	D1	F	E1	T
12.0±0.30	4.5±0.10	4.8±0.10	2.50±0.15	8.0±0.10	4.0±0.10	2.0±0.10	1.5±0.10	1.5+0.10/-0	5.5±0.10	1.75±0.10	0.35±0.05

(3).REEL SIZE:

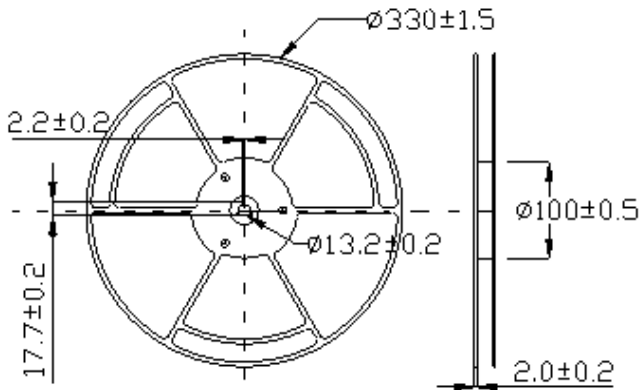

(4).PACKAGE MODE:

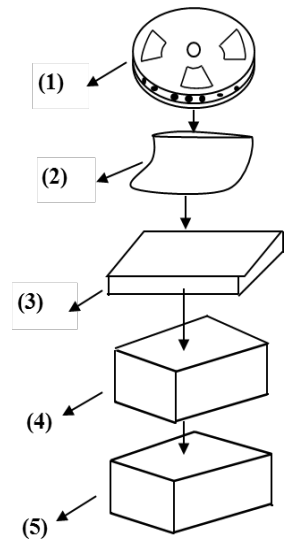

(5).PACKAGING LIST:

No.	Packing Part	Dimension (mm)	Material	Quantity
1	Reel	330	Plastic	3000PCS / Reel
2	Bag	450 X 360 X 0.075	Plastic	1Reel / Bag
3	Small Box	340 X 335 X 45	Paper	2Bag / Small Box
4	Middle Box	356 X 350 X 226	Paper	4Small Boxes / Middle Box
5	Outer Box	378 X 362 X 252	Paper	1Middle Box / Outer Box

(6).WEIGHT: N.W: 0.20g/pcs (APPROX), TOTAL 4.80Kg(APPROX), G.W: TOTAL 8.75Kg(APPROX).

(7).Storage conditions: 20°C~35°C ,75%RH (Max.).

6.RELIABILITY TEST:

6.1 Mechanical Reliability		
Item	Specification and Requirement	Test Method and Remarks
Solderability	The surface of terminal immersed shall be minimum of 95% covered with a new coating of solder	According to J-STD-002 Method D category 3 1. Preheating: 160 ± 10 °C 2.Solder: 99.3%Sn/0.7%Cu , Flux: Rosin 3. Retention time: 255 ± 5 °C for 5 ± 0.5 seconds
Resistance to Soldering Heat	Inductance change: Within ±10% Without mechanical damage such as break	According to MIL-STD-202 Method 210 condition J 1.Solder: 99.3%Sn/0.7%Cu 2.Reflow Peak 235 ± 5°C(30±5s)/Time above 183°C(90~120s)
Vibration	Inductance change: Within ± 10% Without mechanical damage such as break	According to MIL-STD-202 Method 204 5g's for 20 minutes, 12 cycles each of 3 orientations. Note: Use 8"X5" PCB, .031" thick, 7 secure points on one long side and 2 secure points at corners of opposite sides. Parts mounted within 2" from any secure point. Test from 10-2000 Hz.
Shock	Inductance change: Within ±10% Without mechanical damage such as break	According to MIL-STD-202 Method 213 1. Peak value: 100 G 2. Duration of pulse: 11ms 3. 3 times in each positive and negative direction of 3 mutual perpendicular directions.
6.2 Endurance Reliability		
Thermal Shock	Inductance change: Within ± 10% Without distinct damage in appearance	According to IEC68-2-14 Method N(Nb) 1. Repeat 100 cycles as follow: (-55 ± 2 °C; 30 ± 3 min) → (Room temp., 5 min) → (+125 ± 2 °C, 30 ± 3 min) → (Room temp., 1 min) 2. Recovery: 48 + 4 / -0 hours of recovery under the standard condition after the test.
High Temperature & Humidity	Inductance change: Within ± 10% Without distinct damage in appearance	According to MIL-STD-202 Method 103 240 hours 85°C/85%RH. Unpowered. Measurement at 24±4 hours after test conclusion.
Low Temperature Store	Inductance change: Within ± 10% Without distinct damage in appearance	According to IEC68-2-1 Method A(Ad) Store temperature: -55 ± 2 °C, 1000 + 4 / -0 hours
High Temperature Store	Inductance change: Within ± 10% Without distinct damage in appearance	According to MIL-STD-202 Method 108 Store temperature: +125 ± 2 °C, 1000 + 4 / -0 hours



Soldering Reflow Chart

Stage	Precaution	Recommended temperature profile
Reflow soldering	<p>Temperature profile can be referenced after confirming of adhesion , temperature of resistance to soldering heat , component size , soldering etc. sufficient .</p> <p>Note: please refer to the latest IPC/JEDEC J-STD-020: "Moisture/Reflow Sensitivity Classification for Nonhermetic Solid State Surface Mount Devices"</p>	<p>The chart displays a reflow temperature profile with the following key parameters:</p> <ul style="list-style-type: none"> Start Temperature: 25°C Temperature 1: 125°C (Time range: 150s to 210s) Temperature 2: 220°C (Time range: 240s to 480s) Peak Temperature: 260°C (Duration: 10s MAX) End Temperature: 220°C (Time range: 60s to 90s) Cooling Phase: Natural cooling