

Precision 8-Channels, Differential 4-Channels, 36V Analog Multiplexers

Features

- Low On-Capacitance
 - PS508: 30pF
 - PS509: 20pF
- Low Input Leakage: 30pA
- Low Charge Injection: 0.9pC
- Rail-to-Rail Operation
- Wide Supply Range: ±5V to ±18V, 10V to 36V
- Low On-Resistance: 125Ω
- Transition Time: 171ns
- Break-Before-Make Switching Action
- EN Pin Connectable to VDD
- Logic Levels: 2V to VDD
- Low Supply Current: 135µA
- ESD Protection HBM: 2000V
- Totally Lead-Free & Fully RoHS Compliant (Notes 1 & 2)
- Halogen and Antimony Free. “Green” Device (Note 3)
- For automotive applications requiring specific change control (i.e. parts qualified to AEC-Q100/101/200, PPAP capable, and manufactured in IATF 16949 certified facilities), please [contact us](mailto:contact@diodes.com) or your local Diodes representative.
<https://www.diodes.com/quality/product-definitions/>
- Packaging (Pb-free & Green):
 - 16-pin TSSOP (L)
 - 16-pin QSOP (Q)
 - 16-pin SOIC (W)

Truth Tables

PS509			
EN	A1	A0	STATE
0	X*	X*	All channels are off
1	0	0	Channels 1A and 1B on
1	0	1	Channels 2A and 2B on
1	1	0	Channels 3A and 3B on
1	1	1	Channels 4A and 4B on

* X denotes don't care.

Notes:

1. No purposely added lead. Fully EU Directive 2002/95/EC (RoHS), 2011/65/EU (RoHS 2) & 2015/863/EU (RoHS 3) compliant.
2. See <https://www.diodes.com/quality/lead-free/> for more information about Diodes Incorporated’s definitions of Halogen- and Antimony-free, “Green” and Lead-free.
3. Halogen- and Antimony-free “Green” products are defined as those which contain <900ppm bromine, <900ppm chlorine (<1500ppm total Br + Cl) and <1000ppm antimony compounds.

Description

The PS508 and PS509 are modern, complementary metal-oxide semiconductor (CMOS), analog multiplexers (muxes). The PS508 offers 8:1 single-ended channels, whereas the PS509 offers differential 4:1 or dual 4:1 single-ended channels. The PS508 and PS509 work equally well with either dual supplies (±5V to ±18V) or a single supply (10 V to 36 V). They also perform well with symmetric supplies (such as VDD = 12V, VSS = -12V), and un-symmetric supplies (such as VDD = 12V, VSS = -5V). All digital inputs have TTL-logic compatible thresholds, ensuring both TTL and CMOS logic compatibility when operating in the valid supply voltage range.

The PS508 and PS509 have very low on and off leakage currents, allowing these multiplexers to switch signals from high input impedance sources with minimal error. A low supply current of 135 µA allows for use in portable applications.

Applications

- Factory Automation and Industrial Process Controls
- Programmable Logic Controllers (PLC)
- Analog Input Modules
- ATE Test Equipment
- Digital Multimeters
- Battery Monitoring Systems

Truth Tables

PS508				
EN	A2	A1	A0	STATE
0	X*	X*	X*	All channels are off
1	0	0	0	Channel 1 on
1	0	0	1	Channel 2 on
1	0	1	0	Channel 3 on
1	0	1	1	Channel 4 on
1	1	0	0	Channel 5 on
1	1	0	1	Channel 6 on
1	1	1	0	Channel 7 on
1	1	1	1	Channel 8 on

* X denotes don't care.

Pin Configuration PS508

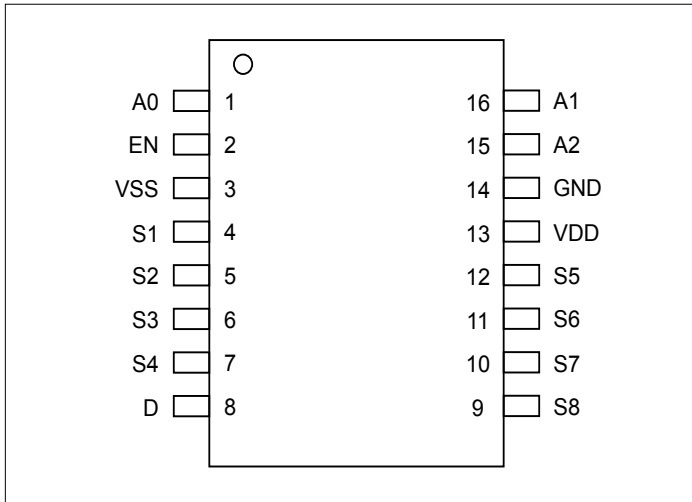

Pin Description

Pin#	Pin Name	Type	Description
1	A0	I	Address line 0.
16	A1	I	Address line 1.
15	A2	I	Address line 2.
8	D	I/O	Drain pin.
2	EN	I	Active high digital input. When this pin is low, all switches are turned off. When this pin is high, the A[2:0] logic inputs determine which switch is turned on.
14	GND	Power	Ground.
4	S1	I/O	Source pin 1.
5	S2	I/O	Source pin 2.
6	S3	I/O	Source pin 3.
7	S4	I/O	Source pin 4.
12	S5	I/O	Source pin 5.
11	S6	I/O	Source pin 6.
10	S7	I/O	Source pin 7.
9	S8	I/O	Source pin 8.
13	VDD	Power	Positive power supply. This pin is the most positive power-supply potential. For reliable operation, connect a decoupling capacitor ranging from 0.1 μ F to 10 μ F between VDD and GND.
3	VSS	Power	Negative power supply. This pin is the most negative power-supply potential. In single-supply applications, this pin can be connected to ground. For reliable operation, connect a decoupling capacitor ranging from 0.1 μ F to 10 μ F between VSS and GND.

Note: I = Input, O = Output and I/O = Input/Output

Pin Configuration PS509

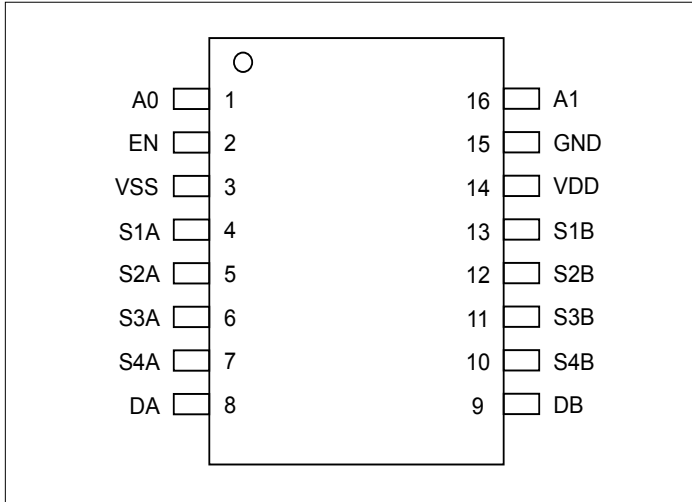

Pin Description

Pin#	Pin Name	Type	Description
1	A0	I	Address line 0.
16	A1	I	Address line 1.
8	DA	I/O	Drain pin A. Can be an input or output.
9	DB	I/O	Drain pin B. Can be an input or output.
2	EN	I	Active high digital input. When this pin is low, all switches are turned off. When this pin is high, the A[1:0] logic inputs determine which pair of switches is turned on.
15	GND	Pwr	Ground (0 V) reference
4	S1A	I/O	Source pin 1A. Can be an input or output.
5	S2A	I/O	Source pin 2A. Can be an input or output.
6	S3A	I/O	Source pin 3A. Can be an input or output.
7	S4A	I/O	Source pin 4A. Can be an input or output.
13	S1B	I/O	Source pin 1B. Can be an input or output.
12	S2B	I/O	Source pin 2B. Can be an input or output.
11	S3B	I/O	Source pin 3B. Can be an input or output.
10	S4B	I/O	Source pin 4B. Can be an input or output.
14	VDD	Pwr	Positive power supply. This pin is the most positive power supply potential. For reliable operation, connect a decoupling capacitor ranging from 0.1 μF to 10 μF between VDD and GND.
3	VSS	Pwr	Negative power supply. This pin is the most negative power supply potential. In single supply applications, this pin can be connected to ground. For reliable operation, connect a decoupling capacitor ranging from 0.1 μF to 10 μF between VSS and GND.

Note: I = Input, O = Output and I/O = Input/Output

Maximum Ratings

(Above which useful life may be impaired. For user guidelines, not tested.)

Storage Temperature.....	-65°C to +150°C
Junction Temperature	150°C
Operating Temperature	-40°C to +125°C
Supply Voltage to Ground Potential, V _{DD}	-0.3V to +40V
Supply Voltage to Ground Potential, V _{SS}	-40 to +0.3V
Supply Voltage, V _{DD} -V _{SS}	+40V
Digital Input Voltage (EN A0, A1, A2 pins).....	V _{SS} -0.3 to V _{DD} +0.3V
Digital Input Current (EN A0, A1, A2 pins).....	-30 to +30 mA
Analog Input Voltage (Sx, SxA, SxB pins).....	V _{SS} -2 to V _{DD} +2V
Analog Input Current (Sx, SxA, SxB pins).....	-30 to +30 mA
Analog Output Voltage (D, DA, DB pins).....	V _{SS} -2 to V _{DD} +2V
Analog Output Current (D, DA, DB pins).....	-30 to +30 mA

Note:

Stresses greater than those listed under MAXIMUM RATINGS may cause permanent damage to the device. This is a stress rating only and functional operation of the device at these or any other conditions above those indicated in the operational sections of this specification is not implied. Exposure to absolute maximum rating conditions for extended periods may affect reliability.

ESD Ratings

Symbol	Parameters	Conditions	Value	Units
V _(ESD)	Electrostatic discharge	Human-body model (HBM), per ANSI/ESDA/JEDEC JS-001 ⁽¹⁾	2000	V
		Charged-device model (CDM), per JEDEC specification JESD22-C101 ⁽²⁾	500	V

Note:

1. JEDEC document JEP155 states that 500-V HBM allow safe manufacturing with a standard ESD control process.
2. JEDEC document JEP157 states that 250-V HBM allow safe manufacturing with a standard ESD control process.

Recommended Operating Conditions

Symbol	Parameters	Min.	Typ.	Max.	Units
V _{DD} ⁽¹⁾	Positive power-supply voltage	Dual supply	5	18	V
		Single supply	10	36	
V _{SS} ⁽²⁾	Negative power-supply voltage (dual supply)	-5		-18	V
V _{DD} - V _{SS}	Supply voltage	10		36	V
VS	Source pins voltage ⁽³⁾	V _{SS}		V _{DD}	V
VD	Drain pins voltage	V _{SS}		V _{DD}	V
V _{EN}	Enable pin voltage	V _{SS}		V _{DD}	V
VA	Address pins voltage	V _{SS}		V _{DD}	V
I _{CH}	Channel current (TA = 25°C)	-25		25	mA
TA	Operating temperature	-40		125	°C

Note:

1. When V_{SS} = 0 V, V_{DD} can range from 10 V to 36 V.
2. V_{DD} and V_{SS} can be any value as long as 10 V ≤ (V_{DD} - V_{SS}) ≤ 36 V, and V_{DD} ≥ 5 V.
3. VS is the voltage on all the S pins.

Electrical Characteristics: Dual Supply

At $T_A = 25^\circ\text{C}$, $V_{DD} = 15\text{V}$, and $V_{SS} = -15\text{V}$ (unless otherwise noted)

Symbol	Parameters	Conditions	Min.	Typ.	Max.	Units	
Analog Switch							
	Analog signal range	$T_A = -40^\circ\text{C}$ to $+125^\circ\text{C}$	V_{SS}		V_{DD}	V	
R_{ON}	On-resistance	$V_S = 0\text{V}$, $I_{CH} = 1\text{mA}$		125	170	Ω	
				145	200	Ω	
		$V_S = \pm 10\text{V}$, $I_{CH} = 1\text{mA}$	$T_A = -40^\circ\text{C}$ to $+85^\circ\text{C}$			230	Ω
			$T_A = -40^\circ\text{C}$ to $+125^\circ\text{C}$			250	Ω
ΔR_{ON}	On-resistance mismatch between channels	$V_S = \pm 10\text{V}$, $I_{CH} = 1\text{mA}$		2.4	6	Ω	
			$T_A = -40^\circ\text{C}$ to $+85^\circ\text{C}$			9	Ω
			$T_A = -40^\circ\text{C}$ to $+125^\circ\text{C}$			11	Ω
R_{FLAT}	On-resistance flatness	$V_S = 10\text{V}, 0\text{V}, -10\text{V}$		22	45	Ω	
			$T_A = -40^\circ\text{C}$ to $+85^\circ\text{C}$			53	Ω
			$T_A = -40^\circ\text{C}$ to $+125^\circ\text{C}$			58	Ω
	On-resistance drift	$V_S = 0\text{V}$		0.52		$\%/^\circ\text{C}$	
$I_{S(OFF)}$	Input leakage current	Switch state is off, $V_S = \pm 10\text{V}$, $V_D = \pm 10\text{V}^{(1)}$		-1	0.03	1	nA
			$T_A = -40^\circ\text{C}$ to $+85^\circ\text{C}$	-10		10	nA
			$T_A = -40^\circ\text{C}$ to $+125^\circ\text{C}$	-25		25	nA
$I_{D(OFF)}$	Output off leakage current	Switch state is off, $V_S = \pm 10\text{V}$, $V_D = \pm 10\text{V}^{(1)}$		-1	0.22	1	nA
			$T_A = -40^\circ\text{C}$ to $+85^\circ\text{C}$	-10		10	nA
			$T_A = -40^\circ\text{C}$ to $+125^\circ\text{C}$	-50		50	nA
$I_{D(ON)}$	Output on leakage current	Switch state is on, $V_D = \pm 10\text{V}$, $V_S = \text{floating}$		-1	0.25	1	nA
			$T_A = -40^\circ\text{C}$ to $+85^\circ\text{C}$	-10		10	nA
			$T_A = -40^\circ\text{C}$ to $+125^\circ\text{C}$	-50		50	nA
Logic Input							
V_{IH}	High-level input voltage		2.0			V	
V_{IL}	Low-level input voltage				0.8	V	
ID	Input current				0.15	μA	
Switch Dynamics ⁽²⁾							
t_{ON}	Enable turn-on time	$V_S = \pm 10\text{V}$, $R_L = 300\Omega$, $C_L = 35\text{pF}$			126	210	ns
			$T_A = -40^\circ\text{C}$ to $+85^\circ\text{C}$			210	ns
			$T_A = -40^\circ\text{C}$ to $+125^\circ\text{C}$			210	ns
t_{OFF}	Enable turn-off time	$V_S = \pm 10\text{V}$, $R_L = 300\Omega$, $C_L = 35\text{pF}$			125	191	ns
			$T_A = -40^\circ\text{C}$ to $+85^\circ\text{C}$			191	ns
			$T_A = -40^\circ\text{C}$ to $+125^\circ\text{C}$			191	ns

Electrical Characteristics: Dual Supply Cont.

Symbol	Parameters	Conditions	Min.	Typ.	Max.	Units	
t_t	Transition time	$V_S = 10V, R_L = 300\Omega,$ $C_L = 35pF,$		171	310	ns	
			$T_A = -40^\circ C \text{ to } +85^\circ C$			310	ns
			$T_A = -40^\circ C \text{ to } +125^\circ C$			310	ns
t_{BBM}	Break-before-make time delay	$V_S = 10V, R_L = 300\Omega, C_L = 35pF, T_A = -40^\circ C \text{ to } +125^\circ C$	30	75		ns	
Q_j	Charge injection	$C_L = 1nF, R_S = 0\Omega$	$V_S = 0V$	0.9		pC	
			$V_S = -15V \text{ to } +15V$	± 2		pC	
	Off-isolation	$R_L = 50\Omega, V_S = 1V_{RMS},$ $f = 1MHz$	Nonadjacent channel to D, DA, DB	-96		dB	
			Adjacent channel to D, DA, DB	-85		dB	
	Channel-to-channel crosstalk	$R_L = 50\Omega, V_S = 1V_{RMS},$ $f = 1MHz$	Nonadjacent channels	-96		dB	
			Adjacent channels	-88		dB	
$C_{S(OFF)}$	Input off-capacitance	$f = 1MHz, V_S = 0V$		5	7	pF	
$C_{D(OFF)}$	Output off-capacitance	$f = 1MHz, V_S = 0V$	PS508	24	30	pF	
			PS509	15	20	pF	
$C_{D(ON)}$	Input/Output on-capacitance	$f = 1MHz, V_S = 0V$	PS508	30	36	pF	
			PS509	20	25	pF	
Power Supply							
	V_{DD} supply current	All $V_A = 0V \text{ or } 3.3V,$ $V_S = 0V, V_{EN} = 3.3V$		135	200	μA	
			$T_A = -40^\circ C \text{ to } +85^\circ C$			200	μA
			$T_A = -40^\circ C \text{ to } +125^\circ C$			200	μA
	V_{SS} supply current	All $V_A = 0V \text{ or } 3.3V,$ $V_S = 0V, V_{EN} = 3.3V,$		135	200	μA	
			$T_A = -40^\circ C \text{ to } +85^\circ C$			200	μA
			$T_A = -40^\circ C \text{ to } +125^\circ C$			200	μA

Note:

- When VS is positive, VD is negative, and vice versa.
- Specified by design, not production tested.

Electrical Characteristics: Single Supply

at $T_A = 25^\circ\text{C}$, $V_{DD} = 12\text{V}$, and $V_{SS} = 0\text{V}$ (unless otherwise noted)

Symbol	Parameters	Conditions	Min.	Typ.	Max.	Units	
Analog Switch							
	Analog signal range	$T_A = -40^\circ\text{C}$ to $+125^\circ\text{C}$	V_{SS}		V_{DD}	V	
R_{ON}	On-resistance	$V_S = +10\text{V}$, $I_{CH} = 1\text{mA}$		235	340	Ω	
			$T_A = -40^\circ\text{C}$ to $+85^\circ\text{C}$		390	Ω	
			$T_A = -40^\circ\text{C}$ to $+125^\circ\text{C}$		430	Ω	
ΔR_{ON}	On-resistance mismatch between channels	$V_S = +10\text{V}$, $I_{CH} = 1\text{mA}$		3.1	12	Ω	
			$T_A = -40^\circ\text{C}$ to $+85^\circ\text{C}$		19	Ω	
			$T_A = -40^\circ\text{C}$ to $+125^\circ\text{C}$		23	Ω	
	On-resistance drift	$V_S = 10\text{V}$		0.47		$\%/^\circ\text{C}$	
$I_{S(OFF)}$	Input leakage current	Switch state is off, $V_S = 1\text{V}$ and $V_D = 10\text{V}$, or $V_S = 10\text{V}$ and $V_D = 1\text{V}^{(1)}$		-1	0.03	1	nA
			$T_A = -40^\circ\text{C}$ to $+85^\circ\text{C}$	-10		10	nA
			$T_A = -40^\circ\text{C}$ to $+125^\circ\text{C}$	-25		25	nA
$I_{D(OFF)}$	Output off leakage current	Switch state is off, $V_S = 1\text{V}$ and $V_D = 10\text{V}$, or $V_S = 10\text{V}$ and $V_D = 1\text{V}^{(1)}$		-1	0.22	1	nA
			$T_A = -40^\circ\text{C}$ to $+85^\circ\text{C}$	-10		10	nA
			$T_A = -40^\circ\text{C}$ to $+125^\circ\text{C}$	-50		50	nA
$I_{D(ON)}$	Output on leakage current	Switch state is on, $V_D = 1\text{V}$ and 10V , $V_S = \text{floating}$		-1	0.25	1	nA
			$T_A = -40^\circ\text{C}$ to $+85^\circ\text{C}$	-10		10	nA
			$T_A = -40^\circ\text{C}$ to $+125^\circ\text{C}$	-50		50	nA
Logic Input							
V_{IH}	High-level input voltage		2.0			V	
V_{IL}	Low-level input voltage				0.8	V	
ID	Input current				0.15	μA	
Switch Dynamics ⁽²⁾							
t_{ON}	Enable turn-on time	$V_S = 8\text{V}$, $R_L = 300\Omega$, $C_L = 35\text{pF}$			115	220	ns
			$T_A = -40^\circ\text{C}$ to $+85^\circ\text{C}$			220	ns
			$T_A = -40^\circ\text{C}$ to $+125^\circ\text{C}$			220	ns
t_{OFF}	Enable turn-off time	$V_S = 8\text{V}$, $R_L = 300\Omega$, $C_L = 35\text{pF}$			118	200	ns
			$T_A = -40^\circ\text{C}$ to $+85^\circ\text{C}$			200	ns
			$T_A = -40^\circ\text{C}$ to $+125^\circ\text{C}$			200	ns

Electrical Characteristics: Single Supply Cont.

Symbol	Parameters	Conditions	Min.	Typ.	Max.	Units
t_t	Transition time	$V_S = 8V, R_L = 300\Omega, C_L = 35pF$		212	418	ns
		$V_S = 8V, R_L = 300\Omega, C_L = 35pF$	$T_A = -40^\circ C \text{ to } +85^\circ C$		418	ns
		$V_S = 8V, R_L = 300\Omega, C_L = 35pF$	$T_A = -40^\circ C \text{ to } +125^\circ C$		418	ns
t_{BBM}	Break-before-make time delay	$V_S = 8V, R_L = 300\Omega, C_L = 35pF, T_A = -40^\circ C \text{ to } +125^\circ C$	30	120		ns
Q_j	Charge injection	$C_L = 1nF, R_S = 0\Omega$	$V_S = 6V$	0.5		pC
			$V_S = 0V \text{ to } 12V,$	± 1.5		pC
	Off-isolation	$R_L = 50\Omega, V_S = 1V_{RMS}, f = 1MHz$	Nonadjacent channel to D, DA, DB	-96		dB
			Adjacent channel to D, DA, DB	-85		dB
	Channel-to-channel crosstalk	$R_L = 50\Omega, V_S = 1V_{RMS}, f = 1MHz$	Nonadjacent channels	-96		dB
			Adjacent channels	-88		dB
$C_{S(OFF)}$	Input off-capacitance	$f = 1MHz, V_S = 6V$		5	7	pF
$C_{D(OFF)}$	Output off-capacitance	$f = 1MHz, V_S = 6V$	PS508	24	30	pF
			PS509	15	20	pF
$C_{D(ON)}$	Input/Output on-capacitance	$f = 1MHz, V_S = 6V$	PS508	30	36	pF
			PS509	21	25	pF
Power Supply						
	VDD supply current	All $V_A = 0V \text{ or } 3.3V, V_S = 0V, V_{EN} = 3.3V$		104	160	μA
			$T_A = -40^\circ C \text{ to } +85^\circ C$		160	μA
			$T_A = -40^\circ C \text{ to } +125^\circ C$		160	μA
	VSS supply current	All $V_A = 0V \text{ or } 3.3V, V_S = 0V, V_{EN} = 3.3V$		104	160	μA
			$T_A = -40^\circ C \text{ to } +85^\circ C$		160	μA
			$T_A = -40^\circ C \text{ to } +125^\circ C$		160	μA

Note:

1. When V_S is 1 V, V_D is 10 V, and vice versa.
2. Specified by design, not production tested.

Test Circuit

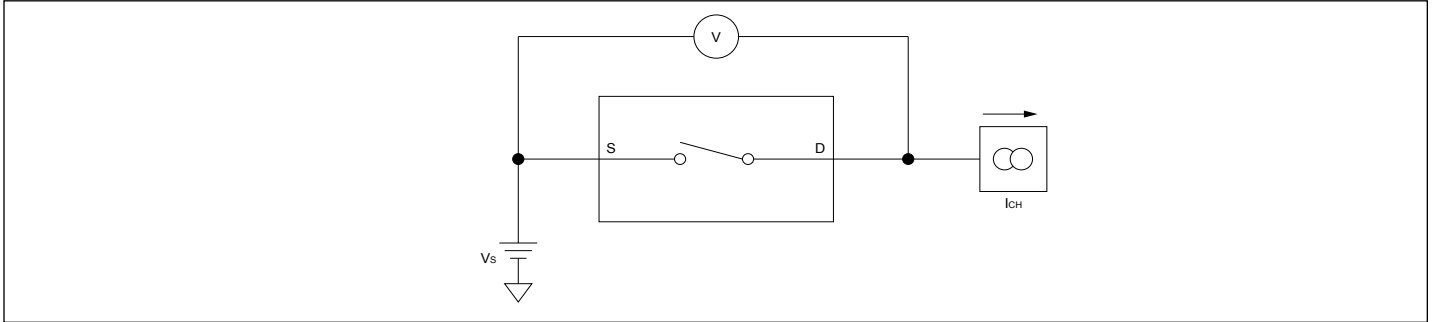

Figure 1. On-Resistance Measurement Setup

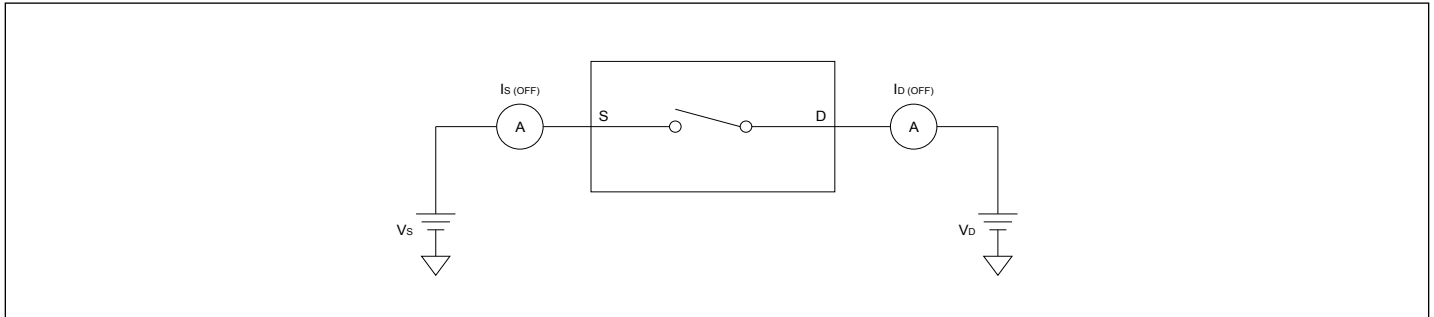

Figure 2. Off-Leakage Measurement Setup

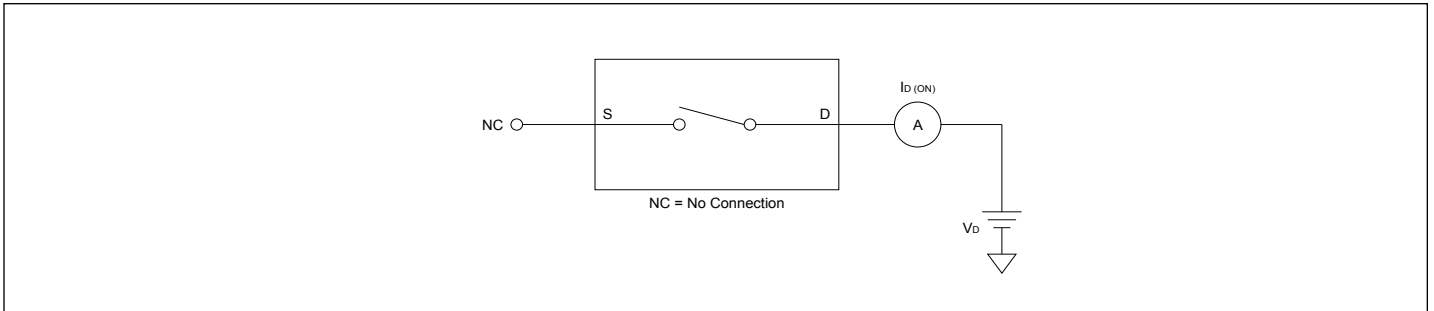

Figure 3. On-Leakage Measurement Setup

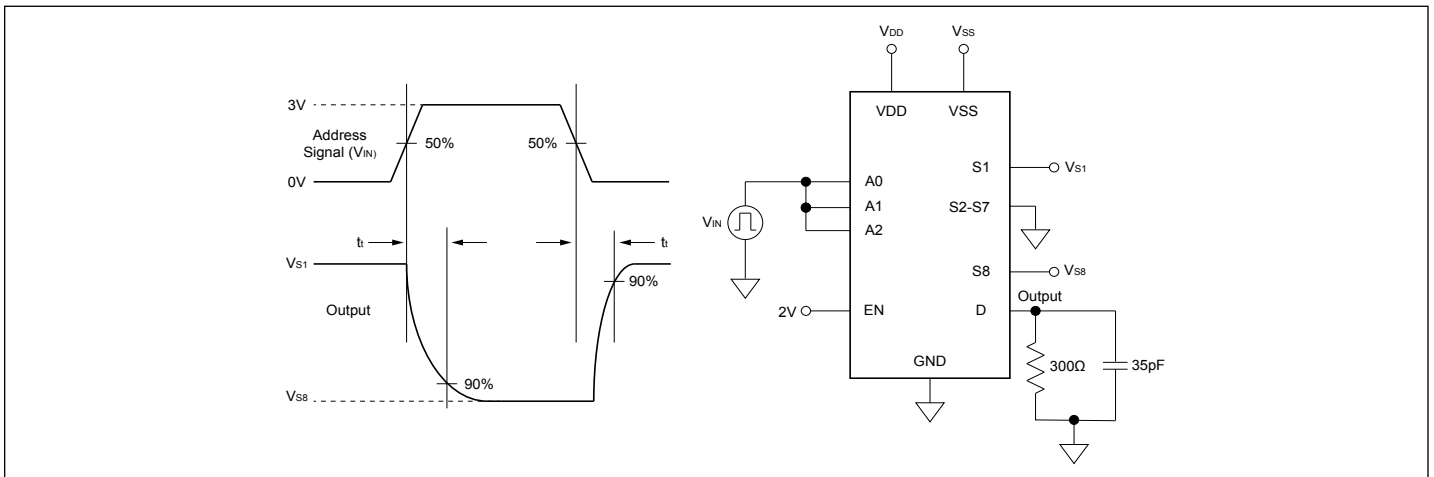

Figure 4. Transition-Time Measurement Setup

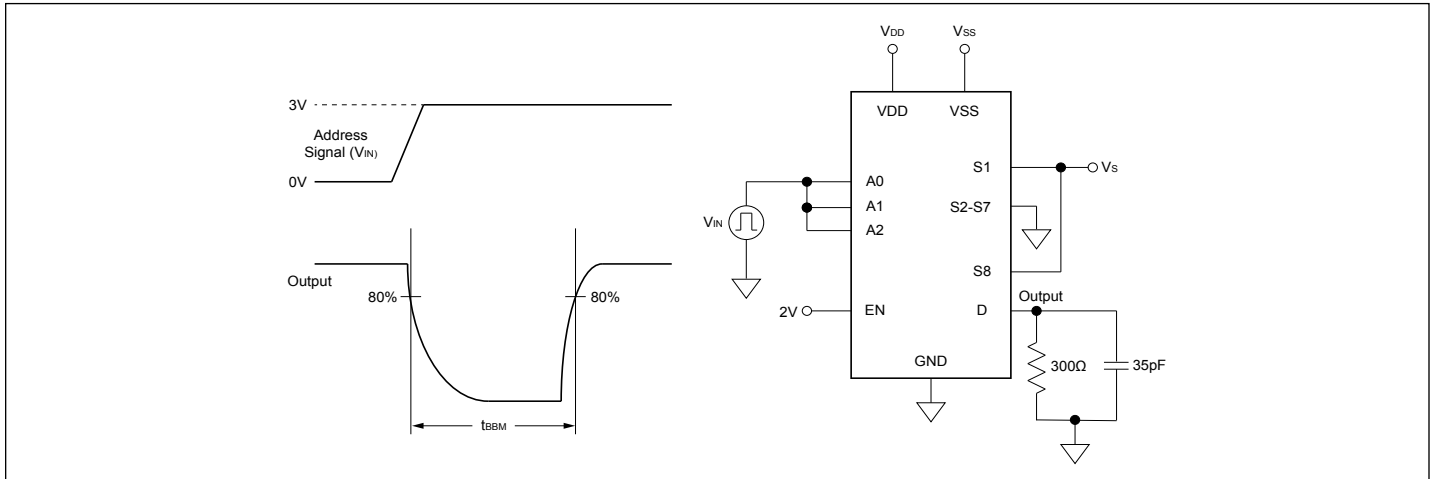

Figure 5. Break-Before-Make Delay Measurement Setup

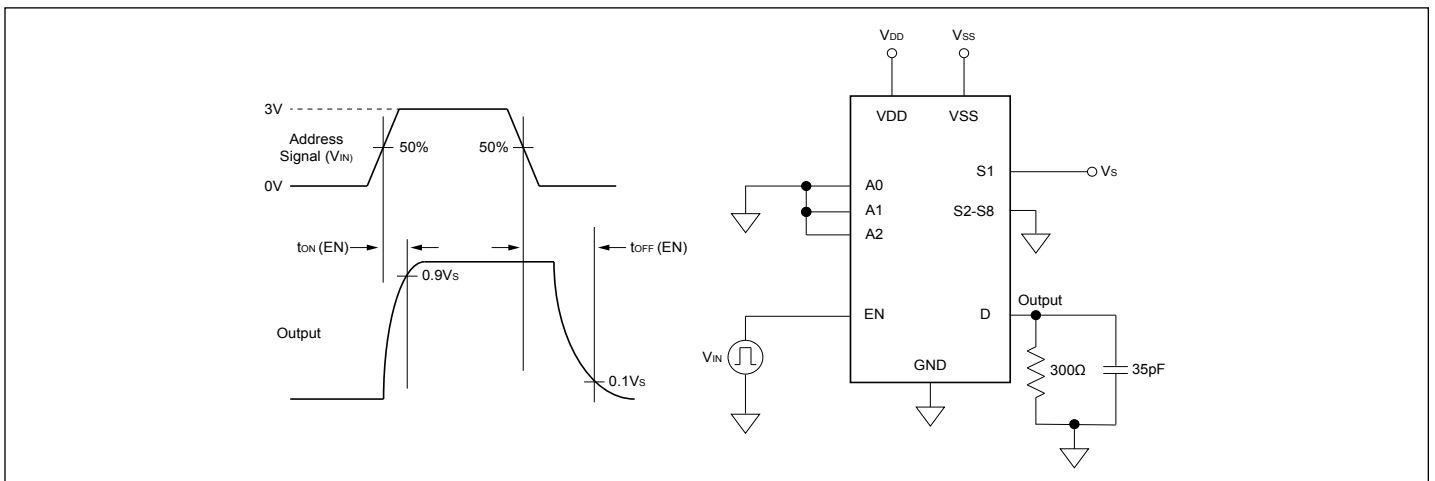

Figure 6. Turn-On and Turn-Off Time Measurement Setup

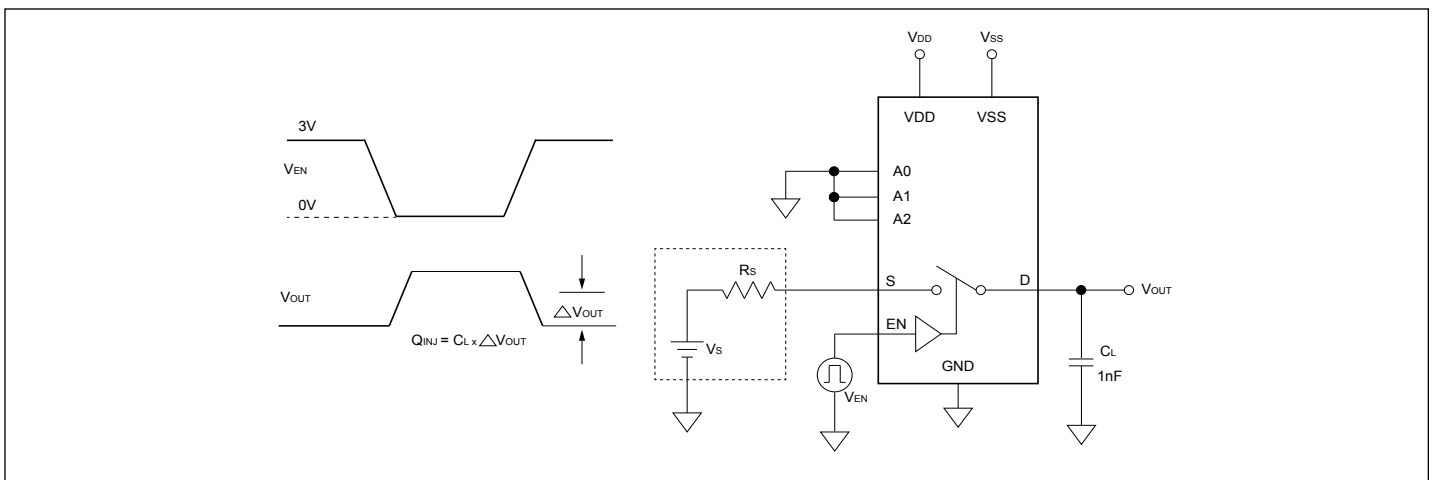

Figure 7. Charge-Injection Measurement Setup

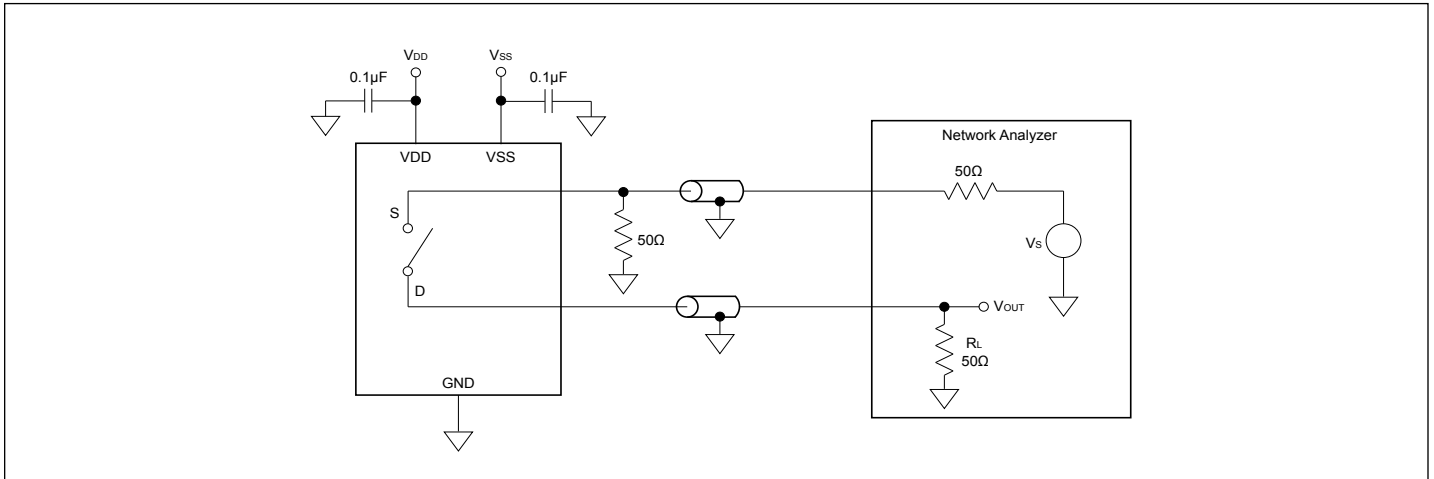

Figure 8. Off Isolation Measurement Setup

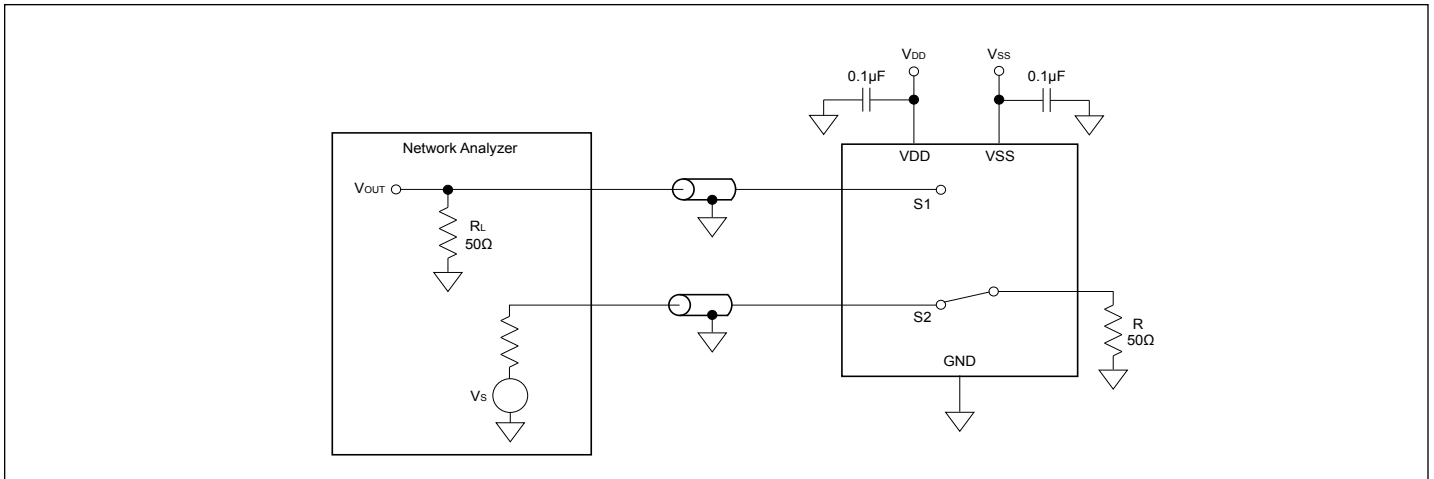
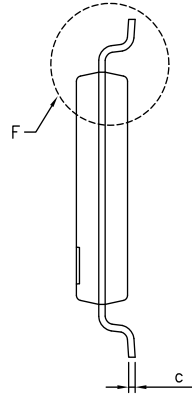
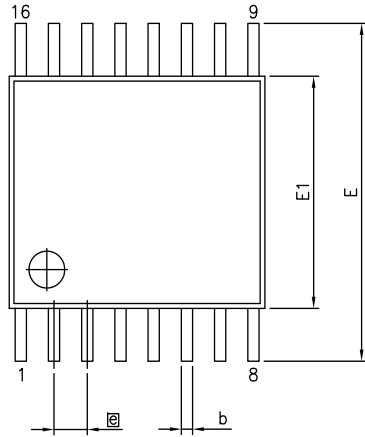

Figure 9. Channel-to-Channel Crosstalk Measurement Setup

Part Marking

Top mark not available at this time. To obtain advance information regarding the top mark, please contact your local sales representative.

Packaging Mechanical: 16-TSSOP (L)



SYMBOLS	MIN.	NOM.	MAX.
A	–	–	1.20
A1	0.05	–	0.15
A2	0.80	1.00	1.05
b	0.19	–	0.30
c	0.09	–	0.20
D	4.90	5.00	5.10
E1	4.30	4.40	4.50
E	6.20	6.40	6.60
e	0.65 BSC		
L1	1.00 REF		
L	0.45	0.60	0.75
S	0.20	–	–
θ	0°	–	8°

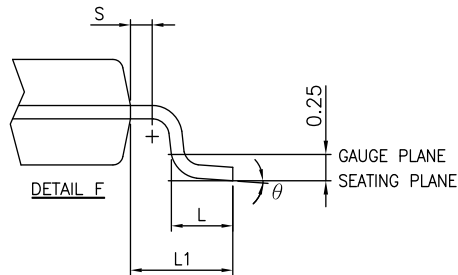
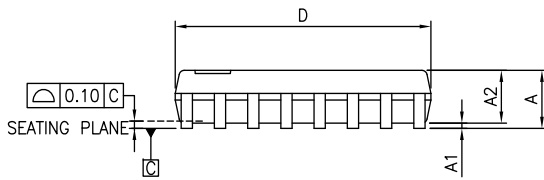

NOTES:

1. ALL DIMENSIONS IN MILLIMETERS. ANGLES IN DEGREES.
2. JEDEC MO-153F
3. DIMENSIONS DOES NOT INCLUDE MOLD FLASH, PROTRUSIONS OR GATE BURRS.

16-0061

		DATE: 03/24/16
DESCRIPTION: 16-Pin, 173mil Wide TSSOP		
PACKAGE CODE: L (L16)		
DOCUMENT CONTROL #: PD-1310		REVISION: G

Packaging Mechanical: 16-QSOP (Q)

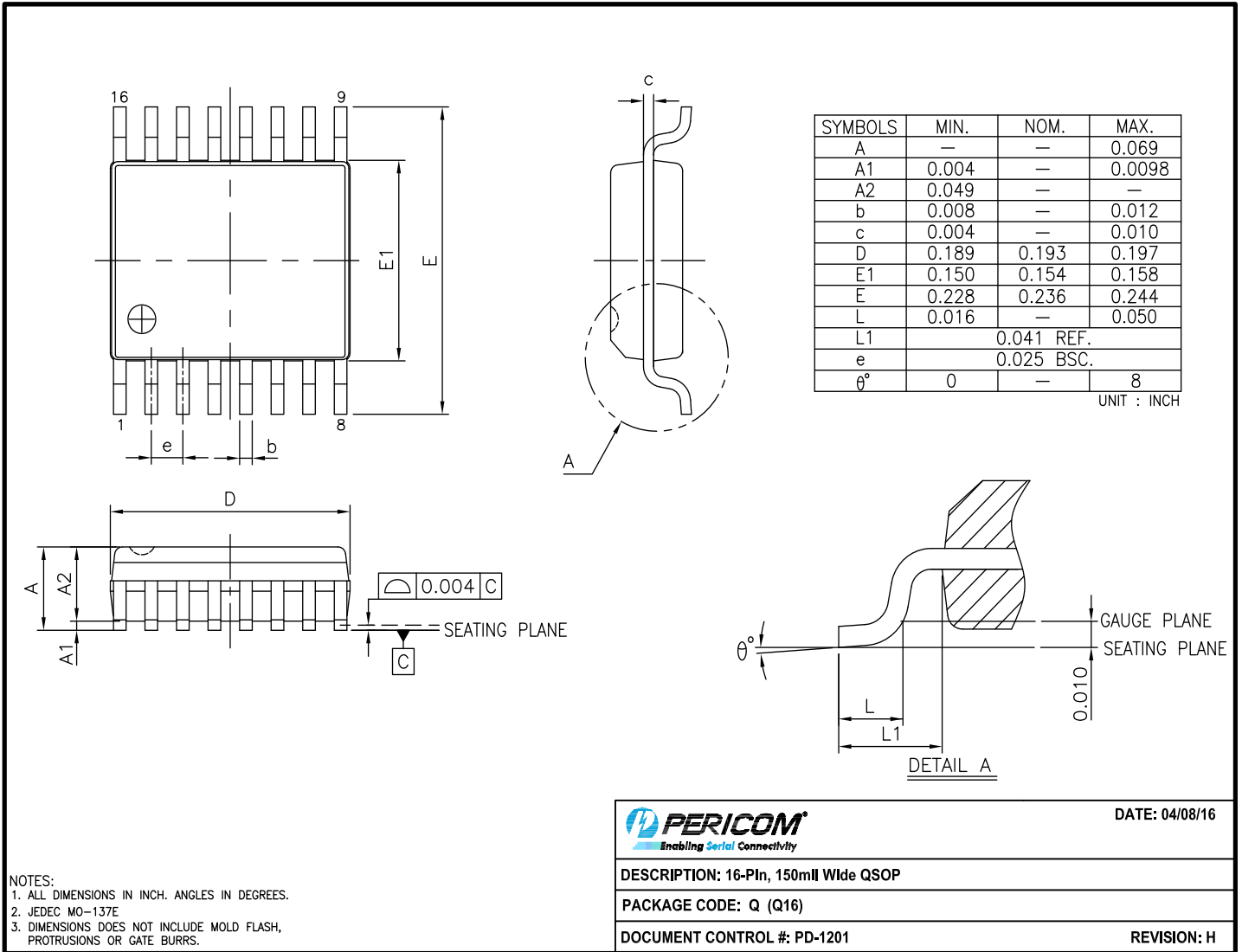

16-0056

Packaging Mechanical: 16-SOIC (W)

SYMBOLS	MIN.	NOM.	MAX.
A	—	—	1.75
A1	0.10	—	0.25
A2	1.00	—	—
b	0.31	—	0.51
c	0.10	—	0.25
D	9.80	9.90	10.0
E	5.80	6.00	6.20
E1	3.80	3.90	4.00
e	1.27 BSC		
L	0.40	—	1.27
h	0.15	—	0.50
θ°	0	—	8

NOTES:
 1. ALL DIMENSIONS IN MILLIMETERS. ANGLES IN DEGREES.
 2. JEDEC OUTLINE : MS-012 AC
 3. DIMENSIONS DOES NOT INCLUDE MOLD FLASH, PROTRUSIONS OR GATE BURRS.
 4. THE MIN. DIMENSION OF A2 AND h ARE OUT OF JEDEC SPEC.

16-0145

		DATE: 06/30/16
DESCRIPTION: 16-Pin, 150mil Wide SOIC		
PACKAGE CODE: W		
DOCUMENT CONTROL #: PD-1004		REVISION: G

For latest package info.

please check: <http://www.diodes.com/design/support/packaging/pericom-packaging/packaging-mechanicals-and-thermal-characteristics/>

Ordering Information

Ordering Code	Package Code	Package Description
PS508LEX	L	16-pin, 173mil Wide (TSSOP)
PS508QEX	Q	16-pin, 150mil Wide (QSOP)
PS508WEX	W	16-pin, 150mil Wide (SOIC)
PS509LEX	L	16-pin, 173mil Wide (TSSOP)
PS509QEX	Q	16-pin, 150mil Wide (QSOP)
PS509WEX	W	16-pin, 150mil Wide (SOIC)

Notes:

1. No purposely added lead. Fully EU Directive 2002/95/EC (RoHS), 2011/65/EU (RoHS 2) & 2015/863/EU (RoHS 3) compliant.
2. See <https://www.diodes.com/quality/lead-free/> for more information about Diodes Incorporated's definitions of Halogen- and Antimony-free, "Green" and Lead-free.
3. Halogen- and Antimony-free "Green" products are defined as those which contain <900ppm bromine, <900ppm chlorine (<1500ppm total Br + Cl) and <1000ppm antimony compounds.
4. E = Pb-free and Green
5. X suffix = Tape/Reel

IMPORTANT NOTICE

DIODES INCORPORATED MAKES NO WARRANTY OF ANY KIND, EXPRESS OR IMPLIED, WITH REGARDS TO THIS DOCUMENT, INCLUDING, BUT NOT LIMITED TO, THE IMPLIED WARRANTIES OF MERCHANTABILITY AND FITNESS FOR A PARTICULAR PURPOSE (AND THEIR EQUIVALENTS UNDER THE LAWS OF ANY JURISDICTION).

Diodes Incorporated and its subsidiaries reserve the right to make modifications, enhancements, improvements, corrections or other changes without further notice to this document and any product described herein. Diodes Incorporated does not assume any liability arising out of the application or use of this document or any product described herein; neither does Diodes Incorporated convey any license under its patent or trademark rights, nor the rights of others. Any Customer or user of this document or products described herein in such applications shall assume all risks of such use and will agree to hold Diodes Incorporated and all the companies whose products are represented on Diodes Incorporated website, harmless against all damages.

Diodes Incorporated does not warrant or accept any liability whatsoever in respect of any products purchased through unauthorized sales channel.

Should Customers purchase or use Diodes Incorporated products for any unintended or unauthorized application, Customers shall indemnify and hold Diodes Incorporated and its representatives harmless against all claims, damages, expenses, and attorney fees arising out of, directly or indirectly, any claim of personal injury or death associated with such unintended or unauthorized application.

Products described herein may be covered by one or more United States, international or foreign patents pending. Product names and markings noted herein may also be covered by one or more United States, international or foreign trademarks.

This document is written in English but may be translated into multiple languages for reference. Only the English version of this document is the final and definitive format released by Diodes Incorporated.

LIFE SUPPORT

Diodes Incorporated products are specifically not authorized for use as critical components in life support devices or systems without the express written approval of the Chief Executive Officer of Diodes Incorporated. As used herein:

A. Life support devices or systems are devices or systems which:

1. are intended to implant into the body, or

2. support or sustain life and whose failure to perform when properly used in accordance with instructions for use provided in the labeling can be reasonably expected to result in significant injury to the user.

B. A critical component is any component in a life support device or system whose failure to perform can be reasonably expected to cause the failure of the life support device or to affect its safety or effectiveness.

Customers represent that they have all necessary expertise in the safety and regulatory ramifications of their life support devices or systems, and acknowledge and agree that they are solely responsible for all legal, regulatory and safety-related requirements concerning their products and any use of Diodes Incorporated products in such safety-critical, life support devices or systems, notwithstanding any devices- or systems-related information or support that may be provided by Diodes Incorporated. Further, Customers must fully indemnify Diodes Incorporated and its representatives against any damages arising out of the use of Diodes Incorporated products in such safety-critical, life support devices or systems.

Copyright © 2020, Diodes Incorporated

www.diodes.com