

## Features

- **SuperWIDE HIGH DENSITY IN-SYSTEM PROGRAMMABLE LOGIC**
  - 3.3V Power Supply
  - User Selectable 3.3V/2.5V I/O
  - 12000 PLD Gates / 256 Macrocells
  - Up to 192 I/O Pins
  - 256 Registers
  - High-Speed Global Interconnect
  - SuperWIDE 32 Generic Logic Block (GLB) Size for Optimum Performance
  - SuperWIDE Input Gating (68 Inputs) for Fast Counters, State Machines, Address Decoders, etc.
  - PCB Efficient Ball Grid Array (BGA) Package Options
  - Interfaces with Standard 5V TTL Devices
- **HIGH PERFORMANCE E<sup>2</sup>CMOS<sup>®</sup> TECHNOLOGY**
  - $f_{max} = 125$  MHz Maximum Operating Frequency
  - $t_{pd} = 7.5$  ns Propagation Delay
  - Enhanced  $t_{su2} = 7$  ns,  $t_{su3} (CLK0/1) = 4.5$  ns,  $t_{su3} (CLK2/3) = 3.5$  ns
  - TTL/3.3V/2.5V Compatible Input Thresholds and Output Levels
  - Electrically Erasable and Reprogrammable
  - Non-Volatile
  - Programmable Speed/Power Logic Path Optimization
- **IN-SYSTEM PROGRAMMABLE**
  - Increased Manufacturing Yields, Reduced Time-to-Market, and Improved Product Quality
  - Reprogram Soldered Devices for Faster Debugging
- **100% IEEE 1149.1 BOUNDARY SCAN TESTABLE AND 3.3V IN-SYSTEM PROGRAMMABLE**
- **ARCHITECTURE FEATURES**
  - Enhanced Pin-Locking Architecture with Single-Level Global Routing Pool and SuperWIDE GLBs
  - Wrap Around Product Term Sharing Array Supports up to 35 Product Terms Per Macrocell
  - Macrocells Support Concurrent Combinatorial and Registered Functions
  - Macrocell Registers Feature Multiple Control Options Including Set, Reset and Clock Enable
  - Four Dedicated Clock Input Pins Plus Macrocell Product Term Clocks
  - Slew and Skew Programmable I/O (SASPI/O) Supports Programmable Bus Hold, Pull-up, Open Drain and Slew and Skew Rate Options
  - Six Global Output Enable Terms, Two Global OE Pins and One Product Term OE per Macrocell
  - PC and UNIX Platforms

## Functional Block Diagram

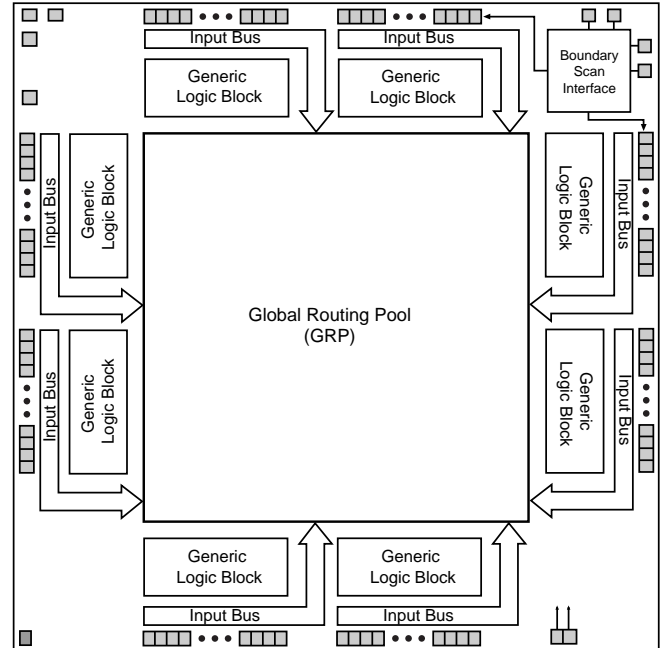

## ispLSI 5000V Description

The ispLSI 5000V Family of In-System Programmable High Density Logic Devices is based on Generic Logic Blocks (GLBs) of 32 registered macrocells and a single Global Routing Pool (GRP) structure interconnecting the GLBs.

Outputs from the GLBs drive the Global Routing Pool (GRP) between the GLBs. Switching resources are provided to allow signals in the Global Routing Pool to drive any or all the GLBs in the device. This mechanism allows fast, efficient connections across the entire device.

Each GLB contains 32 macrocells and a fully populated, programmable AND-array with 160 logic product terms and five extra control product terms. The GLB has 68 inputs from the Global Routing Pool which are available in both true and complement form for every product term. The 160 product terms are grouped in 32 sets of five and sent into a Product Term Sharing Array (PTSA) which allows sharing up to a maximum of 35 product terms for a single function. Alternatively, the PTSA can be bypassed for functions of five product terms or less. The

**Functional Block Diagram**

**Figure 1. ispLSI 5256VA Functional Block Diagram (272 BGA Option)**

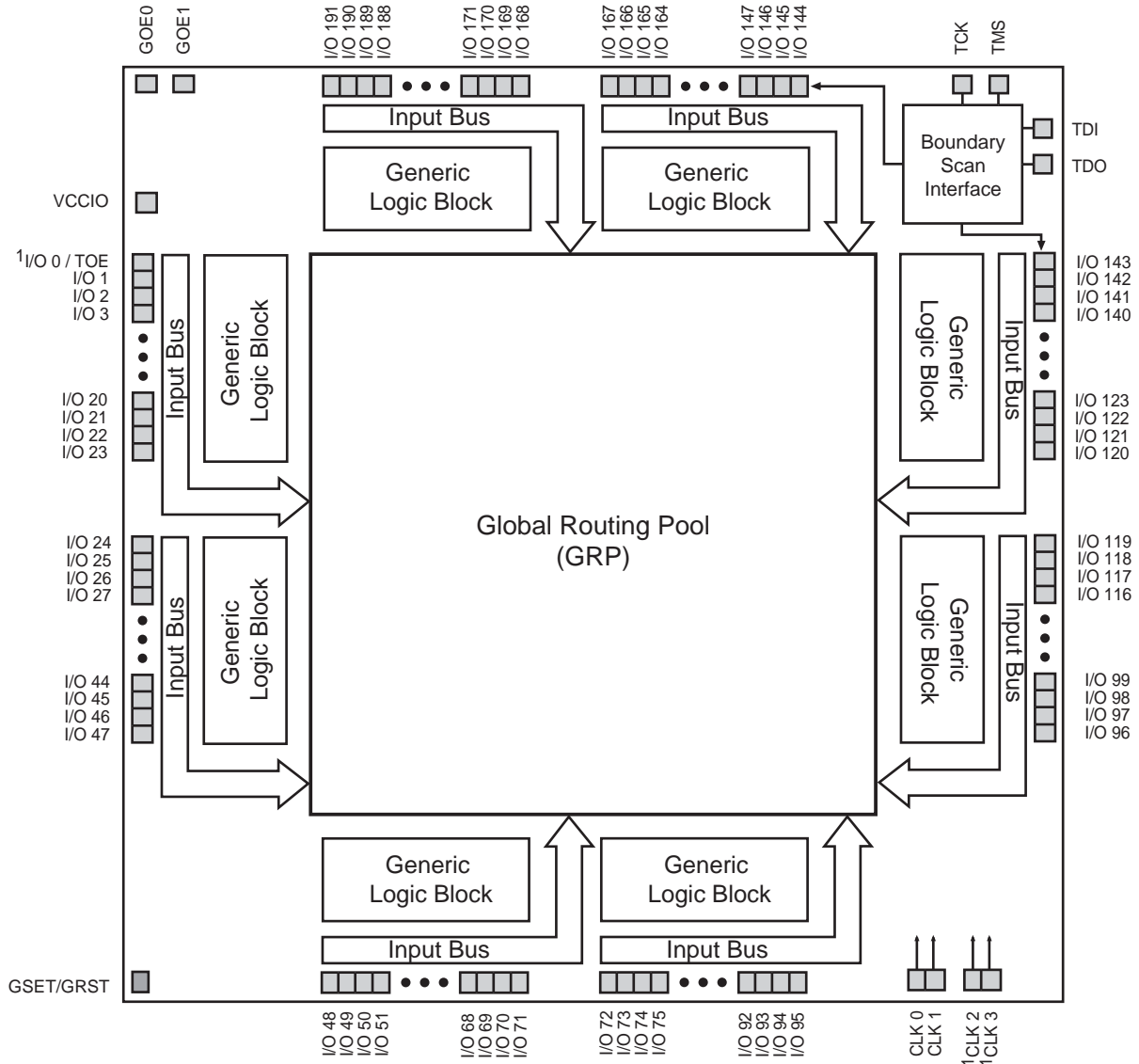

1. CLK2, CLK3 and TOE signals are multiplexed with I/O signals. Which I/O is multiplexed is determined by the package type used (see table below).

Package Type	Multiplexed Signals		
208 PQFP	I/O 89 / CLK2	I/O 98 / CLK3	I/O 0 / TOE
208 fpBGA	I/O 89 / CLK2	I/O 98 / CLK3	I/O 0 / TOE
272 BGA	I/O 119 / CLK2	I/O 131 / CLK3	I/O 0 / TOE

## ispLSI 5000V Description (Continued)

five extra product terms are used for shared GLB controls, set, reset, clock, clock enable and output enable.

The 32 registered macrocells in the GLB are driven by the 32 outputs from the PTSA or the PTSA bypass. Each macrocell contains a programmable XOR gate, a programmable register/latch/toggle flip-flop and the necessary clocks and control logic to allow combinatorial or registered operation. The macrocells each have two outputs, which can be fed back through the Global Routing Pool. This dual output capability from the macrocell allows efficient use of the hardware resources. One output can be a registered function for example, while the other output can be an unrelated combinatorial function. A direct register input from the I/O pad facilitates efficient use of this feature to construct high-speed input registers.

Macrocell registers can be clocked from one of several global or product term clocks available on the device. A global and product term clock enable is also provided, eliminating the need to gate the clock to the macrocell registers. Reset and preset for the macrocell register is provided from both global and product term signals. The macrocell register can be programmed to operate as a D-type register, a D-type latch or a T-type flip flop.

The 32 outputs from the GLB can drive both the Global Routing Pool and the device I/O cells. The Global Routing Pool contains one line from each macrocell output and one line from each I/O pin.

The input buffer threshold has programmable TTL/3.3V/2.5V compatible levels. The output driver can source 4mA and sink 8mA in 3.3V mode. The output drivers have a separate VCCIO reference input which is independent of the main VCC supply for the device. This feature allows the output drivers to drive either 3.3V or 2.5V output levels while the device logic and the output current drive is always powered from 3.3V. The output drivers also provide individually programmable edge

rates and open drain capability. A programmable pullup resistor is provided to tie off unused inputs and a programmable bus-hold latch is available to hold tristate outputs in their last valid state until the bus is driven again by some device.

The ispLSI 5000V Family features 3.3V, non-volatile in-system programmability for both the logic and the interconnect structures, providing the means to develop truly reconfigurable systems. Programming is achieved through the industry standard IEEE 1149.1-compliant Boundary Scan interface. Boundary Scan test is also supported through the same interface.

An enhanced, multiple cell security scheme is provided that prevents reading of the JEDEC programming file when secured. After the device has been secured using this mechanism, the only way to clear the security is to execute a bulk-erase instruction.

## ispLSI 5000V Family Members

The ispLSI 5000V Family ranges from 256 macrocells to 512 macrocells and operates from a 3.3V power supply. All family members will be available with multiple package options. The ispLSI 5000V Family device matrix showing the various bondout options is shown in the table below.

The interconnect structure (GRP) is very similar to Lattice's existing ispLSI 1000, 2000 and 3000 families, but with an enhanced interconnect structure for optimal pin locking and logic routing. This eliminates the need for registered I/O cells or an Output Routing Pool.

**Table 1. ispLSI 5000V Family**

Device	GLBs	Macrocells	Package Type			
			208 fpBGA	208 PQFP	272 BGA	388 BGA
ispLSI 5256VA	8	256	144 I/O	144 I/O	192 I/O	—
ispLSI 5384VA	12	384	144 I/O	144 I/O	192 I/O	288 I/O
ispLSI 5512VA	16	512	—	144 I/O	192 I/O	288 I/O

Figure 2. ispLSI 5256VA Block Diagram (192 I/O Version)

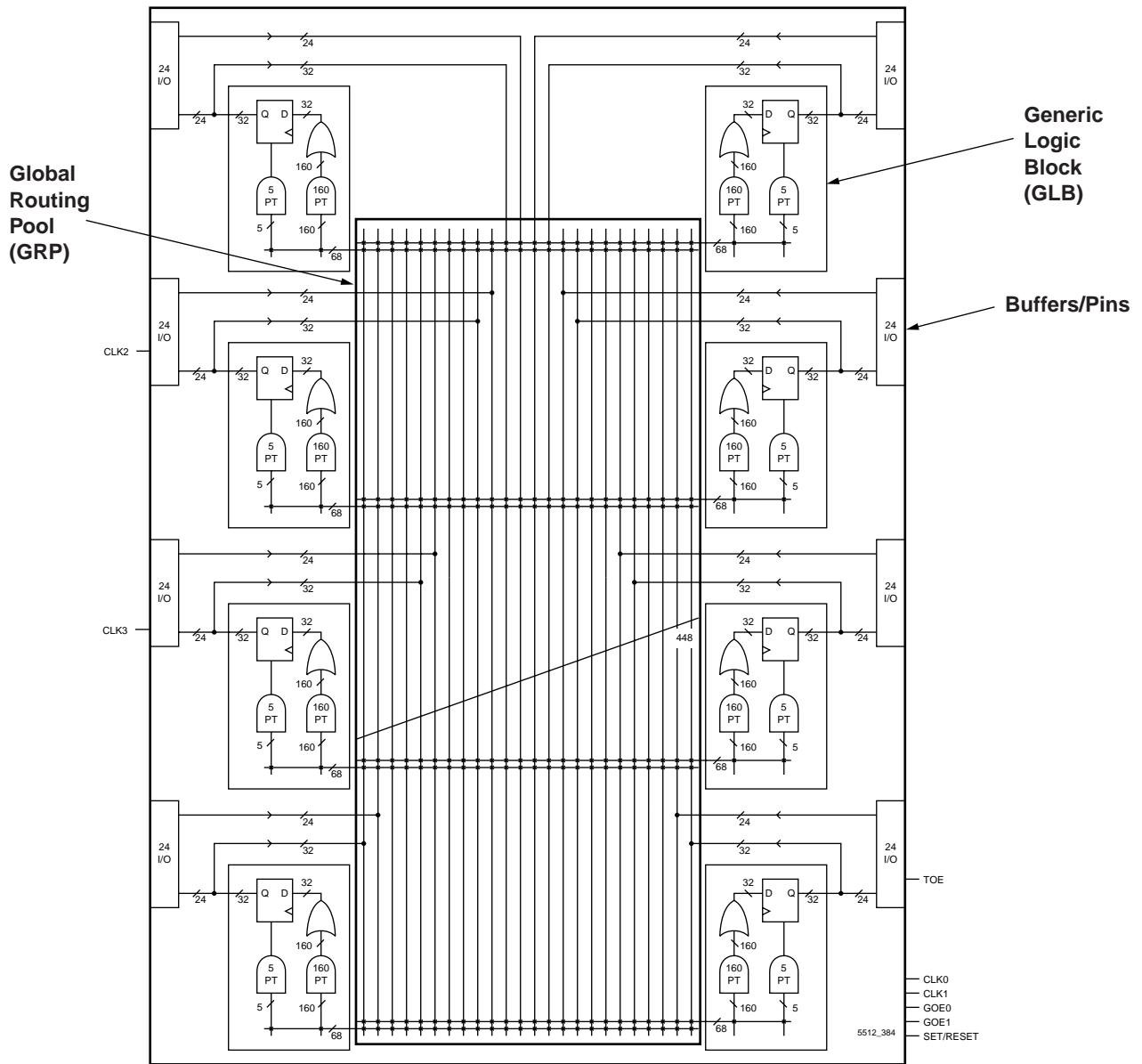

Figure 3. ispLSI 5000V Generic Logic Block (GLB)

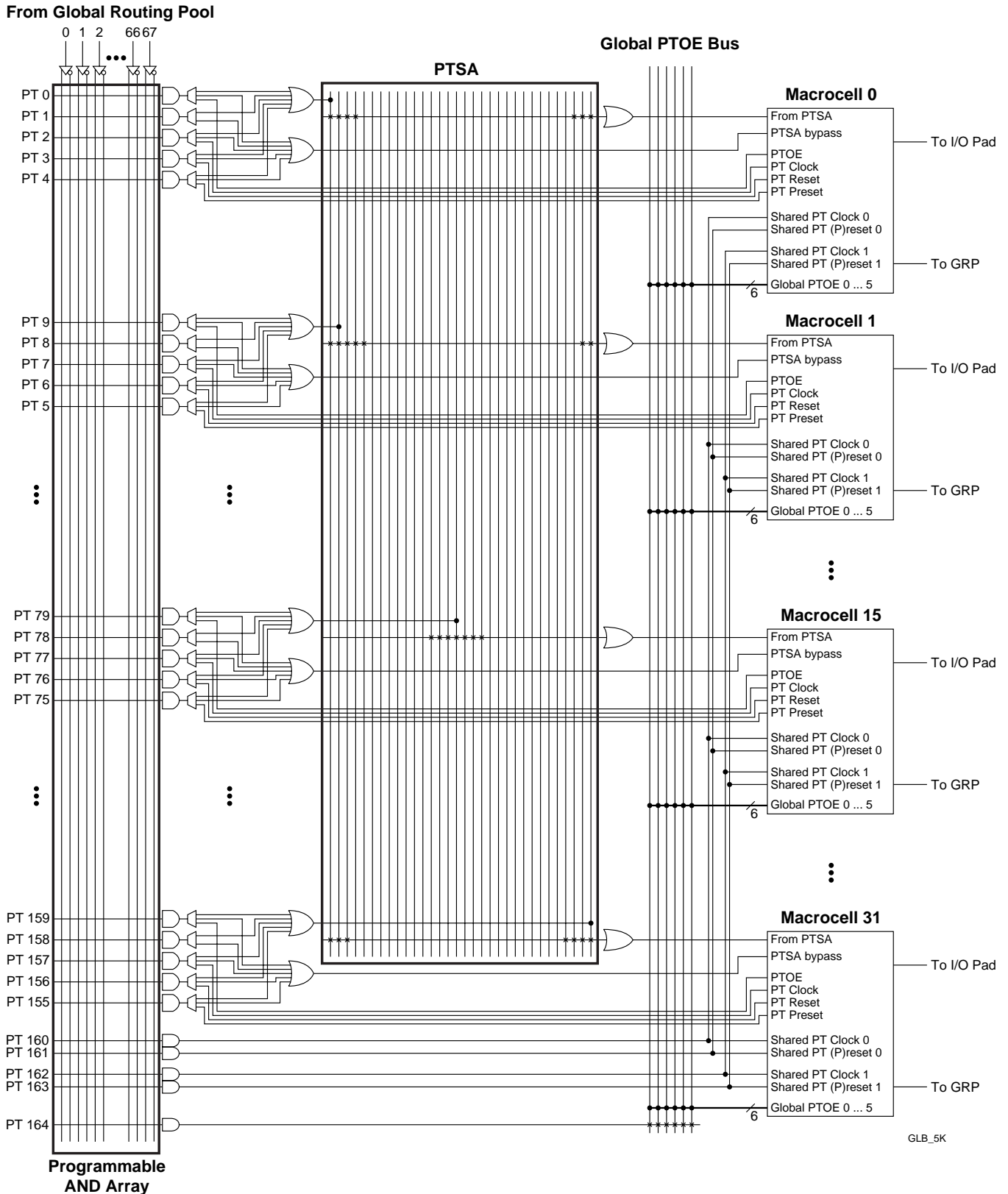
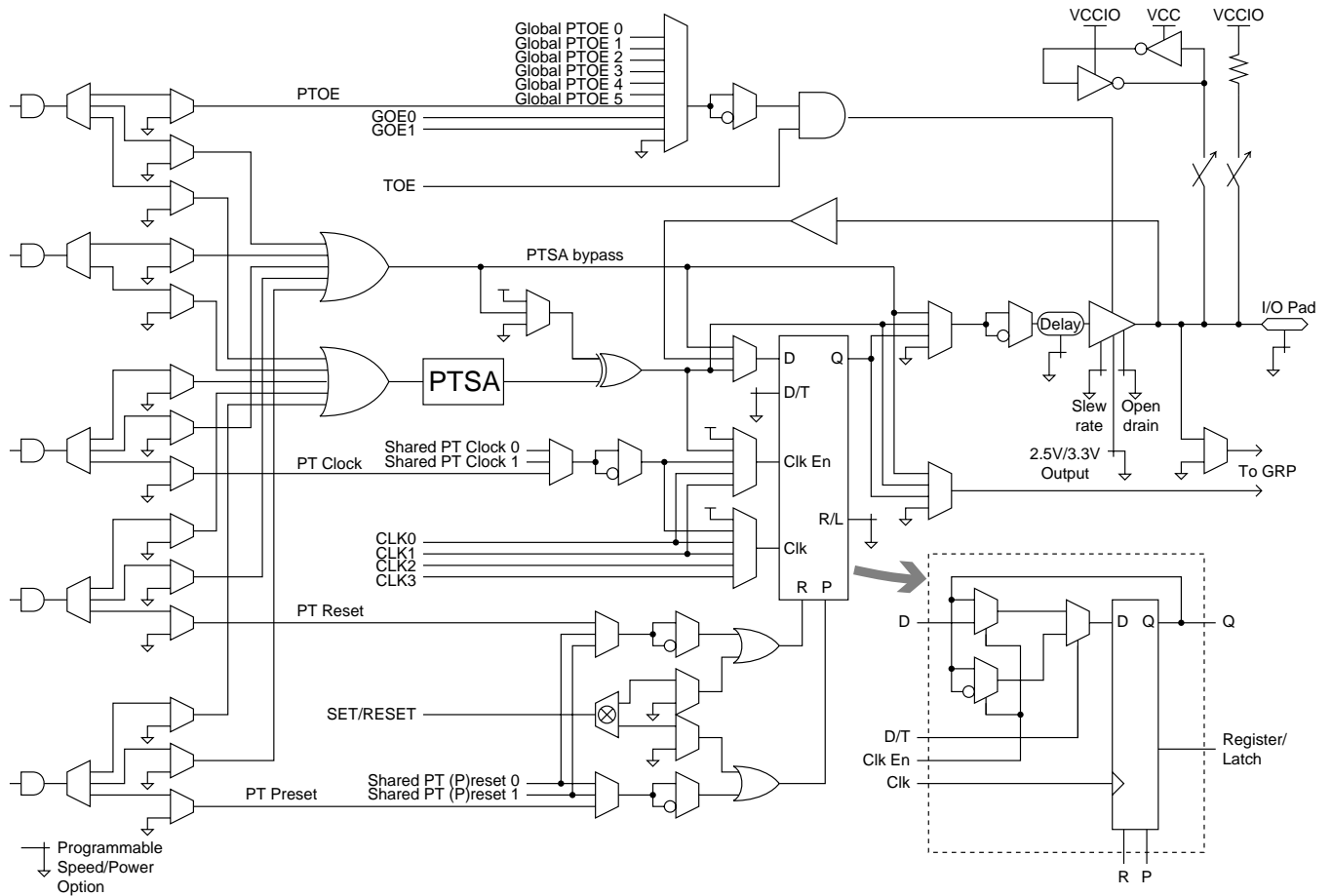

Figure 4. ispLSI 5000V Macrocell



**Global Clock Distribution**

The ispLSI 5000V Family has four dedicated clock input pins: CLK0 - CLK3. CLK0 input is used as the dedicated master clock that has the lowest internal clock skew with no clock inversion to maintain the fastest internal clock

speed. The clock inversion is available on the remaining CLK1 - CLK3 signals. By sharing the pins with the I/O pins, CLK2 and CLK3 can not only be inverted but also is available for logic implementation through GRP signal routing. Figure 5 shows these different clock distribution options.

**Figure 5. ispLSI 5000V Global Clock Structure**

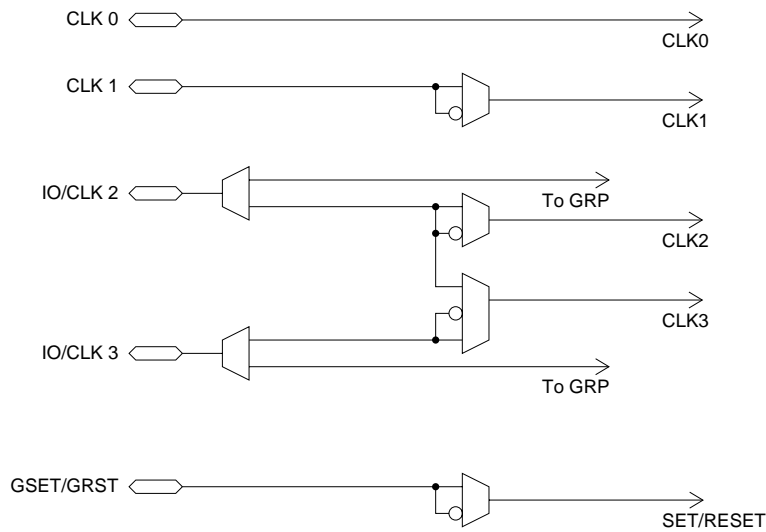

Figure 6. Boundary Scan Register Circuit for I/O Pins

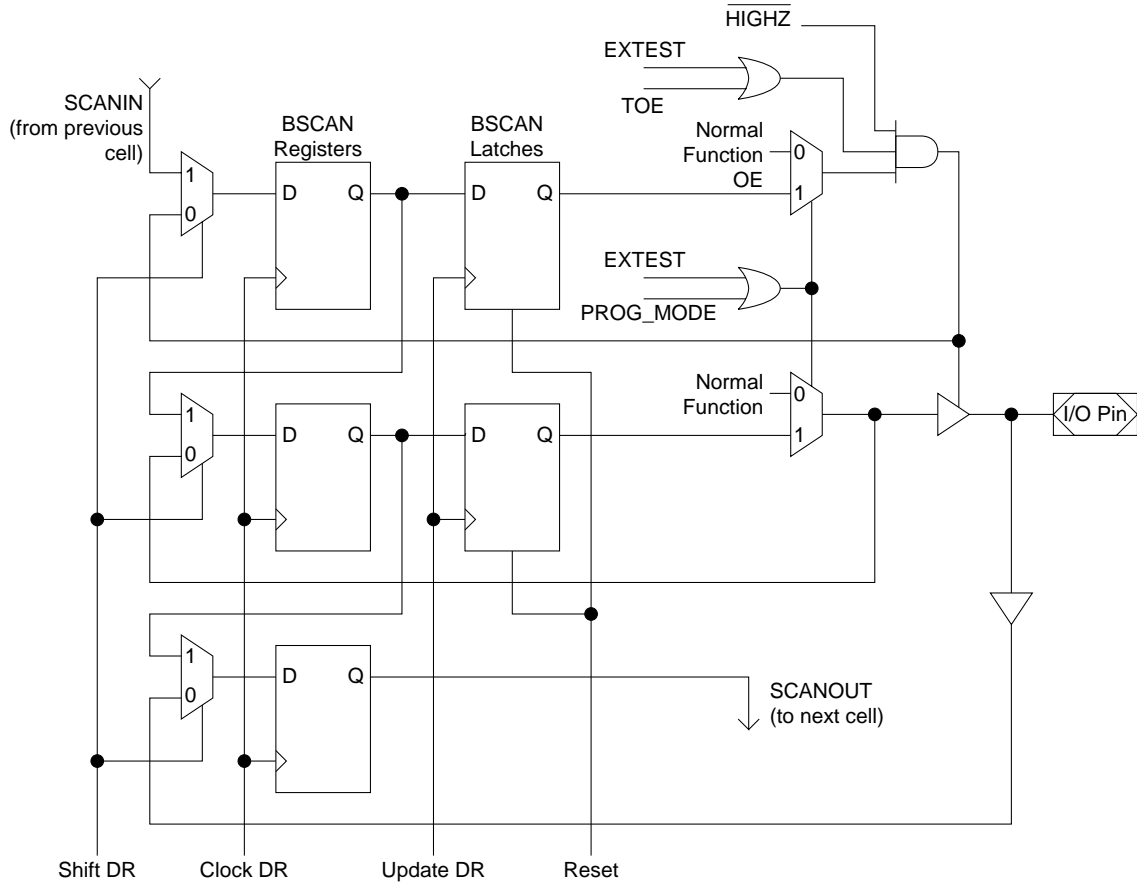
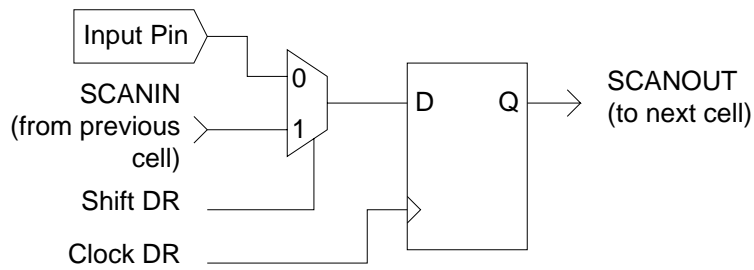
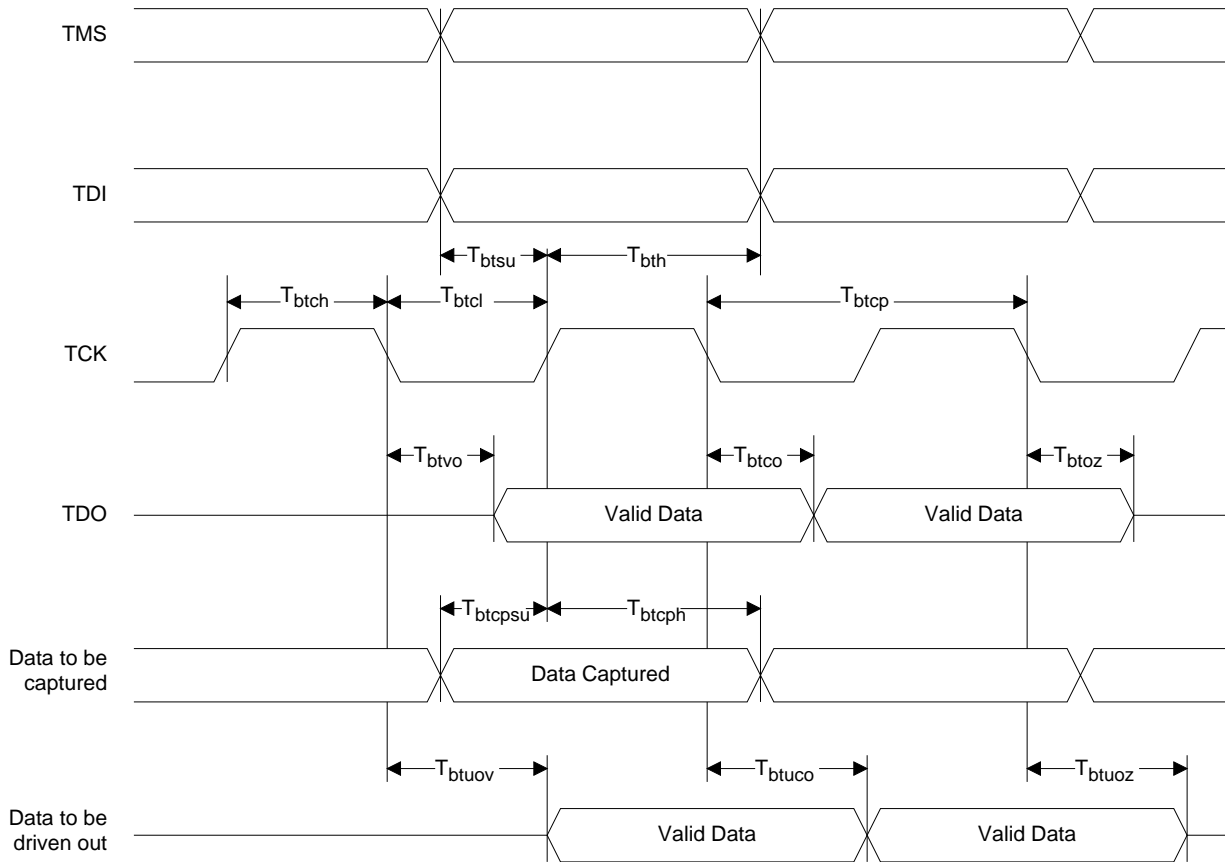

Figure 7. Boundary Scan Register Circuit for Input-Only Pins





**Figure 8. Boundary Scan Waveforms and Timing Specifications**



SYMBOL	PARAMETER	MIN	MAX	UNITS
$t_{btcp}$	TCK [BSCAN test] clock pulse width	125	–	ns
$t_{btch}$	TCK [BSCAN test] pulse width high	62.5	–	ns
$t_{btcl}$	TCK [BSCAN test] pulse width low	62.5	–	ns
$t_{btsu}$	TCK [BSCAN test] setup time	25	–	ns
$t_{bth}$	TCK [BSCAN test] hold time	25	–	ns
$t_{rf}$	TCK [BSCAN test] rise and fall time	50	–	mV/ns
$t_{btco}$	TAP controller falling edge of clock to valid output	–	25	ns
$t_{btoz}$	TAP controller falling edge of clock to data output disable	–	25	ns
$t_{btvo}$	TAP controller falling edge of clock to data output enable	–	25	ns
$t_{btcpu}$	BSCAN test Capture register setup time	25	–	ns
$t_{btcpu}$	BSCAN test Capture register hold time	25	–	ns
$t_{btuo}$	BSCAN test Update reg, falling edge of clock to valid output	–	50	ns
$t_{btuo}$	BSCAN test Update reg, falling edge of clock to output disable	–	50	ns
$t_{btuo}$	BSCAN test Update reg, falling edge of clock to output enable	–	50	ns

## Absolute Maximum Ratings <sup>1, 2</sup>

Supply Voltage  $V_{CC}$  ..... -0.5 to +5.4V  
 Input Voltage Applied ..... -0.5 to +5.6V  
 Tri-Stated Output Voltage Applied ..... -0.5 to +5.6V  
 Storage Temperature ..... -65 to 150°C  
 Case Temp. with Power Applied ..... -55 to 125°C  
 Max. Junction Temp. ( $T_J$ ) with Power Applied ... 150°C

1. Stresses above those listed under the “Absolute Maximum Ratings” may cause permanent damage to the device. Functional operation of the device at these or at any other conditions above those indicated in the operational sections of this specification is not implied (while programming, follow the programming specifications).
2. Compliance with the Thermal Management section of the Lattice Semiconductor Data Book or CD-ROM is a requirement.

## DC Recommended Operating Condition

SYMBOL	PARAMETER	MIN.	MAX.	UNITS	
$V_{CC}$	Supply Voltage	Commercial $T_A = 0^\circ\text{C}$ to $+70^\circ\text{C}$	3.00	3.60	V
		Industrial $T_A = -40^\circ\text{C}$ to $+85^\circ\text{C}$	3.00	3.60	V
$V_{CCIO}$	I/O Reference Voltage	2.3	3.60	V	

Table 2 - 0005/5256

## Capacitance ( $T_A=25^\circ\text{C}, f=1.0\text{ MHz}$ )

SYMBOL	PARAMETER	TYPICAL	UNITS	TEST CONDITIONS
$C_1$	I/O Capacitance	10	pf	$V_{CC} = 3.3\text{V}, V_{I/O} = 2.0\text{V}$
$C_2$	Clock Capacitance	10	pf	$V_{CC} = 3.3\text{V}, V_{CK} = 2.0\text{V}$
$C_3$	Global Input Capacitance	10	pf	$V_{CC} = 3.3\text{V}, V_G = 2.0\text{V}$

Table 2 - 0006/5384

## Erase Reprogram Specification

PARAMETER	MINIMUM	MAXIMUM	UNITS
ispLSI Erase/Reprogram Cycles	10000	–	Cycles

Table 2-0008/3320

**Switching Test Conditions**

Input Pulse Levels	GND to $V_{CCIO_{min}}$
Input Rise and Fall Time	$\leq 1.5ns$ 10% to 90%
Input Timing Reference Levels	1.5V
Output Timing Reference Levels	1.5V
Output Load	See figure

3-state levels are measured 0.5V from steady-state active level. Table 2 - 0003/5384

**Output Load Conditions (See Figure 8)**

		3.3V		2.5V		
TEST CONDITION		R1	R2	R1	R2	CL
A		316Ω	348Ω	511Ω	475Ω	35pF
B	Active High	∞	348Ω	∞	475Ω	35pF
	Active Low	316Ω	∞	511Ω	∞	35pF
C	Active High to Z at $V_{OH}-0.5V$	∞	348Ω	∞	475Ω	5pF
	Active Low to Z at $V_{OL}+0.5V$	316Ω	∞	511Ω	∞	5pF
D	Slow Slew	∞	∞	∞	∞	35pF

Table 2 - 0004A/5384

**Figure 9. Test Load**

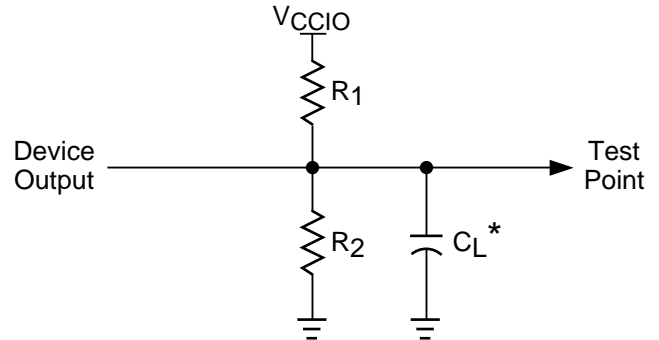

\* $C_L$  includes Test Fixture and Probe Capacitance.

0213D

**DC Electrical Characteristics for 3.3V Range<sup>1</sup>**

**Over Recommended Operating Conditions**

SYMBOL	PARAMETER	CONDITION	MIN.	TYP.	MAX.	UNITS
$V_{CCIO}$	I/O Reference Voltage		3.0	–	3.6	V
$V_{IL}$	Input Low Voltage	$V_{OH} \leq V_{OUT}$ or $V_{OUT} \leq V_{OL(max)}$	-0.3	–	0.8	V
$V_{IH}$	Input High Voltage	$V_{OH} \leq V_{OUT}$ or $V_{OUT} \leq V_{OL(max)}$	2.0	–	5.25	V
$V_{OL}$	Output Low Voltage	$I_{OL} = 8\text{ mA}$	–	–	0.4	V
$V_{OH}$	Output High Voltage	$I_{OH} = -4\text{ mA}$	2.4	–	–	V

Table 2-0007/5256VA

1. I/O voltage configuration must be set to VCC.

## DC Electrical Characteristics for 2.5V Range<sup>1</sup>

### Over Recommended Operating Conditions

SYMBOL	PARAMETER	CONDITION	MIN.	TYP.	MAX.	UNITS
V <sub>CCIO</sub>	I/O Reference Voltage		2.3	–	2.7	V
V <sub>IL</sub>	Input Low Voltage	$V_{OH(min)} \leq V_{OUT}$ or $V_{OUT} \leq V_{OL(max)}$	-0.3	–	0.7	V
V <sub>IH</sub>	Input High Voltage	$V_{OH(min)} \leq V_{OUT}$ or $V_{OUT} \leq V_{OL(max)}$	1.7	–	5.25	V
V <sub>OL</sub>	Output Low Voltage	$V_{CCIO=min}, V_{IN}=V_{IH}$ or $V_{IL}, I_{OL}=100\mu A$	–	–	0.2	V
		$V_{CCIO=min}, V_{IN}=V_{IH}$ or $V_{IL}, I_{OL}=2mA$	–	–	0.7	V
V <sub>OH</sub>	Output High Voltage	$V_{CCIO=min}, V_{IN}=V_{IH}$ or $V_{IL}, I_{OH}=-100\mu A$	2.1	–	–	V
		$V_{CCIO=min}, V_{IN}=V_{IH}$ or $V_{IL}, I_{OH}=-2mA$	1.7	–	–	V

1. I/O voltage configuration must be set to V<sub>CCIO</sub>.

2.5V/5256VA

## DC Electrical Characteristics

### Over Recommended Operating Conditions

SYMBOL	PARAMETER	CONDITION	MIN.	TYP.	MAX.	UNITS
I <sub>IL</sub>	Input or I/O Low Leakage Current	$0V \leq V_{IN} \leq V_{IL(Max.)}$	–	–	-10	$\mu A$
I <sub>IH</sub>	Input or I/O High Leakage Current	$(V_{CCIO}-0.2)V \leq V_{IN} \leq V_{CCIO}$	–	–	10	$\mu A$
		$V_{CCIO} \leq V_{IN} \leq 5.25V$	–	–	50	$\mu A$
I <sub>PU</sub> <sup>1</sup>	I/O Active Pullup Current	$0V \leq V_{IN} \leq V_{IL}$	–	–	-150	$\mu A$
I <sub>BHL</sub>	Bus Hold Low Sustaining Current	$V_{IN} = V_{IL(max)}$	40	–	–	$\mu A$
I <sub>BHH</sub>	Bus Hold High Sustaining Current	$V_{IN} = V_{IH(min)}$	-40	–	–	$\mu A$
I <sub>BHLO</sub>	Bus Hold Low Overdrive Current	$0V \leq V_{IN} \leq V_{CCIO}$	–	–	550	$\mu A$
I <sub>BHLH</sub>	Bus Hold High Overdrive Current	$0V \leq V_{IN} \leq V_{CCIO}$	–	–	-550	$\mu A$
I <sub>BHT</sub>	Bus Hold Trip Points		V <sub>IL</sub>	–	V <sub>IH</sub>	V
I <sub>VCCIO</sub>	Current Needed for V <sub>CCIO</sub> Pin	All I/Os Pulled-up, (Total I/Os * I <sub>PUmax</sub> )	–	–	30	mA

1. Pullup is capable of pulling to a minimum voltage of V<sub>OH</sub> under no-load conditions.

DC Char\_5256VA

## External Switching Characteristics

### Over Recommended Operating Conditions

PARAM.	TEST <sup>3</sup> COND.	#	DESCRIPTION <sup>4,5</sup>	-125		-100		-70		UNITS
				MIN.	MAX.	MIN.	MAX.	MIN.	MAX.	
t <sub>pd1</sub> <sup>6</sup>	A	1	Data Prop. Delay, 5PT Bypass	—	7.5	—	10	—	15	ns
t <sub>pd2</sub> <sup>6</sup>	A	2	Data Propagation Delay	—	9.5	—	13	—	19	ns
f <sub>max</sub>	A	3	Clock Frequency with Internal Feedback <sup>1</sup>	125	—	100	—	70	—	MHz
f <sub>max</sub> (Ext.)	—	4	Clock Freq. with Ext. Feedback, 1/(tsu2 + tco1)	91	—	69	—	45	—	MHz
f <sub>max</sub> (Tog.)	—	5	Clock Frequency, Max Toggle <sup>2</sup>	167	—	125	—	83	—	MHz
t <sub>su1</sub>	—	6	GLB Reg. Setup Time before Clk, 5PT bypass	6	—	8	—	12	—	ns
t <sub>co1</sub> <sup>6</sup>	A	7	GLB Reg. Clock to Output Delay	—	4	—	5.5	—	8	ns
t <sub>h1</sub>	—	8	GLB Reg. Hold Time after Clock, 5PT bypass	0	—	0	—	0	—	ns
t <sub>su2</sub>	—	9	GLB Reg. Setup Time before Clock	7	—	9	—	14	—	ns
t <sub>h2</sub>	—	10	GLB Reg. Hold Time after Clock	0	—	0	—	0	—	ns
t <sub>su3</sub> (CLK0/1)	—	11	GLB Reg. Setup Time before Clock, Input Reg. Path (CLK0/1)	4.5	—	6	—	9	—	ns
t <sub>su3</sub> (CLK2/3)	—	12	GLB Reg. Setup Time before Clock, Input Reg. Path (CLK2/3)	3.5	—	5	—	7	—	ns
t <sub>h3</sub> (CLK0/1)	—	13	GLB Reg. Hold Time after Clock, Input Reg. Path (CLK0/1)	0	—	0	—	0	—	ns
t <sub>h3</sub> (CLK2/3)	—	14	GLB Reg. Hold Time after Clock, Input Reg. Path (CLK2/3)	0	—	0	—	0	—	ns
t <sub>r1</sub>	A	15	Ext. Reset Pin to Output Delay	—	15	—	20	—	30	ns
t <sub>rw1</sub>	—	16	Ext. Reset Pulse Duration	7	—	9	—	14	—	ns
t <sub>ptoe/dis</sub>	B/C	17	Local Product Term Output Enable/Disable	—	9	—	12	—	18	ns
t <sub>gptoe/dis</sub>	B/C	18	Global Product Term Output Enable/Disable	—	18	—	24	—	30	ns
t <sub>goe/dis</sub>	B/C	19	Global OE Input to Output Enable/Disable	—	6	—	8	—	12	ns
t <sub>wh</sub>	—	20	Ext. Sync. Clock Pulse Duration, High	3	—	4	—	6	—	ns
t <sub>wl</sub>	—	21	Ext. Sync. Clock Pulse Duration, Low	3	—	4	—	6	—	ns

1. Standard 32-bit counter using GRP feedback.

2. f<sub>max</sub> (Toggle) may be less than 1/(t<sub>wh</sub> + t<sub>wl</sub>). This is to allow for a clock duty cycle of other than 50%.

3. Reference Switching Test Conditions section.

4. Unless noted otherwise, all timing numbers are taken with worst case PTSA fanout, a GRP load of 1 GLB, and CLK0.

5. Timing parameters measured using normal active output driver.

6. The delay parameters are measured with V<sub>cc</sub> as I/O voltage reference. An additional 0.5ns delay is incurred when V<sub>ccio</sub> is used as I/O voltage reference.

Timing Ext.5256va/4.0.eps

## Internal Timing Parameters<sup>1</sup>

### Over Recommended Operating Conditions

PARAM	# <sup>2</sup>	DESCRIPTION	-125		-100		-70		UNIT
			MIN	MAX	MIN	MAX	MIN	MAX	
<b>I/O Buffer</b>									
tidcom	22	Input Pad and Buffer, Combinatorial Input	–	0.7	–	0.9	–	1.4	ns
tidreg	23	Input Pad and Buffer, Registered Input	–	4.7	–	6.6	–	9.7	ns
todcom	24	Output Pad and Buffer, Combinatorial Output	–	1.3	–	1.7	–	2.6	ns
todreg	25	Output Pad and Buffer, Registered Output	–	1.8	–	2.8	–	4.6	ns
todz	26	Output Buffer Enable/Disable	–	1.3	–	1.7	–	2.6	ns
tslf	27	Slew Rate Adder, Fast Slew	–	0	–	0	–	0	ns
tsls	28	Slew Rate Adder, Slow Slew	–	7.5	–	10	–	15	ns
tslfd	29	Programmable Delay Adder, Fast Slew	–	0.5	–	0.7	–	1	ns
tslsd	30	Programmable Delay Adder, Slow Slew	–	8	–	10.7	–	16	ns
<b>GLB/Macrocell Delay Register</b>									
tmbp	31	Macrocell Register/Latch Bypass	–	0	–	0	–	0	ns
tmlat	32	Macrocell Latch Delay	–	1	–	1.4	–	2	ns
tmco	33	Macrocell Register/Latch Clock to Output	–	1	–	1	–	1	ns
tmsu	34	Macrocell Register/Latch Setup Time	1	–	1.1	–	1.7	–	ns
tmh	35	Macrocell Register/Latch Hold Time	2.5	–	3.9	–	5.3	–	ns
tmsuce	36	Macrocell Register/Latch CLKEN Setup Time	1	–	1.4	–	2	–	ns
tmhce	37	Macrocell Register/Latch CLKEN Hold Time	1	–	1.4	–	2	–	ns
tmrst	38	Macrocell Register/Latch Set/Reset Time	–	1	–	1.4	–	2	ns
tftog	39	Toggle Flip-Flop Feedback	–	1	–	1.3	–	2	ns
<b>AND Array</b>									
tandhs	40	AND Array, High Speed Mode	–	3	–	4	–	6	ns
tandlp	41	AND Array, Low Power Mode	–	5	–	6.6	–	10	ns
<b>PTSA</b>									
t5ptcom	42	5 Product Term Bypass, Combinatorial	–	1	–	1.4	–	2	ns
t5ptreg	43	5 Product Term Bypass, Registered	–	1	–	1.7	–	2.3	ns
t5ptxcom	44	5 Product Term XOR, Combinatorial	–	2.5	–	3.6	–	5	ns
t5ptxreg	45	5 Product Term XOR, Registered	–	1.5	–	2.2	–	3.3	ns
tptsacom	46	Product Term Sharing Array, Combinatorial	–	3	–	4.1	–	6	ns
tptsareg	47	Product Term Sharing Array, Registered	–	2.0	–	2.7	–	4.3	ns
<b>PTSA Controls</b>									
tpck	48	Product Term Clock Delay	–	0.5	–	0.7	–	1	ns
tpcken	49	Product Term CLKEN Delay	–	1	–	1.4	–	2	ns
tscken	50	Shared Product Term CLKEN Delay	–	1	–	1.4	–	2	ns
tsck	51	Shared Product Term Clock Delay	–	0.5	–	0.7	–	1	ns
tptsacken	52	Product Term Sharing Array CLKEN Delay	–	2.0	–	2.4	–	4	ns
tsrst	53	Shared Product Term Set/Reset Delay	–	2.5	–	3.4	–	5	ns
tprst	54	Product Term Set/Reset Delay	–	1.5	–	2	–	3	ns
tpoe	55	Product Term Output Enable/Disable	–	2.5	–	3.4	–	5	ns
tgpoe	56	Global PT Output Enable/Disable	–	11.5	–	15.4	–	17	ns

1. Internal Timing Parameters are not tested and are for reference only.  
 2. Refer to Timing Model in this data sheet for further details.

**Internal Timing Parameters<sup>1</sup>**

**Over Recommended Operating Conditions**

PARAM	# <sup>2</sup>	DESCRIPTION	-125		-100		-70		UNIT
			MIN	MAX	MIN	MAX	MIN	MAX	
GRP									
tgrpi	57	GRP Delay from I/O Pad	–	1.5	–	2	–	3	ns
tgrpm	58	GRP Delay from Macrocell	–	1.0	–	1.2	–	1.2	ns
Global Control Delays									
tgclk01	59	Global Clock 0 or 1 Delay	–	1.2	–	1.7	–	2.4	ns
tgclk23	60	Global Clock 2 or 3 Delay	–	2.2	–	2.7	–	4.4	ns
tgclken0	61	Global CLKEN 0 Delay	–	1.7	–	2.4	–	3.4	ns
tgclken1	62	Global CLKEN 1 Delay	–	2.7	–	3.4	–	5.4	ns
tgrst	63	Global Set/Reset Delay	–	12.2	–	15.8	–	23.4	ns
tgoe	64	Global OE Delay	–	4.7	–	6.3	–	9.4	ns
ttoe	65	Test OE Delay	–	4.7	–	6.2	–	9.4	ns

1. Internal Timing Parameters are not tested and are for reference only.

Timing Rev. 4.0

2. Refer to Timing Model in this data sheet for further details.

**ispLSI 5256VA Timing Model**

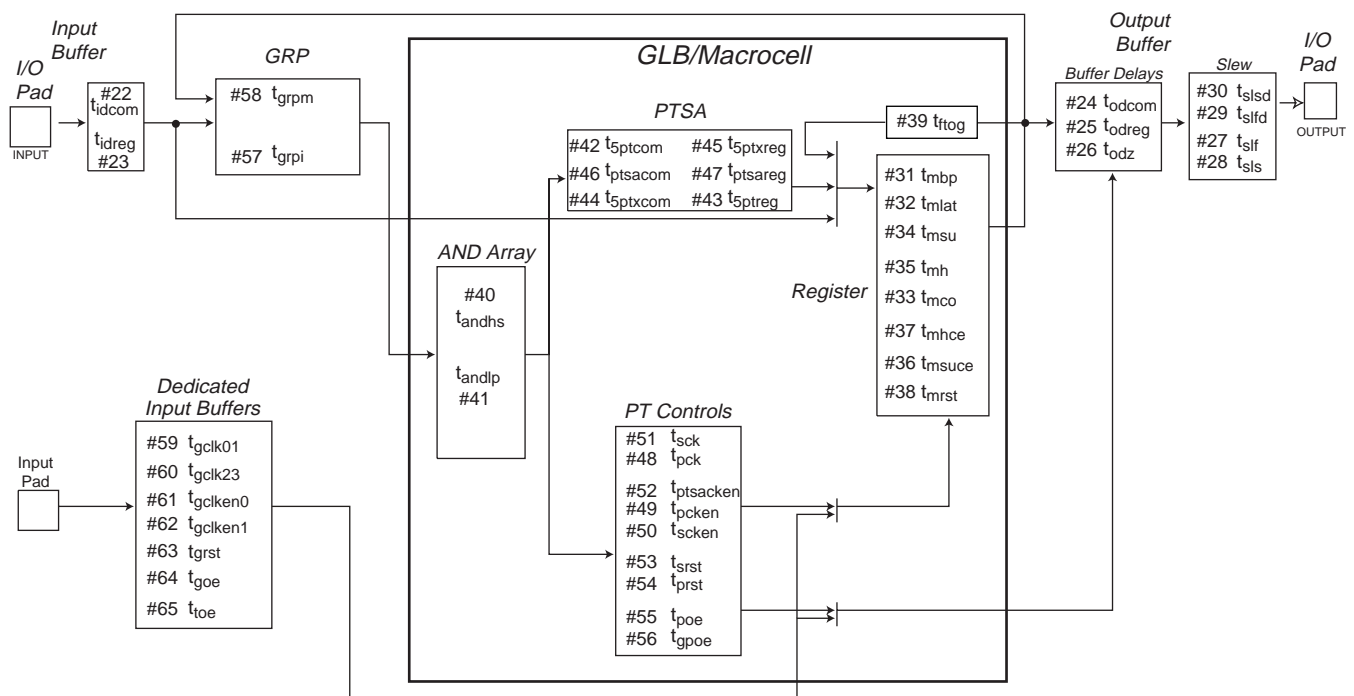

**Power Consumption**

Power consumption in the ispLSI 5256VA device depends on two primary factors: the speed at which the device is operating and the number of product terms used. The product terms have a fuse-selectable speed/power tradeoff setting. Each group of four product terms has a single speed/power tradeoff control fuse that acts

on the complete group of four. The fast “high-speed” setting operates product terms at their normal full power consumption. For portions of the logic that can tolerate longer propagation delays, selecting the slower “low-power” setting will significantly reduce the power dissipation for these product terms. Figure 10 shows the relationship between power and operating speed.

**Figure 10. Typical Device Power Consumption vs fmax**

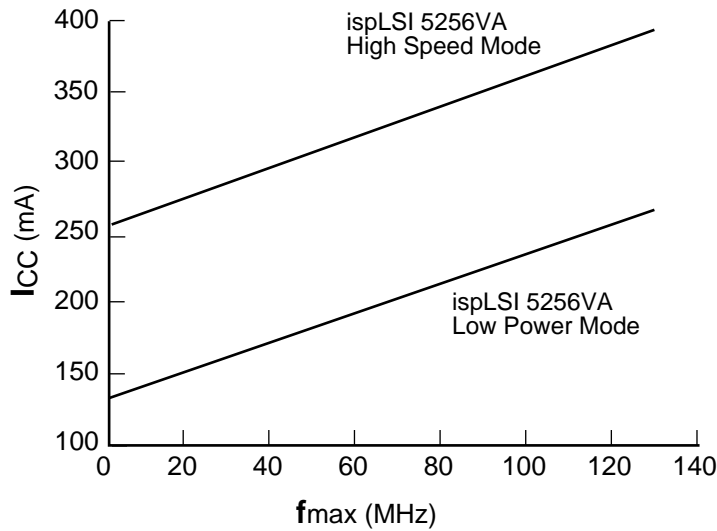

Notes: Configuration of 16 16-bit Counters  
Typical Current at 3.3V, 25° C

ICC can be estimated for the ispLSI 5256VA using the following equation:

**High Speed Mode:**  $ICC = 30 + (\# \text{ of PTs} * 0.456) + (\# \text{ of nets} * \text{Max. freq} * 0.0039)$

**Low Power Mode:**  $ICC = 30 + (\# \text{ of PTs} * 0.22) + (\# \text{ of nets} * \text{Max. freq} * 0.0039)$

# of PTs = Number of Product Terms used in design

# of nets = Number of Signals used in device

Max. freq = Highest Clock Frequency to the device

The ICC estimate is based on typical conditions (VCC = 3.3V, room temperature) and an assumption of 2 GLB loads on average exists. These values are for estimates only. Since the value of ICC is sensitive to operating conditions and the program in the device, the actual ICC should be verified.

0127/5256va



## Signal Descriptions

Signal Name	Description
TMS	Input - This pin is the Test Mode Select input, which is used to control the JTAG state machine.
TCK	Input - This pin is the Test Clock input pin used to clock through the JTAG state machine.
TDI	Input - This pin is the JTAG Test Data In pin used to load data.
TDO	Output - This pin is the JTAG Test Data Out pin used to shift data out.
TOE / I/O0	Input/Output - This pin functions as either the Test Output Enable pin or an I/O pin based upon customer's design. TOE tristates all I/O pins when a logic low is driven.
GOE0, GOE1	Input - These two pins are the Global Output Enable input pins.
GSET/GRST	Dedicated Set/Reset Input - This pin is available to all registers in the device and can independently be configured as preset, reset or no effect on each register. The global polarity (active high or low input) for this pin is also selectable.
I/O	Input/Output – These are the general purpose I/O used by the logic array.
GND	Ground
NC <sup>1</sup>	No connect.
VCC	Vcc
CLK0, CLK1	Dedicated clock inputs for all registers. Both clocks are muxed before being used as the clock input to all registers in the device.
CLK2 / I/O, CLK3 / I/O	Input/Output - These pins function as either dedicated clock inputs for all registers or an I/O pin based upon customer's design. Both clocks are muxed before being used as the clock input to all registers in the device.
VCCIO	Input - This pin is used if an optional 2.5V output is to be used. Every I/O can independently select either 3.3V or the optional voltage as its output level. If the optional output voltage is not required, this pin must be connected to the Vcc supply. Programmable pull-up resistors and bus-hold latches only draw current from this supply.

1. NC pins are not to be connected to any active signals, VCC or GND.

### 272-Ball BGA Signal Locations

Signal	Ball
GOE0, GOE1	V11, U11
TOE / I/O 0	M2
SET/RST	J18
TCK	L4
TDI	M1
TDO	J20
TMS	L3
CLK0, CLK1	C10, D10
CLK2 / I/O 119	A18
CLK3 / I/O 131	B13
VCCIO	J19
GND	A1, D4, D8, D13, D17, H4, H17, J9, J10, J11, J12, K9, K10, K11, K12, L9, L10, L11, L12, M9, M10, M11, M12, N4, N17, U4, U8, U13, U17
VCC	D6, D11, D15, F4, F17, K4, L17, R4, R17, U6, U10, U15
NC <sup>1</sup>	A17, B3, B18, B19, B20, C3, C5, C18, C19, D3, D19, E2, P19, R3, T4, T17, T20, U1, U2, U3, W1, W2, W4, W17, W19, W20, Y2, Y12, Y20,

1. NCs are not to be connected to any active signals, VCC or GND.

**272-Ball BGA I/O Locations (Sorted by I/O)**

I/O #	Ball	I/O #	Ball	I/O #	Ball	I/O #	Ball	I/O #	Ball	I/O #	Ball
0*	M2	32	W7	64	U16	96	J17	128	B14	160	A3
1	M3	33	Y7	65	V17	97	H20	129	A14	161	D5
2	M4	34	V8	66	W18	98	H19	130	C13	162	C4
3	N1	35	W8	67	Y19	99	H18	131*	B13	163	B2
4	N2	36	Y8	68	V18	100	G20	132	A13	164	A2
5	N3	37	U9	69	V19	101	G19	133	D12	165	B1
6	P1	38	V9	70	U19	102	F20	134	C12	166	C2
7	P2	39	W9	71	U18	103	G18	135	B12	167	D2
8	R1	40	Y9	72	V20	104	F19	136	A12	168	E4
9	P3	41	W10	73	U20	105	E20	137	B11	169	C1
10	R2	42	V10	74	T18	106	G17	138	C11	170	D1
11	T1	43	Y10	75	T19	107	F18	139	A11	171	E3
12	P4	44	Y11	76	R18	108	E19	140	A10	172	E1
13	T2	45	W11	77	P17	109	D20	141	B10	173	F3
14	T3	46	W12	78	R19	110	E18	142	A9	174	G4
15	V1	47	V12	79	R20	111	C20	143	B9	175	F2
16	V2	48	U12	80	P18	112	E17	144	C9	176	F1
17	V3	49	Y13	81	P20	113	D18	145	D9	177	G3
18	Y1	50	W13	82	N18	114	A20	146	A8	178	G2
19	W3	51	V13	83	N19	115	A19	147	B8	179	G1
20	V4	52	Y14	84	N20	116	B17	148	C8	180	H3
21	U5	53	W14	85	M17	117	C17	149	A7	181	H2
22	Y3	54	Y15	86	M18	118	D16	150	B7	182	H1
23	Y4	55	V14	87	M19	119*	A18	151	A6	183	J4
24	V5	56	W15	88	M20	120	C16	152	C7	184	J3
25	W5	57	Y16	89	L19	121	B16	153	B6	185	J2
26	Y5	58	U14	90	L18	122	A16	154	A5	186	J1
27	V6	59	V15	91	L20	123	C15	155	D7	187	K2
28	U7	60	W16	92	K20	124	D14	156	C6	188	K3
29	W6	61	Y17	93	K19	125	B15	157	B5	189	K1
30	Y6	62	V16	94	K18	126	A15	158	A4	190	L1
31	V7	63	Y18	95	K17	127	C14	159	B4	191	L2

\* I/O 119 is multiplexed with CLK2, I/O 131 is multiplexed with CLK3 and I/O 0 is multiplexed with TOE.

**272-Ball BGA I/O Locations (Sorted by Ball)**

I/O #	Ball	I/O #	Ball	I/O #	Ball	I/O #	Ball	I/O #	Ball	I/O #	Ball
164	A02	121	B16	108	E19	93	K19	11	T01	72	V20
160	A03	116	B17	105	E20	92	K20	13	T02	19	W03
158	A04	169	C01	176	F01	190	L01	14	T03	25	W05
154	A05	166	C02	175	F02	191	L02	74	T18	29	W06
151	A06	162	C04	173	F03	90	L18	75	T19	32	W07
149	A07	156	C06	107	F18	89	L19	21	U05	35	W08
146	A08	152	C07	104	F19	91	L20	28	U07	39	W09
142	A09	148	C08	102	F20	0*	M02	37	U09	41	W10
140	A10	144	C09	179	G01	1	M03	48	U12	45	W11
139	A11	138	C11	178	G02	2	M04	58	U14	46	W12
136	A12	134	C12	177	G03	85	M17	64	U16	50	W13
132	A13	130	C13	174	G04	86	M18	71	U18	53	W14
129	A14	127	C14	106	G17	87	M19	70	U19	56	W15
126	A15	123	C15	103	G18	88	M20	73	U20	60	W16
122	A16	120	C16	101	G19	3	N01	15	V01	66	W18
119*	A18	117	C17	100	G20	4	N02	16	V02	18	Y01
115	A19	111	C20	182	H01	5	N03	17	V03	22	Y03
114	A20	170	D01	181	H02	82	N18	20	V04	23	Y04
165	B01	167	D02	180	H03	83	N19	24	V05	26	Y05
163	B02	161	D05	99	H18	84	N20	27	V06	30	Y06
159	B04	155	D07	98	H19	6	P01	31	V07	33	Y07
157	B05	145	D09	97	H20	7	P02	34	V08	36	Y08
153	B06	133	D12	186	J01	9	P03	38	V09	40	Y09
150	B07	124	D14	185	J02	12	P04	42	V10	43	Y10
147	B08	118	D16	184	J03	77	P17	47	V12	44	Y11
143	B09	113	D18	183	J04	80	P18	51	V13	49	Y13
141	B10	109	D20	96	J17	81	P20	55	V14	52	Y14
137	B11	172	E01	189	K01	8	R01	59	V15	54	Y15
135	B12	171	E03	187	K02	10	R02	62	V16	57	Y16
131*	B13	168	E04	188	K03	76	R18	65	V17	61	Y17
128	B14	112	E17	95	K17	78	R19	68	V18	63	Y18
125	B15	110	E18	94	K18	79	R20	69	V19	67	Y19

\* I/O 119 is multiplexed with CLK2, I/O 131 is multiplexed with CLK3 and I/O 0 is multiplexed with TOE.

## 208-Pin PQFP Signal Locations

Signal	Pin
GOE0, GOE1	78, 79
TOE / I/O0	32
GSET/GRST	138
TCK	29
TDI	30
TDO	136
TMS	28
CLK0, CLK1	184,185
CLK2 / I/O89	162
CLK3 / I/O98	173
VCCIO	137
GND	3, 12, 19, 27, 39, 48, 58, 69, 77, 88, 99, 113, 121, 128, 135, 150, 164, 170, 179, 191, 199
VCC	7, 14, 22, 31, 41, 61, 80, 90, 110, 123, 139, 152, 156, 177, 186, 201
NC	49, 50, 51, 52, 101, 102, 103, 104, 105, 106, 107, 108, 109, 157, 158, 207, 208

1. NCs are not to be connected to any active signals, VCC or GND.

## 208-Pin PQFP I/O Locations

I/O #	Pin	I/O #	Pin	I/O #	Pin	I/O #	Pin	I/O #	Pin	I/O #	Pin
0*	32	24	65	48	96	72	140	96	171	120	203
1	33	25	66	49	97	73	141	97	172	121	204
2	34	26	67	50	98	74	142	98*	173	122	205
3	35	27	68	51	100	75	143	99	174	123	206
4	36	28	70	52	111	76	144	100	175	124	1
5	37	29	71	53	112	77	145	101	176	125	2
6	38	30	72	54	114	78	146	102	178	126	4
7	40	31	73	55	115	79	147	103	180	127	5
8	42	32	74	56	116	80	148	104	181	128	6
9	43	33	75	57	117	81	149	105	182	129	8
10	44	34	76	58	118	82	151	106	183	130	9
11	45	35	81	59	119	83	153	107	187	131	10
12	46	36	82	60	120	84	154	108	188	132	11
13	47	37	83	61	122	85	155	109	189	133	13
14	53	38	84	62	124	86	159	110	190	134	15
15	54	39	85	63	125	87	160	111	192	135	16
16	55	40	86	64	126	88	161	112	193	136	17
17	56	41	87	65	127	89*	162	113	194	137	18
18	57	42	89	66	129	90	163	114	195	138	20
19	59	43	91	67	130	91	165	115	196	139	21
20	60	44	92	68	131	92	166	116	197	140	23
21	62	45	93	69	132	93	167	117	198	141	24
22	63	46	94	70	133	94	168	118	200	142	25
23	64	47	95	71	134	95	169	119	202	143	26

\* I/O 89 is multiplexed with CLK2, I/O 98 is multiplexed with CLK3 and I/O 0 is multiplexed with TOE.

## 208-Ball fpBGA Signal Locations

Signal	Ball
GOE0, GOE1	P9, P10
TOE / I/O0	K1
GSET/GRST	H14
TCK	K2
TDI	K3
TDO	G14
TMS	J1
CLK0, CLK1	A7, B8
CLK2 / I/O89	B13
CLK3 / I/O98	A11
VCCIO	H15
GND	D5, D7, D8, D10, D12, D13, E4, F13, G4, G8, G9, H7, H10, H13, J4, J7, J10, J13, K8, K9, L4, L13, M13, N4, N5, N7, N8, N10, N12
VCC	D4, D6, D9, D11, E13, F4, G7, G10, G13, H4, H8, H9, J8, J9, K4, K7, K10, K13, M4, N6, N9, N11, N13
NC <sup>1</sup>	C14, E15

1. NCs are not to be connected to any active signals, VCC or GND.

## 208-Ball fpBGA I/O Locations (Sorted by I/O)

I/O #	Ball	I/O #	Ball	I/O #	Ball	I/O #	Ball	I/O #	Ball	I/O #	Ball
0*	K1	24	T4	48	R12	72	G16	96	C11	120	C3
1	L2	25	T5	49	P14	73	F14	97	B11	121	C2
2	L1	26	R7	50	P13	74	G15	98*	A11	122	B3
3	L3	27	P6	51	R13	75	F16	99	B10	123	B2
4	M1	28	T6	52	R15	76	E14	100	A10	124	A1
5	M2	29	T7	53	P15	77	F15	101	C10	125	D2
6	M3	30	R8	54	R16	78	E16	102	B9	126	B1
7	N1	31	P8	55	P16	79	D16	103	C9	127	D3
8	N3	32	P7	56	N15	80	C16	104	A9	128	E2
9	N2	33	T8	57	N14	81	B16	105	A8	129	C1
10	P2	34	T9	58	M14	82	D15	106	C8	130	E3
11	P1	35	R9	59	N16	83	D14	107	C7	131	D1
12	R1	36	R10	60	M15	84	A16	108	B7	132	F2
13	R2	37	T10	61	M16	85	C15	109	A6	133	E1
14	R3	38	T11	62	L14	86	B15	110	A5	134	F1
15	P3	39	T12	63	L15	87	A15	111	C6	135	G2
16	T1	40	T13	64	L16	88	B14	112	B6	136	F3
17	P4	41	T14	65	K14	89*	B13	113	A4	137	H2
18	R4	42	P11	66	K15	90	C13	114	A3	138	H3
19	R5	43	P12	67	K16	91	A14	115	A2	139	G3
20	P5	44	R11	68	J14	92	C12	116	C5	140	G1
21	T2	45	T15	69	J15	93	B12	117	B5	141	H1
22	R6	46	T16	70	J16	94	A13	118	B4	142	J2
23	T3	47	R14	71	H16	95	A12	119	C4	143	J3

\* I/O 89 is multiplexed with CLK2, I/O 98 is multiplexed with CLK3 and I/O 0 is multiplexed with TOE.

**208-Ball fpBGA I/O Locations (Sorted by Ball)**

I/O #	Ball	I/O #	Ball	I/O #	Ball	I/O #	Ball	I/O #	Ball	I/O #	Ball
124	A01	97	B11	83	D14	143	J03	56	N15	35	R09
115	A02	93	B12	82	D15	68	J14	59	N16	36	R10
114	A03	89*	B13	79	D16	69	J15	11	P01	44	R11
113	A04	88	B14	133	E01	70	J16	10	P02	48	R12
110	A05	86	B15	128	E02	0*	K01	15	P03	51	R13
109	A06	81	B16	130	E03	65	K14	17	P04	47	R14
105	A08	129	C01	76	E14	66	K15	20	P05	52	R15
104	A09	121	C02	78	E16	67	K16	27	P06	54	R16
100	A10	120	C03	134	F01	2	L01	32	P07	16	T01
98*	A11	119	C04	132	F02	1	L02	31	P08	21	T02
95	A12	116	C05	136	F03	3	L03	42	P11	23	T03
94	A13	111	C06	73	F14	62	L14	43	P12	24	T04
91	A14	107	C07	77	F15	63	L15	50	P13	25	T05
87	A15	106	C08	75	F16	64	L16	49	P14	28	T06
84	A16	103	C09	140	G01	4	M01	53	P15	29	T07
126	B01	101	C10	135	G02	5	M02	55	P16	33	T08
123	B02	96	C11	139	G03	6	M03	12	R01	34	T09
122	B03	92	C12	74	G15	58	M14	13	R02	37	T10
118	B04	90	C13	72	G16	60	M15	14	R03	38	T11
117	B05	85	C15	141	H01	61	M16	18	R04	39	T12
112	B06	80	C16	137	H02	7	N01	19	R05	40	T13
108	B07	131	D01	138	H03	9	N02	22	R06	41	T14
102	B09	125	D02	71	H16	8	N03	26	R07	45	T15
99	B10	127	D03	142	J02	57	N14	30	R08	46	T16

\* I/O 89 is multiplexed with CLK2, I/O 98 is multiplexed with CLK3 and I/O 0 is multiplexed with TOE.

**Signal Configuration**

**ispLSI 5256VA 272-ball BGA**

	20	19	18	17	16	15	14	13	12	11	10	9	8	7	6	5	4	3	2	1																
A	I/O 114	I/O 115	CLK2/ I/O 119	NC <sup>1</sup>	I/O 122	I/O 126	I/O 129	I/O 132	I/O 136	I/O 139	I/O 140	I/O 142	I/O 146	I/O 149	I/O 151	I/O 154	I/O 158	I/O 160	I/O 164	GND																
B	NC <sup>1</sup>	NC <sup>1</sup>	NC <sup>1</sup>	I/O 116	I/O 121	I/O 125	I/O 128	CLK3/ I/O 131	I/O 135	I/O 137	I/O 141	I/O 143	I/O 147	I/O 150	I/O 153	I/O 157	I/O 159	NC <sup>1</sup>	I/O 163	I/O 165																
C	I/O 111	NC <sup>1</sup>	NC <sup>1</sup>	I/O 117	I/O 120	I/O 123	I/O 127	I/O 130	I/O 134	I/O 138	CLK0	I/O 144	I/O 148	I/O 152	I/O 156	NC <sup>1</sup>	I/O 162	NC <sup>1</sup>	I/O 166	I/O 169																
D	I/O 109	NC <sup>1</sup>	I/O 113	GND	I/O 118	VCC	I/O 124	GND	I/O 133	VCC	CLK1	I/O 145	GND	I/O 155	VCC	I/O 161	GND	NC <sup>1</sup>	I/O 167	I/O 170																
E	I/O 105	I/O 108	I/O 110	I/O 112	<b>ispLSI 5256VA</b> Bottom View <table border="1" style="margin: 20px auto;"> <tr><td>GND</td><td>GND</td><td>GND</td><td>GND</td></tr> <tr><td>GND</td><td>GND</td><td>GND</td><td>GND</td></tr> <tr><td>GND</td><td>GND</td><td>GND</td><td>GND</td></tr> <tr><td>GND</td><td>GND</td><td>GND</td><td>GND</td></tr> </table>												GND	GND	GND	GND	GND	GND	GND	GND	GND	GND	GND	GND	GND	GND	GND	GND	I/O 168	I/O 171	NC <sup>1</sup>	I/O 172
GND	GND	GND	GND																																	
GND	GND	GND	GND																																	
GND	GND	GND	GND																																	
GND	GND	GND	GND																																	
F	I/O 102	I/O 104	I/O 107	VCC													I/O 174	I/O 177	I/O 178	I/O 179																
G	I/O 100	I/O 101	I/O 103	I/O 106													GND	I/O 180	I/O 181	I/O 182																
H	I/O 97	I/O 98	I/O 99	GND													I/O 183	I/O 184	I/O 185	I/O 186																
J	TDO	vccio	SET/ RST	I/O 96													VCC	I/O 188	I/O 187	I/O 189																
K	I/O 92	I/O 93	I/O 94	I/O 95													TCK	TMS	I/O 191	I/O 190																
L	I/O 91	I/O 89	I/O 90	VCC	I/O 2	I/O 1	TOE I/O 0	TDI																												
M	I/O 88	I/O 87	I/O 86	I/O 85	GND	I/O 5	I/O 4	I/O 3																												
N	I/O 84	I/O 83	I/O 82	GND	I/O 12	I/O 9	I/O 7	I/O 6																												
P	I/O 81	NC <sup>1</sup>	I/O 80	I/O 77	VCC	NC <sup>1</sup>	I/O 10	I/O 8																												
R	I/O 79	I/O 78	I/O 76	VCC	NC <sup>1</sup>	I/O 14	I/O 13	I/O 11																												
T	NC <sup>1</sup>	I/O 75	I/O 74	NC <sup>1</sup>	I/O 73	I/O 70	I/O 71	GND	I/O 64	VCC	I/O 58	GND	I/O 48	GOE1	VCC	I/O 37	GND	I/O 28	VCC	I/O 21	GND	NC <sup>1</sup>	NC <sup>1</sup>	NC <sup>1</sup>												
U	I/O 72	I/O 69	I/O 68	I/O 65	I/O 62	I/O 59	I/O 55	I/O 51	I/O 47	GOE0	I/O 42	I/O 38	I/O 34	I/O 31	I/O 27	I/O 24	I/O 20	I/O 17	I/O 16	I/O 15																
V	NC <sup>1</sup>	NC <sup>1</sup>	I/O 66	NC <sup>1</sup>	I/O 60	I/O 56	I/O 53	I/O 50	I/O 46	I/O 45	I/O 41	I/O 39	I/O 35	I/O 32	I/O 29	I/O 25	NC <sup>1</sup>	I/O 19	NC <sup>1</sup>	NC <sup>1</sup>																
W	NC <sup>1</sup>	I/O 67	I/O 63	I/O 61	I/O 57	I/O 54	I/O 52	I/O 49	NC <sup>1</sup>	I/O 44	I/O 43	I/O 40	I/O 36	I/O 33	I/O 30	I/O 26	I/O 23	I/O 22	NC <sup>1</sup>	I/O 18																
Y																																				

1. NCs are not to be connected to any active signals, Vcc or GND.

272 BGA/5256VA

Note: Ball A1 indicator dot on top side of package.



**Pin Configuration**

**ispLSI 5256VA 208-pin PQFP**

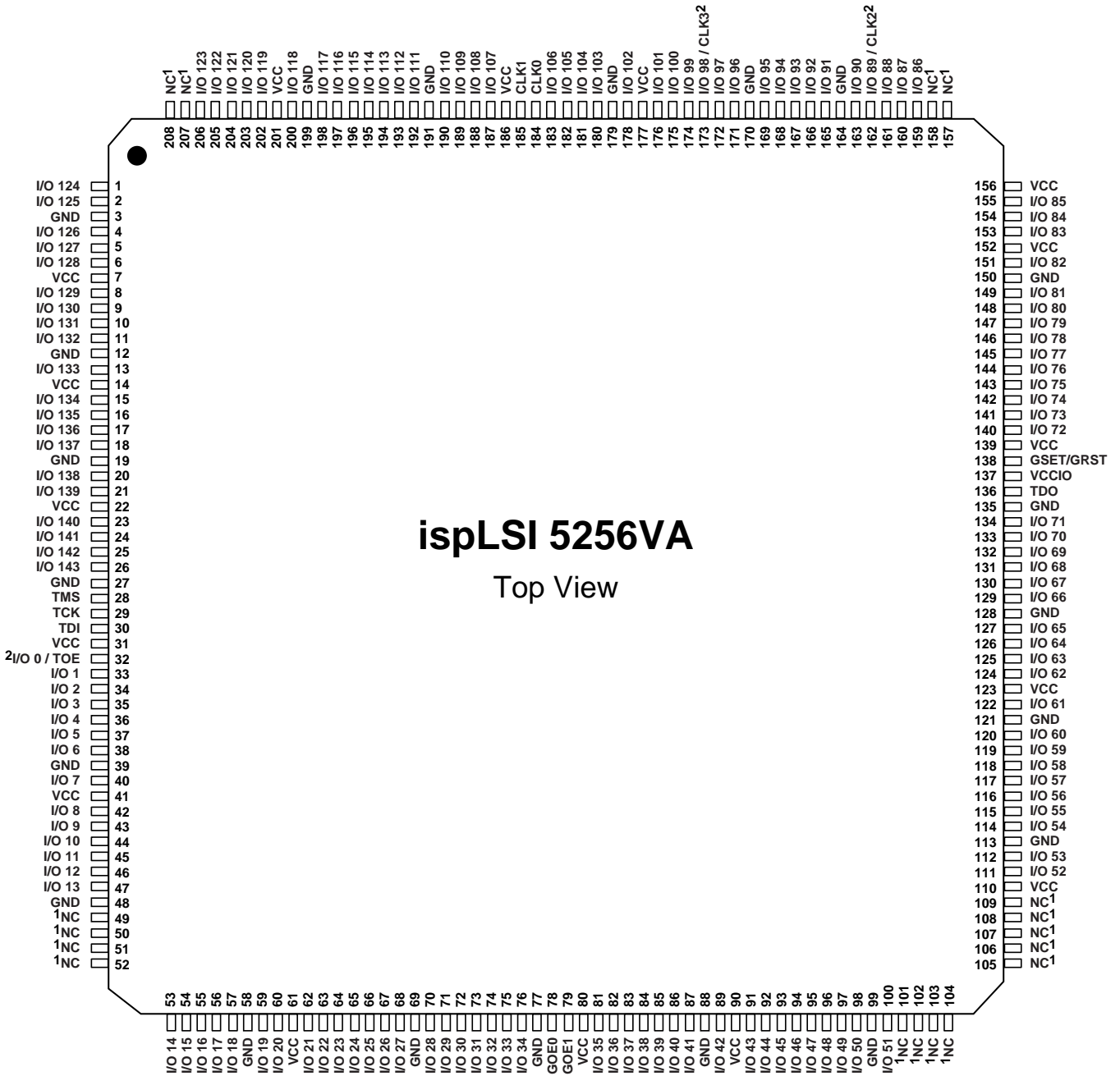

208-PQFP/5256VA

1. NC pins are not to be connected to any active signal, Vcc or GND.
2. Pins have dual function capability.

**Signal Configuration**

**ispLSI 5256VA 208-ball fpBGA**

	16	15	14	13	12	11	10	9	8	7	6	5	4	3	2	1																	
<b>A</b>	I/O 84	I/O 87	I/O 91	I/O 94	I/O 95	CLK3/ I/O98	I/O 100	I/O 104	I/O 105	CLK 0	I/O 109	I/O 110	I/O 113	I/O 114	I/O 115	I/O 124	<b>A</b>																
<b>B</b>	I/O 81	I/O 86	I/O 88	CLK2/ I/O89	I/O 93	I/O 97	I/O 99	I/O 102	CLK 1	I/O 108	I/O 112	I/O 117	I/O 118	I/O 122	I/O 123	I/O 126	<b>B</b>																
<b>C</b>	I/O 80	I/O 85	NC <sup>1</sup>	I/O 90	I/O 92	I/O 96	I/O 101	I/O 103	I/O 106	I/O 107	I/O 111	I/O 116	I/O 119	I/O 120	I/O 121	I/O 129	<b>C</b>																
<b>D</b>	I/O 79	I/O 82	I/O 83	GND	GND	VCC	GND	VCC	GND	GND	VCC	GND	VCC	I/O 127	I/O 125	I/O 131	<b>D</b>																
<b>E</b>	I/O 78	NC <sup>1</sup>	I/O 76	VCC	<div style="border: 1px solid black; padding: 10px; display: inline-block;"> <p><b>ispLSI 5256VA</b> Bottom View</p> <table border="1" style="margin: auto;"> <tr> <td>VCC</td> <td>GND</td> <td>GND</td> <td>VCC</td> </tr> <tr> <td>GND</td> <td>VCC</td> <td>VCC</td> <td>GND</td> </tr> <tr> <td>GND</td> <td>VCC</td> <td>VCC</td> <td>GND</td> </tr> <tr> <td>VCC</td> <td>GND</td> <td>GND</td> <td>VCC</td> </tr> </table> </div>								VCC	GND	GND	VCC	GND	VCC	VCC	GND	GND	VCC	VCC	GND	VCC	GND	GND	VCC	GND	I/O 130	I/O 128	I/O 133	<b>E</b>
VCC	GND	GND	VCC																														
GND	VCC	VCC	GND																														
GND	VCC	VCC	GND																														
VCC	GND	GND	VCC																														
<b>F</b>	I/O 75	I/O 77	I/O 73	GND	VCC	I/O 136	I/O 132	I/O 134	<b>F</b>																								
<b>G</b>	I/O 72	I/O 74	TDO	VCC	GND	I/O 139	I/O 135	I/O 140	<b>G</b>																								
<b>H</b>	I/O 71	VCCIO	GSET/ GRST	GND	GND	I/O 138	I/O 137	I/O 141	<b>H</b>																								
<b>J</b>	I/O 70	I/O 69	I/O 68	GND	GND	I/O 143	I/O 142	TMS	<b>J</b>																								
<b>K</b>	I/O 67	I/O 66	I/O 65	VCC	VCC	I/O 143	TDI	TCK	TOE/ I/O0	<b>K</b>																							
<b>L</b>	I/O 64	I/O 63	I/O 62	GND	GND	I/O 3	I/O 1	I/O 2	<b>L</b>																								
<b>M</b>	I/O 61	I/O 60	I/O 58	GND	VCC	I/O 6	I/O 5	I/O 4	<b>M</b>																								
<b>N</b>	I/O 59	I/O 56	I/O 57	VCC	GND	VCC	GND	VCC	GND	GND	VCC	GND	GND	I/O 8	I/O 9	I/O 7	<b>N</b>																
<b>P</b>	I/O 55	I/O 53	I/O 49	I/O 50	I/O 43	I/O 42	GOE1	GOE0	I/O 31	I/O 32	I/O 27	I/O 20	I/O 17	I/O 15	I/O 10	I/O 11	<b>P</b>																
<b>R</b>	I/O 54	I/O 52	I/O 47	I/O 51	I/O 48	I/O 44	I/O 36	I/O 35	I/O 30	I/O 26	I/O 22	I/O 19	I/O 18	I/O 14	I/O 13	I/O 12	<b>R</b>																
<b>T</b>	I/O 46	I/O 45	I/O 41	I/O 40	I/O 39	I/O 38	I/O 37	I/O 34	I/O 33	I/O 29	I/O 28	I/O 25	I/O 24	I/O 23	I/O 21	I/O 16	<b>T</b>																
	16	15	14	13	12	11	10	9	8	7	6	5	4	3	2	1																	

208 fpBGA/5256VA

1. NCs are not to be connected to any active signals, Vcc or GND.

Note: Ball A1 indicator dot on top side of package.

## Part Number Description

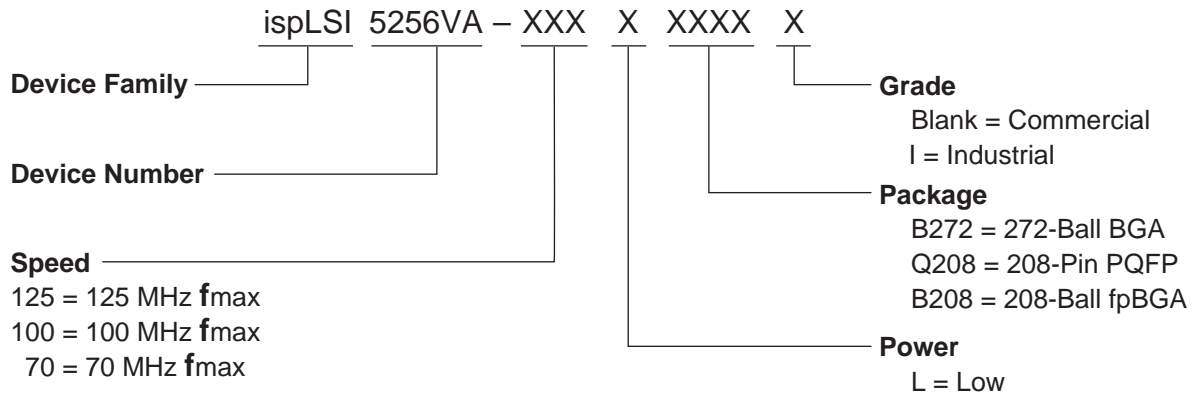

0212/5256VA

## Ordering Information

### COMMERCIAL

FAMILY	<i>f</i> <sub>max</sub> (MHz)	<i>t</i> <sub>pd</sub> (ns)	ORDERING NUMBER	PACKAGE
ispLSI	125	7.5	ispLSI 5256VA-125LB272	272-Ball BGA
	125	7.5	ispLSI 5256VA-125LQ208	208-Pin PQFP
	125	7.5	ispLSI 5256VA-125LB208	208-Ball fpBGA
	100	10	ispLSI 5256VA-100LB272	272-Ball BGA
	100	10	ispLSI 5256VA-100LQ208	208-Pin PQFP
	100	10	ispLSI 5256VA-100LB208	208-Ball fpBGA
	70	15	ispLSI 5256VA-70LB272	272-Ball BGA
	70	15	ispLSI 5256VA-70LQ208	208-Pin PQFP
	70	15	ispLSI 5256VA-70LB208	208-Ball fpBGA

Table 2-0041A/5256VA

### INDUSTRIAL

FAMILY	<i>f</i> <sub>max</sub> (MHz)	<i>t</i> <sub>pd</sub> (ns)	ORDERING NUMBER	PACKAGE
ispLSI	70	15	ispLSI 5256VA-70LB272I	272-Ball BGA

Table 2-0041B/5256VA