

---

---

## 2.4 GHz High-Linearity, High-Efficiency Power Amplifier

---

---

### Features

- High Gain:
  - Typically 37 dB gain across 2.4–2.5 GHz over temperature -20°C to +85°C
- High linear output power:
  - >30 dBm P1dB
    - Please refer to [“Absolute Maximum Stress Ratings” on page 5](#)
  - Meets 802.11g OFDM spectrum mask requirement up to 28 dBm
  - Typically 25 dBm with <3% EVM, 802.11g, 54 Mbps
  - Typically 24 dBm with <2.5% EVM, 802.11n, MCS7-HT20, 50% duty cycle
  - Typically 24 dBm with <1.75% EVM, MCS9-HT40, 50% duty cycle
  - Meets 802.11b ACPR requirement up to 28 dBm
- High-speed power-up/down
  - Turn on/off time (10%-90%) <100 ns
- 10:1 VSWR survivability (unconditionally stable up to 28 dBm)
- On-chip power detection
  - >20 dB dynamic range
  - VSWR- and temperature-insensitive
- Simple input/output matching
- Packages available
  - 16-contact UQFN (3mm x 3mm)
    - Pin-to-pin compatible with SST12CP11
- All non-Pb (lead-free) devices are RoHS compliant

### Applications

- WLAN (IEEE 802.11b/g/n)
- WLAN 256 QAM
- AP router
- WiMax (IEEE 802.16e)
- Home RF
- Cordless phones
- 2.4 GHz ISM wireless equipment

### 1.0 PRODUCT DESCRIPTION

SST12CP11C is a high-power and high-gain power amplifier (PA) based on the highly-reliable InGaP/GaAs HBT technology.

This PA can be easily configured for high-power applications with high power-added efficiency while operating over the 2.4-2.5 GHz frequency band. It typically provides 37 dB gain with 25% power-added efficiency @  $P_{OUT} = 28$  dBm for 802.11g.

SST12CP11C has excellent linearity, typically 25 dBm at 3% EVM with 54 Mbps 802.11g operation while meeting 802.11g spectrum mask at 28 dBm. SST12CP11C also has a single-ended power detector which lowers the users' cost for power control.

The power amplifier IC also features easy board-level usage along with high-speed power-up/-down control.

SST12CP11C is offered in 16-contact UQFN package. See [Figure 3-1](#) for pin assignments and [Table 4-1](#) for pin descriptions.

## TO OUR VALUED CUSTOMERS

It is our intention to provide our valued customers with the best documentation possible to ensure successful use of your Microchip products. To this end, we will continue to improve our publications to better suit your needs. Our publications will be refined and enhanced as new volumes and updates are introduced.

If you have any questions or comments regarding this publication, please contact the Marketing Communications Department via E-mail at [docerrors@microchip.com](mailto:docerrors@microchip.com). We welcome your feedback.

### Most Current Data Sheet

To obtain the most up-to-date version of this data sheet, please register at our Worldwide Web site at:

<http://www.microchip.com>

You can determine the version of a data sheet by examining its literature number found on the bottom outside corner of any page. The last character of the literature number is the version number, (e.g., DS30000000A is version A of document DS30000000).

### Errata

An errata sheet, describing minor operational differences from the data sheet and recommended workarounds, may exist for current devices. As device/documentation issues become known to us, we will publish an errata sheet. The errata will specify the revision of silicon and revision of document to which it applies.

To determine if an errata sheet exists for a particular device, please check with one of the following:

- Microchip's Worldwide Web site; <http://www.microchip.com>
- Your local Microchip sales office (see last page)

When contacting a sales office, please specify which device, revision of silicon and data sheet (include literature number) you are using.

### Customer Notification System

Register on our web site at [www.microchip.com](http://www.microchip.com) to receive the most current information on all of our products.

2.0 FUNCTIONAL BLOCKS

FIGURE 2-1: FUNCTIONAL BLOCK DIAGRAM

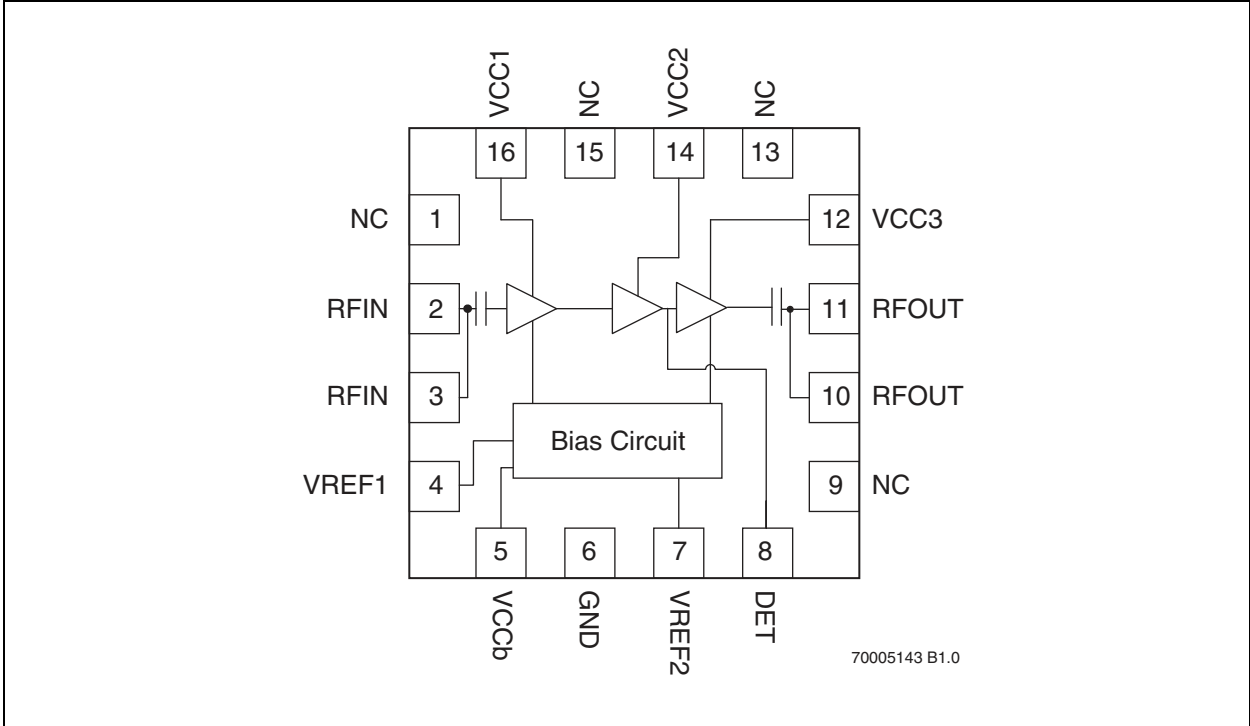

## 3.0 PIN ASSIGNMENTS

FIGURE 3-1: PIN ASSIGNMENTS FOR 16-CONTACT UQFN

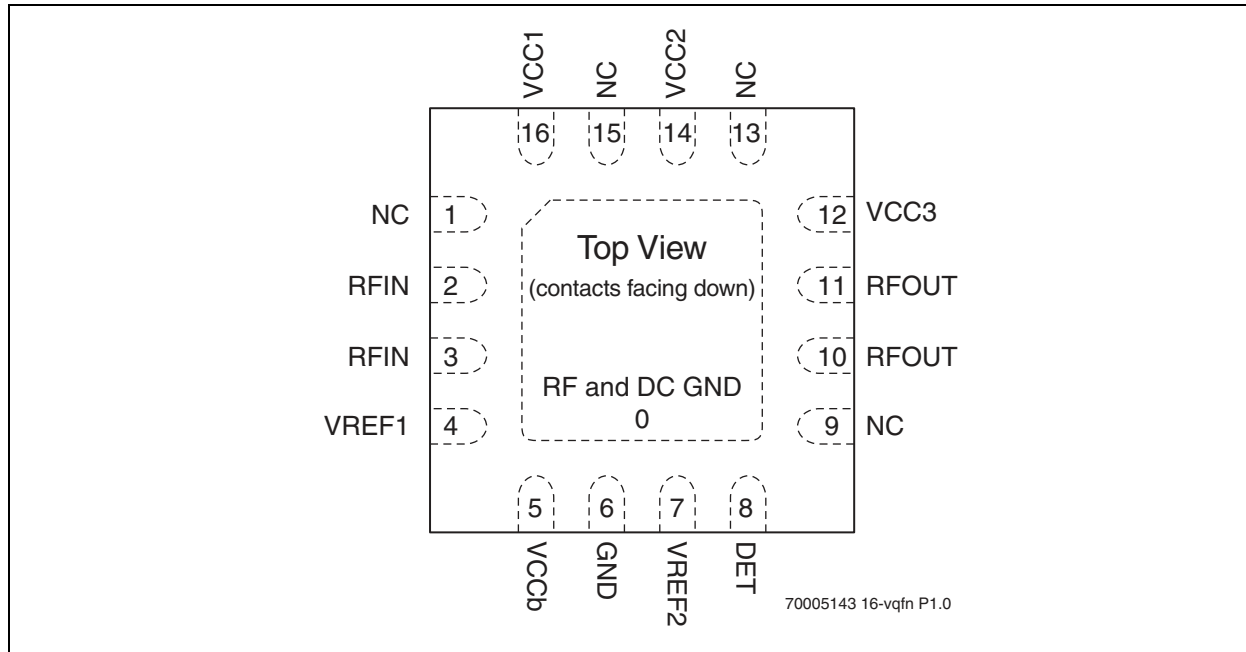

## 4.0 PIN DESCRIPTIONS

TABLE 4-1: PIN DESCRIPTION

Symbol	Pin No.	Pin Name	Type <sup>1</sup>	Function
GND	0	Ground		The center pad should be connected to RF ground with several low inductance, low resistance vias.
NC	1	No Connection		Unconnected pins.
RFIN	2		I	RF input, DC decoupled
RFIN	3		I	RF input, DC decoupled
VREF1	4	Power Supply	PWR	1 <sup>st</sup> stage, idle-current control
VCCb	5	Power Supply	PWR	Supply voltage for bias circuit
GND	6	Ground		
VREF2	7	Power supply	PWR	2 <sup>nd</sup> and 3 <sup>rd</sup> stage, idle-current control
DET	8		O	On-chip power detector
NC	9	No Connection		Unconnected pins.
RFOUT	10		O	RF output
RFOUT	11		O	RF output
VCC3	12	Power Supply	PWR	Power supply, 3rd stage
NC	13	No Connection		Unconnected pins.
VCC2	14	Power Supply	PWR	Power supply, 2nd stage
NC	15	No Connection		Unconnected pins.
VCC1	16	Power Supply	PWR	Power supply, 1st stage

1. I=Input, O=Output

## 5.0 ELECTRICAL SPECIFICATIONS

The DC and RF specifications for the power amplifier are specified below. Refer to [Table 5-2](#) for the DC voltage and current specifications.

**Absolute Maximum Stress Ratings** (Applied conditions greater than those listed under “Absolute Maximum Stress Ratings” may cause permanent damage to the device. This is a stress rating only and functional operation of the device at these conditions or conditions greater than those defined in the operational sections of this data sheet is not implied. Exposure to absolute maximum stress rating conditions may affect device reliability.)

Input power to pin 2 and 3 ( $P_{IN}$ )	-3 dBm
Supply voltage at pins 5,12,14 and 16 ( $V_{CC}$ )	+6 V
Reference voltage to pin 4 ( $V_{REF1}$ ) and pin 7 ( $V_{REF2}$ )	+3.2 V
DC supply current ( $I_{CC}$ )	650 mA
Operating Temperature ( $T_A$ )	-40°C to +85°C
Storage Temperature ( $T_{STG}$ )	-40°C to +120°C
Maximum Junction Temperature ( $T_J$ )	+150°C
Surface Mount Solder Reflow Temperature	260°C for 10 seconds

**TABLE 5-1: OPERATING RANGE**

Range	Ambient Temp	$V_{CC}$
Industrial	-20°C to +85°C	3.3 to 5.0V

**TABLE 5-2: DC ELECTRICAL CHARACTERISTICS AT 25°C**

Symbol	Parameter	Min.	Typ	Max.	Unit
$V_{CC}$	Supply Voltage	3.3	5.0	5.5	V
$I_{CC}$	DC Current				
	for 802.11g, 28 dBm		500		mA
	for 802.11b, 28 dBm		500		mA
$I_{CQ}$	Idle Current for 802.11g to meet EVM<3% @24.5 dBm, $V_{CC} = 5.0V$		280		mA
	Idle Current, $V_{CC} = 3.3V$		205		mA
$V_{REG}$	Reference Voltage see <a href="#">Figure 6-8 on page 10</a>	2.9	2.95	3.1	V
$I_{REG}$	Reference Current		8		mA

**TABLE 5-3: AC ELECTRICAL CHARACTERISTICS FOR CONFIGURATION AT  $V_{CC} = 5V$ ,  $V_{REF} = 2.95V$ , 25°C, 50% DUTY CYCLE**

Symbol	Parameter	Min.	Typ	Max.	Unit
$F_{L-U}$	Frequency range in 802.11b/g applications	2400		2500	MHz
$P_{OUT}$	Output power at 3% EVM with 802.11g OFDM at 54 Mbps		25		dBm
	Output power at 2.5% EVM with 802.11n MCS7 HT20		24		dBm
	Output power at 1.75% EVM with 256 QAM MCS9 HT40		23.5		dBm
	Output power meeting 802.11g spectral mask		28		dBm
	Output power meeting 802.11n HT20 spectral mask		26		dBm
	Output power meeting MCS9-HT40 spectral mask		26		dBm
	Output power meeting 802.11b spectral mask		28		dBm
	Output power at 3% EVM with 802.11g, $V_{CC} = 3.3V$		20.5		dBm
G	Power gain for 802.11b/g/n/256 QAM	35	37		dB
	Power gain for 802.11b/g/n/256 QAM, $V_{CC} = 3.3V$		38		dB
$G_{VAR}$	Gain variation over band			±0.5	dB
2f	Second Harmonic at 28 dBm, 802.11b mask compliance		-15		dBm/MHz
	Second Harmonic at 26 dBm		-30		dBm/MHz
3f	Third Harmonic at 28 dBm, 802.11b mask compliance		-20		dBm/MHz
	Third Harmonic at 26 dBm		-50		dBm/MHz

## 6.0 TYPICAL PERFORMANCE CHARACTERISTICS

Test Conditions:  $V_{CC} = 5.0V$ ,  $V_{REG} = 2.95V$ ,  $T_A = 25^\circ C$ , unless otherwise specified

FIGURE 6-1: S-PARAMETERS

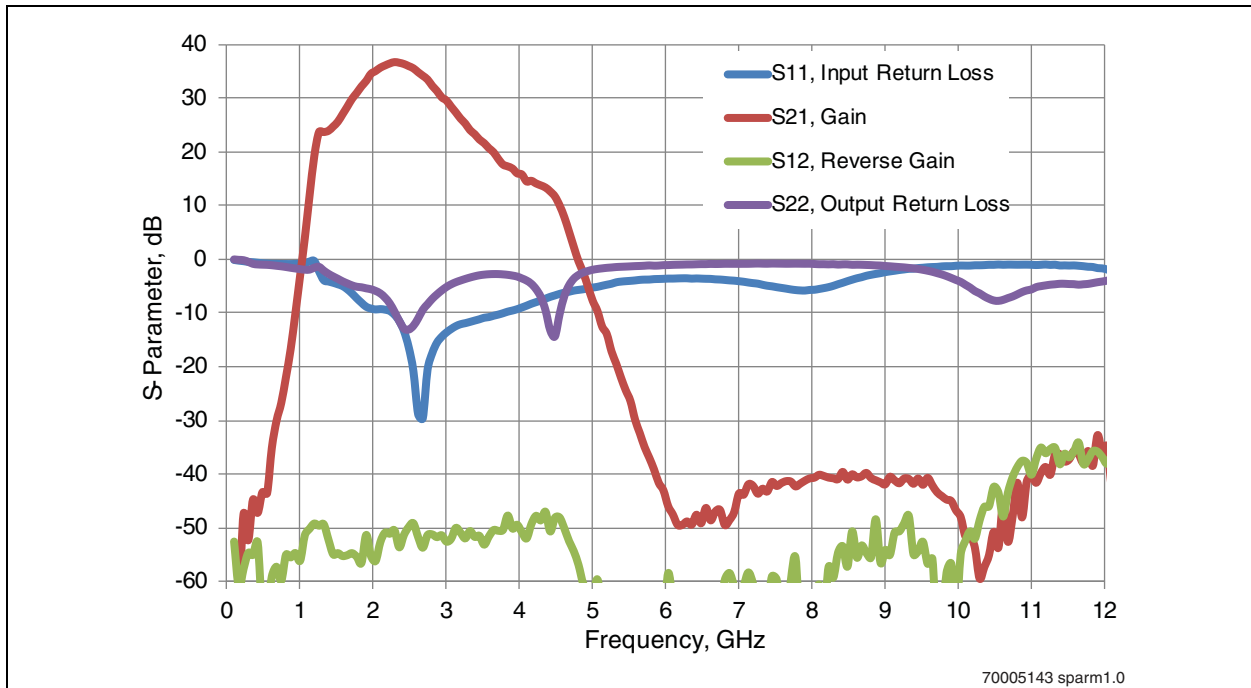

Test Conditions:  $V_{CC} = 5.0V$ ,  $V_{REG} = 2.95V$ ,  $T_A = 25^\circ C$ , IEEE 802.11g, 54 Mbps, 50% duty cycle unless otherwise specified

FIGURE 6-2: DYNAMIC EVM VERSUS OUTPUT POWER

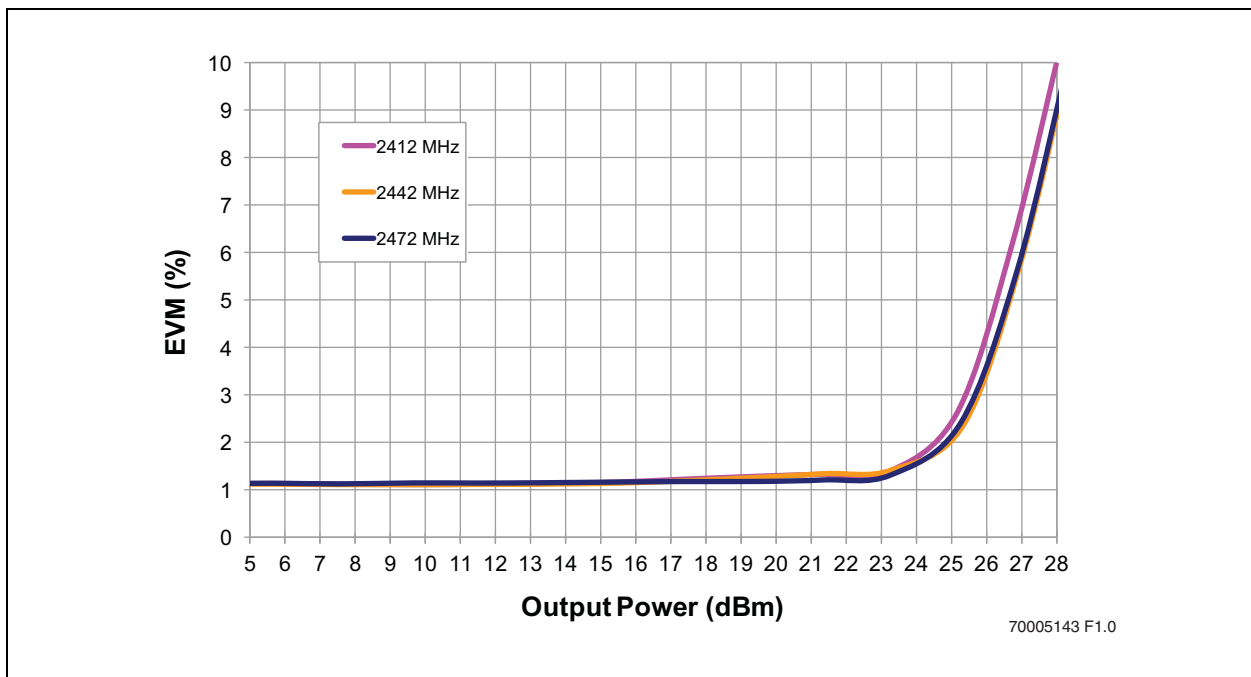

FIGURE 6-3: DYNAMIC EVM VERSUS OUTPUT POWER, WITH MCS7-20 MHz

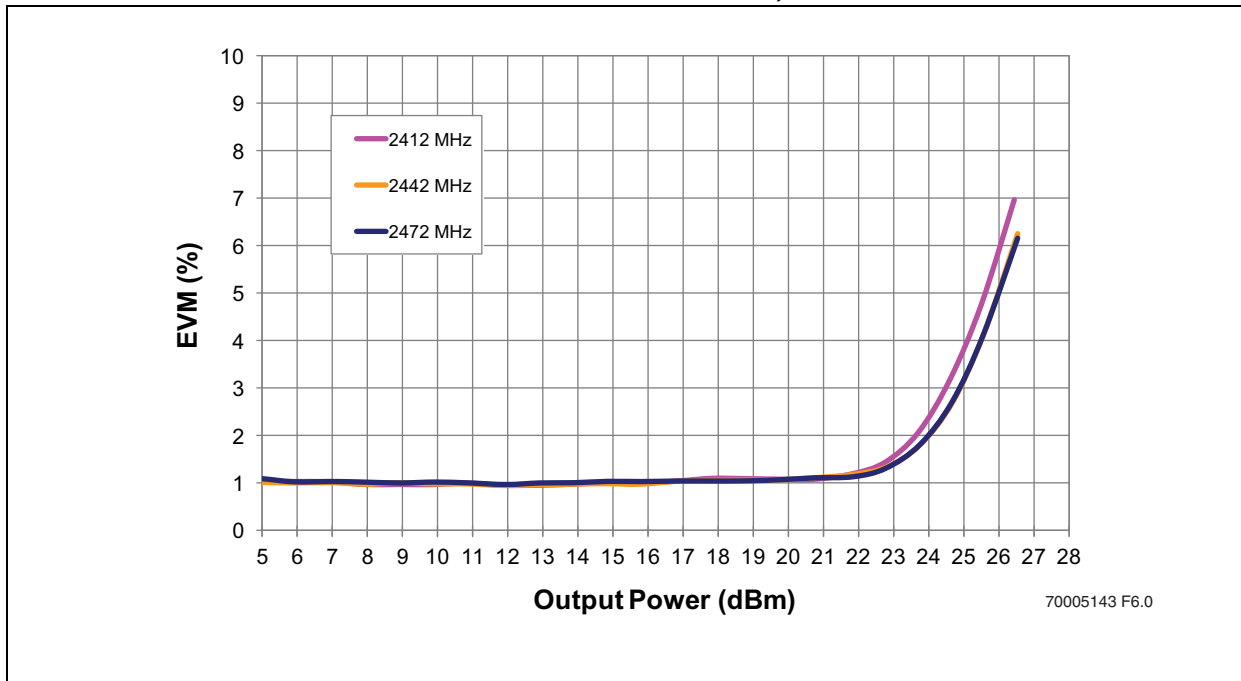

FIGURE 6-4: DYNAMIC EVM VERSUS OUTPUT POWER, WITH MCS9-40 MHz, 50% DUTY CYCLE

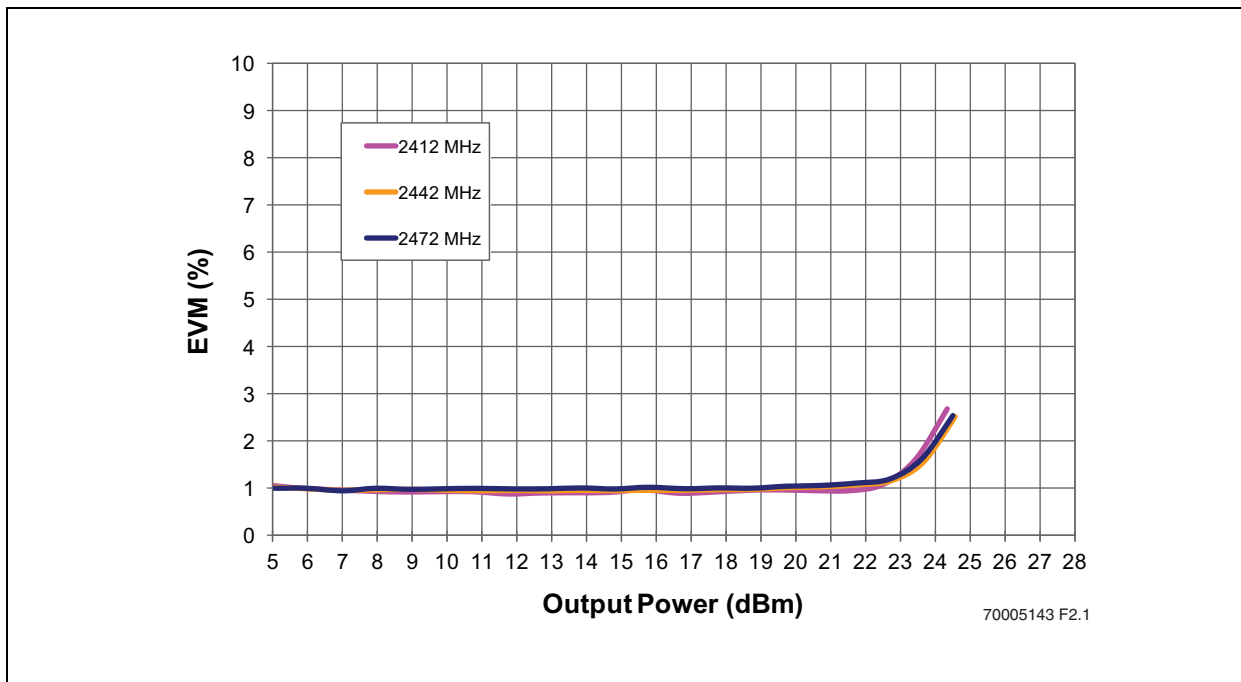



FIGURE 6-5: POWER GAIN VERSUS OUTPUT POWER

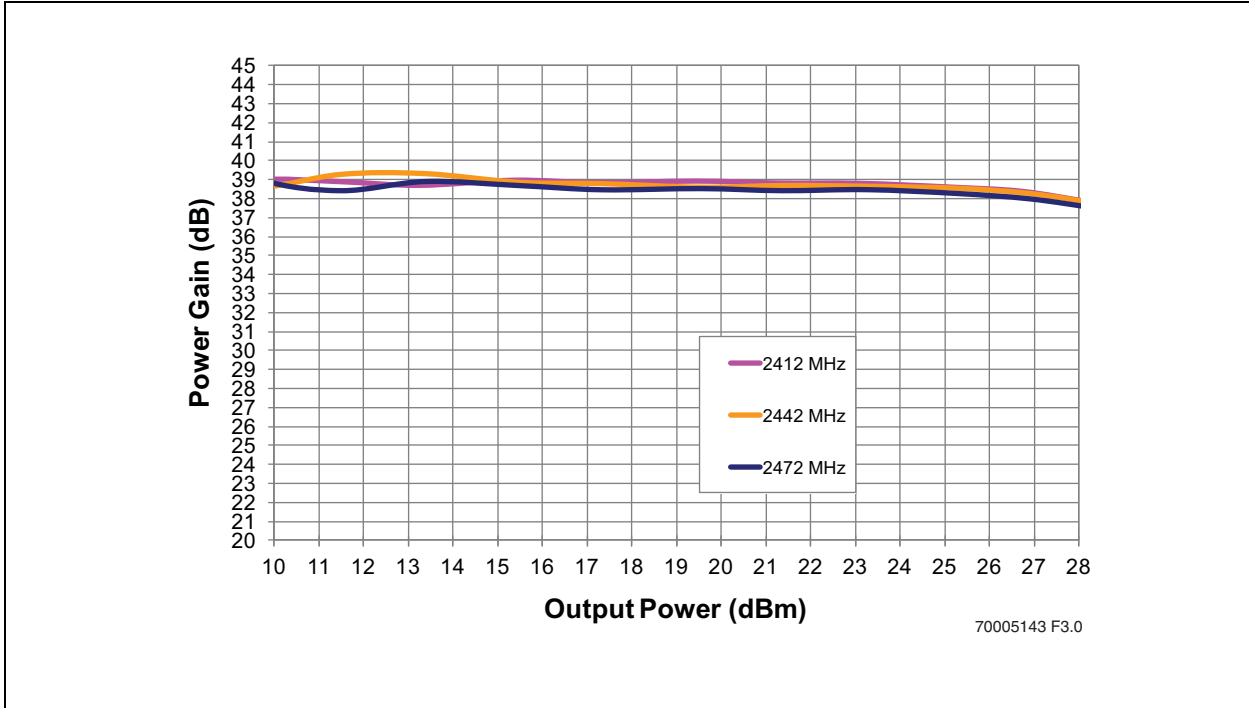

FIGURE 6-6: SUPPLY CURRENT VERSUS OUTPUT POWER

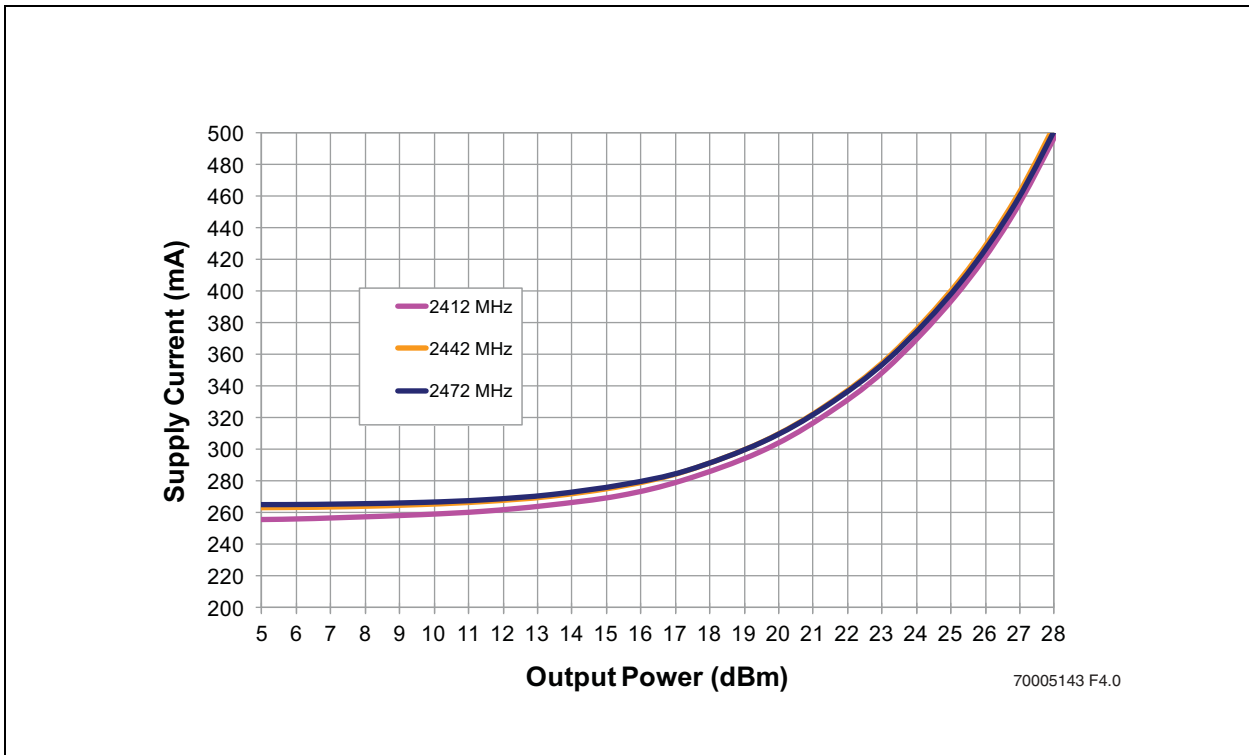

FIGURE 6-7: DETECTOR CHARACTERISTIC VERSUS OUTPUT POWER

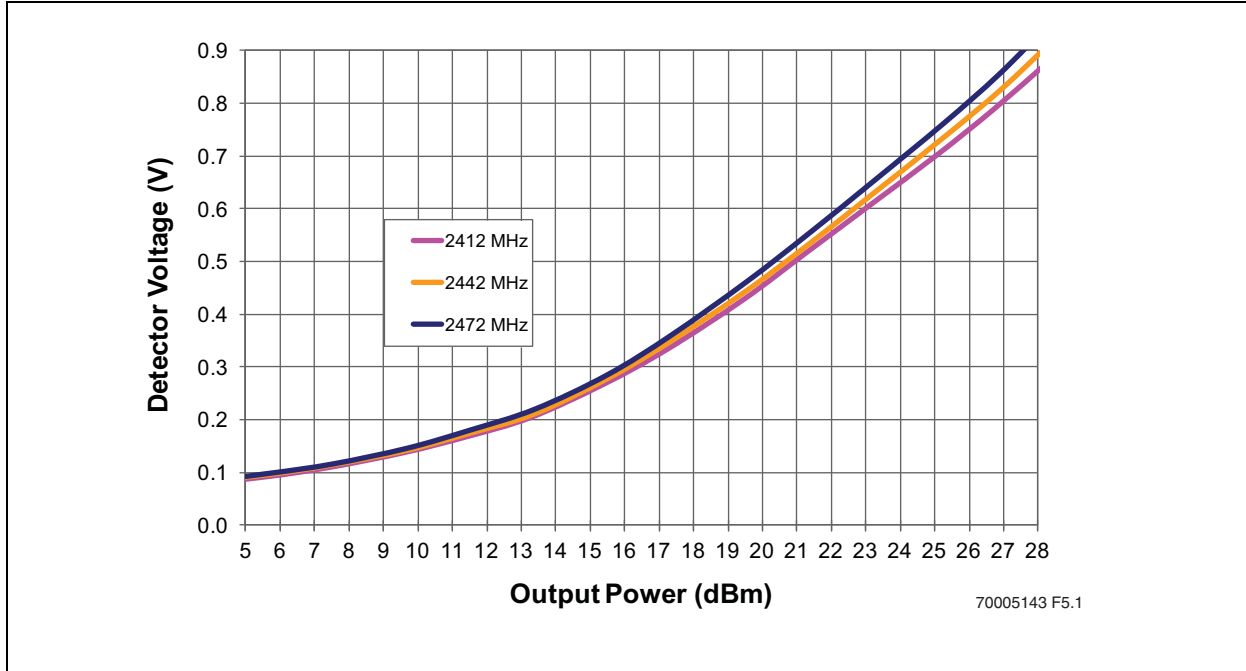
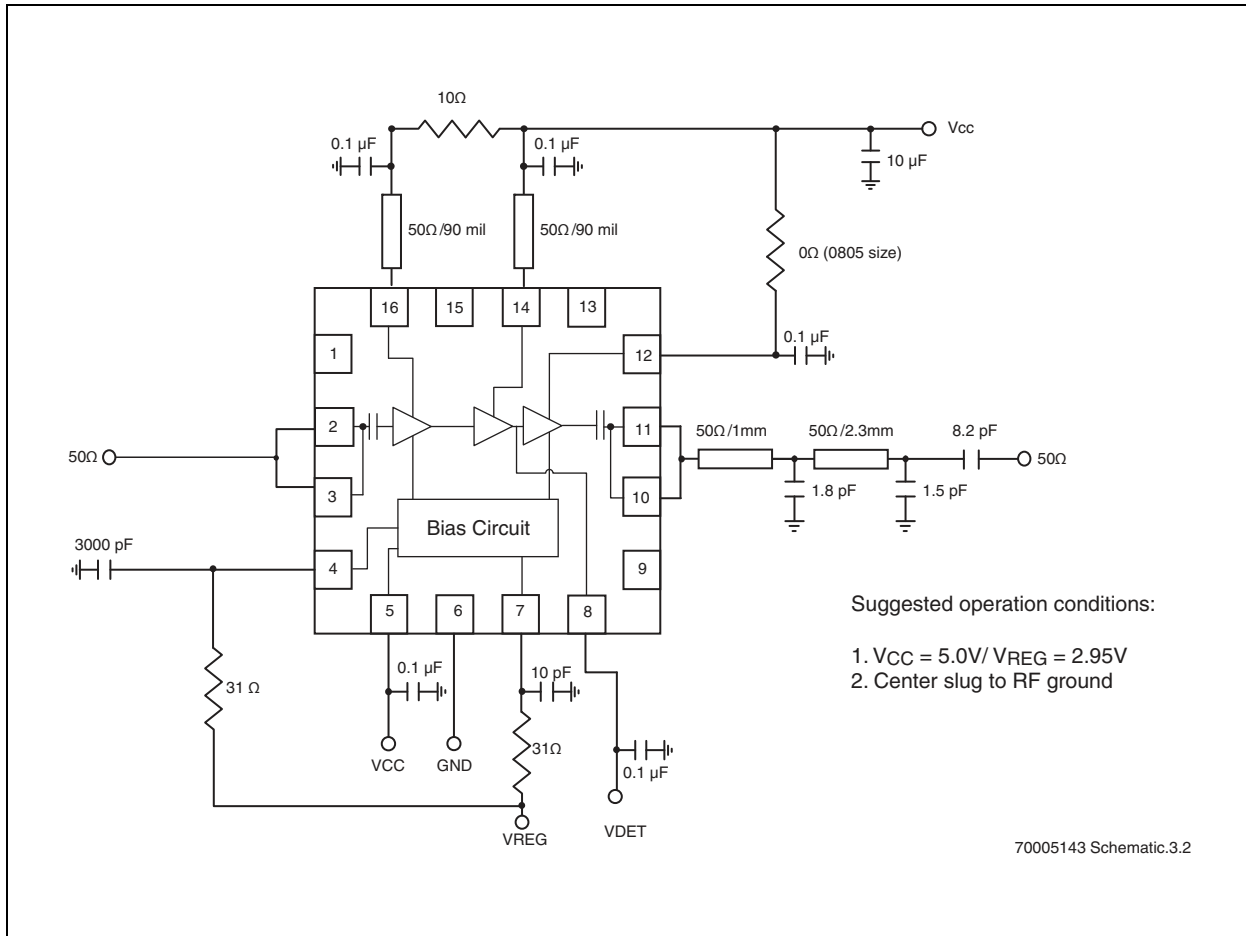

FIGURE 6-8: TYPICAL SCHEMATIC FOR 256 QAM APPLICATIONS



## 7.0 PACKAGING DIAGRAMS

### 16-Lead Ultra Thin Quad Flatpack No-Leads (QUCE/F) - 3x3 mm Body [UQFN]

**Note:** For the most current package drawings, please see the Microchip Packaging Specification located at <http://www.microchip.com/packaging>

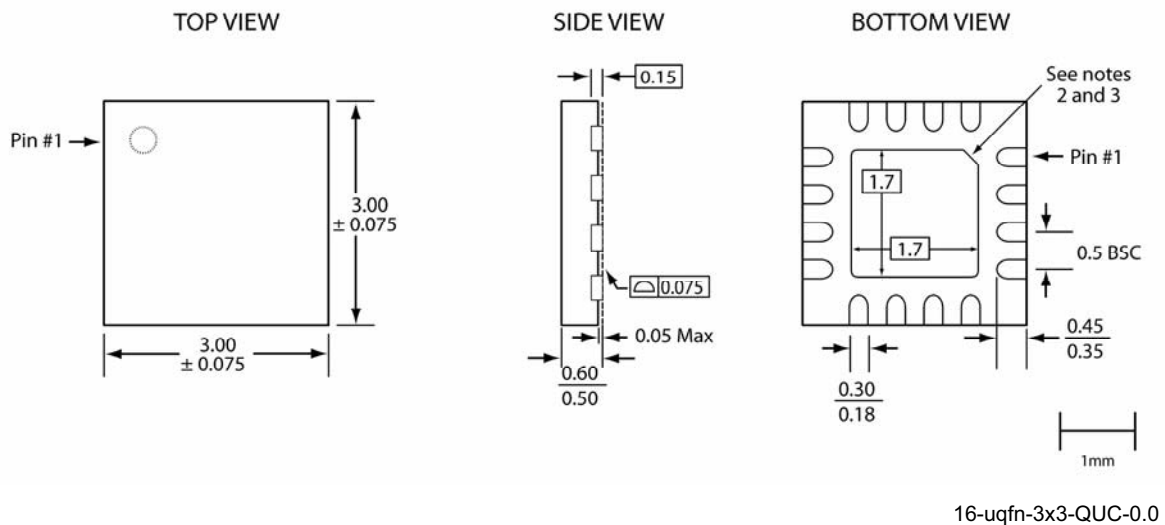

**Note:**

1. Complies with JEDEC JEP95 MO-248D, variant UEED-4 except external paddle nominal dimensions.
2. From the bottom view, the pin #1 indicator may be either a 45-degree chamfer or a half-circle notch.
3. The external paddle is electrically connected to the die back-side and possibly to certain VSS leads. This paddle can be soldered to the PC board; it is suggested to connect this paddle to the VSS of the unit. Connection of this paddle to any other voltage potential can result in shorts and/or electrical malfunction of the device.
4. Untoleranced dimensions are nominal target dimensions.
5. All linear dimensions are in millimeters (max/min).

**TABLE 7-1: REVISION HISTORY**

<b>Revision</b>	<b>Description</b>	<b>Date</b>
A	<ul style="list-style-type: none"><li>Initial release of data sheet</li></ul>	Apr 2014
B	<ul style="list-style-type: none"><li>Revised Tables <a href="#">5-1</a>, <a href="#">5-2</a>, and <a href="#">5-3</a> to reflect 3.3V information.</li></ul>	Feb 2015

## THE MICROCHIP WEB SITE

Microchip provides online support via our WWW site at [www.microchip.com](http://www.microchip.com). This web site is used as a means to make files and information easily available to customers. Accessible by using your favorite Internet browser, the web site contains the following information:

- **Product Support** – Data sheets and errata, application notes and sample programs, design resources, user's guides and hardware support documents, latest software releases and archived software
- **General Technical Support** – Frequently Asked Questions (FAQ), technical support requests, online discussion groups, Microchip consultant program member listing
- **Business of Microchip** – Product selector and ordering guides, latest Microchip press releases, listing of seminars and events, listings of Microchip sales offices, distributors and factory representatives

## CUSTOMER CHANGE NOTIFICATION SERVICE

Microchip's customer notification service helps keep customers current on Microchip products. Subscribers will receive e-mail notification whenever there are changes, updates, revisions or errata related to a specified product family or development tool of interest.

To register, access the Microchip web site at [www.microchip.com](http://www.microchip.com). Under "Support", click on "Customer Change Notification" and follow the registration instructions.

## CUSTOMER SUPPORT

Users of Microchip products can receive assistance through several channels:

- Distributor or Representative
- Local Sales Office
- Field Application Engineer (FAE)
- Technical Support

Customers should contact their distributor, representative or Field Application Engineer (FAE) for support. Local sales offices are also available to help customers. A listing of sales offices and locations is included in the back of this document.

**Technical support is available through the web site at: <http://microchip.com/support>**

## 8.0 PRODUCT IDENTIFICATION SYSTEM

To order or obtain information, e.g., on pricing or delivery, refer to the factory or the listed sales office.

<u>PART NO.</u>	<u>XXX</u>	
Device	Package	
Device: SST12CP11C		= 2.4 GHz High-Gain, High-Efficiency Power Amplifier
Package: QUCE		= UQFN (3mm x 3mm), 0.6 max thickness 16-contact
Evaluation Kit Flag	K	= Evaluation Kit

**Valid Combinations:**  
SST12CP11C-QUCE  
SST12CP11C-QUCE-K

---

---

**Note the following details of the code protection feature on Microchip devices:**

- Microchip products meet the specification contained in their particular Microchip Data Sheet.
- Microchip believes that its family of products is one of the most secure families of its kind on the market today, when used in the intended manner and under normal conditions.
- There are dishonest and possibly illegal methods used to breach the code protection feature. All of these methods, to our knowledge, require using the Microchip products in a manner outside the operating specifications contained in Microchip's Data Sheets. Most likely, the person doing so is engaged in theft of intellectual property.
- Microchip is willing to work with the customer who is concerned about the integrity of their code.
- Neither Microchip nor any other semiconductor manufacturer can guarantee the security of their code. Code protection does not mean that we are guaranteeing the product as “unbreakable.”

Code protection is constantly evolving. We at Microchip are committed to continuously improving the code protection features of our products. Attempts to break Microchip's code protection feature may be a violation of the Digital Millennium Copyright Act. If such acts allow unauthorized access to your software or other copyrighted work, you may have a right to sue for relief under that Act.

---

Information contained in this publication regarding device applications and the like is provided only for your convenience and may be superseded by updates. It is your responsibility to ensure that your application meets with your specifications. MICROCHIP MAKES NO REPRESENTATIONS OR WARRANTIES OF ANY KIND WHETHER EXPRESS OR IMPLIED, WRITTEN OR ORAL, STATUTORY OR OTHERWISE, RELATED TO THE INFORMATION, INCLUDING BUT NOT LIMITED TO ITS CONDITION, QUALITY, PERFORMANCE, MERCHANTABILITY OR FITNESS FOR PURPOSE. Microchip disclaims all liability arising from this information and its use. Use of Microchip devices in life support and/or safety applications is entirely at the buyer's risk, and the buyer agrees to defend, indemnify and hold harmless Microchip from any and all damages, claims, suits, or expenses resulting from such use. No licenses are conveyed, implicitly or otherwise, under any Microchip intellectual property rights.

#### **Trademarks**

The Microchip name and logo, the Microchip logo, dsPIC, FlashFlex, flexPWR, JukeBlox, KEELOQ, KEELOQ logo, Kleer, LANCheck, MediaLB, MOST, MOST logo, MPLAB, OptoLyzer, PIC, PICSTART, PIC<sup>32</sup> logo, RightTouch, SpyNIC, SST, SST Logo, SuperFlash and UNI/O are registered trademarks of Microchip Technology Incorporated in the U.S.A. and other countries.

The Embedded Control Solutions Company and mTouch are registered trademarks of Microchip Technology Incorporated in the U.S.A.

Analog-for-the-Digital Age, BodyCom, chipKIT, chipKIT logo, CodeGuard, dsPICDEM, dsPICDEM.net, ECAN, In-Circuit Serial Programming, ICSP, Inter-Chip Connectivity, KleerNet, KleerNet logo, MiWi, MPASM, MPF, MPLAB Certified logo, MPLIB, MPLINK, MultiTRAK, NetDetach, Omniscient Code Generation, PICDEM, PICDEM.net, PICkit, PICtail, RightTouch logo, REAL ICE, SQI, Serial Quad I/O, Total Endurance, TSHARC, USBCheck, VariSense, ViewSpan, WiperLock, Wireless DNA, and ZENA are trademarks of Microchip Technology Incorporated in the U.S.A. and other countries.

SQTP is a service mark of Microchip Technology Incorporated in the U.S.A.

Silicon Storage Technology is a registered trademark of Microchip Technology Inc. in other countries.

GestIC is a registered trademarks of Microchip Technology Germany II GmbH & Co. KG, a subsidiary of Microchip Technology Inc., in other countries.

All other trademarks mentioned herein are property of their respective companies.

© 2014, Microchip Technology Incorporated, Printed in the U.S.A., All Rights Reserved.

ISBN:978-1-63277-067-7

**QUALITY MANAGEMENT SYSTEM  
CERTIFIED BY DNV  
= ISO/TS 16949 =**

*Microchip received ISO/TS-16949:2009 certification for its worldwide headquarters, design and wafer fabrication facilities in Chandler and Tempe, Arizona; Gresham, Oregon and design centers in California and India. The Company's quality system processes and procedures are for its PIC® MCUs and dsPIC® DSCs, KEELOQ® code hopping devices, Serial EEPROMs, microperipherals, nonvolatile memory and analog products. In addition, Microchip's quality system for the design and manufacture of development systems is ISO 9001:2000 certified.*

## World Wide Sales and Service

### AMERICAS

**Corporate Office**  
2355 West Chandler Blvd.  
Chandler, AZ 85224-6199  
Tel: 480-792-7200  
Fax: 480-792-7277  
Technical Support:  
[http://www.microchip.com/  
support](http://www.microchip.com/support)  
Web Address:  
[www.microchip.com](http://www.microchip.com)

**Atlanta**  
Duluth, GA  
Tel: 678-957-9614  
Fax: 678-957-1455

**Austin, TX**  
Tel: 512-257-3370

**Boston**  
Westborough, MA  
Tel: 774-760-0087  
Fax: 774-760-0088

**Chicago**  
Itasca, IL  
Tel: 630-285-0071  
Fax: 630-285-0075

**Cleveland**  
Independence, OH  
Tel: 216-447-0464  
Fax: 216-447-0643

**Dallas**  
Addison, TX  
Tel: 972-818-7423  
Fax: 972-818-2924

**Detroit**  
Novi, MI  
Tel: 248-848-4000

**Houston, TX**  
Tel: 281-894-5983  
Indianapolis

**Noblesville, IN**  
Tel: 317-773-8323  
Fax: 317-773-5453

**Los Angeles**  
Mission Viejo, CA  
Tel: 949-462-9523  
Fax: 949-462-9608

**New York, NY**  
Tel: 631-435-6000

**San Jose, CA**  
Tel: 408-735-9110

**Canada - Toronto**  
Tel: 905-673-0699  
Fax: 905-673-6509

### ASIA/PACIFIC

**Asia Pacific Office**  
Suites 3707-14, 37th Floor  
Tower 6, The Gateway  
Harbour City, Kowloon

**Hong Kong**  
Tel: 852-2943-5100  
Fax: 852-2401-3431

**Australia - Sydney**  
Tel: 61-2-9868-6733  
Fax: 61-2-9868-6755

**China - Beijing**  
Tel: 86-10-8569-7000  
Fax: 86-10-8528-2104

**China - Chengdu**  
Tel: 86-28-8665-5511  
Fax: 86-28-8665-7889

**China - Chongqing**  
Tel: 86-23-8980-9588  
Fax: 86-23-8980-9500

**China - Dongguan**  
Tel: 86-769-8702-9880

**China - Hangzhou**  
Tel: 86-571-8792-8115  
Fax: 86-571-8792-8116

**China - Hong Kong SAR**  
Tel: 852-2943-5100  
Fax: 852-2401-3431

**China - Nanjing**  
Tel: 86-25-8473-2460  
Fax: 86-25-8473-2470

**China - Qingdao**  
Tel: 86-532-8502-7355  
Fax: 86-532-8502-7205

**China - Shanghai**  
Tel: 86-21-5407-5533  
Fax: 86-21-5407-5066

**China - Shenyang**  
Tel: 86-24-2334-2829  
Fax: 86-24-2334-2393

**China - Shenzhen**  
Tel: 86-755-8864-2200  
Fax: 86-755-8203-1760

**China - Wuhan**  
Tel: 86-27-5980-5300  
Fax: 86-27-5980-5118

**China - Xian**  
Tel: 86-29-8833-7252  
Fax: 86-29-8833-7256

### ASIA/PACIFIC

**China - Xiamen**  
Tel: 86-592-2388138  
Fax: 86-592-2388130

**China - Zhuhai**  
Tel: 86-756-3210040  
Fax: 86-756-3210049

**India - Bangalore**  
Tel: 91-80-3090-4444  
Fax: 91-80-3090-4123

**India - New Delhi**  
Tel: 91-11-4160-8631  
Fax: 91-11-4160-8632

**India - Pune**  
Tel: 91-20-3019-1500

**Japan - Osaka**  
Tel: 81-6-6152-7160  
Fax: 81-6-6152-9310

**Japan - Tokyo**  
Tel: 81-3-6880-3770  
Fax: 81-3-6880-3771

**Korea - Daegu**  
Tel: 82-53-744-4301  
Fax: 82-53-744-4302

**Korea - Seoul**  
Tel: 82-2-554-7200  
Fax: 82-2-558-5932 or  
82-2-558-5934

**Malaysia - Kuala Lumpur**  
Tel: 60-3-6201-9857  
Fax: 60-3-6201-9859

**Malaysia - Penang**  
Tel: 60-4-227-8870  
Fax: 60-4-227-4068

**Philippines - Manila**  
Tel: 63-2-634-9065  
Fax: 63-2-634-9069

**Singapore**  
Tel: 65-6334-8870  
Fax: 65-6334-8850

**Taiwan - Hsin Chu**  
Tel: 886-3-5778-366  
Fax: 886-3-5770-955

**Taiwan - Kaohsiung**  
Tel: 886-7-213-7828

**Taiwan - Taipei**  
Tel: 886-2-2508-8600  
Fax: 886-2-2508-0102

**Thailand - Bangkok**  
Tel: 66-2-694-1351  
Fax: 66-2-694-1350

### EUROPE

**Austria - Wels**  
Tel: 43-7242-2244-39  
Fax: 43-7242-2244-393

**Denmark - Copenhagen**  
Tel: 45-4450-2828  
Fax: 45-4485-2829

**France - Paris**  
Tel: 33-1-69-53-63-20  
Fax: 33-1-69-30-90-79

**Germany - Dusseldorf**  
Tel: 49-2129-3766400

**Germany - Munich**  
Tel: 49-89-627-144-0  
Fax: 49-89-627-144-44

**Germany - Pforzheim**  
Tel: 49-7231-424750

**Italy - Milan**  
Tel: 39-0331-742611  
Fax: 39-0331-466781

**Italy - Venice**  
Tel: 39-049-7625286

**Netherlands - Drunen**  
Tel: 31-416-690399  
Fax: 31-416-690340

**Poland - Warsaw**  
Tel: 48-22-3325737

**Spain - Madrid**  
Tel: 34-91-708-08-90  
Fax: 34-91-708-08-91

**Sweden - Stockholm**  
Tel: 46-8-5090-4654

**UK - Wokingham**  
Tel: 44-118-921-5800  
Fax: 44-118-921-5820