



TELECOMMUNICATION DRY COUPLING TRANSFORMER DESIGNED TO OPERATE AT A MAX LEVEL OF +7dBm AND TO REFLECT A PRIMARY SOURCE IMPEDANCE OF APPROXIMATELY 600ΩCT WITH 600ΩCT LOAD ON SECONDARY

MODEL NUMBER
TTC-108

REV. Status
 REVISION A
 01/08/92 HA
 REVISION B
 TEMECULA
 WAS CARSON
 01/26/93 TS
 REVISION C
 ADDED DCM21-PC
 MICROTRAN
 AND SAFETY
 01/20/96 TS
 REVISION D
 ADDED RoHS.
 UL1459 WAS
 UL1863.
 DIM 20.3(0.799)
 WAS 19.8(0.781)
 10/17/06 MP



- A. Electrical Specifications (@ 25 ° C)
- Pri Source Impedance; 600Ω CT
 - Sec Load Impedance; 600Ω CT
 - Operating Level; -45 dBm to +7 dBm
 - Insertion Loss; 1.4 dB MAX @ 1 KHz, 0 dBm
 - Frequency Response; ±0.5 dB 300 Hz to 3.5 KHz @ 0 dBm
 - Primary Impedance; 600 Ω +15%, -5% @ 300 Hz to 3.5 KHz, 0dBm
600 Ω +10%, -5% @ 500 Hz to 2.5 KHz, 0dBm
 - Longitudinal Balance; 60 dB MIN @ 200 Hz to 1 KHz
40 dBm MIN @ 4 KHz
 - DC Resistance; (1-3) = 44 Ω ±20%
(4-6) = 56 Ω ±20%
 - Turns Ratio; (1-3) : (4-6) = 1 : 1.00 ±2%
 - Dielectric Strength; 1500 Vrms 1 minute @ Pri to Sec, and Pri to Core
1000 Vrms 1 minute @ Sec to Core
 - Total Harmonic Distortion; 0.5% MAX @ 300 Hz to 3.5 KHz, 0 dBm
 - Induced Voltage; (1-3) 250 Vrms 5 KHz 1 minute
- B. Marking; TTC-108, TAMURA, DCM21-PC, MICROTRAN, safety agency logos, 196-date code and country of origin
- C. Safety; CSA-22.2 No. 66-M1988 File No. LR81383
UL 1459 File No. E142035

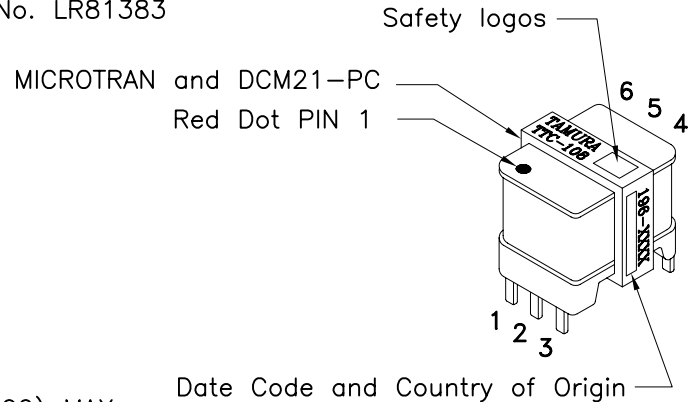
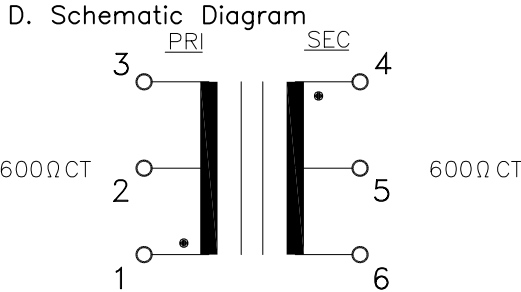

E. Mechanical Specifications

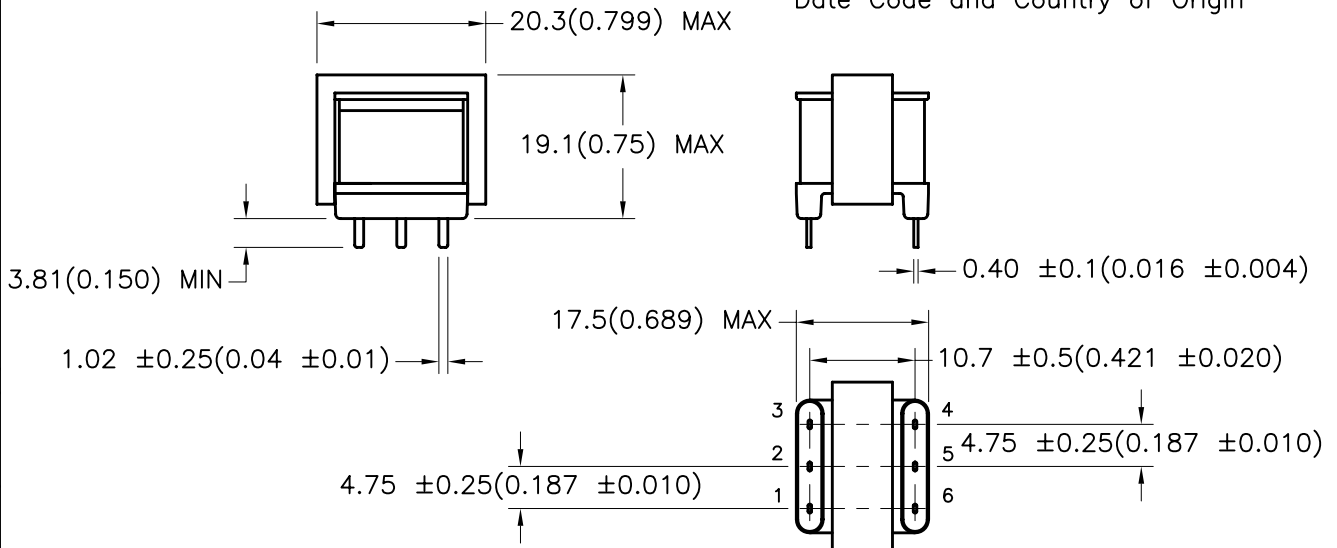

TOLERANCES (mm)	
≤ 4	± 0.2
4 ≤ 20	± 0.3
20 ≤ 50	± 0.4

PREPARED BY:
K. BRENNAN

ENGINEER:
M. PITCHAI

QUALITY CONTROL:
T. CLEM

APPROVED:
Y. SEKIGUCHI

DWG CONTROL NO. P-A1-10017
ACAD\TTC\A1100171.DWG

REV D TELECOMMUNICATION COUPLING TRANSFORMER

TAMURA CORPORATION OF AMERICA
43352 BUSINESS PARK DRIVE, TEMECULA, CA. 92590-6624
(951) 699-1270 FAX 9516769482

TTC-108
MODEL SPECIFICATION
DIM: mm[In] SCL: 1/1 SH: 1 OF 1

PROPRIETARY NOTICE: THIS DRAWING PRINT OR DOCUMENT AND SUBJECT MATTER DISCLOSED HEREIN ARE PROPRIETARY ITEMS TO WHICH TAMURA RETAINS THE EXCLUSIVE RIGHT OF DISSEMINATION, REPRODUCTION, MANUFACTURE AND SALE. THIS DRAWING, PRINT OR DOCUMENT IS SUBMITTED IN CONFIDENCE FOR CONSIDERATION BY THE RECIPIENT ALONE UNLESS PERMISSION FOR FURTHER DISCLOSURE IS EXPRESSLY GRANTED IN WRITING.