



L6756D

2/3/4 phase buck controller for VR10, VR11 and VR11.1 processor applications

Features

- LTB Technology[®] enhances load transient response
- 2 to 4 scalable phase operation
- Dual-edge asynchronous architecture
- PSI# input with programmable strategy
- Imon output
- Flexible driver support
- 7/8 bit programmable output - VR10/11.1 DAC
- 0.5% output voltage accuracy
- Full-differential current sense across DCR
- Integrated remote sense buffer
- Feedback disconnection protection
- Adjustable oscillator from 100 kHz to 1 MHz
- LSLess startup to manage pre-biased output
- Programmable soft-start
- Threshold sensitive enable pin for VTT Sensing
- VFQFPN40 6x6 mm package

Applications

- High-current VRM / VRD for desktop / server / workstation CPUs
- Graphic cards
- Low-voltage, high-current power supplies
- High-density DC / DC converters

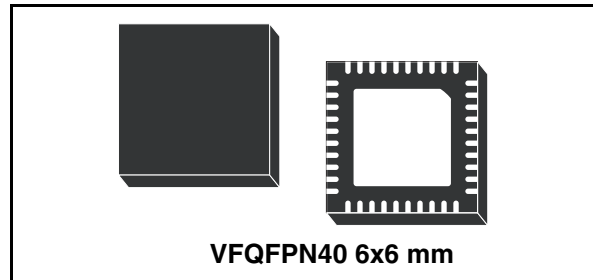

Description

L6756D is a two-to-four phase controller designed to power Intel's most demanding processors and, most in general, low-voltage, high-current power supplies. The device features LTB Technology[®] to provide the fastest response to load transients thus minimizing the output

filter composition.

L6756D embeds selectable DAC: output voltage is programmable up to 1.6000 V (Intel VR10 and VR11.x DACs) managing DVID transitions with $\pm 0.5\%$ output voltage accuracy over line, load and temperature variations.

The device assures fast protection against load over current and under / over voltage. Feedback disconnection prevents from damaging the load in case of misconnections in the system board.

Low-side-less start-up allows soft-start over pre-biased output avoiding dangerous current return through the main inductors as well as negative spike at the load side.

L6756D is available in VFQFPN 6x6 mm package

Table 1. Device summary

Order code	Package	Packing
L6756D	VFQFPN40	Tube
L6756DTR	VFQFPN40	Tape and reel

Contents

- 1 Typical application circuit and block diagram 4**
 - 1.1 Application circuit 4
 - 1.2 Block diagram 7

- 2 Pins description and connection diagrams 8**
 - 2.1 Pin descriptions 8
 - 2.2 Thermal data 11

- 3 Electrical specifications 12**
 - 3.1 Absolute maximum ratings 12
 - 3.2 Electrical characteristics 12

- 4 Device description and operation 19**

- 5 Output voltage positioning 20**
 - 5.1 Phase # programming 20
 - 5.2 Current reading and current sharing loop 21
 - 5.3 Output voltage load-line definition 22
 - 5.4 Output voltage offset 22
 - 5.5 Dynamic VID transitions 23
 - 5.6 Soft-start 24
 - 5.6.1 LSLESS start-up 25

- 6 Output voltage monitoring and protections 26**
 - 6.1 Overvoltage 26
 - 6.2 Feedback disconnection 26
 - 6.3 VR_RDY 27
 - 6.4 Over current 27

- 7 Low power-state management and PSI# 28**

- 8 Main oscillator 29**

9	System control loop compensation	30
9.1	Compensation network guidelines	31
9.2	LTB Technology®	32
10	Mechanical data and package dimensions	34
11	Revision history	35

Figure 2. Typical 3phase application circuit

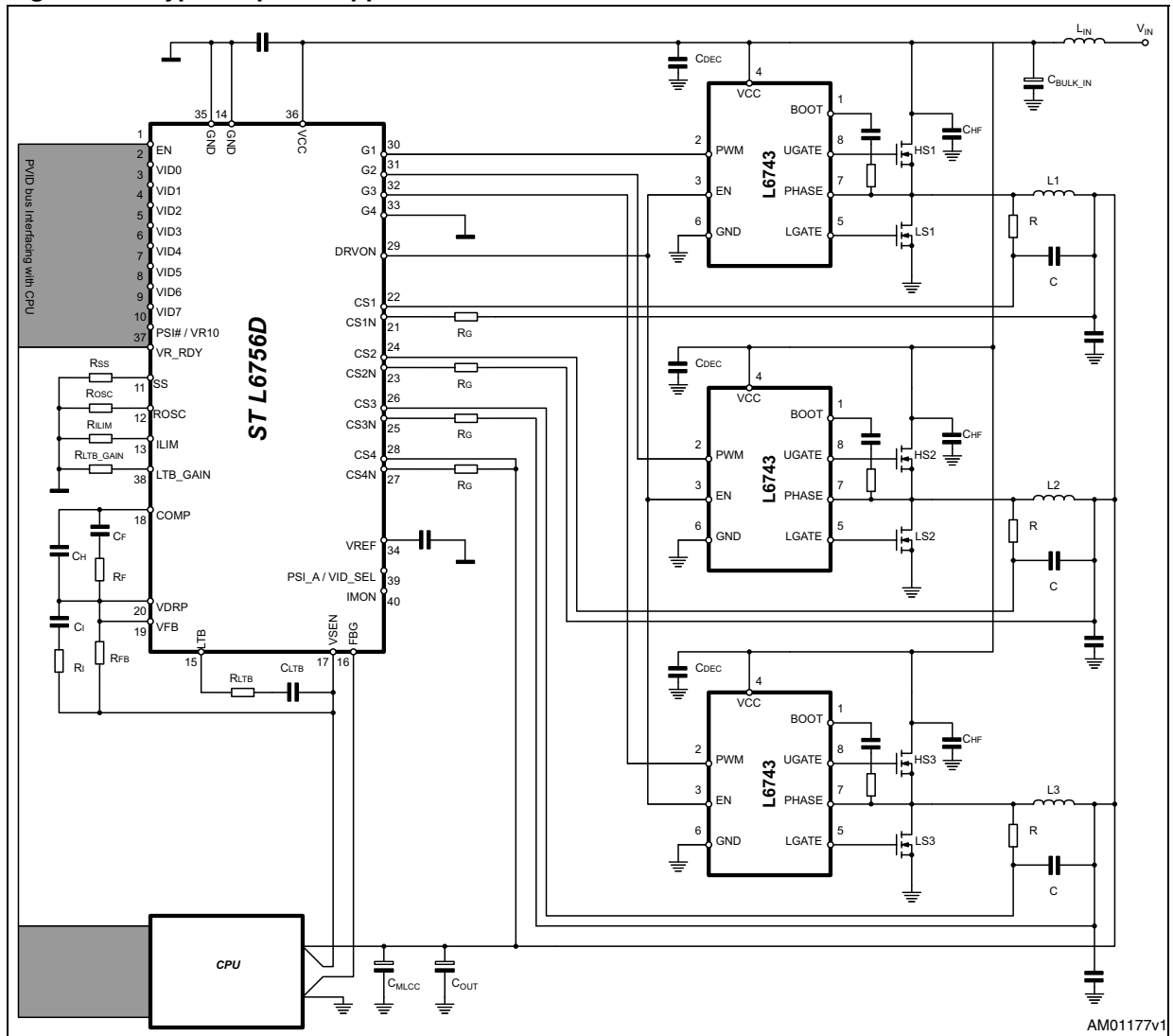

AM01177v1

Figure 3. Typical 2phase application circuit

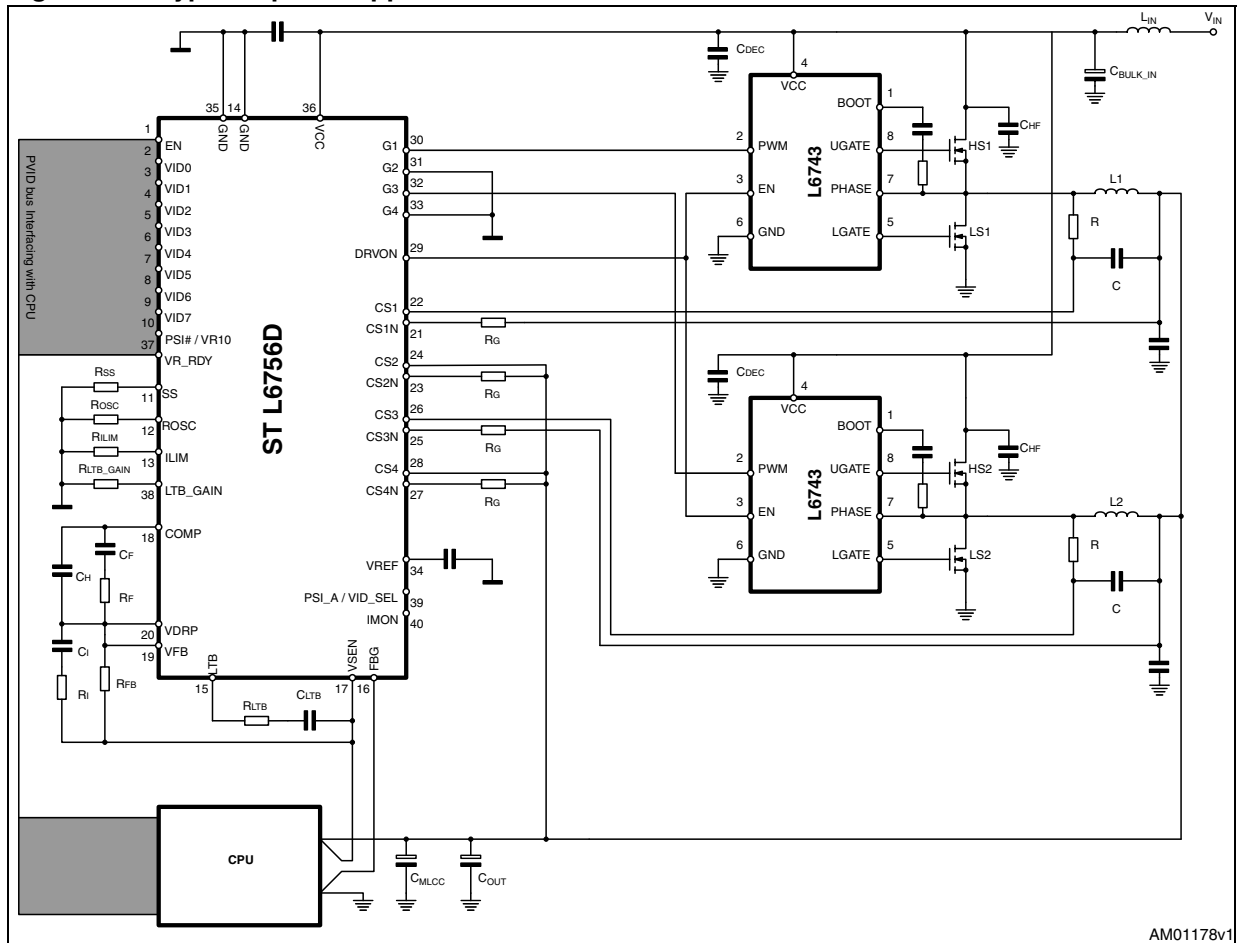

1.2 Block diagram

Figure 4. Block diagram

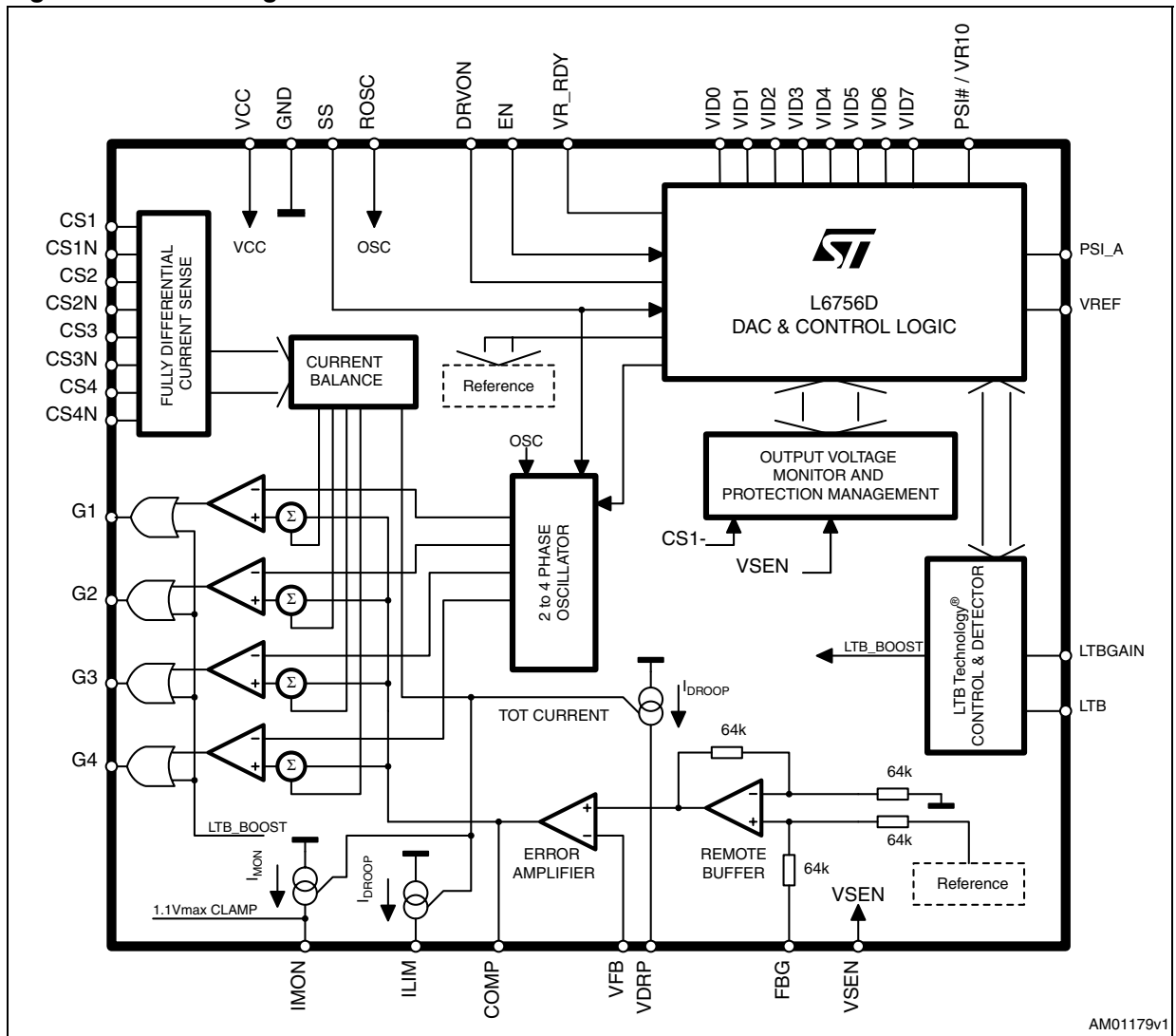

2 Pins description and connection diagrams

Figure 5. Pins connection (top view)

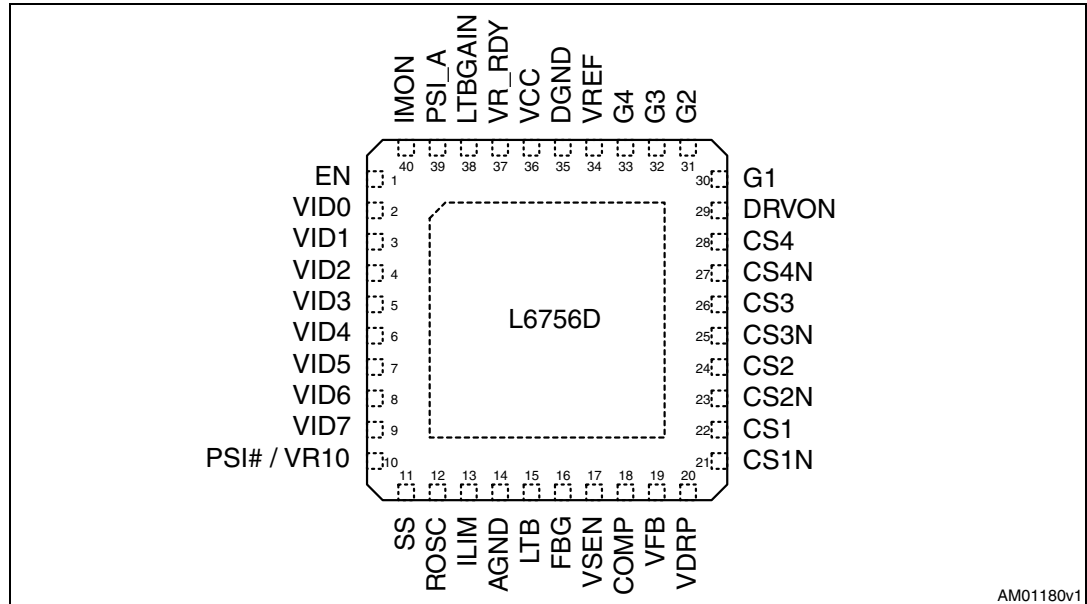

AM01180v1

2.1 Pin descriptions

Table 2. Pin description

Pin#	Name	Function
1	EN	VR enable. Internally pulled-up by 10 μ A to 3.3 V. Pull-low to disable the device, set free or pull up above turn-on threshold to enable the controller.
2 to 9	VID0 to VID7	Voltage IDentification pins. 3.3 V compatible, they allow programming output voltage as specified in Table 6 and Table 7 according to VR10/1 pin status.
10	PSI# / VR10	According to the status of PSI_A, the functionality of this pin changes as below: <i>PSI#</i> : Power state indicator input. Connect to the PSI# pin on the CPU to manage low-power state. When asserted (pulled low), the controller will act as programmed on the PSI_A pin. <i>VR10</i> : It allows selecting between VR10 (short to SGND, See Table 6) or VR11 (floating, See Table 7) DACs.
11	SS	By connecting a resistor R_{SS} to GND, it allows programming the soft-start time. soft-start time T_{SS} will proportionally change with a gain of 18.52 [μ s / $k\Omega$]. Connect 27 $k\Omega$ resistor to program $T_2 = 500 \mu$ s. The same slope implemented to reach V_{BOOT} has to be considered also when the reference moves from V_{BOOT} to the programmed VID code. The pin is kept to a fixed 1.24 V.

Table 2. Pin description (continued)

Pin#	Name	Function
12	ROSC	Oscillator pin. It allows programming the switching frequency F_{SW} of each channel: the equivalent switching frequency at the load side results in being multiplied by the phase number N. Frequency is programmed according to the resistor connected from the pin to GND or VCC with a gain of 10 kHz/ μ A. Leaving the pin floating programs a switching frequency of 200 kHz per phase.
13	ILIM	Over current SET pin. Connect to GND through a R_{ILIM} resistor to set the OC threshold. this pin sources a copy of the DROOP current; OC is set when the voltage at the pin crosses 1.7 V (typ). See Section 6.4 for details.
14	GND	All the internal references are referred to this pin. Connect to the PCB Signal Ground.
15	LTB	Load transient boost Technology [®] input pin. See Section 9.2 for details.
16	FBG	Remote ground sense. Connect to the negative side of the load to perform remote sense.
17	VSEN	Output voltage monitor, manages OVP and UVP protections. Connect to the positive side of the load to perform remote sense. A fixed 50 μ A current is sunk through this pin to implement small positive offset for the regulated voltage. See Section 5.4 for details.
18	COMP	Error Amplifier Output. Connect with an $R_F - C_F // C_H$ to VFB. The device cannot be disabled by pulling low this pin.
19	VFB	error amplifier inverting input. Connect with a resistor R_{FB} to VSEN and with an $R_F - C_F // C_H$ to COMP.
20	VDRP	A current proportional to the total current read is sourced from this pin according to the current reading gain. Short to VFB to implement voltage positioning or connect to GND through a resistor and filter with 1 nF capacitor to implement an additional load indicator.
21	CS1N	Channel 1 current sense negative input. Connect through a R_g resistor to the output-side of the channel inductor.
22	CS1	Channel 1 current sense positive input. Connect through an R-C filter to the phase-side of the channel 1 inductor.
23	CS2N	Channel 2 current sense negative input. Connect through a R_g resistor to the output-side of the channel inductor. When working at 2 phase, still connect through R_g to CS2 and then to the regulated voltage.
24	CS2	Channel 2 current sense positive input. Connect through an R-C filter to the phase-side of the channel 2 inductor. When working at 2 phase, short to the regulated voltage.
25	CS3N	Channel 3 current sense negative input. Connect through a R_g resistor to the output-side of the channel inductor.
26	CS3	Channel 3 current sense positive input. Connect through an R-C filter to the phase-side of the channel 3 inductor.
27	CS4N	Channel 4 current sense negative input. Connect through a R_g resistor to the output-side of the channel inductor. When working at 2 or 3 phase, still connect through R_g to CS3 and then to the regulated voltage.

Table 2. Pin description (continued)

Pin#	Name	Function
28	CS4	Channel 4 current sense positive input. Connect through an R-C filter to the phase-side of the channel 4 inductor. When working at 2 or 3 phase, short to the regulated voltage.
29	DRVON	External driver enable. CMOS output used to control the external driver status: pulled-low to manage HiZ conditions or pulled-high for normal driver switching.
30 to 33	G1 to G4	PWM outputs. Connect to external drivers PWM inputs. The device is able to manage HiZ status by setting the pins floating. By shorting to GND G4 or G2 and G4, it is possible to program the device to work at 3 or 2 phase respectively.
34	VREF	This pin provide a 2.5 V reference. Filter with 1 nF (max) to SGND.
35	GND	All the internal references are referred to this pin. Connect to the PCB signal ground.
36	VCC	Device power supply. Operative voltage is 12 V \pm 15 %. Filter with at least 1 μ F MLCC vs. ground.
37	VR_RDY	Open drain output set free after SS has finished and pulled low when triggering any protection. Pull up to a voltage lower than 3.3 V (typ), if not used it can be left floating.
38	LTB_GAIN	Load transient boost technology [®] gain pin. See Section 9.2 for details.
39	PSI_A	PSI action configuration pin. This pins configures the functionality of the PSI# / VR10 pin according to Table 9 as follow: VR10: Short to SGND to configure the VID_SEL functionality. The controller will not manage low power-states but will be backward compatible with VR10 / VR11 platforms. PSI#: The device will work in VR11 mode and perform low power-states management through the PSI# pin. See Section 7 for details.
40	IMON	Current monitor output. A current proportional to the read current is sourced from this pin. Connect through a resistor R _{MON} to FBG to implement a load indicator. Connect the load indicator directly to VR11.1 CPUs. The pin voltage is clamped to 1.1V max to preserve the CPU from excessive voltages.
	Thermal pad	Thermal pad connects the silicon substrate and makes good thermal contact with the PCB. Connect to the PGND plane.

2.2 Thermal data

Table 3. Thermal data

Symbol	Parameter	Value	Unit
R_{thJA}	Thermal resistance junction to ambient (Device soldered on 2s2p PC board)	35	°C/W
R_{thJC}	Thermal resistance junction to case	1	°C/W
T_{MAX}	Maximum junction temperature	150	°C
T_{STG}	Storage temperature range	-40 to 150	°C
T_J	Junction temperature range	0 to 125	°C

3 Electrical specifications

3.1 Absolute maximum ratings

Table 4. Absolute maximum ratings

Symbol	Parameter	Value	Unit
V_{CC}	to PGND	15	V
	All other Pins to PGNDx	-0.3 to 3.6	V

3.2 Electrical characteristics

Table 5. Electrical characteristics

($V_{CC} = 12\text{ V} \pm 15\%$, $T_J = 0\text{ }^\circ\text{C}$ to $70\text{ }^\circ\text{C}$ unless otherwise specified)

Symbol	Parameter	Test conditions	Min.	Typ.	Max.	Unit
Supply current and power-on						
I_{CC}	VCC supply current			25		mA
$UVLO_{VCC}$	VCC turn-ON	VCC rising			9.75	V
	VCC turn-OFF	VCC falling	7			V
Oscillator, soft-start and ENABLE						
F_{SW}	Main oscillator accuracy		185	200	215	kHz
	Oscillator adjustability	$R_{OSC} = 33\text{ k}\Omega$		500		kHz
ΔV_{OSC}	PWM ramp amplitude			1.5		V
FAULT	Voltage at pin OSC	OV, UV latch active	3		3.6	V
SOFT-START		T_{D1} - initial delay	1	2	3	ms
		T_{D2} - $R_{SS} = 27\text{ k}\Omega$	400	500	600	μs
		T_{D3} - V_{BOOT}	100	200	300	μs
		Boot voltage - V_{BOOT}	1.026	1.081	1.136	V
EN		V_{EN} rising	0.80	0.85	0.90	V
		Hysteresis		100		mV
Reference and DAC						
K_{VID}	V_{OUT} accuracy	V_{SEN} to V_{CORE} ; FBG to GND_{CORE}	-0.5		0.5	%
I_{OS}	OFFSET	$V_{SEN} = 0.5000\text{ V}$ to 1.6000 V	-40	-50	-60	μA
A_0	EA DC gain			130		dB
SR	Slew rate	COMP to SGND = 10 pF		25		V/ μs
VID_{IL}	VID threshold,	Input low			0.3	V
VID_{IH}		Input high	0.8			V

Table 5. Electrical characteristics (continued)
($V_{CC} = 12\text{ V} \pm 15\%$, $T_J = 0\text{ }^\circ\text{C}$ to $70\text{ }^\circ\text{C}$ unless otherwise specified)

Symbol	Parameter	Test conditions	Min.	Typ.	Max.	Unit
PSI#/VR10	Input threshold	Input low			0.3	V
		Input high	0.8			V
VREF	Reference voltage		2.450	2.500	2.550	V
LTBGAIN	LTBGAIN voltage			1.24		V
Differential current sense and current monitor						
k_{IDROOP}	DROOP accuracy	$R_g = 1\text{ k}\Omega$; $I_{DROOP} < 100\text{ }\mu\text{A}$	-4		4	μA
k_{IMON}	IMON accuracy	$R_g = 1\text{ k}\Omega$; $I_{MON} < 100\text{ }\mu\text{A}$	-6		6	μA
k_{ILIM}	ILIM accuracy	$R_g = 1\text{ k}\Omega$; $I_{LIM} < 100\text{ }\mu\text{A}$	-8		8	μA
PWM outputs						
Gx	Output high	$I = 1\text{ mA}$	3			V
	Output low	$I = -1\text{ mA}$			0.2	V
I_{Gx}	Test current			10		μA
DRVON	Output low	$I = -5\text{ mA}$			0.4	V
Protections						
OVP		VSEN rising; wrt Ref.	150	175	200	mV
UVP	Under voltage protection	VSEN falling; wrt Ref; Ref > 500mV		-400		mV
VR_RDY	Voltage low	$I_{VR_RDY} = -4\text{ mA}$			0.4	V
$V_{FB-DISC}$	FB disconnection	V_{CSN} rising, above VSEN	550	650	750	mV
FBG DISC	FBG disconnection	EA NI input wrt VID	400	500	600	mV
V_{ILIM_OC}	OC threshold	V_{ILIM} rising	1.6	1.7	1.8	V
		V_{ILIM} rising, during DVID		2.5		V

Table 6. Voltage identification (VID) for Intel VR11.x mode

HEX code VID[7:0]		Output voltage	HEX code VID[7:0]		Output voltage	HEX code VID[7:0]		Output voltage	HEX code VID[7:0]		Output voltage
0	0	OFF	4	0	1.21250	8	0	0.81250	C	0	0.41250
0	1	OFF	4	1	1.20625	8	1	0.80625	C	1	0.40625
0	2	1.60000	4	2	1.20000	8	2	0.80000	C	2	0.40000
0	3	1.59375	4	3	1.19375	8	3	0.79375	C	3	0.39375
0	4	1.58750	4	4	1.18750	8	4	0.78750	C	4	0.38750
0	5	1.58125	4	5	1.18125	8	5	0.78125	C	5	0.38125
0	6	1.57500	4	6	1.17500	8	6	0.77500	C	6	0.37500
0	7	1.56875	4	7	1.16875	8	7	0.76875	C	7	0.36875
0	8	1.56250	4	8	1.16250	8	8	0.76250	C	8	0.36250
0	9	1.55625	4	9	1.15625	8	9	0.75625	C	9	0.35625
0	A	1.55000	4	A	1.15000	8	A	0.75000	C	A	0.35000
0	B	1.54375	4	B	1.14375	8	B	0.74375	C	B	0.34375
0	C	1.53750	4	C	1.13750	8	C	0.73750	C	C	0.33750
0	D	1.53125	4	D	1.13125	8	D	0.73125	C	D	0.33125
0	E	1.52500	4	E	1.12500	8	E	0.72500	C	E	0.32500
0	F	1.51875	4	F	1.11875	8	F	0.71875	C	F	0.31875
1	0	1.51250	5	0	1.11250	9	0	0.71250	D	0	0.31250
1	1	1.50625	5	1	1.10625	9	1	0.70625	D	1	0.30625
1	2	1.50000	5	2	1.10000	9	2	0.70000	D	2	0.30000
1	3	1.49375	5	3	1.09375	9	3	0.69375	D	3	0.29375
1	4	1.48750	5	4	1.08750	9	4	0.68750	D	4	0.28750
1	5	1.48125	5	5	1.08125	9	5	0.68125	D	5	0.28125
1	6	1.47500	5	6	1.07500	9	6	0.67500	D	6	0.27500
1	7	1.46875	5	7	1.06875	9	7	0.66875	D	7	0.26875
1	8	1.46250	5	8	1.06250	9	8	0.66250	D	8	0.26250
1	9	1.45625	5	9	1.05625	9	9	0.65625	D	9	0.25625
1	A	1.45000	5	A	1.05000	9	A	0.65000	D	A	0.25000
1	B	1.44375	5	B	1.04375	9	B	0.64375	D	B	0.24375
1	C	1.43750	5	C	1.03750	9	C	0.63750	D	C	0.23750
1	D	1.43125	5	D	1.03125	9	D	0.63125	D	D	0.23125
1	E	1.42500	5	E	1.02500	9	E	0.62500	D	E	0.22500
1	F	1.41875	5	F	1.01875	9	F	0.61875	D	F	0.21875
2	0	1.41250	6	0	1.01250	A	0	0.61250	E	0	0.21250
2	1	1.40625	6	1	1.00625	A	1	0.60625	E	1	0.20625

Table 6. Voltage identification (VID) for Intel VR11.x mode (continued)

HEX code VID[7:0]		Output voltage	HEX code VID[7:0]		Output voltage	HEX code VID[7:0]		Output voltage	HEX code VID[7:0]		Output voltage
2	2	1.40000	6	2	1.00000	A	2	0.60000	E	2	0.20000
2	3	1.39375	6	3	0.99375	A	3	0.59375	E	3	0.19375
2	4	1.38750	6	4	0.98750	A	4	0.58750	E	4	0.18750
2	5	1.38125	6	5	0.98125	A	5	0.58125	E	5	0.18125
2	6	1.37500	6	6	0.97500	A	6	0.57500	E	6	0.17500
2	7	1.36875	6	7	0.96875	A	7	0.56875	E	7	0.16875
2	8	1.36250	6	8	0.96250	A	8	0.56250	E	8	0.16250
2	9	1.35625	6	9	0.95625	A	9	0.55625	E	9	0.15625
2	A	1.35000	6	A	0.95000	A	A	0.55000	E	A	0.15000
2	B	1.34375	6	B	0.94375	A	B	0.54375	E	B	0.14375
2	C	1.33750	6	C	0.93750	A	C	0.53750	E	C	0.13750
2	D	1.33125	6	D	0.93125	A	D	0.53125	E	D	0.13125
2	E	1.32500	6	E	0.92500	A	E	0.52500	E	E	0.12500
2	F	1.31875	6	F	0.91875	A	F	0.51875	E	F	0.11875
3	0	1.31250	7	0	0.91250	B	0	0.51250	F	0	0.11250
3	1	1.30625	7	1	0.90625	B	1	0.50625	F	1	0.10625
3	2	1.30000	7	2	0.90000	B	2	0.50000	F	2	0.10000
3	3	1.29375	7	3	0.89375	B	3	0.49375	F	3	0.09375
3	4	1.28750	7	4	0.88750	B	4	0.48750	F	4	0.08750
3	5	1.28125	7	5	0.88125	B	5	0.48125	F	5	0.08125
3	6	1.27500	7	6	0.87500	B	6	0.47500	F	6	0.07500
3	7	1.26875	7	7	0.86875	B	7	0.46875	F	7	0.06875
3	8	1.26250	7	8	0.86250	B	8	0.46250	F	8	0.06250
3	9	1.25625	7	9	0.85625	B	9	0.45625	F	9	0.05625
3	A	1.25000	7	A	0.85000	B	A	0.45000	F	A	0.05000
3	B	1.24375	7	B	0.84375	B	B	0.44375	F	B	0.04375
3	C	1.23750	7	C	0.83750	B	C	0.43750	F	C	0.03750
3	D	1.23125	7	D	0.83125	B	D	0.43125	F	D	0.03125
3	E	1.22500	7	E	0.82500	B	E	0.42500	F	E	OFF
3	F	1.21875	7	F	0.81875	B	F	0.41875	F	F	OFF

Table 7. Voltage identifications (VID) for Intel VR10 mode + 6.25 mV

VID4	VID3	VID2	VID1	VID0	VID5	VID6	Output voltage	VID4	VID3	VID2	VID1	VID0	VID5	VID6	Output voltage
0	1	0	1	0	1	1	1.60000	1	1	0	1	0	1	1	1.20000
0	1	0	1	0	1	0	1.59375	1	1	0	1	0	1	0	1.19375
0	1	0	1	1	0	1	1.58750	1	1	0	1	1	0	1	1.18750
0	1	0	1	1	0	0	1.58125	1	1	0	1	1	0	0	1.18125
0	1	0	1	1	1	1	1.57500	1	1	0	1	1	1	1	1.17500
0	1	0	1	1	1	0	1.56875	1	1	0	1	1	1	0	1.16875
0	1	1	0	0	0	1	1.56250	1	1	1	0	0	0	1	1.16250
0	1	1	0	0	0	0	1.55625	1	1	1	0	0	0	0	1.15625
0	1	1	0	0	1	1	1.55000	1	1	1	0	0	1	1	1.15000
0	1	1	0	0	1	0	1.54375	1	1	1	0	0	1	0	1.14375
0	1	1	0	1	0	1	1.53750	1	1	1	0	1	0	1	1.13750
0	1	1	0	1	0	0	1.53125	1	1	1	0	1	0	0	1.13125
0	1	1	0	1	1	1	1.52500	1	1	1	0	1	1	1	1.12500
0	1	1	0	1	1	0	1.51875	1	1	1	0	1	1	0	1.11875
0	1	1	1	0	0	1	1.51250	1	1	1	1	0	0	1	1.11250
0	1	1	1	0	0	0	1.50625	1	1	1	1	0	0	0	1.10625
0	1	1	1	0	1	1	1.50000	1	1	1	1	0	1	1	1.10000
0	1	1	1	0	1	0	1.49375	1	1	1	1	0	1	0	1.09375
0	1	1	1	1	0	1	1.48750	1	1	1	1	1	0	1	OFF
0	1	1	1	1	0	0	1.48125	1	1	1	1	1	0	0	OFF
0	1	1	1	1	1	1	1.47500	1	1	1	1	1	1	1	OFF
0	1	1	1	1	1	0	1.46875	1	1	1	1	1	1	0	OFF
1	0	0	0	0	0	1	1.46250	0	0	0	0	0	0	1	1.08750
1	0	0	0	0	0	0	1.45625	0	0	0	0	0	0	0	1.08125
1	0	0	0	0	1	1	1.45000	0	0	0	0	0	1	1	1.07500
1	0	0	0	0	1	0	1.44375	0	0	0	0	0	1	0	1.06875
1	0	0	0	1	0	1	1.43750	0	0	0	0	1	0	1	1.06250
1	0	0	0	1	0	0	1.43125	0	0	0	0	1	0	0	1.05625
1	0	0	0	1	1	1	1.42500	0	0	0	0	1	1	1	1.05000
1	0	0	0	1	1	0	1.41875	0	0	0	0	1	1	0	1.04375
1	0	0	1	0	0	1	1.41250	0	0	0	1	0	0	1	1.03750
1	0	0	1	0	0	0	1.40625	0	0	0	1	0	0	0	1.03125
1	0	0	1	0	1	1	1.40000	0	0	0	1	0	1	1	1.02500
1	0	0	1	0	1	0	1.39375	0	0	0	1	0	1	0	1.01875

Table 7. Voltage identifications (VID) for Intel VR10 mode + 6.25 mV (continued)

VID4	VID3	VID2	VID1	VID0	VID5	VID6	Output voltage	VID4	VID3	VID2	VID1	VID0	VID5	VID6	Output voltage
1	0	0	1	1	0	1	1.38750	0	0	0	1	1	0	1	1.01250
1	0	0	1	1	0	0	1.38125	0	0	0	1	1	0	0	1.00625
1	0	0	1	1	1	1	1.37500	0	0	0	1	1	1	1	1.00000
1	0	0	1	1	1	0	1.36875	0	0	0	1	1	1	0	0.99375
1	0	1	0	0	0	1	1.36250	0	0	1	0	0	0	1	0.98750
1	0	1	0	0	0	0	1.35625	0	0	1	0	0	0	0	0.98125
1	0	1	0	0	1	1	1.35000	0	0	1	0	0	1	1	0.97500
1	0	1	0	0	1	0	1.34375	0	0	1	0	0	1	0	0.96875
1	0	1	0	1	0	1	1.33750	0	0	1	0	1	0	1	0.96250
1	0	1	0	1	0	0	1.33125	0	0	1	0	1	0	0	0.95625
1	0	1	0	1	1	1	1.32500	0	0	1	0	1	1	1	0.95000
1	0	1	0	1	1	0	1.31875	0	0	1	0	1	1	0	0.94375
1	0	1	1	0	0	1	1.31250	0	0	1	1	0	0	1	0.93750
1	0	1	1	0	0	0	1.30625	0	0	1	1	0	0	0	0.93125
1	0	1	1	0	1	1	1.30000	0	0	1	1	0	1	1	0.92500
1	0	1	1	0	1	0	1.29375	0	0	1	1	0	1	0	0.91875
1	0	1	1	1	0	1	1.28750	0	0	1	1	1	0	1	0.91250
1	0	1	1	1	0	0	1.28125	0	0	1	1	1	0	0	0.90625
1	0	1	1	1	1	1	1.27500	0	0	1	1	1	1	1	0.90000
1	0	1	1	1	1	0	1.26875	0	0	1	1	1	1	0	0.89375
1	1	0	0	0	0	1	1.26250	0	1	0	0	0	0	1	0.88750
1	1	0	0	0	0	0	1.25625	0	1	0	0	0	0	0	0.88125
1	1	0	0	0	1	1	1.25000	0	1	0	0	0	1	1	0.87500
1	1	0	0	0	1	0	1.24375	0	1	0	0	0	1	0	0.86875
1	1	0	0	1	0	1	1.23750	0	1	0	0	1	0	1	0.86250
1	1	0	0	1	0	0	1.23125	0	1	0	0	1	0	0	0.85625
1	1	0	0	1	1	1	1.22500	0	1	0	0	1	1	1	0.85000
1	1	0	0	1	1	0	1.21875	0	1	0	0	1	1	0	0.84375
1	1	0	1	0	0	1	1.21250	0	1	0	1	0	0	1	0.83750
1	1	0	1	0	0	0	1.20625	0	1	0	1	0	0	0	0.83125

Table 8. Gate output connections for phase # definition

Mode	Gate output connections			
	G1	G2	G3	G4
2-phase	to driver	GND	to driver	GND
3-phase	to driver	to driver	to driver	GND
4-phase	to driver	to driver	to driver	to driver

4 Device description and operation

L6756D is a programmable two-to-four phase PWM controller providing complete control logic and protections for a high performance step-down DC-DC voltage regulator optimized for advanced microprocessor power supply. The device is a dual-edge asynchronous PWM controller featuring patented LTB Technology[®]: through a load transient detector, it turns on simultaneously all the phases allowing to minimize output voltage deviation so minimizing the system cost by providing the fastest response to a load transition.

Multi-phase buck is the simplest and most cost-effective topology employable to satisfy the increasing current demand of newer microprocessors and modern high current VRM modules. It allows distributing equally load and power between the phases using smaller, cheaper and most common external power MOSFETs and inductors. Moreover, thanks to the equal phase shift between each phase, the input and output capacitor count results in being reduced. Phase interleaving causes in fact input rms current and output ripple voltage reduction and show an effective output switching frequency increase: the 200 kHz free-Running frequency per phase, externally adjustable through a resistor, results multiplied on the output by the number of phases.

L6756D permits easy system design by allowing current reading across inductor in fully differential mode. Also a sense resistor in series to the inductor can be considered to improve reading precision. The current information read corrects the PWM output in order to equalize the average current carried by each phase.

The controller includes multiple DACs, selectable through an apposite pin, allowing compatibility with Intel VR10, VR11 and VR11.1 processors specifications, also performing D-VID transitions accordingly.

The device is VR11.1 compatible implementing the Imon signal and managing the PSI# signal to enhance the system performances at low current in low power-states.

Low-side-less start-up allows soft-start over pre-biased output avoiding dangerous current return through the main inductors as well as negative spike at the load side.

L6756D provides overvoltage protection to protect the load from dangerous over stress latching immediately by turning ON the lower driver and driving high the FAULT pin.

The device is available in a compact VFQFPN40 with 6x6 mm body package.

5 Output voltage positioning

Output voltage positioning is performed by selecting the controller operation mode (*VR10*, *VR11* or *VR11.1*) and by programming the droop function and offset to the reference of both the sections (See [Figure 6](#)). The controller reads the current delivered by monitoring the voltage drop across the Inductors DCR. The current (I_{DROOP}) sourced from the DROOP pin, directly proportional to the read current, causes the output voltage to vary according to the external R_{FB} resistor so implementing the desired load-line effect. A fixed current (I_{OS}) is sunk through the VSEN pins causing the output voltage to be offset according to the resistance R_{OS} connected.

L6756D allows to recover from GND losses in order to regulate remotely the programmed voltage without any additional external components. In this way, the output voltage programmed is regulated compensating for board and socket losses. Keeping the sense traces parallel and guarded by a power plane results in common mode coupling for any picked-up noise.

Both DROOP and OFFSET function can be disabled. In case DROOP effect is not desired, the current information source from the DROOP pin may be used to implement a secondary load indicator as reported in [Section 5.3](#).

Figure 6. Voltage positioning

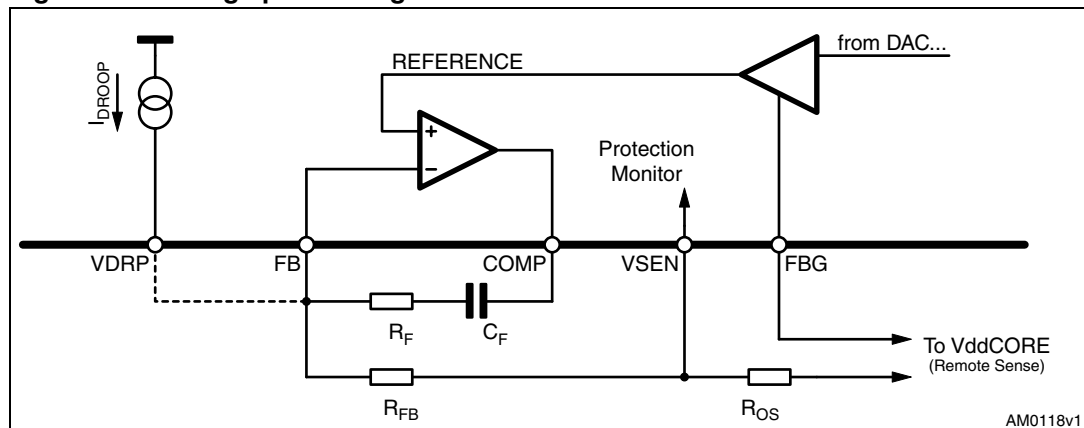

5.1 Phase # programming

L6756D implements a flexible 2 to 4 interleaved-phase converter. To program the desired number of phase, refer to [Table 8](#).

For the disabled phase(s), the current reading pins need to be properly connected to avoid errors in current-sharing and voltage-positioning: CSx needs to be connected to the regulated output voltage while CSxN needs to be connected to CSx with the same R_G resistor used for the other phases.

5.2 Current reading and current sharing loop

L6756D embeds a flexible, fully-differential current sense circuitry that is able to read across inductor parasitic resistance or across a sense resistor placed in series to the inductor element. The fully-differential current reading rejects noise and allows placing sensing element in different locations without affecting the measurement's accuracy. The trans-conductance ratio is issued by the external resistor R_G placed outside the chip between CSxN pin toward the reading points. The current sense circuit always tracks the current information, the pin CSx is used as a reference keeping the CSxN pin to this voltage. To correctly reproduce the inductor current an R-C filtering network must be introduced in parallel to the sensing element. The current that flows from the CSxN pin is then given by the following equation (See [Figure 7](#)):

$$I_{CSx} = \frac{DCR}{R_G} \cdot \frac{1 + s \cdot L / DCR}{1 + s \cdot R \cdot C} \cdot I_{PHASEx}$$

Considering now to match the time constant between the inductor and the R-C filter applied (Time constant mismatches cause the introduction of poles into the current reading network causing instability. In addition, it is also important for the load transient response and to let the system show resistive equivalent output impedance) it results:

$$\frac{L}{R_L} = R \cdot C \Rightarrow I_{CSxN} = \frac{R_L}{R_G} \cdot I_{PHASEx} = I_{INFOx}$$

R_G resistor is typical designed in order to have an information current I_{INFOx} in the range of $35\mu A$ at the OC Threshold.

The current read through the CSx / CSxN pairs is converted into a current I_{INFOx} proportional to the current delivered by each phase and the information about the average current $I_{AVG} = \Sigma I_{INFOx} / N$ is internally built into the device (N is the number of working phases). The error between the read current I_{INFOx} and the reference I_{AVG} is then converted into a voltage that with a proper gain is used to adjust the duty cycle whose dominant value is set by the voltage error amplifier in order to equalize the current carried by each phase.

Figure 7. Current reading connections

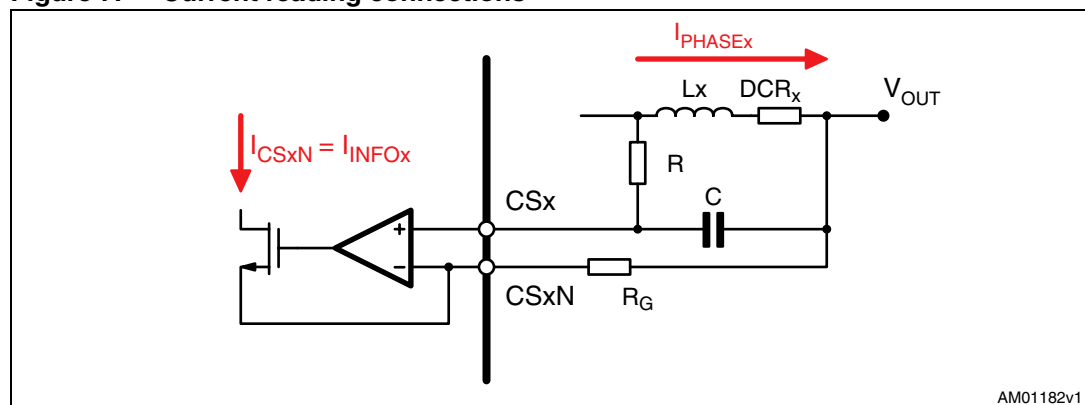

5.3 Output voltage load-line definition

L6756D is able to introduce a dependence of the output voltage on the load current recovering part of the drop due to the output capacitor ESR in the load transient. Introducing a dependence of the output voltage on the load current, a static error, proportional to the output current, causes the output voltage to vary according to the sensed current.

Figure 7 shows the current sense circuit used to implement the load-line. The current flowing across the inductor(s) is read through the R - C filter across CSx and CSxN pins. R_G programs a transconductance gain and generates a current I_{CSx} proportional to the current of the phase x. The sum of the I_{CSx} current is then sourced by the VFB pin (I_{DROOP}). R_{FB} gives the final gain to program the desired load-line slope (*Figure 6*).

Time constant matching between the inductor (L / DCR) and the current reading filter (RC) is required to implement a real equivalent output impedance of the system so avoiding over and/or under shoot of the output voltage as a consequence of a load transient. The output characteristic vs. load current is then given by (Offset disabled):

$$V_{OUT} = VID - R_{FB} \cdot I_{DROOP} = VID - R_{FB} \cdot \frac{DCR}{R_G} \cdot I_{OUT} = VID - R_{LL} \cdot I_{OUT}$$

Where R_{LL} is the resulting load-line resistance implemented by the controller. The whole power supply can be then represented by a “real” voltage generator with an equivalent output resistance R_{LL} and a voltage value of VID.

R_{FB} resistor can be then designed according to the R_{LL} specifications as follow:

$$R_{FB} = R_{LL} \cdot \frac{R_G}{DCR}$$

Note: Load-Line (DROOP) implementation is optional, in case it is not desired, the resulting current information available on VDRP may be employed for other purposes, such as an additional Load Indicator (LI2). In this case, simply connect a resistor R_{LI2} to SGND: the resulting voltage drop across R_{LI2} will be proportional to the delivered current according to the following relationship:

$$V_{LI2} = R_{LI2} \cdot \frac{DCR}{R_G} \cdot I_{OUT}$$

In case no additional information about the delivered current is requested, the VDRP pin can be shorted to SGND.

5.4 Output voltage offset

The current (I_{OS}) sunk from the VSEN pin allows programming a positive offset (V_{OS}) for the output voltage by connecting a resistor R_{OS} to V_{OUT} in series to the FB loop. The sunk current generates a voltage drop according to the connected R_{OS} . Output voltage is then programmed as follow:

$$V_{CORE} = VID - (R_{FB} + R_{OS}) \cdot I_{DROOP} + R_{OS} \cdot I_{OS}$$

Caution: Offset resistor impacts the voltage positioning! It need to be considered in series to R_{FB} .

Note: Offset implementation is optional: in case it is not desired, simply consider using $R_{OS} = 0 \Omega$

5.5 Dynamic VID transitions

L6756D manages dynamic VID transitions that allow the output voltage to modify during normal device operation for CPU power management purposes. OV and UV signals are properly masked during every DVID Transition and they are re-activated with a 16 clock cycle delay to prevent from false triggering.

When changing dynamically the regulated voltage (DVID), the system needs to charge or discharge the output capacitor accordingly. This means that an extra-current I_{DVID} needs to be delivered (especially when increasing the output regulated voltage) and it must be considered when setting the over current threshold of both the sections. This current results:

$$I_{DVID} = C_{OUT} \cdot \frac{dV_{OUT}}{dT_{VID}}$$

where dV_{OUT} / dT_{VID} depends on the operative mode (typically externally driven).

Dynamic VID transition is managed by checking for VID code modifications (See [Figure 8](#)) on the rising edge of an internal additional DVID-clock and waiting for a confirmation on the following falling edge. Once the new code is stable, on the next rising edge, the reference starts stepping up or down in LSB increments every two DVID-clock cycle until the new VID code is reached.

DVID-clock frequency (F_{DVID}) is 1 MHz (Typ).

Caution: Overcoming the OC threshold during the DVID causes the device latch and disable.

Caution: If the new VID code is more than 1 LSB different from the previous, the device will execute the transition stepping the reference with the DVID-clock frequency F_{DVID} until the new code has reached. The output voltage rate of change will be of [LSB]mV * F_{DVID} !

Figure 8. DVID transitions

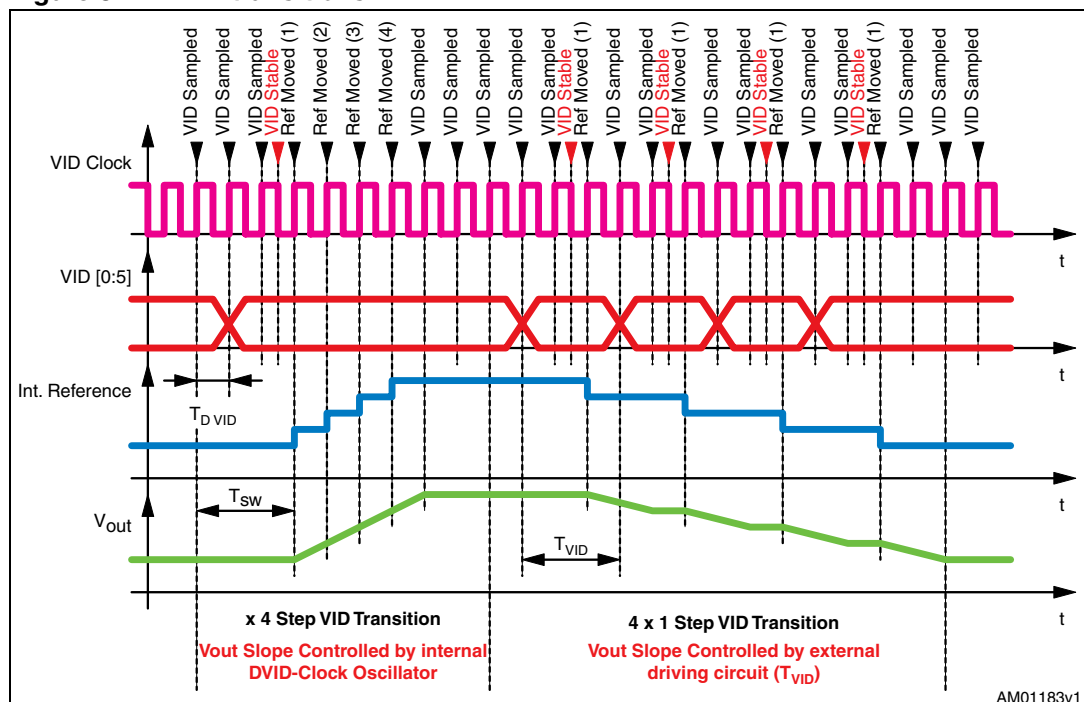

5.6 Soft-start

L6756D implements a soft-start to smoothly charge the output filter avoiding high in-rush currents to be required to the input power supply. During this phase, the device increases the reference from zero up to the programmed reference in closed loop regulation. Soft-start is implemented only when all the power supplies are above their own turn-on thresholds and the EN pin is set free. At the end of the digital soft-start, VR_RDY signal is set free.

Soft-start phase is initiated with a $T_1 = 2 \text{ ms}$ (min) delay. After that, the reference ramps up to $V_{BOOT} = 1.081 \text{ V}$ in T_2 according to the R_{SS} settings and waits for $T_3 = 200 \text{ }\mu\text{sec}$ (typ) during which the device reads the VID lines. Output voltage will then ramps up to the programmed value in T_4 with the same slope as before (See [Figure 9](#)).

SS sets the output voltage dv/dt during soft-start according to the resistor R_{SS} connected to SGND. soft-start time T_{SS} will proportionally change with a gain of $18.52 \text{ }[\mu\text{s} / \text{k}\Omega]$. Connect $27 \text{ k}\Omega$ resistor to program $T_2 = 500 \text{ }\mu\text{s}$.

Protections are active during soft-start, UVP is enabled after the reference reaches 0.5 V while OVP is always active with a fixed 1.24 V threshold before V_{BOOT} and with the threshold coming from the VID after V_{BOOT} (See red-dashed line in [Figure 9](#)).

Note: If during T_3 the programmed VID selects an output voltage lower than V_{BOOT} , the output voltage will ramp to the programmed voltage starting from V_{BOOT} .

Note: The VID code is checked at the end of T_3 . In case the device is enabled over an OFF code, the output voltage will rise up to V_{BOOT} and then device will latch. VID lines does not show any pull-up and/or pull-down before T_3 .

Figure 9. Soft-start timings

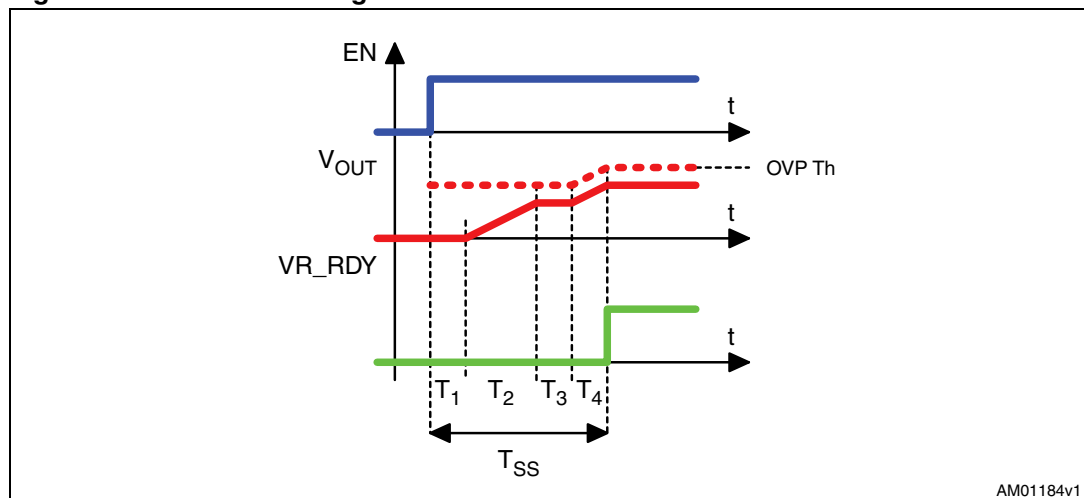

5.6.1 LSLESS start-up

In order to avoid any kind of negative undershoot on the load side during start-up, L6756D performs a special sequence in enabling the drivers for both sections: during the soft-start phase, the LS driver results to be disabled (LS = OFF - Gx set to HiZ and DRVON = 0) until the first PWM pulse. After the first PWM pulse, Gx outputs switches between logic "0" and logic "1" and DRVON is set to logic "1".

This particular sequence avoids the dangerous negative spike on the output voltage that can happen if starting over a pre-biased output.

Low-side MOSFET turn-on is masked only from the control loop point of view: protections are still allowed to turn-ON the low-side MOSFET in case of overvoltage if needed.

Figure 10. LSLESS start-up: enabled (left) and disabled (right)

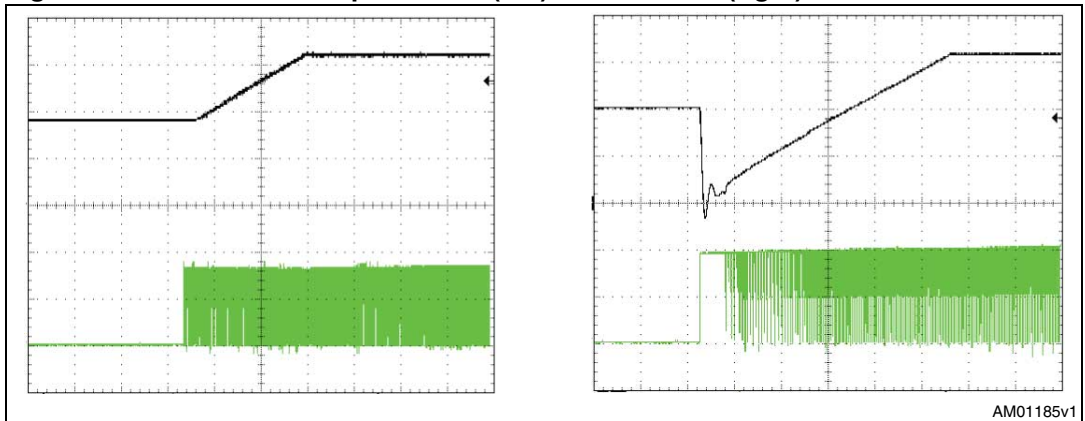

6 Output voltage monitoring and protections

L6756D monitors through pin VSEN the regulated voltage in order to manage OV and UV. The device shows different thresholds when in different operative conditions but the behavior in response to a protection event is still the same as described below.

6.1 Overvoltage

Once VCC crosses the turn-ON threshold and the device is enabled (EN = 1), L6756D provides an overvoltage protection by sensing the regulated voltage through VSEN: when it overcomes the programmed VID +200 mV (max) the controller:

- Permanently sets Gx to zero keeping DRVON high in order to keep all the low-side MOSFETs on to protect the load.
- Drives the OSC/ FLT pin high.
- Power supply or EN pin cycling is required to restart operations.

6.2 Feedback disconnection

This feature acts in order to stop the device from regulating dangerous voltages in case the remote sense connections are left floating. The protection is available for both the positive and negative sense.

According to what reported in [Figure 11](#), the protection works as follow:

- Positive sense consider to monitor the CORE output voltage through both VSEN and CSxN. As soon as CSxN is more than 650 mV higher than VSEN, the device latches with all Gx set to HiZ and DRVON set to zero. FLT pin is driven high. In any case, the 50 μ A pull-down current on the VSEN (offset) forces the device to detect the fault condition.
- Negative sense consider to monitor the internal opamp used to recover the SGND losses by comparing its output and the internal reference generated by the DAC. As soon as the difference between the output and the input of this opamp is higher than 500mV, the device latches with all Gx set to HiZ and DRVON set to zero. FLT pin is driven high.
- To recover from a latch condition, cycle VCC or EN.

Figure 11. FB disconnection protection

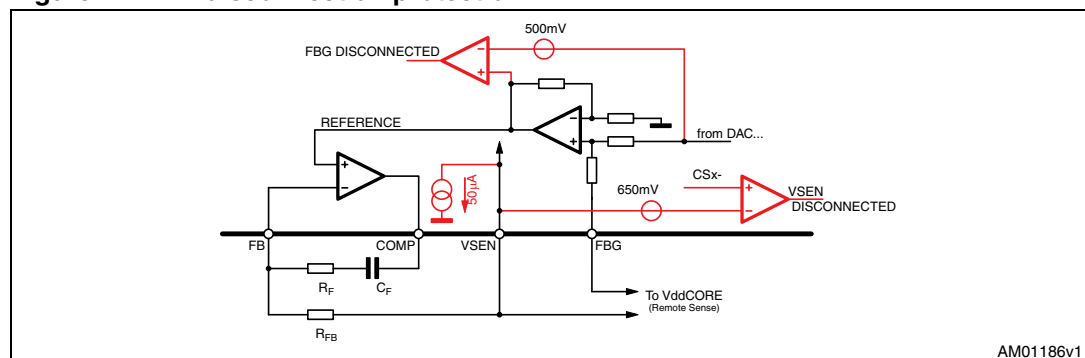

6.3 VR_RDY

It is an open-drain signal set free after the soft-start sequence has finished.

6.4 Over current

The over current threshold has to be programmed to a safe value, in order to be sure that the system doesn't enter OC during normal operation. This value must take into consideration also the extra current needed during the DVID transition (I_{DVID}) and the process spread and temperature variations of the sensing elements (inductor DCR).

Moreover, since also the internal threshold spreads, the design has to consider the minimum/maximum value of the thresholds.

L6756D monitors the average current and allows to set the OC threshold by programming R_{ILIM} . ILIM pin allows to define a maximum average output current for the system (I_{MAX}). A copy of the DROOP current is sourced from the ILIM pin. By connecting a resistor R_{ILIM} to SGND, a load indicator with 1.7 V (V_{OC}) end-of-scale can be implemented. This means that when the voltage present at the ILIM pin crosses 1.7 V, the device detects an OC and immediately latches with all the mosfets OFF (HiZ).

Typical design flow is the following:

- Define the maximum average output current (I_{MAX}) according to system requirements
- Design R_G resistor in order to have $I_{INFOX} = 35 \mu A$ when I_{OUT} is about 10 % higher than the I_{MAX} current. It results:

$$R_G = \frac{(1.1 \cdot I_{MAX}) \cdot DCR}{N \cdot I_{OCTH}}$$

where N is the number of phases and DCR the DC resistance of the inductors. R_G design must be typically performed in worst-case conditions.

- Design R_{ILIM} in order to have the ILIM pin to V_{OC} at the desired I_{MAX} current. It results:

$$R_{ILIM} = \frac{V_{OCAVG} \cdot R_G}{I_{MAX} \cdot DCR} = \frac{1.7V \cdot R_G}{I_{MAX} \cdot DCR}$$

where I_{MAX} is the OC threshold desired.

- Adjust the defined values according to bench-test of the application.

Note: OC intervention can be delayed by adding a capacitor in parallel to the above defined R_{ILIM} .

7 Low power-state management and PSI#

PSI# is an active-low input that can be set by the CPU to allow the regulator to enter power-saving mode to maximize the system efficiency when in light-load conditions. The controller constantly monitors the PSI_A pin to define the PSI strategy, that is the action performed by the controller when PSI# is asserted. According to [Table 9](#), by programming different voltages on PSI_A, it is possible to configure the device to work at one or two phases while PSI# is asserted. The device can also be configured to take no action so phase number will not change after PSI# assertion.

In case the phase number is changed, the device will disable one or more phases by setting in HiZ the relative PWM and re-configuring the internal phase-shift to maintain the interleaving. Furthermore, the internal current-sharing will be adjusted to consider the phase number reduction. ENDRV will remain asserted.

When PSI# is de-asserted, the device will return to the original configuration.

Start-up is performed with all the configured phases enabled. In case of DVID transitions, the device will use all the phases available to perform the transition coming back to the PSI reduced number of phases after the transition has.

PSI Strategy is continuously monitored across PSI_A pin.

Caution: When PSI_A is set for working at 2phases when PSI# is asserted, the IC will work as if configured for 2phases so enabling only Phase1 and Phase3.

Table 9. PSI strategy

PSI_A	PSI Strategy	PSI#/VR10
GND / Open	No strategy. IC will work in VR11 mode	VR10
100 kΩ to VREF	Phase number set to 2 while PSI# is asserted (only phase1 and Phase3 are active).	PSI#
to VREF	Phase number set to 1 while PSI# is asserted (only phase1 is active).	

Figure 12. System efficiency enhancement by PSI#

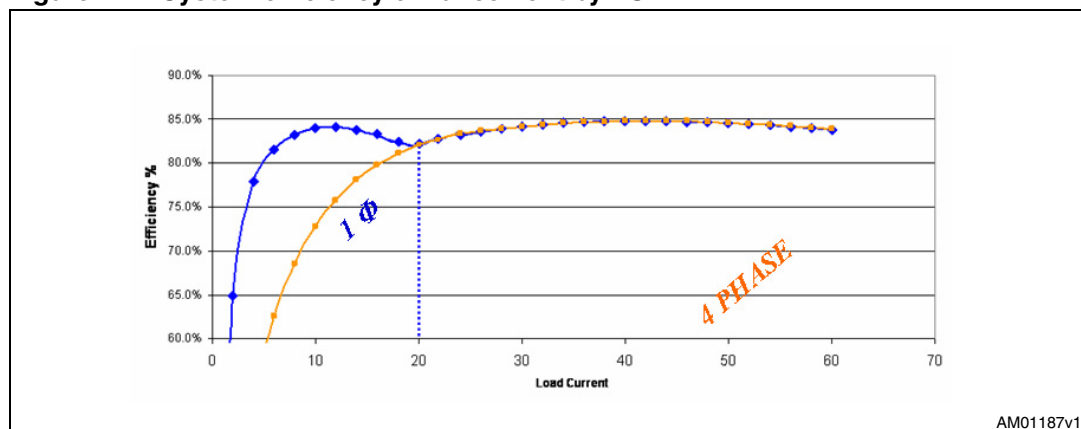

8 Main oscillator

The internal oscillator generates the triangular waveform for the PWM charging and discharging with a constant current an internal capacitor. The switching frequency for each channel, F_{SW} , is internally fixed at 200 kHz: the resulting switching frequency at the load side results in being multiplied by N (number of configured phases).

The current delivered to the oscillator may be varied using an external resistor (R_{OSC}) typically connected between the OSC pin and SGND. Since the OSC pin is fixed at 1.24 V, the frequency is varied proportionally to the current sunk from the pin considering the internal gain of 10 kHz/ μ A (See [Figure 13](#)).

Connecting R_{OSC} to SGND the frequency is increased (current is sunk from the pin), according to the following relationships:

$$F_{SW} = 200\text{kHz} + \frac{1.240\text{V}}{R_{OSC}(\text{k}\Omega)} \cdot 10 \frac{\text{kHz}}{\mu\text{A}}$$

Figure 13. R_{OSC} vs. switching frequency per phase

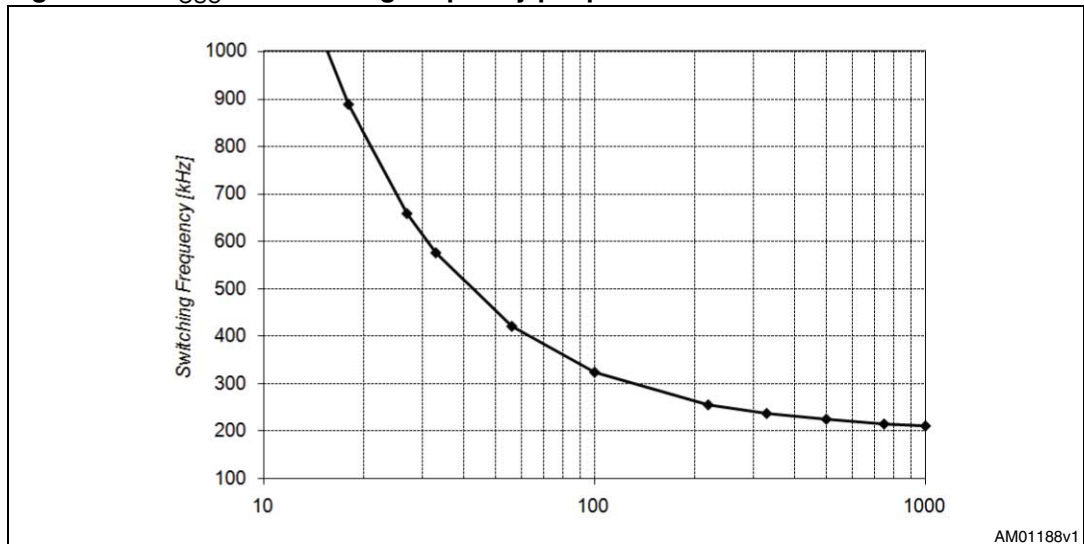

9 System control loop compensation

The control system can be modeled with an equivalent single-phase converter which only difference is the equivalent inductor L/N (where each phase has an L inductor and N is the number of the configured phases). See [Figure 14](#).

Figure 14. Equivalent control loop

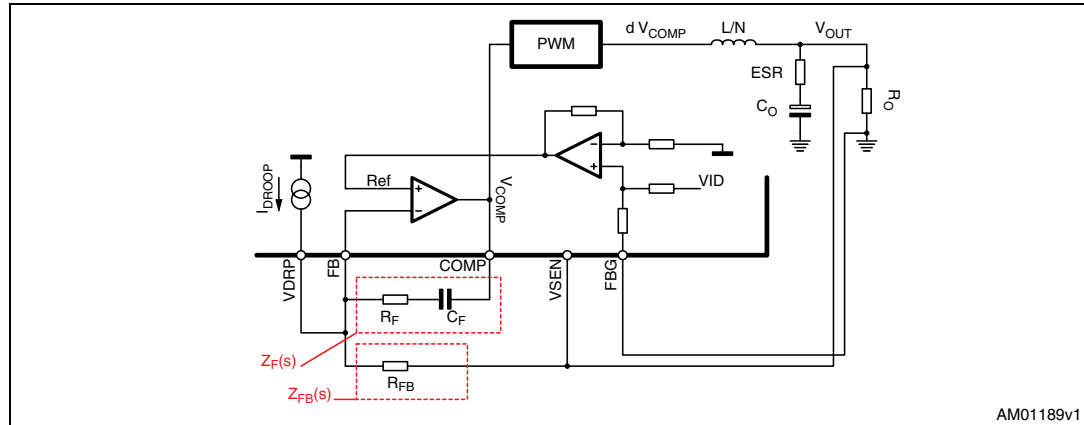

The control loop gain results (obtained opening the loop after the COMP pin):

$$G_{\text{LOOP}}(s) = \frac{\text{PWM} \cdot Z_F(s) \cdot (R_{\text{LL}} + Z_P(s))}{[Z_P(s) + Z_L(s)] \cdot \left[\frac{Z_F(s)}{A(s)} + \left(1 + \frac{1}{A(s)} \right) \cdot R_{\text{FB}} \right]}$$

Where:

- R_{LL} is the equivalent output resistance determined by the droop function (Voltage positioning);
- $Z_P(s)$ is the impedance resulting by the parallel of the output capacitor (and its ESR) and the applied load R_O ;
- $Z_F(s)$ is the compensation network impedance;
- $Z_L(s)$ is the equivalent inductor impedance;
- $A(s)$ is the error amplifier gain;
- $\text{PWM} = \frac{6}{10} \cdot \frac{V_{\text{IN}}}{\Delta V_{\text{OSC}}}$ is the PWM transfer function.

The Control Loop gain is designed in order to obtain a high DC gain to minimize static error and to cross the 0 dB axes with a constant -20 dB/dec slope with the desired crossover frequency ω_T . Neglecting the effect of $Z_F(s)$, the transfer function has one zero and two poles; both the poles are fixed once the output filter is designed (LC filter resonance ω_{LC}) and the zero (ω_{ESR}) is fixed by ESR and the droop resistance.

Figure 15. Control loop bode diagram and fine tuning

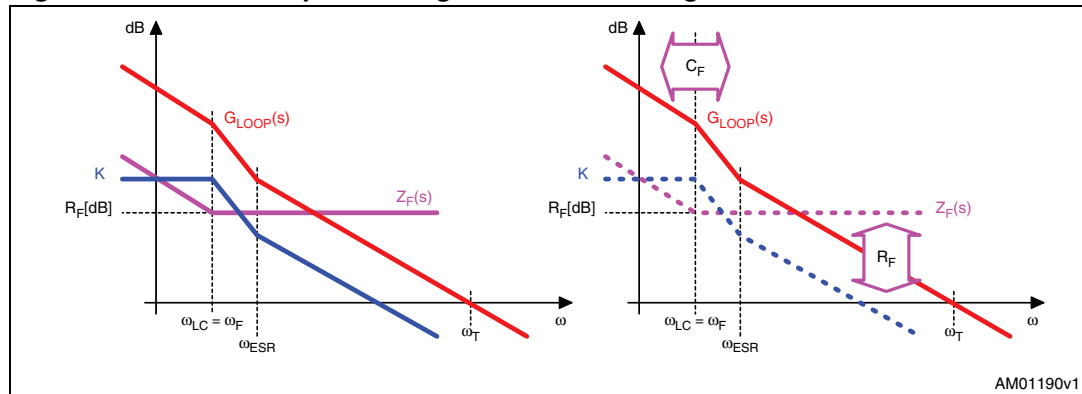

To obtain the desired shape an R_F - C_F series network is considered for the $Z_F(s)$ implementation. A zero at $\omega_F = 1/R_F C_F$ is then introduced together with an integrator. This integrator minimizes the static error while placing the zero ω_F in correspondence with the L-C resonance assures a simple -20 dB/dec shape of the gain.

In fact, considering the usual value for the output filter, the LC resonance results to be at frequency lower than the above reported zero.

Compensation network can be simply designed placing $\omega_F = \omega_{LC}$ and imposing the cross-over frequency ω_T as desired obtaining (always considering that ω_T might be not higher than 1/10 th of the switching frequency F_{SW}):

$$R_F = \frac{R_{FB} \cdot \Delta V_{OSC}}{V_{IN}} \cdot \frac{10}{6} \cdot \omega_T \cdot \frac{L}{N \cdot (R_{LL} + ESR)}$$

$$C_F = \frac{\sqrt{C_O \cdot L}}{R_F}$$

9.1 Compensation network guidelines

The compensation network design assures to having system response according to the cross-over frequency selected and to the output filter considered: it is anyway possible to further fine-tune the compensation network modifying the bandwidth in order to get the best response of the system as follow (See [Figure 15](#)):

- Increase R_F to increase the system bandwidth accordingly;
- Decrease R_F to decrease the system bandwidth accordingly;
- Increase C_F to move ω_F to low frequencies increasing as a consequence the system phase margin.

Having the fastest compensation network gives not the confidence to satisfy the requirements of the load: the inductor still limits the maximum di/dt that the system can afford. In fact, when a load transient is applied, the best that the controller can do is to “saturate” the duty cycle to its maximum (d_{MAX}) or minimum (0) value. The output voltage dV/dt is then limited by the inductor charge / discharge time and by the output capacitance. In particular, the most limiting transition corresponds to the load-removal since the inductor results being discharged only by V_{OUT} (while it is charged by $V_{IN} - V_{OUT}$ during a load appliance).

Sensitivity of the load transient detector and the gain of the LTB ramp can be programmed in order to control precisely both the undershoot and the ring-back.

- *Detector design.* R_{LTB} - C_{LTB} is design according to the output voltage deviation dV_{OUT} which is desired the controller to be sensitive as follow:

$$R_{LTB} = \frac{dV_{OUT}}{25\mu A} \quad C_{LTB} = \frac{1}{2\pi N \cdot R_{LTB} \cdot F_{SW}}$$

- *Gain design.* Through the LTBGAIN pin it is possible to modify the slope of the LTB Ramp in order to modulate the entity of the LTB response once the LT has been detected. In fact, the response depends on the board design and its parasites requiring different actions from the controller.

Leaving the LTBGAIN pin floating, the maximum pulse-width is programmed. The slope of the LTB ramp will be equal to 1/2 of the OSC ramp slope.

Connecting $R_{LTBGAIN}$ to GND, the LTB Ramp slope can be modified as follow:

$$LTBRamp_{Slope} = OSC_{Slope} \cdot \left(1 + \frac{I_{LTBGAIN}}{I_{OSC}} \right)$$

Where $I_{LTBGAIN}$ is the current sunk from LTBGAIN pin and I_{OSC} is the OSC current (20 μ A plus the current coming from the OSC pin).

LTB Technology[®] design tips.

- Descries R_{LTB} to increase the system sensitivity making the system sensitive to smaller dV_{OUT} .
- Increase C_{LTB} to increase the system sensitivity making the system sensitive to higher dV/dt .
- Increase $R_{LTBGAIN}$ to increase the width of the LTB pulse.

10 Mechanical data and package dimensions

In order to meet environmental requirements, ST offers these devices in ECOPACK® packages. These packages have a lead-free second level interconnect. The category of second Level Interconnect is marked on the package and on the inner box label, in compliance with JEDEC Standard JESD97. The maximum ratings related to soldering conditions are also marked on the inner box label. ECOPACK is an ST trademark. ECOPACK specifications are available at: www.st.com.

Figure 17. Mechanical data and package dimensions

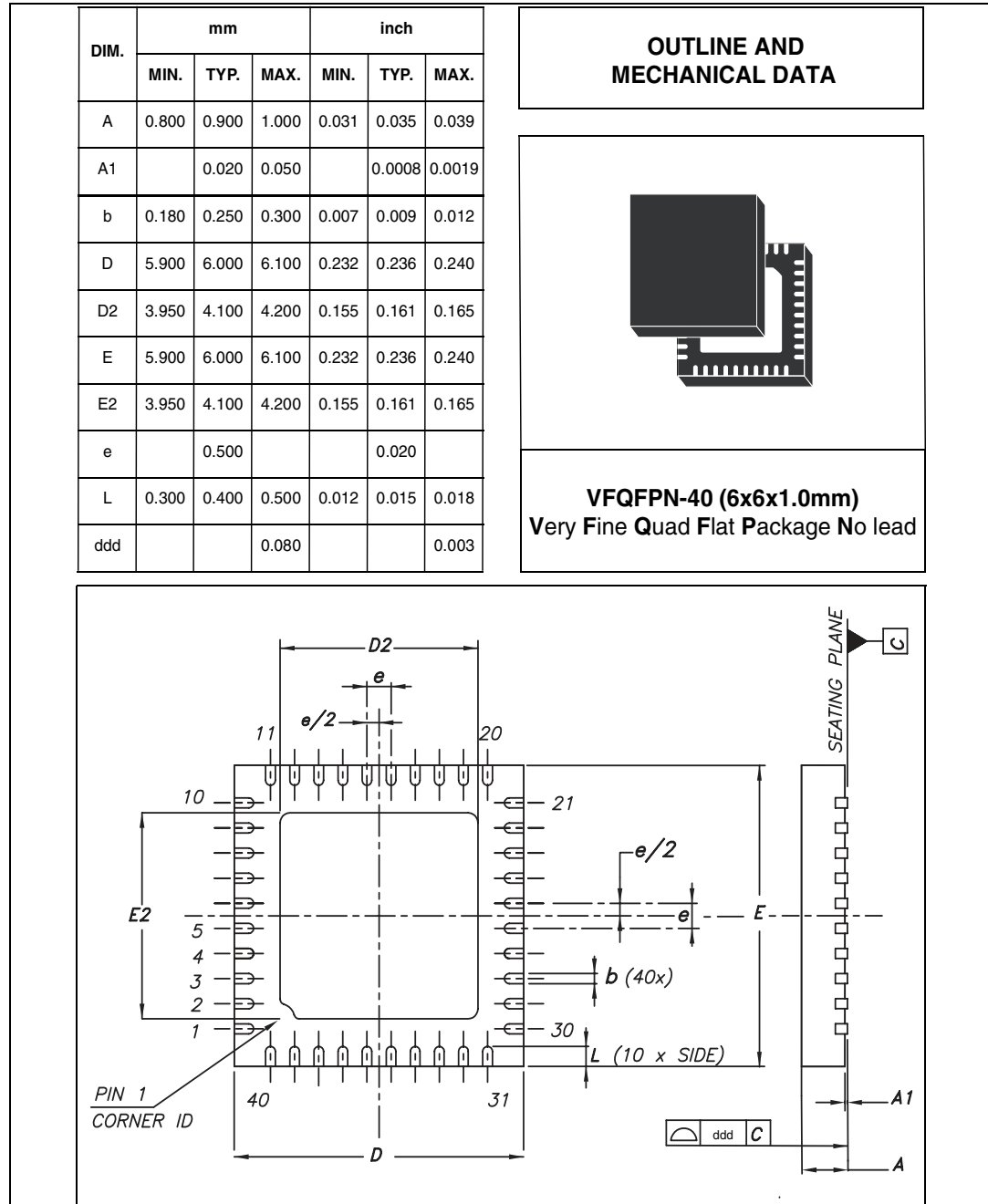

11 Revision history

Table 10. Document revision history

Date	Revision	Changes
01-Oct-2008	1	Initial release

Please Read Carefully:

Information in this document is provided solely in connection with ST products. STMicroelectronics NV and its subsidiaries ("ST") reserve the right to make changes, corrections, modifications or improvements, to this document, and the products and services described herein at any time, without notice.

All ST products are sold pursuant to ST's terms and conditions of sale.

Purchasers are solely responsible for the choice, selection and use of the ST products and services described herein, and ST assumes no liability whatsoever relating to the choice, selection or use of the ST products and services described herein.

No license, express or implied, by estoppel or otherwise, to any intellectual property rights is granted under this document. If any part of this document refers to any third party products or services it shall not be deemed a license grant by ST for the use of such third party products or services, or any intellectual property contained therein or considered as a warranty covering the use in any manner whatsoever of such third party products or services or any intellectual property contained therein.

UNLESS OTHERWISE SET FORTH IN ST'S TERMS AND CONDITIONS OF SALE ST DISCLAIMS ANY EXPRESS OR IMPLIED WARRANTY WITH RESPECT TO THE USE AND/OR SALE OF ST PRODUCTS INCLUDING WITHOUT LIMITATION IMPLIED WARRANTIES OF MERCHANTABILITY, FITNESS FOR A PARTICULAR PURPOSE (AND THEIR EQUIVALENTS UNDER THE LAWS OF ANY JURISDICTION), OR INFRINGEMENT OF ANY PATENT, COPYRIGHT OR OTHER INTELLECTUAL PROPERTY RIGHT.

UNLESS EXPRESSLY APPROVED IN WRITING BY AN AUTHORIZED ST REPRESENTATIVE, ST PRODUCTS ARE NOT RECOMMENDED, AUTHORIZED OR WARRANTED FOR USE IN MILITARY, AIR CRAFT, SPACE, LIFE SAVING, OR LIFE SUSTAINING APPLICATIONS, NOR IN PRODUCTS OR SYSTEMS WHERE FAILURE OR MALFUNCTION MAY RESULT IN PERSONAL INJURY, DEATH, OR SEVERE PROPERTY OR ENVIRONMENTAL DAMAGE. ST PRODUCTS WHICH ARE NOT SPECIFIED AS "AUTOMOTIVE GRADE" MAY ONLY BE USED IN AUTOMOTIVE APPLICATIONS AT USER'S OWN RISK.

Resale of ST products with provisions different from the statements and/or technical features set forth in this document shall immediately void any warranty granted by ST for the ST product or service described herein and shall not create or extend in any manner whatsoever, any liability of ST.

ST and the ST logo are trademarks or registered trademarks of ST in various countries.

Information in this document supersedes and replaces all information previously supplied.

The ST logo is a registered trademark of STMicroelectronics. All other names are the property of their respective owners.

© 2008 STMicroelectronics - All rights reserved

STMicroelectronics group of companies

Australia - Belgium - Brazil - Canada - China - Czech Republic - Finland - France - Germany - Hong Kong - India - Israel - Italy - Japan - Malaysia - Malta - Morocco - Singapore - Spain - Sweden - Switzerland - United Kingdom - United States of America

www.st.com