

REVISION		
REV	DESCRIPTION	DATE
E	REVISED PER DCR NUMBER T31569	6/12/03

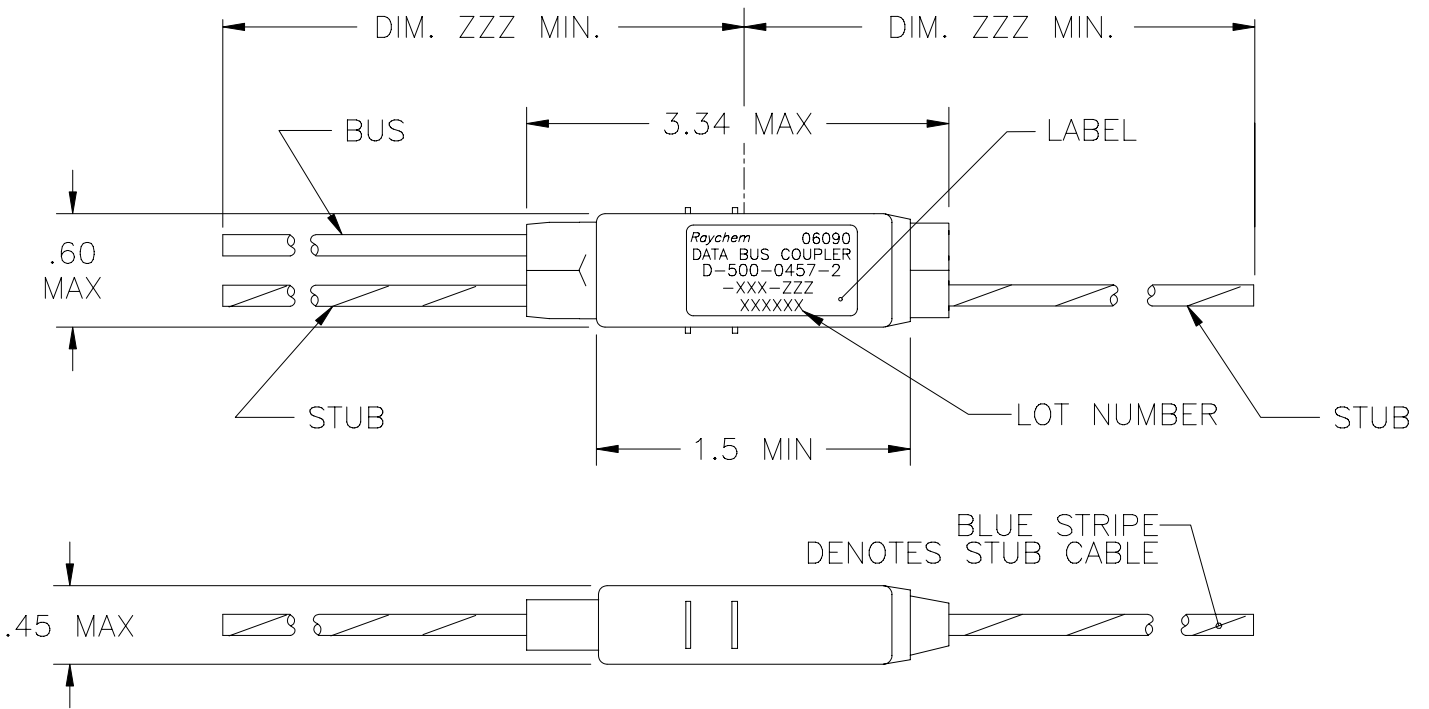

COMPONENT NUMBER	BUS CABLE	STUB CABLE
D-500-0457-2-612-ZZZ	10612-24-9	10612-24-96
D-500-0457-2-613-ZZZ	10613-24-9	10613-24-96
D-500-0457-2-614-ZZZ	10614-24-9	10614-24-96

PART NO. D-500-0457-2-XXX-ZZZ

SCHEMATIC  
7=TERMINATOR (AS SHOWN)

LENGTH OF CABLE (INCHES)

2=DOUBLE STUB

CABLE  
612=10612  
613=10613  
614=10614

If this document is printed it becomes uncontrolled.  
Check for the latest revision.

UNLESS OTHERWISE SPECIFIED DIMENSIONS ARE INCHES. METRIC DIMENSIONS ARE IN BRACKETS.

DECIMAL TOLERANCES  
.XXX ± --- [ --- mm]  
.XX ± --- [ --- mm]  
.X ± --- [ --- mm]

ANGLE TOLERANCE  
.X ± ---

WEIGHT  
SEE NOTES

DRAWN  
D.PIQUE

DATE  
95MAY11

MATERIAL

FINISH

THIRD ANGLE PROJECTION

SPECIFICATION CONTROL DRAWING

**tyco**  
**Electronics**

Tyco Electronics  
300 CONSTITUTION DRIVE  
MENLO PARK, CALIFORNIA 94025 USA

Raychem

TITLE  
DATABUS MICROCOUPLER  
TWO STUB IN-LINE, 04 SERIES  
WITH BUS TERMINATOR

SIZE  
A

CODE IDENT. NO.  
06090

DWG. NO.  
D-500-0457-2-XXX-ZZZ

CAD FILE  
T31569A

DO NOT SCALE THIS DRAWING

SHEET 1 OF 2

1. MATERIAL AND FINISHES:

1.1 INTERNAL COMPONENTS:

1.1.1 -TRANSFORMER TO MIL-PRF-21038 AND MIL-STD-1553B

1.1.2 -RESISTORS, ISOLATION PER MIL-PRF-39007/9, 57.6 OHMS (R1)

1.1.3 -RESISTOR, TERMINATION PER MIL-PRF-39007/9, 76.8 OHMS (R2)

1.2 SHIELDED CASE: ALUMINUM PER ASTM-B618

1.3 SEALED STRAIN RELIEF COVER: MODIFIED CROSS-LINKED ELASTOMER, BLACK, TO RAYCHEM SPECIFICATION RK-6713.

1.4 CABLE TYPE PER RAYCHEM SPECIFICATION 1200 (SEE PART NO. ON SHEET 1).

2. APPLICATION:

2.1 THIS COUPLER IS DESIGNED TO BE INSTALLED INTO A DIGITAL MULTIPLEX ASSEMBLY MEETING THE REQUIREMENTS OF MIL-STD-1553B.

2.2 FOR CABLE SPLICING USE FLEXIBLE SPLICE KIT D-150-0708-5 (NOT SUPPLIED)

2.3 CABLE BEND RADIUS PER SAE-AS50881 STATIC BEND: 5 x CABLE O.D. MIN.  
DYNAMIC BEND: 10 x CABLE O.D. MIN.

3. TEMPERATURE:

3.1 OPERATING TEMPERATURE: -65°C TO +150°C

4. PERFORMANCE SPECIFICATIONS:

4.1 TRANSFORMER MEETS THE PERFORMANCE REQUIREMENTS OF MIL-STD-1553B.

4.2 COUPLER MEETS THE PERFORMANCE REQUIREMENTS OF RAYCHEM SPECIFICATION D-6020.

5. WEIGHT:

5.1 MAXIMUM WEIGHT WITHOUT CABLE: 15 GRAMS MAX.

TWO STUB COUPLER SCHEMATIC

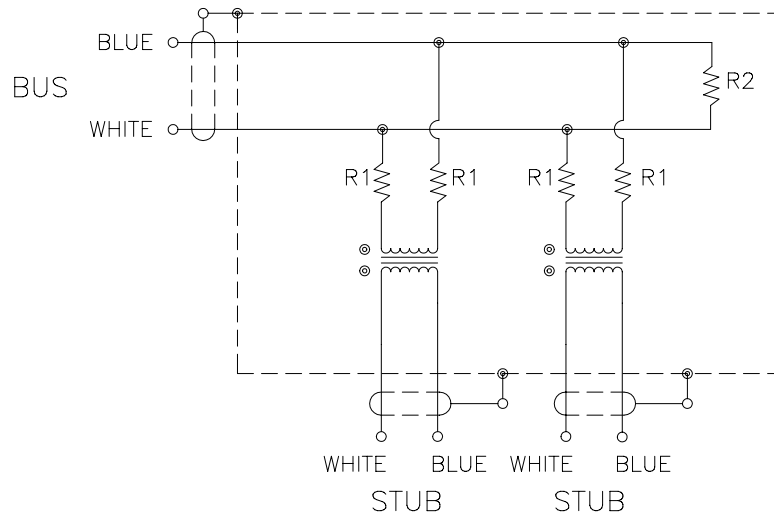

If this document is printed it becomes uncontrolled.  
Check for the latest revision.

SPECIFICATION CONTROL DRAWING

DRAWN DCP	DATE 95MAY11	SIZE A	CODE IDENT. NO. 06090	DWG. NO. D-500-0457-2-XXX-ZZZ	REV E
CAD FILE T31569B	<b>tyco</b> <b>Electronics</b>	DO NOT SCALE THIS DRAWING			SHEET 2 OF 2