

MATERIAL NO.	ENGINEERING NO.
1300190023	43305

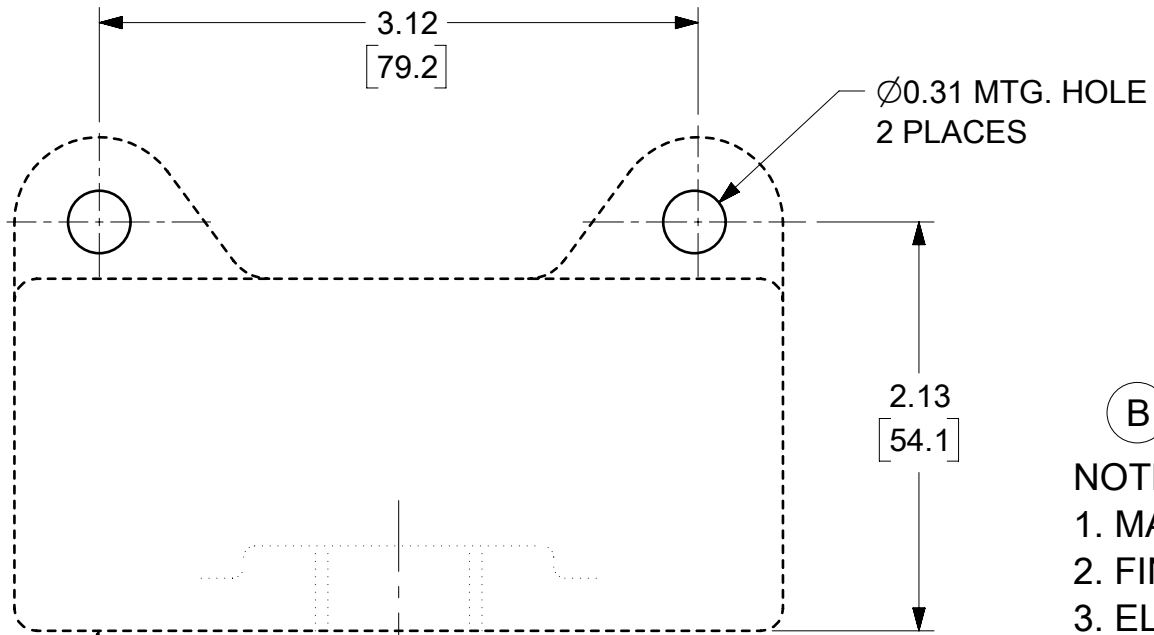
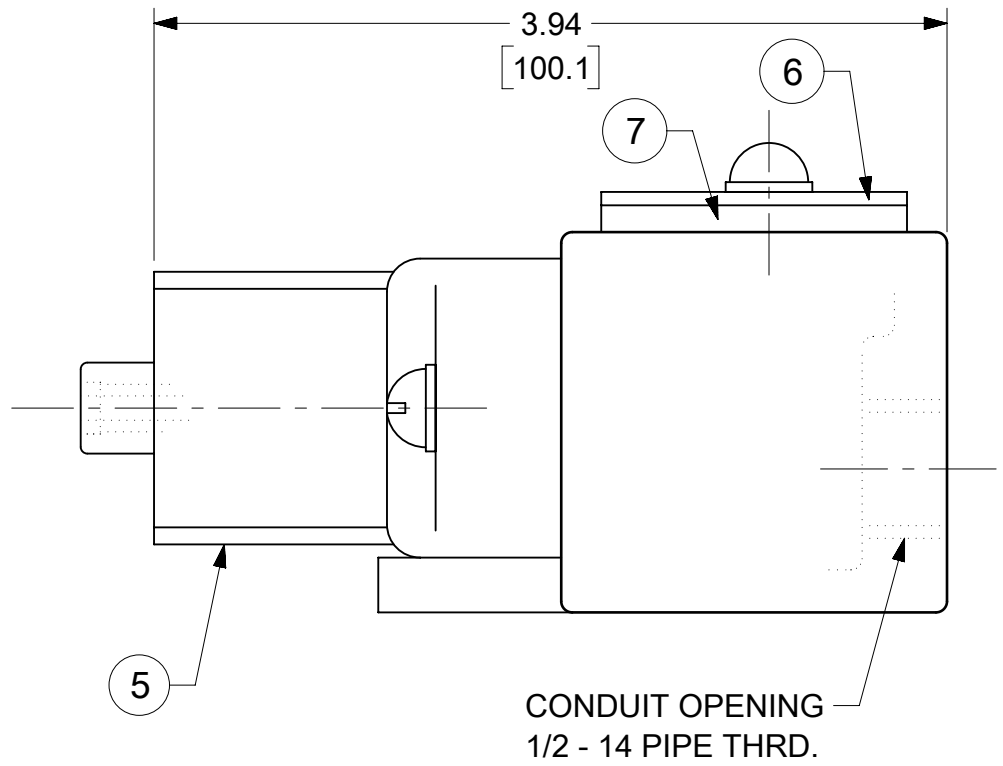
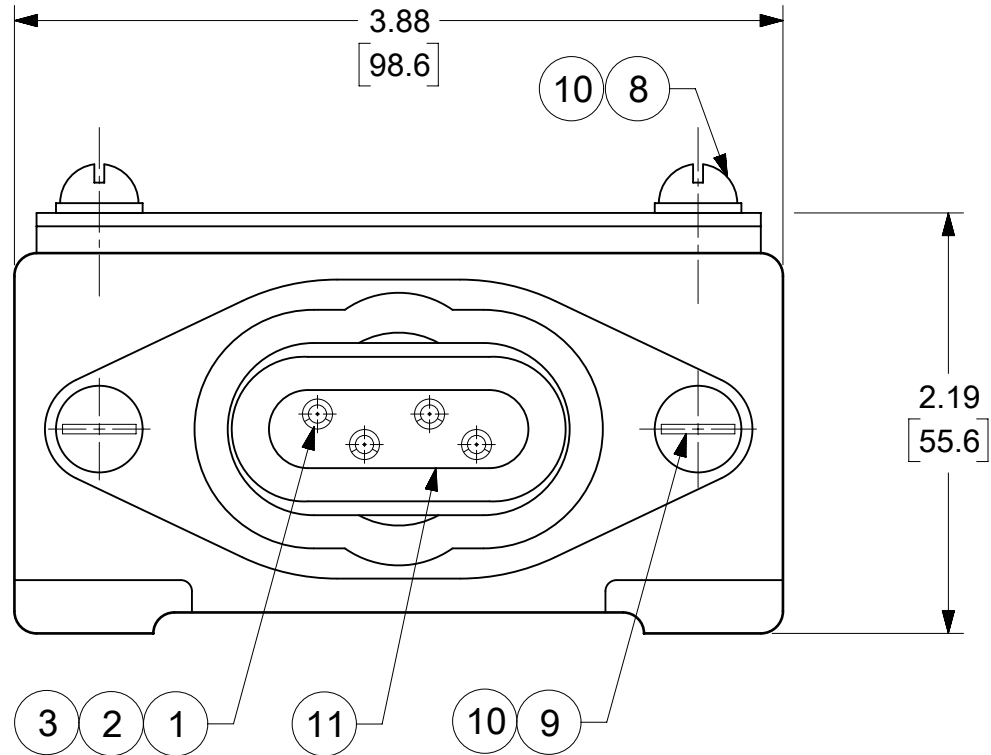

MOUNTING PLAN

- (B)**
NOTES:
 1. MATERIAL: AS NOTED
 2. FINISH: AS NOTED
 3. ELECTRICAL:
 VOLTAGE: 600VAC
 CURRENT: 25A
 4. TEMP RATING: -20°C TO +90°C
 5. CSA CERTIFIED FILE: LR6837
 6. UL RECOGNIZED FILE: E46237
 7. ALL DIMS ARE FOR REFERENCE UNLESS TOLERANCED OR NOTED OTHERWISE

11	OVERMOLD	RUBBER	ORANGE
10	LOCKWASHER	STEEL	ZINC PLATED
9	SCREW, 1/4-20 X 1.00"-ROUND HEAD	STEEL	ZINC PLATED
8	SCREW, 1/4-20 X 3/8"-ROUND HEAD	STEEL	ZINC PLATED
7	GASKET	NEOPRENE	
6	PLATE	ALUMINUM	
5	MOUNTING SHELL	ALUMINUM	
4	MOUNTING BASE	ALUMINUM	
3	#6-32 SCREW	Cu ALLOY	ZINC PLATED
2	FLAT WASHER	FIBRE	
1	SOCKET ASSEMBLY	Cu ALLOY	
ITEM	DESCRIPTION	MATERIAL	FINISH

FUNCTIONAL SYMBOLS				THIS DRAWING CONTAINS INFORMATION THAT IS PROPRIETARY TO MOLEX ELECTRONIC TECHNOLOGIES, LLC AND SHOULD NOT BE USED WITHOUT WRITTEN PERMISSION			
DIMENSION UNITS		SCALE		CURRENT REV DESC: ADDED NOTES			
INCH/MM		1:1		<p>molex</p> <p>DIE BLOCK-CAST RECEIPT. FEMALE STATIONARY CONN. 4 POLE ORANGE</p> <p>PRODUCT CUSTOMER DRAWING</p> <p>DOCUMENT NUMBER: SD-130019-005 DOC TYPE: PSD DOC PART: 001 REVISION: B</p> <p>MATERIAL NUMBER: SEE TABLE CUSTOMER: GENERAL MARKET SHEET NUMBER: 1 OF 1</p>			
GENERAL TOLERANCES (UNLESS SPECIFIED)							
4 PLACES ±		± 0.02					
3 PLACES ±		± 0.02					
2 PLACES ±		± 0.02		<p>EC NO: 711366 DRWN: VHANDI 2021/12/23</p> <p>CHKD: RSTONE 2022/06/21</p> <p>APPR: BWOODMAN 2022/06/24</p> <p>INITIAL REVISION: 2013/01/21</p> <p>DRWN: RSTONE 2013/03/01</p> <p>APPR: JFMURPHY</p>			
1 PLACE ±		± 0.5		<p>DRAFT WHERE APPLICABLE MUST REMAIN WITHIN DIMENSIONS</p> <p>THIRD ANGLE PROJECTION</p> <p>DRAWING: B-SIZE SERIES: 130019</p>			
0 PLACES ±		±					