



**HumPRC 900MHz Long-Range  
Handheld Transmitter  
Data Guide**

**Wireless made simple<sup>®</sup>**



**Warning:** Some customers may want Linx radio frequency (“RF”) products to control machinery or devices remotely, including machinery or devices that can cause death, bodily injuries, and/or property damage if improperly or inadvertently triggered, particularly in industrial settings or other applications implicating life-safety concerns (“Life and Property Safety Situations”).

**NO OEM LINX REMOTE CONTROL OR FUNCTION MODULE SHOULD EVER BE USED IN LIFE AND PROPERTY SAFETY SITUATIONS.**

No OEM Linx Remote Control or Function Module should be modified for Life and Property Safety Situations. Such modification cannot provide sufficient safety and will void the product’s regulatory certification and warranty.

Customers may use our (non-Function) Modules, Antenna and Connectors as part of other systems in Life Safety Situations, but only with necessary and industry appropriate redundancies and in compliance with applicable safety standards, including without limitation, ANSI and NFPA standards. It is solely the responsibility of any Linx customer who uses one or more of these products to incorporate appropriate redundancies and safety standards for the Life and Property Safety Situation application.

**Do not use this or any Linx product to trigger an action directly from the data line or RSSI lines without a protocol or encoder/decoder to validate the data.** Without validation, any signal from another unrelated transmitter in the environment received by the module could inadvertently trigger the action.

**All RF products are susceptible to RF interference that can prevent communication.** RF products without frequency agility or hopping implemented are more subject to interference. This module does not have a frequency hopping protocol built in.

**Do not use any Linx product over the limits in this data guide.** Excessive voltage or extended operation at the maximum voltage could cause product failure. Exceeding the reflow temperature profile could cause product failure which is not immediately evident.

**Do not make any physical or electrical modifications to any Linx product.** This will void the warranty and regulatory and UL certifications and may cause product failure which is not immediately evident.

# Table of Contents

- 1 Description
- 1 Features
- 1 Applications
- 2 Ordering Information
- 2 Electrical Specifications
- 3 Theory of Operation
- 4 Button Assignments
- 4 Assembly Diagram
- 5 Contention Considerations
- 5 Battery Replacement
- 6 Joining a Transmitter
- 7 Labeling / Instruction Requirements
- 8 Typical Applications
- 10 Operation with the HumPRO™ Series
- 11 Transmitter Schematic



# PRC Long-Range Handheld Transmitter

## Data Guide



### Description

The OTX-900-HH-LR8-PRC Long-Range Handheld Transmitter is ideal for general-purpose remote control and command applications that require longer transmission distances. This unit has been pre-certified for FCC Part 15 and Industry Canada compliance, reducing costs and time to market. Operating in the 900MHz band, this small remote has a transmission range of up to 0.8 mile (1,300m) depending on the receiver antenna and operating environment.

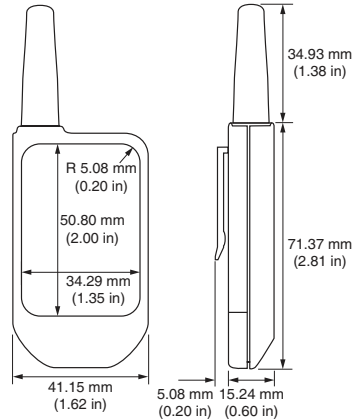

The transmitter incorporates the HumPRC™ Series transceiver module. This module uses a Frequency Hopping Spread Spectrum (FHSS) protocol to achieve longer range and higher noise immunity than narrowband radios. An automatic acknowledgement LED lets the user know that the receiver got the transmission.

Figure 1: Package Dimensions



The transmitter can be configured with 1 to 8 buttons and the keypad and labeling can be customized. It uses a single 3V CR2032 lithium button cell.

Figure 2: With a one-time NRE and minimum order, Linx can configure the keypad and label areas to meet your specific requirements.

### Features

- FCC and Canada pre-certified
- 1 to 8 buttons
- Small package
- Customizable keypad

### Applications

- Long-range remote control
- Keyless entry
- Garage / gate openers
- Lighting control
- Call systems
- Home / industrial automation

## Ordering Information

Ordering Information	
Part Number	Description
OTX-900-HH-LR8-PRC	900MHz HumPRC™ Long-Range Handheld Transmitter
HUM-900-PRC	900MHz HumPRC™ Series Remote Control Transceiver, Castellatation Interface, External Antenna Connection
HUM-900-PRC-CAS	900MHz HumPRC™ Series Remote Control Transceiver, Certified, Castellatation Interface, External Antenna Connection
HUM-900-PRC-UFL	900MHz HumPRC™ Series Remote Control Transceiver, Certified, Castellatation Interface, u.FL Connector
HUM-900-PRO	900MHz HumPRO™ Series Data Transceiver, Castellatation Interface, External Antenna Connection
HUM-900-PRO-CAS	900MHz HumPRO™ Series Data Transceiver, Certified, Castellatation Interface, External Antenna Connection
HUM-900-PRO-UFL	900MHz HumPRO™ Series Data Transceiver, Certified, Castellatation Interface, u.FL Connector
MDEV-900-PRC	900MHz HumPRC™ Series Master Development System

Figure 3: Ordering Information

## Electrical Specifications

Electrical Specifications						
Parameter	Designation	Min.	Typ.	Max.	Units	Notes
Power Supply						
Operating Voltage	$V_{CC}$	2.1	3.0	3.6	VDC	
Supply Current	$I_{CC}$		38		mA	1
Power-Down Current	$I_{PDN}$			1.0	$\mu$ A	
Transmitter Section						
Transmit Frequency Range	$F_C$	902		928		MHz
Environmental						
Operating Temperature Range		-40		+85	$^{\circ}$ C	2,3
<ol style="list-style-type: none"> <li>For a 1-second button press</li> <li>Characterized, but not tested</li> <li>The coin cell battery may limit the operating temperature range; check the manufacturer's reccomendations</li> </ol>						

Figure 4: Electrical Specifications

## Theory of Operation

The OTX-900-HH-LR8-PRC Long-Range Handheld Transmitter uses a HumPRC™ Series transceiver to form a simple, yet highly reliable RF remote control transmitter. The HumPRC™ Series transceiver is a low-cost, high performance FSK radio that utilizes a proprietary Frequency Hopping Spread Spectrum (FHSS) technique and over-the-air protocol. The FHSS offers much greater noise immunity and range than traditional narrow-band transmitters.

When a button is pressed on the transmitter, power is applied to the internal circuitry and the module is enabled. The module detects the logic states of the button data lines. These states are formatted into a packet and transmitted repeatedly until the button is released.

The receiving module checks the addressing in the received packet (and encryption, if enabled). If the packet is valid and intended for the receiver, then the module replicates the transmitter's button states on its outputs. These outputs can then be used to activate whatever external circuitry is required by the application.

The transmitter is compatible with the HumPRC™ and HumPRO™ product families. Ranges of up to 0.8 mile (1,300m) are possible with good antennas and a quiet, line-of-sight environment. Applications operating over shorter distances also benefit from the increased link reliability and superior noise immunity provided by the radio and protocol.

By building on the HumPRO™ Series data module, it is simple to create mixed-mode systems that combine data transmissions with remote control functionality. For example, a single HumPRO™ Series transceiver can accept remote control commands from the handheld transmitter as well as sensor values from other devices in system. This greatly reduces system cost and complexity and opens up many options for the creative designer.

## Button Assignments

Figure 5 illustrates the relationship between the button locations and encoder data lines.

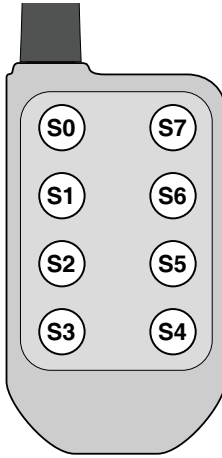

Figure 5: Button Assignments

## Assembly Diagram

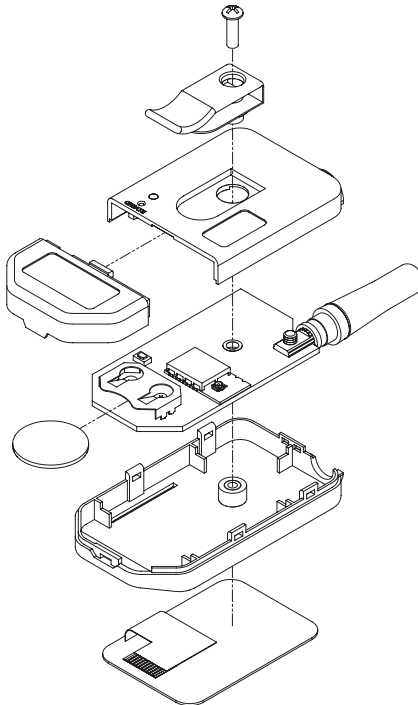

Figure 6: Assembly Diagram



## Contention Considerations

It is important to understand that even though the transmitter uses a frequency hopping protocol, it is still possible for interference to interrupt the transmissions. While the transmitted signal consists of encoded digital data, only one carrier of any particular frequency can occupy airspace without contention at any given time. If two transmitters are activated in the same area at the same time and on the same frequency, then the signals will interfere with each other and the receiver will not see a valid transmission, so it will not take any action.

## Battery Replacement

The remote unit utilizes a CR2032 lithium button cell. In normal use with five 2-second activations per day, the battery provides over two years of operation. To replace the battery, remove the access cover by pressing firmly on the label area and sliding it off. Once the unit is open, remove the battery by sliding it from beneath the holder. Replace it with the same type of battery while observing the polarity shown in Figure 7.

There may be the risk of explosion if the battery is replaced by the wrong type.

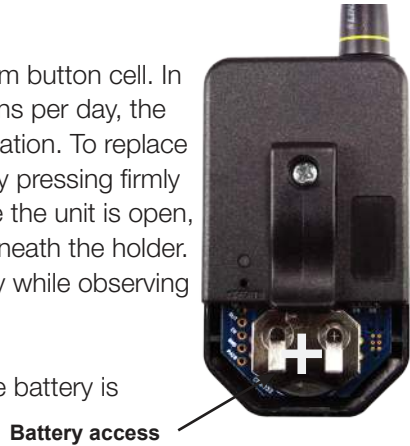

Figure 7: Battery Access

## Joining a Transmitter

The handheld transmitter is associated with a receiver using the built-in Join Process. This process configures a star network with the central unit as the system Administrator. Other units are added to the network as nodes one at a time. Typically, the handheld transmitter is added as a node to a module that has been configured as an administrator.

The schematic for a HumPRC™ Series transceiver configured as a receiver is shown in the Typical Applications section. The transceiver is set as an Administrator by pressing and holding the PAIR button for 30 seconds. While the button is held, the MODE\_IND line is on. After 30 seconds, the MODE\_IND line repeats a double blink, indicating that the operation has begun. When the button is released the key and address generation are complete and the module is an Administrator. A full explanation of this operation is in the HumPRC™ Series data guide.

The handheld transmitter is joined to an Administrator by pressing and releasing the PAIR buttons on both units. The modules automatically search for each other using a special protocol. When they find each other, the administrator sends the node the encryption key, UMASK and its network address. The UDESTID is set to the address of the administrator. The values are encrypted using a special factory-defined key. Once the JOIN process is complete, the MODE\_IND blinks on both units and they now operate together.



Figure 8: PAIR Button Access

## Labeling / Instruction Requirements

The transmitter has been pre-certified for FCC Part 15 and Industry Canada license-exempt RSS standards for an intentional radiator. It has already been labeled in accordance with FCC and Industry Canada regulations. No further labeling of the unit is needed; however, it is necessary to include the following statement in the end product's instruction manual or insert card.

### **INSTRUCTION TO THE USER**

This device complies with Part 15 of the FCC Rules and Industry Canada license-exempt RSS standard(s). Operation of this device is subject to the following two conditions:

1. This device may not cause harmful interference, and
2. This device must accept any interference received, including interference that may cause undesired operation.

This equipment has been tested and found to comply with the limits for a Class B digital device, pursuant to Part 15 of the FCC Rules. These limits are designed to provide reasonable protection against harmful interference in a residential installation. This equipment generates, uses and can radiate radio frequency energy and, if not installed and used in accordance with the instructions, may cause harmful interference to radio communications. However, there is no guarantee that interference will not occur in a particular installation. If this equipment does cause harmful interference to radio or television reception, which can be determined by turning the equipment off and on, the user is encouraged to try to correct the interference by one or more of the following measures:

- Reorient or relocate the receiving antenna.
- Increase the separation between the equipment and receiver.
- Connect the equipment into an outlet on a circuit different from that to which the receiver is connected.
- Consult the dealer or an experienced radio / TV technician for help.

The user is cautioned that changes and modifications made to the equipment without the approval of manufacturer could void the user's authority to operate this equipment.

Le présent appareil est conforme aux CNR d'Industrie Canada applicables aux appareils radioexempts de licence. L'exploitation est autorisée aux deux conditions suivantes : (1) l'appareil ne doit pas produire de brouillage, et (2) l'utilisateur de l'appareil doit accepter tout brouillage radioélectrique subi, même si le brouillage est susceptible d'en compromettre le fonctionnement.

## Typical Applications

The signal sent by the PRC Long-Range Handheld Transmitter can be received by a HumPRC™ Series transceiver. When a button is pressed on the transmitter, a corresponding line on the transceiver goes high. This is then connected to external circuitry to perform whatever function is required by the application.



Figure 9: Standard (top) and Pre-certified (bottom) HumPRC™ Modules

The transmitter and transceiver must first learn each other's addresses. This is done by taking the PAIR line high on the transceiver, typically with a pushbutton switch. At the same time, the PAIR button is pressed on the back of the transmitter, typically with a paper clip or similar probe. The MODE\_IND line on the transceiver and the LED on the back of the transmitter begin flashing, indicating that the Pair Process has been started. The devices automatically find each other and swap addresses. The MODE\_IND line and LED flash to indicate that the process was successful and the devices are ready to use.

Figure 10 shows a typical schematic for the HumPRC™ Series transceiver being used as a receiver only. The C0 and C1 lines are pulled to ground, setting all of the status lines as outputs.

The MODE\_IND line is connected to an LED to provide visual feedback to the user that an action is taking place.

The PAIR line is connected to a pushbutton switch for activating the Join Process.

The ACK\_EN line is pulled to supply so that the module will send an acknowledgement as soon as it receives a signal. Alternatively, this line can be connected to external circuitry to take the line high when an action has taken place. For example, a circuit can take the line high when a motor has actually stopped or a door has actually locked. This way the LED on the handheld lights up only when the desired action has occurred.

Additional features can be enabled through the module's Command Data Interface. The data guide and additional documentation for the HumPRC™ Series transceiver can be found on the Linx Technologies website at [www.linxtechnologies.com](http://www.linxtechnologies.com).

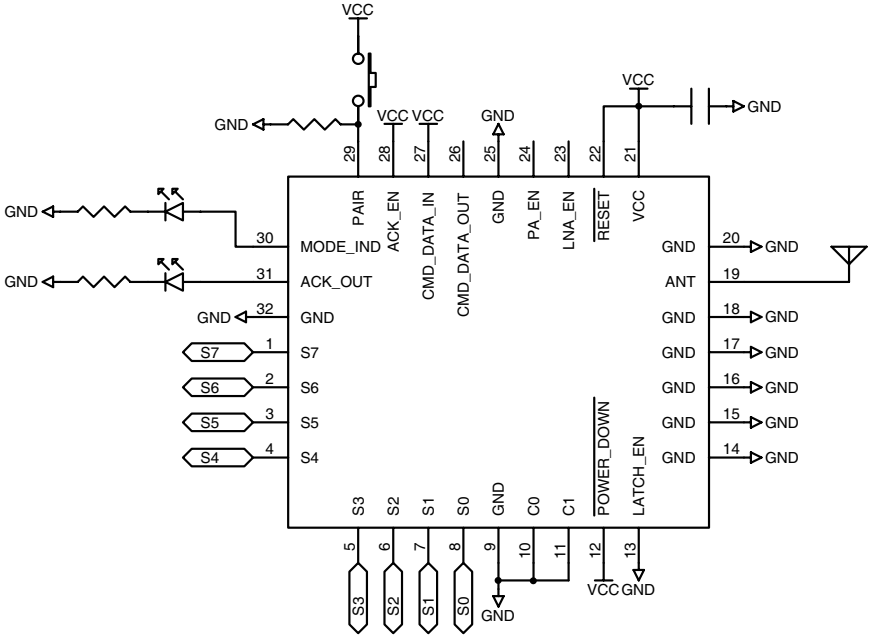

Figure 10: HumPRC™ Series as a Receiver Schematic

## Operation with the HumPRO™ Series

The commands from the handheld transmitter can be received by a HumPRO™ Series transceiver. The transmitter should be joined to the HumPRO™ Series module in the same manner as it would be joined to a HumPRC™ Series module. The transmitter sends a Remote Activation command and accepts a Remote Confirm command.

### Remote Activation

The transmission output consists of six bytes:

0x03 0x00 0x00 0x00 0x10 <STATUS>

The first byte is 0x03 with the next three bytes 0x00. Byte five is 0x10 which indicates a Remote Activation. Byte six is the STATUS byte, which is a bit map of the button states. Bit 0 corresponds to button S0 and so forth. Each bit is 1 if the corresponding line is high. The external microcontroller connected to the HumPRO™ module can read out the header from the transmission and know which transmitter sent the command. It can then take whatever action is required by the STATUS bits. Additional information about reading out the header is available in the HumPRO™ Series Transceiver data guide.

### Remote Confirm

The handheld transmitter accepts a Remote Confirm command over the air to control the LED in the membrane switch. This command has the following format:

0x00 0x11 <DURATION> <ALIVE>

The first two bytes are 0x00 0x11 and indicate that the packet is a remote confirm packet.

The DURATION byte indicates the amount of time that the LED should be held high. This value is multiplied by 10ms. If the value is 0, the LED output is immediately taken low.

The ALIVE byte indicates how long after the transmission the module should stay awake in receive mode. This value is multiplied by 0.1s. Once this duration expires, the module returns to sleep mode.

This message is transmitted to the handheld transmitter's address. It must be received by the handheld transmitter within one second of initial

transmission or within the ALIVE interval of the previous Remote Confirm message.

## Transmitter Schematic

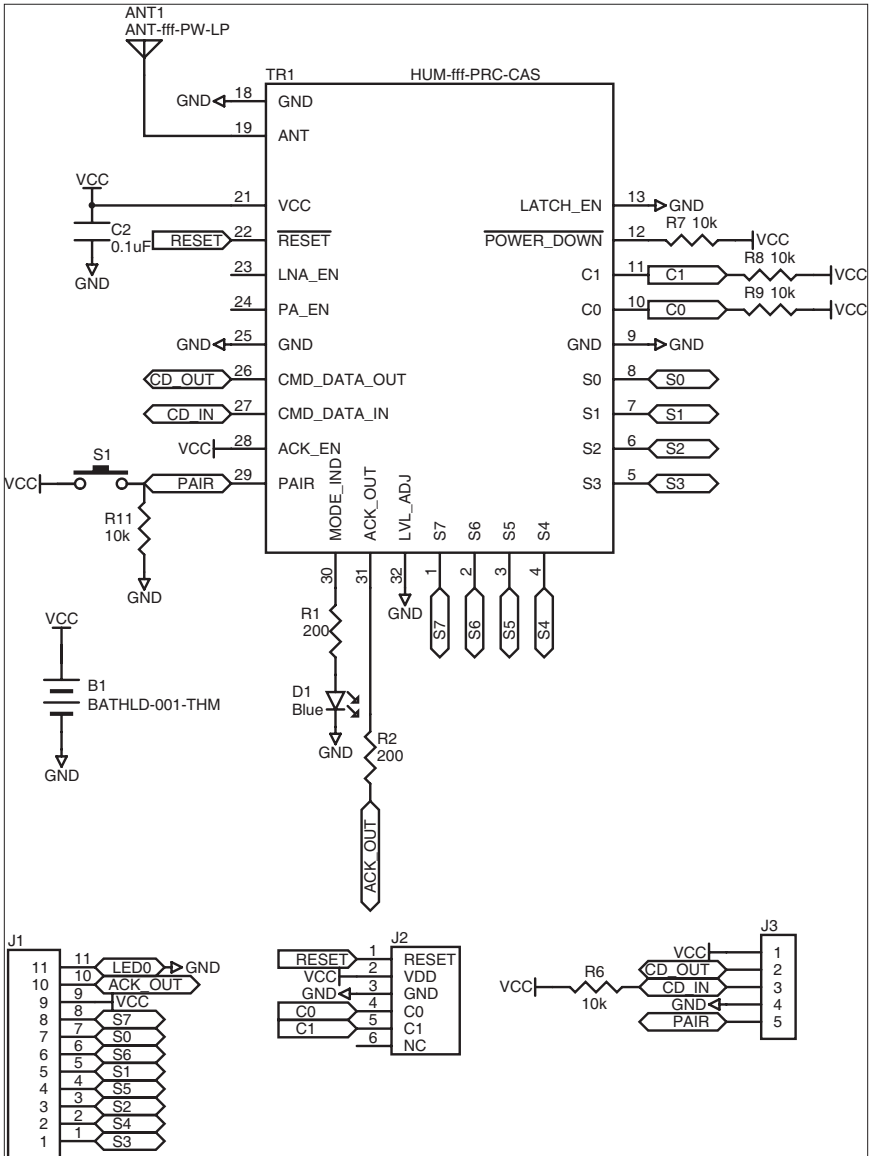

Figure 11: OTX-900-HH-LR8-PRC Schematic Diagram



Linx Technologies  
159 Ort Lane  
Merlin, OR, US 97532

Phone: +1 541 471 6256  
Fax: +1 541 471 6251

[www.linxtechnologies.com](http://www.linxtechnologies.com)

---

#### Disclaimer

Linx Technologies is continually striving to improve the quality and function of its products. For this reason, we reserve the right to make changes to our products without notice. The information contained in this Data Guide is believed to be accurate as of the time of publication. Specifications are based on representative lot samples. Values may vary from lot-to-lot and are not guaranteed. "Typical" parameters can and do vary over lots and application. Linx Technologies makes no guarantee, warranty, or representation regarding the suitability of any product for use in any specific application. It is the customer's responsibility to verify the suitability of the part for the intended application. **NO LINX PRODUCT IS INTENDED FOR USE IN ANY APPLICATION WHERE THE SAFETY OF LIFE OR PROPERTY IS AT RISK.**

Linx Technologies **DISCLAIMS ALL WARRANTIES OF MERCHANTABILITY AND FITNESS FOR A PARTICULAR PURPOSE. IN NO EVENT SHALL LINX TECHNOLOGIES BE LIABLE FOR ANY OF CUSTOMER'S INCIDENTAL OR CONSEQUENTIAL DAMAGES ARISING IN ANY WAY FROM ANY DEFECTIVE OR NON-CONFORMING PRODUCTS OR FOR ANY OTHER BREACH OF CONTRACT BY LINX TECHNOLOGIES.** The limitations on Linx Technologies' liability are applicable to any and all claims or theories of recovery asserted by Customer, including, without limitation, breach of contract, breach of warranty, strict liability, or negligence. Customer assumes all liability (including, without limitation, liability for injury to person or property, economic loss, or business interruption) for all claims, including claims from third parties, arising from the use of the Products. The Customer will indemnify, defend, protect, and hold harmless Linx Technologies and its officers, employees, subsidiaries, affiliates, distributors, and representatives from and against all claims, damages, actions, suits, proceedings, demands, assessments, adjustments, costs, and expenses incurred by Linx Technologies as a result of or arising from any Products sold by Linx Technologies to Customer. Under no conditions will Linx Technologies be responsible for losses arising from the use or failure of the device in any application, other than the repair, replacement, or refund limited to the original product purchase price. Devices described in this publication may contain proprietary, patented, or copyrighted techniques, components, or materials. Under no circumstances shall any user be conveyed any license or right to the use or ownership of such items.

---

©2018 Linx Technologies. All rights reserved.

The stylized Linx logo, Wireless Made Simple, WISE, CipherLinx and the stylized CL logo are trademarks of Linx Technologies.