

TOP VIEW

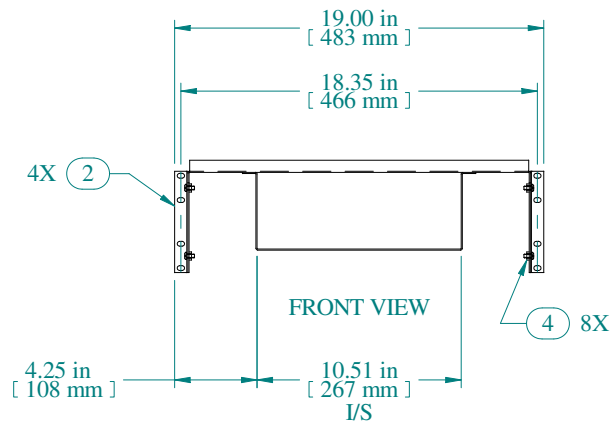

FRONT VIEW

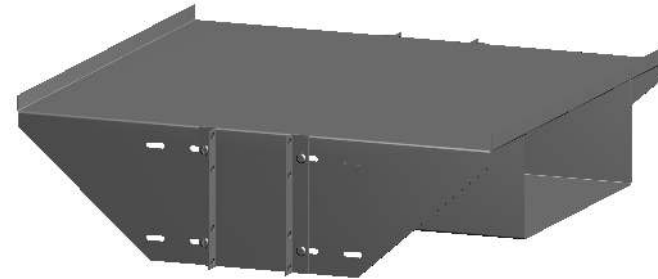
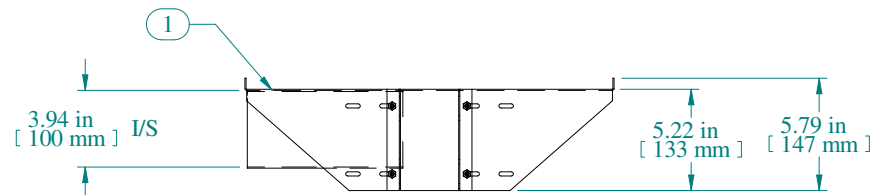

SIDE VIEW

Item Number	Title	Quantity
1	DNRM - SHELF WITH ACCESSORY COMPARTMENT	1
2	DNRM - MTG BRACKET	4
3	SCREW 10-32 X 3/8	8
4	10-32 KEP NUT	8

Data subject to change without notice. Isometric drawing not to scale.

PART NUMBERS	
DNRMM19BK1	PAINTED BLACK TEXTURED

NOTES
Maximum Weight 300 lb Mounting Hardware Included for 10-32 & 12-24 Tapped Rails Some Assembly Required

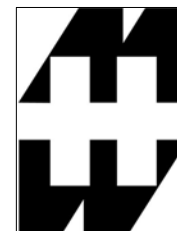

**HAMMOND  
MANUFACTURING™**

www.hammondmfg.com

PART NO. DNRMM19