

PLC-APT-PT100-IN - Analog module



2906919

<https://www.phoenixcontact.com/us/products/2906919>

Please be informed that the data shown in this PDF document is generated from our online catalog. Please find the complete data in the user documentation. Our general terms of use for downloads are valid.



Pt 100/Pt 1000 temperature transducer for PLC logic logic modules (Generation 2 only), single-channel, signal type (Pt 100, Pt 1000) can be configured via DIP switch, Push-in connection

Commercial data

Item number	2906919
Packing unit	1 pc
Minimum order quantity	1 pc
Sales key	C424
Product key	CK2622
Catalog page	Page 433 (C-5-2019)
GTIN	4055626155500
Weight per piece (including packing)	73 g
Weight per piece (excluding packing)	50.3 g
Customs tariff number	85389099
Country of origin	DE

Technical data

Notes

General	For proper use, the specifications of the installation directive (see Downloads) must be observed.
---------	--

Product properties

Product type	Extension module
Product family	PLC logic
Operating mode	100% operating factor

Insulation characteristics

Insulation	Basic insulation
------------	------------------

Insulation characteristics: Air clearances and creepage distances

Insulation	Basic insulation
Overvoltage category	III
Pollution degree	2

Electrical properties

Air clearances and creepage distances

Rated insulation voltage	50 V
Rated surge voltage	0.5 kV

Supply

Rated control circuit supply voltage U_S	24 V DC
Rated control supply voltage range with reference to U_S	0.8 ... 1.1
Rated control supply current I_S	14 mA
Protective circuit	Reverse polarity protection
	Surge protection

Input data

Analog input resistance

Sensor types (RTD) that can be used	Pt 100 (IEC 60751, $\alpha = 0,00385$)
Number of inputs	1
Connection technology	2-conductor
Sensor input current	900 μ A
Temperature measuring range	-50 °C ... 200 °C
Maximum temperature coefficient	0.01 %/K
Maximum transmission error	1 %
Surge voltage protection	> 33 V
Resolution	10 bit (scaled to 0 to 1000)

Analog input resistance

Sensor types (RTD) that can be used	Pt 1000 (IEC 60751, $\alpha = 0.00385$)
-------------------------------------	--

PLC-APT-PT100-IN - Analog module



2906919

<https://www.phoenixcontact.com/us/products/2906919>

Number of inputs	1
Connection technology	2-conductor
Sensor input current	900 μ A
Temperature measuring range	-50 °C ... 200 °C
Maximum temperature coefficient	0.01 %/K
Maximum transmission error	1 %
Surge voltage protection	> 33 V
Resolution	10 bit (scaled to 0 to 1000)

Output data

Digital

Output name	Digital output
Switching voltage range	5 V DC ... 30 V DC
Switching current	\leq 3 mA

Connection data

Connection method	Push-in connection
Stripping length	10 mm
Number of connections	4
Conductor cross section rigid	0.14 mm ² ... 2.5 mm ²
Conductor cross section flexible	0.14 mm ² ... 2.5 mm ²
Conductor cross section AWG	26 ... 14

Signaling

Operating voltage display	Green LED
Error indication	Red LED

Dimensions

Width	6.2 mm
Height	80 mm
Depth	86 mm

Environmental and real-life conditions

Ambient conditions

Degree of protection	IP20
Ambient temperature (operation)	-20 °C ... 50 °C
Ambient temperature (storage/transport)	-20 °C ... 70 °C

Approvals

CE

Certificate	CE-compliant
-------------	--------------

UL, USA/Canada

Identification	UL 508 Listed
----------------	---------------

PLC-APT-PT100-IN - Analog module



2906919

<https://www.phoenixcontact.com/us/products/2906919>

Standards and regulations

Air clearances and creepage distances

Standards/regulations	DIN EN 50178
-----------------------	--------------

Mounting

Mounting type	DIN rail mounting
Assembly instructions	in rows with zero spacing
Mounting position	any

PLC-APT-PT100-IN - Analog module

2906919

<https://www.phoenixcontact.com/us/products/2906919>

Drawings

Block diagram

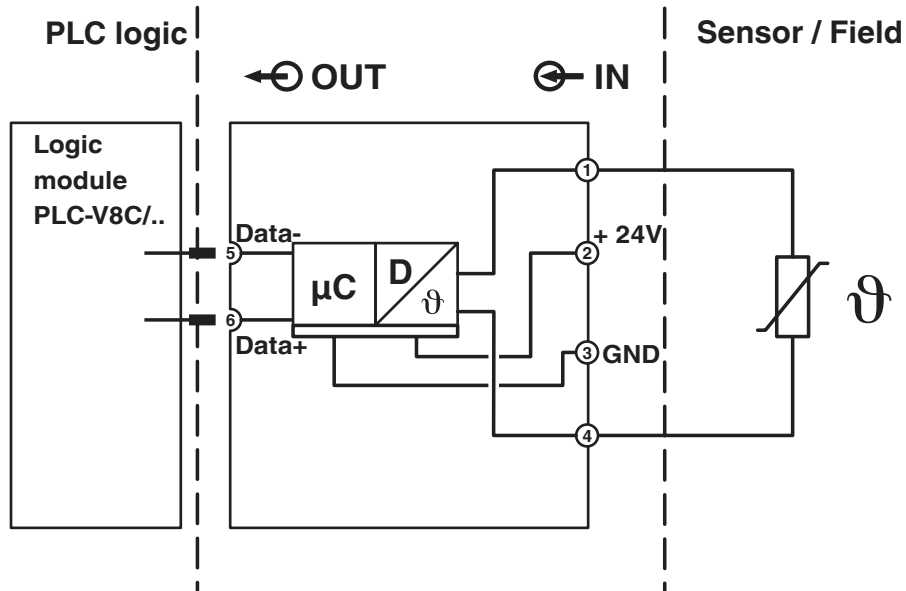

PLC-APT-PT100-IN - Analog module



2906919

<https://www.phoenixcontact.com/us/products/2906919>

Approvals

To download certificates, visit the product detail page: <https://www.phoenixcontact.com/us/products/2906919>



EAC

Approval ID: RU*DE.*08.B.01517/19



UL Listed

Approval ID: FILE E 238705



cUL Listed

Approval ID: FILE E 238705

cULus Listed

PLC-APT-PT100-IN - Analog module



2906919

<https://www.phoenixcontact.com/us/products/2906919>

Classifications

ECLASS

ECLASS-11.0	27242201
ECLASS-13.0	27242201
ECLASS-12.0	27242201

ETIM

ETIM 8.0	EC001420
----------	----------

UNSPSC

UNSPSC 21.0	32151600
-------------	----------

PLC-APT-PT100-IN - Analog module



2906919

<https://www.phoenixcontact.com/us/products/2906919>

Environmental product compliance

REACH SVHC	Lead 7439-92-1
China RoHS	Environmentally Friendly Use Period = 50 years
	For information on hazardous substances, refer to the manufacturer's declaration available under "Downloads"

Phoenix Contact 2023 © - all rights reserved

<https://www.phoenixcontact.com>

Phoenix Contact USA
586 Fulling Mill Road
Middletown, PA 17057, United States
(+717) 944-1300
info@phoenixcon.com