

CHEMINAX

70 OHM, AWG 24, 19 STRANDS OF AWG 36,
RADIO FREQUENCY, MULTIPLEX DATA BUS

Date: 04-09-04
Revision: H

THIS SPECIFICATION SHEET FORMS A PART OF THE LATEST ISSUE OF RAYCHEM SPECIFICATION 1200.

Page 1 of 2
Page 2 is for Internal use only.

CONSTRUCTION DETAILS

ELECTRICAL CHARACTERISTICS

DIMENSIONS ARE NOMINAL VALUES IN INCHES UNLESS OTHERWISE DESIGNATED.

| | |
|--------------------------|--|
| CHARACTERISTIC IMPEDANCE | 70 ± 5 ohms, Method C at 1 MHz |
| CAPACITANCE - MUTUAL | 30 pF/ft. (maximum) |
| ATTENUATION | 1.0 dB/100 ft. (nominal) at 1 MHz 1.4 dB/100 ft. (maximum) at 1 MHz |

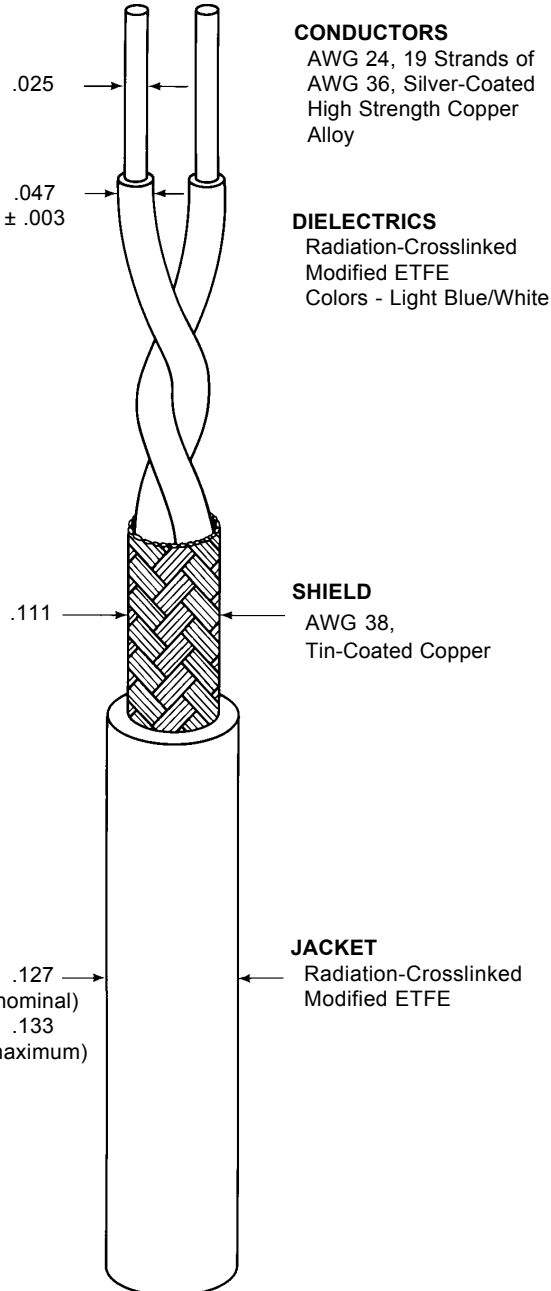

CONDUCTORS
AWG 24, 19 Strands of
AWG 36, Silver-Coated
High Strength Copper
Alloy

DIELECTRICS
Radiation-Crosslinked
Modified ETFE
Colors - Light Blue/White

SHIELD
AWG 38,
Tin-Coated Copper

JACKET
Radiation-Crosslinked
Modified ETFE

ADDITIONAL REQUIREMENTS

COMPONENT WIRE PRIOR TO CABLING (Test procedures per MIL-W-22759)

| | |
|--|--|
| CROSSLINKPROOF | 300 ± 3°C for 1 hour, .625 inch mandrel, .375 lb., 2.5 kV dielectric test |
| LOW TEMPERATURE - COLDBEND | -65 ± 2°C for 4 hours, .500 inch mandrel, 1.00 lb., 2.5 kV dielectric test |
| SHRINKAGE | 200 ± 3°C for 1 hour, .125 inch (maximum) in 12 inches |
| INSULATION RESISTANCE | 5000 megohms for 1000 ft. (minimum) |
| INSULATION (DIELECTRIC) TENSILE STRENGTH | 5000 lbf/in ² (minimum) |
| ELONGATION | 50% (minimum) |
| INSULATION FLAWS SPARK TEST | 3000 volts (rms) |
| IMPULSE TEST | 8.0 kV (peak) |

FINISHED CABLE (Test procedures per NEMA WC27500)

| | |
|--------------------------------|--|
| BLOCKING | 200°C for 6 hours |
| LOW TEMPERATURE - COLDBEND | -55 ± 5°C for 4 hours, 6.00 inch mandrel |
| CROSSLINKED VERIFICATION | 300 ± 5°C for 6 hours, 6.00 inch mandrel |
| FLAMMABILITY | 3 seconds (maximum); 3.0 inches (maximum), no flaming of facial tissue |
| JACKET FLAWS SPARK TEST | 1000 volts (rms) |
| IMPULSE TEST | 6.0 kV (peak) |
| JACKET TENSILE STRENGTH | 5000 lbf/in ² (minimum) |
| ELONGATION | 50% (minimum) |
| SHIELD COVERAGE | 90% (minimum) |
| JACKET THICKNESS | .008 inch (nominal) |
| VOLTAGE WITHSTAND (DIELECTRIC) | 1500 volts (rms) |

Outer jacket color will be white (designated by a "-9" appended to the part number, e.g. 10595-9) unless otherwise specified.

Designate outer jacket color with a dash number in accordance with MIL-STD-681. Other codes and suffixes may be added to the part number, as necessary, to capture any additional requirements imposed by the purchase order.

Replaces EPD5618 and 5671

The length of lay shall be .75 inch (minimum) to 1.25 inches (maximum)

WEIGHT 13.4 lbs/1000 ft. (maximum)

Users should evaluate the suitability of this product for their application. Specifications are subject to change without notice. Tyco Electronics also reserves the right to make changes in materials or processing, which do not affect compliance with any specification, without notification to Buyer.