

CRIMPING DIES USED IN . . .					
CRIMPING HEAD 69082, 1752786-1			CRIMPING HEAD 69099, 1752868-1		
68034	68035	68036	68043	68044	68045
68037	68037-1	68050	68046	68047	
			68048	68049	

Figure 1

1. INTRODUCTION

This instruction sheet covers the use of Crimping Die Assemblies listed in Figure 1, which are used to crimp COPALUM Terminals and Splices and HF-30 Pin and Socket Contacts. The die assemblies are used in Crimping Heads 69082, 69099, 1752786-1, and 1752868-1. Refer to instruction sheet packaged with the crimping head for information concerning die installation and general performance of the head. Read these instructions thoroughly before using the die assemblies.

See Section 7, REVISION SUMMARY, for revision information.

NOTE All dimensions on this document are in metric units [with U.S. customary units in brackets]. Figures and illustrations are for reference only and are not drawn to scale.

2. DESCRIPTION

The die assemblies consist of stationary dies (nest) and moving dies (indenter). Refer to Figure 2A (COPALUM contacts) or Figure 2B (HF-30 Contacts) to ensure the compatibility of die assemblies, crimping heads, and terminals and splices. These dies are used to crimp COPALUM Terminals and Splices on No. 8 through 500 MCM stranded or solid,

†Butt Splices Only. Refer to Paragraph 3.3

aluminum or copper† wire and HF-30 Pin and Socket Contacts for stranded aluminum and copper wire sizes specified in Figure 2B.

Dies are coated with preservative to prevent rust and corrosion. Wipe this preservative away from dies, particularly from crimping areas.

For further instructions on the hydraulic power unit and hydraulic crimping heads, refer to the instructions packaged with these tools.

2.1. Die Installation



AVOID PERSONAL INJURY. Exercise extreme caution when using power unit. Avoid depressing foot switch or trigger control when installing or removing die assemblies. **DO NOT MIX DIE COMPONENTS FROM DIFFERENT DIE SETS.**

The radii of both dies must match the radii of the tool. See Figure 1.

Crimping head No. 69099 is illustrated throughout this publication; however, die insertion, die removal and crimping instructions are the same for 69099, 69082, 1752786-1, and 1752868-1 crimping heads.

Proceed as follows:

1. Loosen retaining screw in top section of crimping head. See Figure 1.

2. Insert shank of stationary die into top section of crimping head and tighten retaining screw.

See Figure 2A for COPALUM Terminal and Splices or Figure 2B for HF-30 Pin and Socket Contacts.

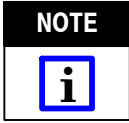

NOTE Ensure that the dies are inserted fully and that the “flats” on shanks are facing the operator.

3. Activate power unit to advance ram until setscrew is visible.



DANGER AVOID PERSONAL INJURY. Exercise extreme caution when using power unit. Avoid depressing foot switch or trigger control when installing or removing die assemblies.

4. Loosen setscrew and insert shank of moving die into ram well. Tighten setscrew.

5. Activate power unit to complete cycle and allow ram to return to down position.



CAUTION Do NOT nick or cut conductor strands. When stripping wires for HF-30 Pin and Socket Contacts, be sure to remove clear plastic insulation material from conductors prior to crimping.

2.2. Die Removal

1. Loosen retaining screw in top section of crimping head and remove die.

2. Raise ram to full up position. Loosen setscrew in ram and remove die.

3.2. Crimping COPALUM Terminals



DANGER AVOID PERSONAL INJURY; when operating power unit, exercise caution while holding terminals or wire near crimping area. Never place anything within the crimping dies except COPALUM terminals and splices and HF-30 pin and socket contacts.



DANGER AVOID PERSONAL INJURY. Exercise extreme caution when using power unit. Avoid depressing foot switch or trigger control when installing or removing die assemblies.

1. Ensure that the wire size stamped on the terminal corresponds with the size marked on the dies.

2. Center terminal wire barrel in stationary die. Terminals may be crimped with tongue facing either die. (Tyco Electronics recommends the terminal positioning shown in Figure 3:) (tongue toward moving die.)

3. WIRE STRIPPING AND CRIMPING PROCEDURE

3.1. Wire Stripping Procedure

1. Select the proper size terminal, splice, or HF-30 pin and socket contact for the wire size being used.

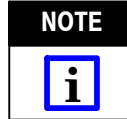

NOTE Depending on conductor hardness, and if near maximum conductor CMA limit is reached, some cracking may occur in crimp area when terminal is crimped with tongue toward stationary die.

WIRE SIZE	mm ²	CMA● RANGE	WIRE STRIP LENGTH		CRIMPING DIE ASSY	CRIMPING HEAD	
			MIN	MAX			
8	6.638 - 10.540	13,100 - 20,800	10.32 [.4062]	11.90 [.4687]	68043	69099 1752868-1	
6	10.540 - 16.772	20,800 - 33,100			68044		
4	16.772 - 26.652	33,100 - 52,600	14.29 [.5625]	15.88 [.6250]	68045		
2	26.652 - 42.412	52,600 - 83,700	18.25 [.7187]	19.84 [.7812]	68046		
1/0	42.412 - 60.55	83,700 - 119,500			68047		
2/0	60.55 - 76.26	119,500 - 150,500			68048		
3/0	76.26 - 96.27	150,500 - 190,000			68049		
4/0	96.27 - 117.049	190,000 - 231,000	19.10 [.75]	20.64 [.8125]	68050		69082 1752786-1
250 MCM	117.049 - 152.01	231,000 - 300,000	28.58 [1.125]	31.75 [1.250]	68034		
300 MCM	152.01 - 192.55	300,000 - 380,000	31.75 [1.250]	34.93 [1.375]	68035		
400 MCM	192.55 - 242.20	380,000 - 478,000	34.93 [1.375]	38.1 [1.50]	68036		
500 MCM	242.20 - 304.02	478,000 - 600,000	38.1 [1.50]	41.28 [1.625]	68037		

●Circular Mil Area Figure 2A
(For Crimping COPALUM Terminals and Splices - See Paragraphs 3.2, 3.3, and 3.4)

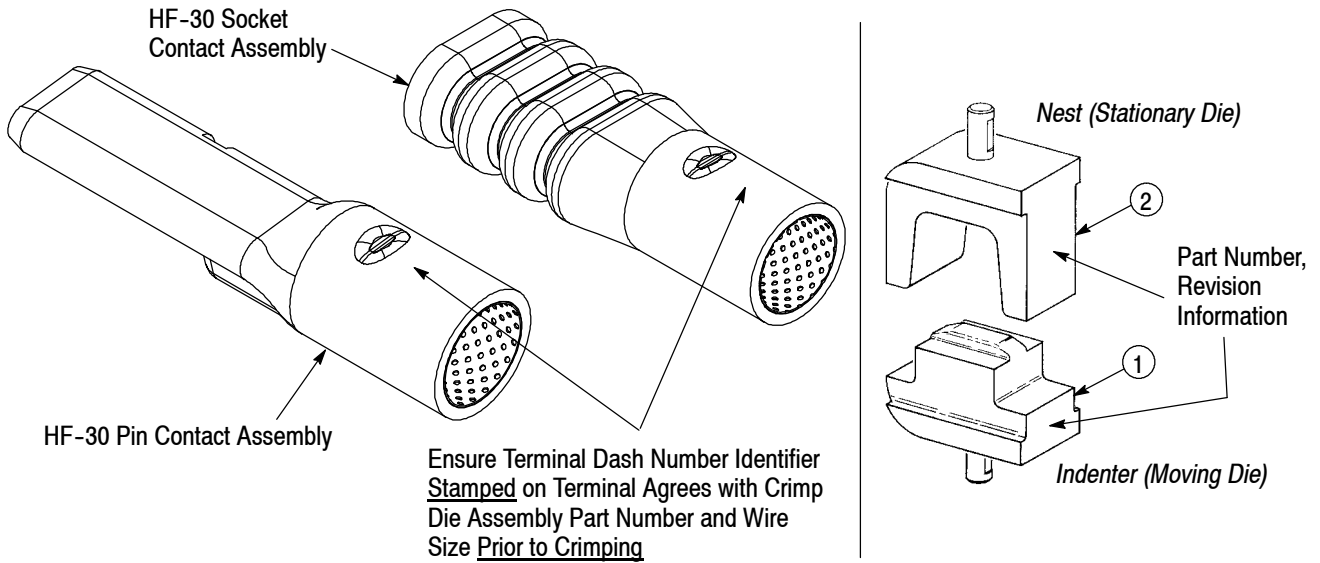

•WIRE SIZE (mm ²)	WIRE TYPE-	STAMPED WIRE AREA (mm ²)	NOMINAL WIRE CMA	WIRE STRIP LENGTH (mm)		•CRIMPING DIE ASSY.	•TERMINAL DASH NO. IDENTIFIER	•CRIMPING DIE EMBOSMENT IDENTIFIER	CRIMPING HEAD
				MIN	MAX				
185	Alum	185	365,102	23.4	26.6	---◆	-1	300	69082 1752786-1
150	Copper	150	296,029	23.4	26.6	---◆	-1	300	
240	Alum	240	473,646	25.9	29.1	---◆	-2	400	
185	Copper	185	365,102	25.9	29.1	---◆	-2	400	
300	Alum	300	592,058	29.7	32.9	68037-1◆◆	-3	600	
240	Copper	240	473,646	29.7	32.9	68037-1◆◆	-3	600	
400	Alum	400	789,410	29.7	32.9	68037◆◆	-4	500	
300	Copper	300	592,058	29.7	32.9	68037◆◆	-4	500	

•Ensure terminal dash number, crimp die assembly part number including its associated embossment identifier, and wire size stamped on wire, all agree prior to crimping. ◆ Contact Tyco Electronics Engineering for preliminary part number information. ◆◆ Pending product qualification approval.

Figure 2B

(For Crimping HF-30 Pin and Socket Contacts - See Paragraph 3.5)

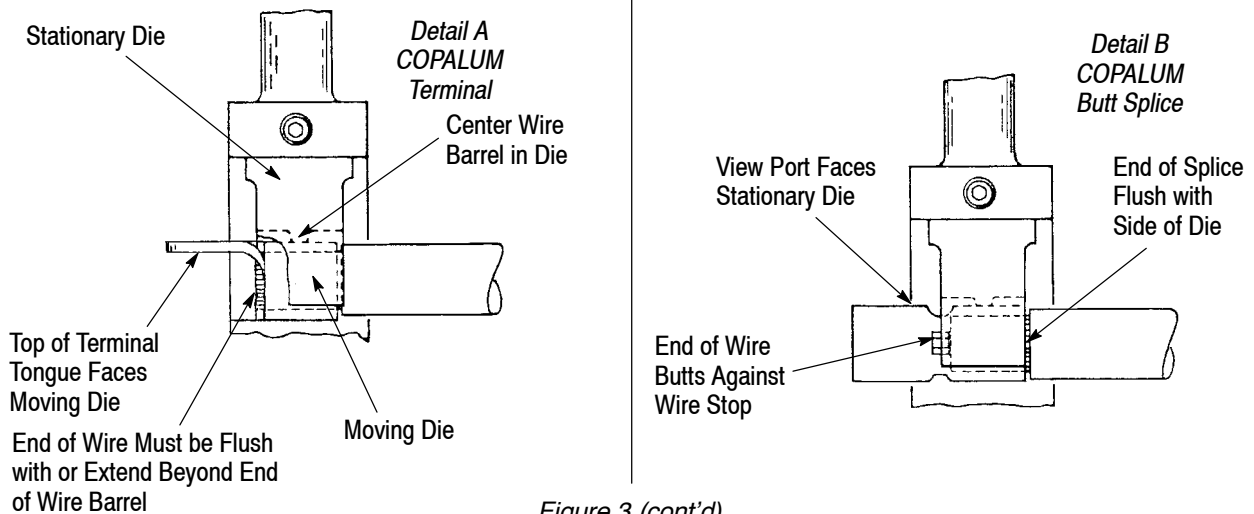
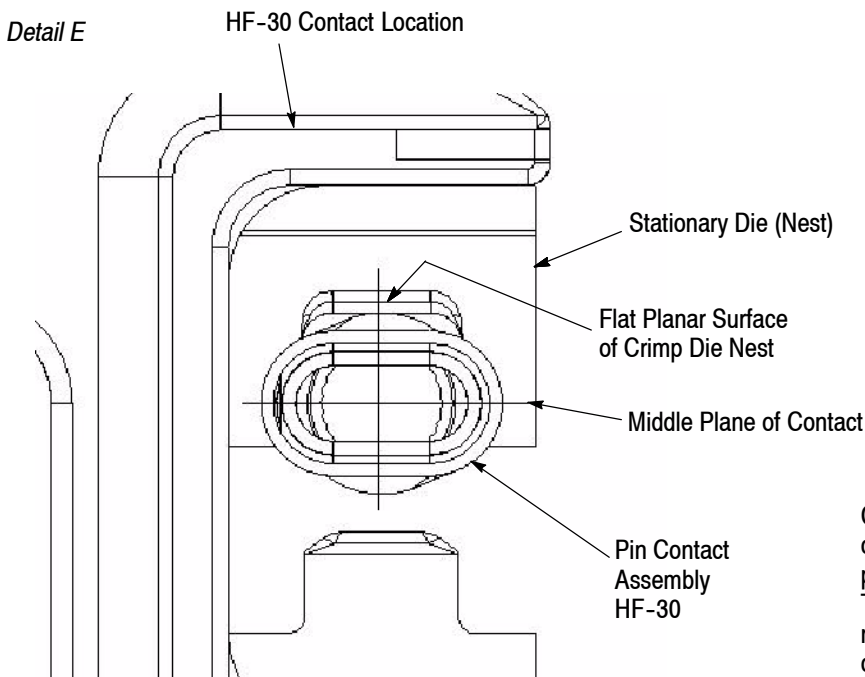
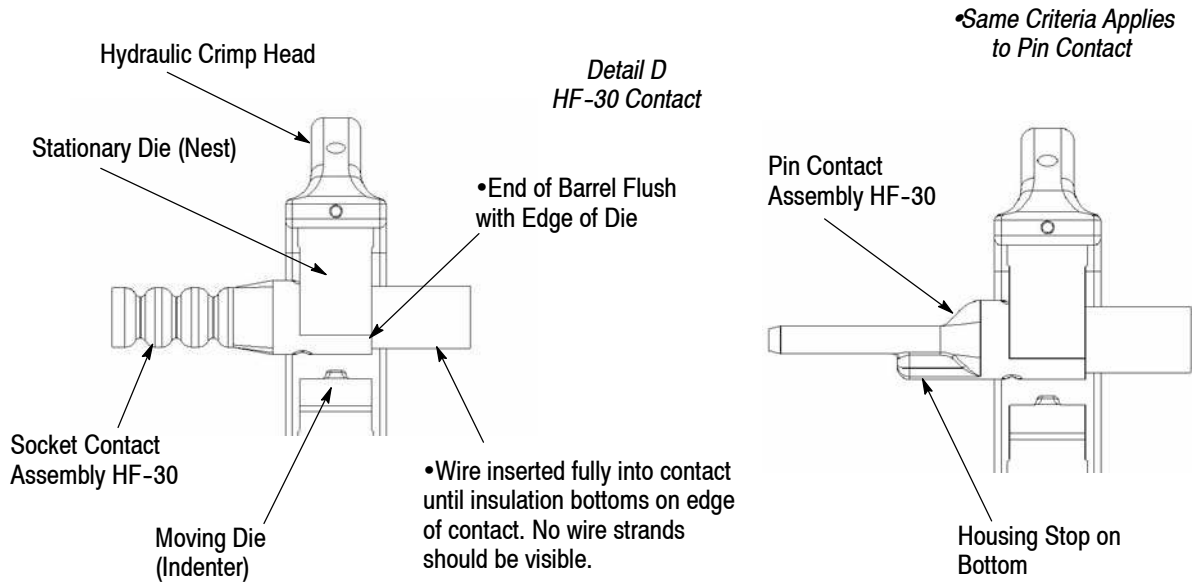
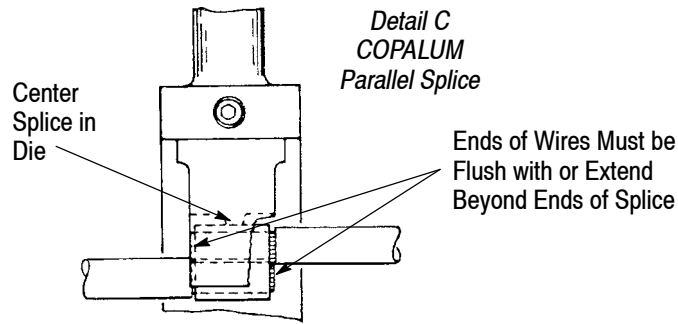

Figure 3 (cont'd)



Contact Location: The middle plane of contact should be parallel to the planar surface of the crimp die nest. This will prevent twist in the crimp relative to the planar mating surface of the contact. This applies to both pin and socket contacts.

Figure 3 (end)

3. Activate power unit so that moving die advances and holds terminal in place. Do NOT deform terminal wire barrel.

4. Insert stripped wire all the way into terminal wire barrel. End of wire must be flush with or extend beyond end of wire barrel as shown in Figure 3, Detail A. See Figure 3, (Detail D and E), for HF-30 Contacts.

5. Activate power unit to complete crimp.

6. Refer to Figure 5A and Section 4, CRIMP INSPECTION.

3.3. Crimping Procedure (COPALUM Butt Splice)

1. Position butt splice in stationary die so that end of splice is flush with sides of dies and view port in splice is facing stationary die. See Figure 3, Detail B.

2. Activate power unit so that moving die advances and holds splice in place. Do NOT deform splice wire barrel.

3. Insert stripped wire into splice wire barrel until end of wire butts against wire stop as shown in Figure 3, Detail B.

NOTE



For aluminum-to-aluminum applications, butt splices will accept the same wire size at either end. For aluminum-to-copper applications, however, the size of the copper wire must be “stepped down” to the next smaller wire size to compensate for differences in the physical properties of copper and aluminum. Determine correct splice wire loading by referring to CMA range listed in Figure 2. If “stepping down” to a smaller wire size is not desirable, i.e., if aluminum-to-copper applications are to be made using the same size wire at each end of the butt splice, Tyco Electronics recommends that the perforated sleeve be removed from inside that particular end of splice that is to be crimped on copper wire. When two or more wires are used in either end of butt splice, combined cross-sectional area must be within the CMA range listed for the splice in Figure 2.

4. Activate power unit to complete crimp.

5. To crimp other half of butt splice, remove and rotate splice 180° end-over-end. If splice cannot be rotated, rotate crimping head. Reposition uncrimped half in stationary die as described in Step 1. Insert wire and then crimp the splice.

6. Refer to Figure 5A and Section 4, CRIMP INSPECTION.

3.4. Crimping Procedure (COPALUM Parallel Splices)

1. Center parallel splice in stationary die as shown in Figure 3, Detail C.

2. Activate power unit so that moving die advances and holds splice in place. Do NOT deform the splice.

3. Insert stripped wires all the way into splice. Ends of wires must be flush with or extend beyond ends of splice.

4. Activate power unit to complete the crimp.

NOTE



If terminal or splice sticks in die after crimping, apply rocking action to remove from die.

5. Refer to Figure 5A and Section 4, CRIMP INSPECTION.

3.5. Crimping Procedure (HF-30 Pin and Socket Contacts)

1. Ensure the terminal dash number, crimp die assembly, and wire size agree with table in Figure 2B prior to crimping.

2. Visually inspect contacts for presence of insert. See Figure 4.

DANGER



Verify perforated insert is present prior to crimping contact assembly. Crimp will not function properly without insert.

3. Center pin or socket contact wire barrel in stationary die as shown in Figure 3, Detail D & E.

4. Activate power unit so that moving die advances and holds contact in place. Do NOT deform the contact wire barrel.

5. Insert properly stripped wires all the way into contact. Insulation should butt up against contact wire barrel, see criteria identified in Figure 3, Detail D.

6. Activate power unit to complete the crimp.

NOTE



If contact sticks in die after crimping, apply rocking action to remove from die. Use Tyco Electronics Lubricant (pat number 168433-1) to prevent sticking of HF-30 contacts in crimping dies. Apply a thin coat to die surfaces periodically. Do NOT lubricate excessively. Remove excess lubricant from surface as required. Lubricant transferred from the crimp area onto certain terminations may affect the electrical characteristics of an application.

7. Refer to Figure 5B and Section 4, CRIMP INSPECTION.

Crimping Die Assemblies for COPALUM* Terminals and Splices and HF-30 Pin and Socket Contacts

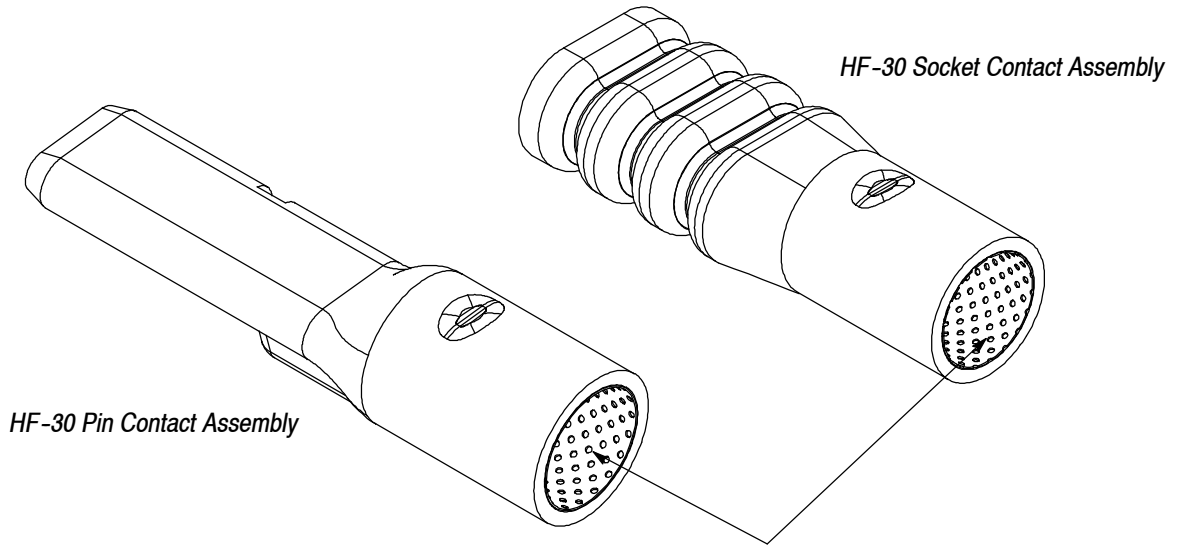

Verify perforated insert is present prior to crimping contact assembly. Crimp will not function properly without insert.

Figure 4 (See Paragraph 3.5.2)

4. CRIMP INSPECTION for COPALUM Terminals and Splices (Figure 5A) and HF-30 Pin and Socket Contacts (Figure 5B)

Inspect crimped contacts by checking the features described in Figure 5A or 5B as applicable. Use only the terminals, splices, and contacts that meet the

conditions shown in the "ACCEPT" column. "REJECT" terminals, splices, and contacts can be avoided through careful use of the tabular information in Figure 2A or 2B and the instructions Section 3, and by performing regular die maintenance as instructed in Section 5.

COPALUM Terminals and Splices

ACCEPT

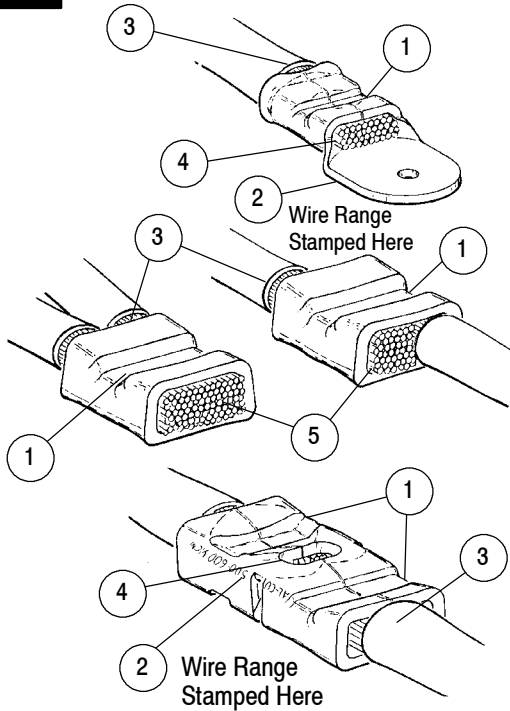

- 1 Crimps centered. Crimp may be slightly off center BUT NOT OFF END OF WIRE BARREL.
- 2 CMA of wire being used matches wire range specified for each terminal dash number.
- 3 Insulation does not enter wire barrel.
- 4 Wire is visible through inspection hole of butt splice, and is flush with or extends slightly beyond end of terminal wire barrel.
- 5 On parallel splices, bare wire ends must be flush with or extend slightly beyond end of barrel.

REJECT

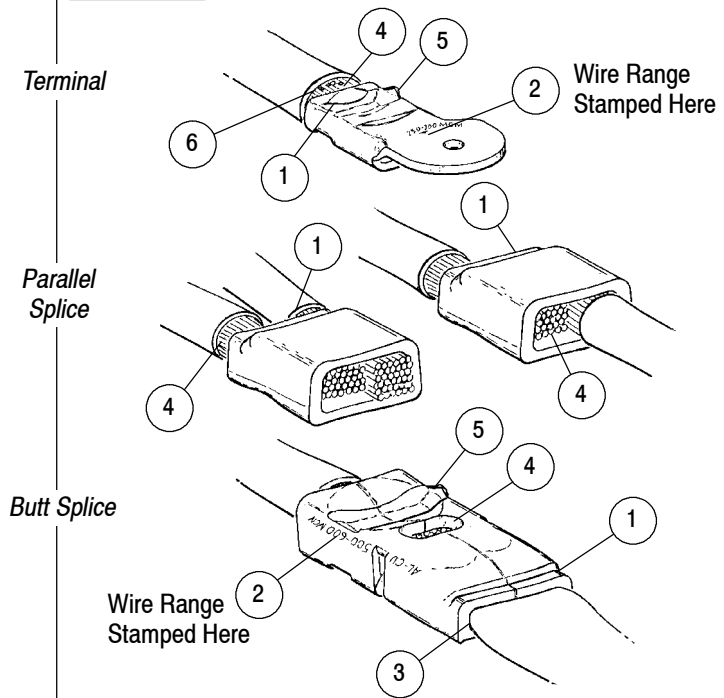

- 1 Crimped off end of splice or terminal.
- 2 CMA of wire being used does not match wire range stamped on terminal, splice, or dies.
- 3 Insulation entered barrel of terminal or splice. CHECK FOR INCORRECT STRIP LENGTH.
- 4 Wire not inserted far enough in terminal or splice. End of wire must be visible through inspection hole of butt splices, and be flush with or extend slightly beyond end of terminal wire barrel or parallel splice.
- 5 Excessive "flash" indicates wrong wire, terminal, splice, or die combination was used.
- 6 Nicked or missing strands.

Figure 5A
(Crimp Inspection Criteria for COPALUM Terminals and Splices)

HF-30 Pin and Socket Contacts

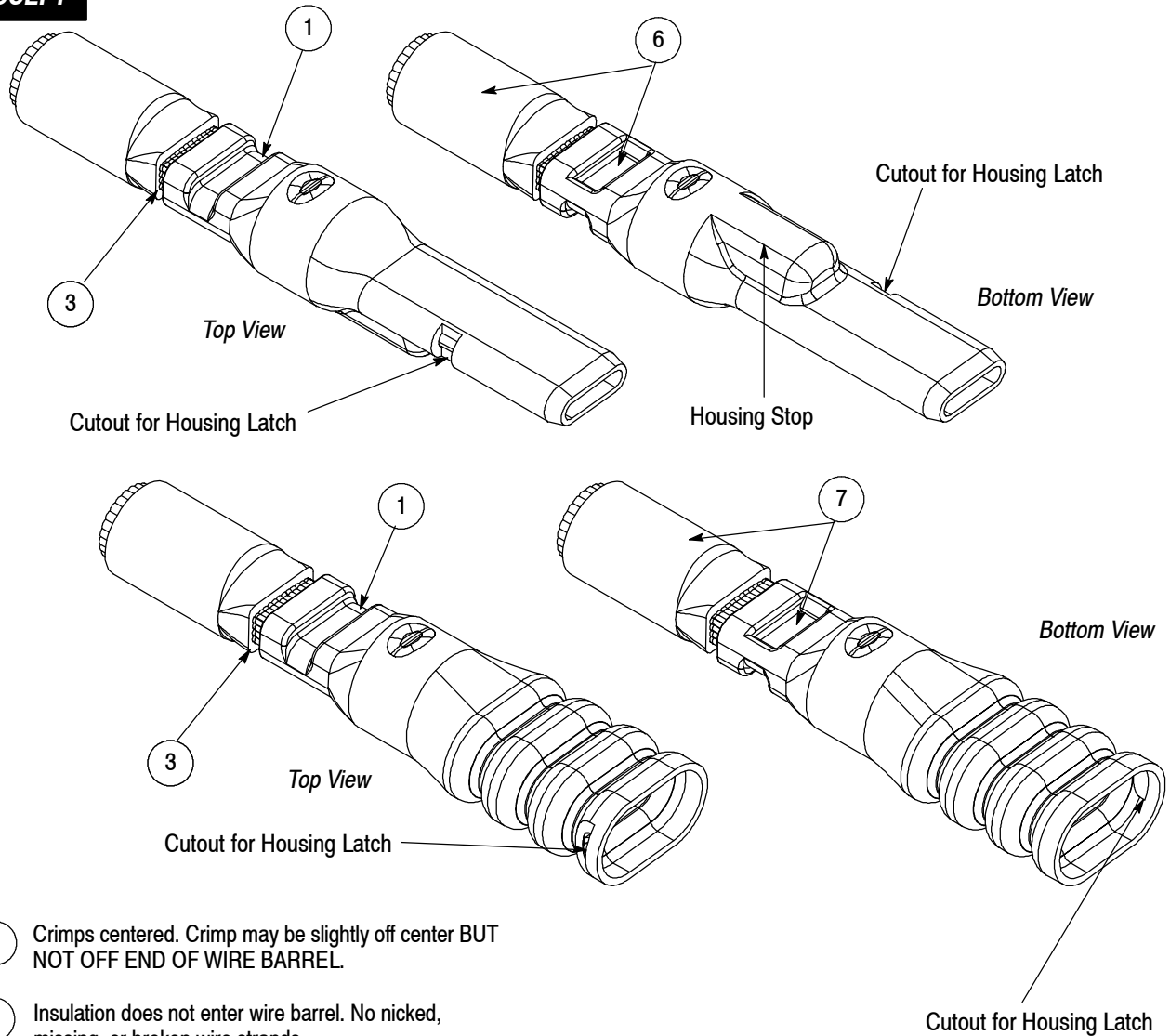
ACCEPT

- 1 Crimps centered. Crimp may be slightly off center BUT NOT OFF END OF WIRE BARREL.
- 3 Insulation does not enter wire barrel. No nicked, missing, or broken wire strands.
- 6 Crimp die embossment, and wire size agree with table in Figure 2. The verification of the correct terminal dash number used with proper crimp die and wire size must be done prior to crimping of contacts. See Paragraph 3.5.1.
- 7 Crimp die embossment, and wire size agree with table in Figure 2. The verification of the correct terminal dash number used with proper crimp die and wire size must be done prior to crimping of contacts. See Paragraph 3.5.1.

Figure 5B
(Crimp Inspection Criteria for HF-30 Pin and Socket Contacts)

5. MAINTENANCE/INSPECTION



AVOID PERSONAL INJURY; exercise extreme caution when using power unit. Avoid depressing foot switch or trigger control when installing or removing die assemblies.

Customer-replaceable parts are listed in Figure 9. A complete inventory should be stocked and controlled to prevent lost time when replacement of parts is necessary.

Crimping Die Assemblies are inspected before shipment. Tyco Electronics recommends that the die assembly be inspected immediately upon arrival at your facility to ensure that it has not been damaged during shipment.

5.1. Daily Maintenance

It is recommended that each operator of the tool be made aware of – and responsible for – the following three steps of daily maintenance:

1. Remove dust, moisture, and other contaminants with a clean brush, or a soft, lint-free cloth. Do NOT use objects that could damage the dies.
2. Make certain the dies are protected with a THIN coat of any good SAE 20 motor oil. DO NOT OIL EXCESSIVELY.



NOTE Wipe excess oil from tool, particularly from crimping area. Oil transferred from the crimping area onto certain terminations may affect the electrical characteristics of an application.

3. When the dies are not in use, mate them and store the tool in a clean, dry area.

5.2. Periodic Inspection

Tyco Electronics recommends that a maintenance and inspection program be performed periodically to ensure dependable and uniform terminations. Though recommendations call for at least one inspection a month, frequency of inspection depends on:

1. The care, amount of use, and handling of the dies.
2. The presence of abnormal amounts of dust and dirt.
3. The degree of operator skill.
4. Your own established standards.

A. Visual Inspection

1. Remove all lubrication and accumulated film by immersing the die assembly in a suitable commercial degreaser that will not affect paint or plastic material.

2. Inspect the crimp area for flattened, chipped, cracked, worn, or broken areas. If damage is evident, the dies must be replaced or repaired. Examples of possible damaged die closure surfaces are shown in Figure 6. If desired, you may return them to Tyco Electronics for evaluation and repair (see Section 6, REPAIR).

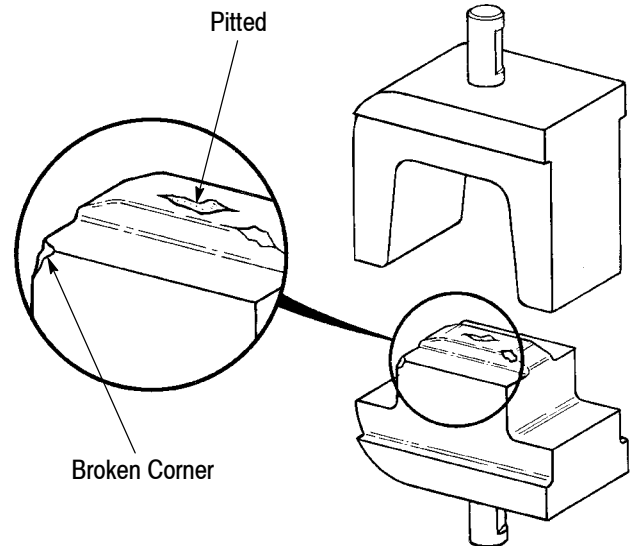

Figure 6

B. Gaging the Crimping Chamber

This inspection requires the use of a plug gage conforming to the diameters provided in Figure 7. Tyco Electronics does not manufacture or market these gages. The following procedure is recommended for inspecting the die closures.

1. Clean oil or dirt from the die closure areas, and plug gage elements.
2. Assemble and adjust dies to meet the “gage dimension” indicated in Figure 8, Detail A.
3. With dies positioned at the “gage dimension,” inspect the bar crimp closure using the proper plug gage. Align the GO element of the gage with the crimping chamber. Push the element straight into the chamber without using force. The GO element must pass completely through the crimping chamber without using force, as shown in Figure 8, Detail A.
4. Align the NO-GO element with the crimping chamber and try to insert it straight into the chamber. The NO-GO element may start entry, but must not pass through, as shown in Figure 8, Detail A.
5. With dies positioned at “gage dimension,” check the right and left rectangular crimp closures using the proper plug gage in the same manner as Steps 4 and 5; see Figure 8, Detail B.

Suggested Plug Gage Design - Bar Crimp

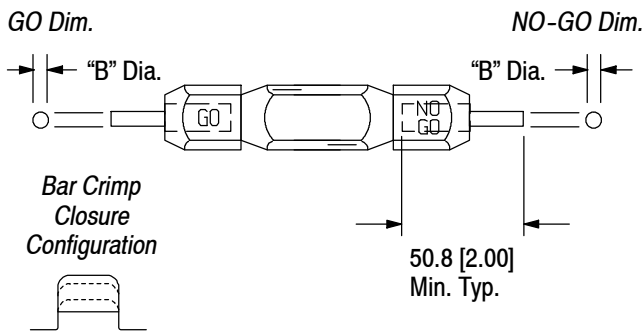

Suggested Plug Gage Design - Rectangular Crimp

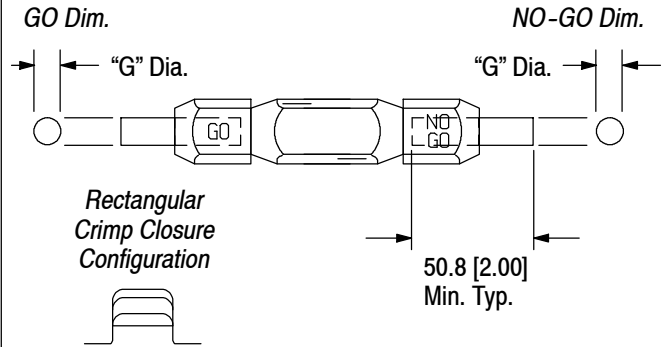

DIE SET	GAGE ELEMENT DIMENSIONS ("B" DIA)		DIE SET	GAGE ELEMENT DIMENSIONS ("G" DIA)	
	GO	NO-GO		GO	NO-GO
68034	5.512-5.519 [.2170-.2173]	5.763-5.766 [.2269-.2270]	68034	12.624-12.631 [.4970-.4973]	12.977-12.979 [.5109-.5110]
68035	6.172-6.180 [.2430-.2433]	6.424-6.426 [.2529-.2530]	68035	13.945-13.952 [.5490-.5493]	14.298-14300 [.5629-.5630]
68036	6.960-6.967 [.2740-.2743]	7.211-7.214 [.2839-.2840]	68036	15.596-15.603 [.6140-.6143]	15.949-15.951 [.6279-.6280]
68037	7.874-7.882 [.3100-.3103]	8.125-8.128 [.3199-.3200]	68037	17.526-17.534 [.6900-.6903]	17.879-17.882 [.7039-.7040]
68037-1	7.239-7.247 [.2850-.2853]	7.490-7.493 [.2949-.2950]	68037-1	16.332-16.340 [.6430-.6433]	16.685-16.688 [.6569-.6570]
68043	1.702-1.709 [.0670-.0673]	1.953-1.956 [.0769-.0770]	68043	4.1191-4.199 [.1650-.1653]	4.544-4.547 [.1789-.1790]
68044	2.007-2.014 [.0790-.0793]	2.258-2.260 [.0889-.0890]	68044	5.258-5.265 [.2070-.2073]	5.611-5.613 [.2209-.2210]
68045	2.464-2.471 [.0970-.0973]	2.715-2.718 [.1069-.1070]	68045	5.715-5.723 [.2250-.2253]	6.068-6.071 [.2389-.2390]
68046	2.718-2.725 [.1070-.1073]	2.969-2.972 [.1169-.1170]	68046	6.629-6.637 [.2610-.2613]	6.982-6.985 [.2749-.2750]
68047	3.404-3.411 [.1340-.1343]	3.655-3.658 [.1439-.1440]	68047	7.925-7.932 [.3120-.3123]	8.278-8.280 [.3259-.3260]
68048	3.835-3.843 [.1510-.1513]	4.087-4.089 [.1609-.1610]	68048	8.865-8.872 [.3490-.3493]	9.218-9.220 [.3629-.3630]
68049	4.343-4.351 [.1710-.1713]	4.595-4.597 [.1809-.1810]	68049	9.881-9.888 [.3890-.3893]	10.233-10.236 [.4029-.4030]
68050	4.8511-4.859 [.1910-.1913]	5.103-5.105 [.2009-.2010]	68050	11.201-11.209 [.4410-.4413]	11.554-11.557 [.4549-.4550]

Figure 7

If both the bar crimp and the rectangular crimp closures meet the plug gage conditions, the closures may be considered dimensionally correct and should be lubricated with a thin coat of any good SAE 20 motor oil. If the dies do NOT conform, the dies must

be replaced or repaired before returning them to service. See Section 6, REPAIR.

For additional information concerning the use of the plug gage, refer to Instruction Sheet 408-7424.

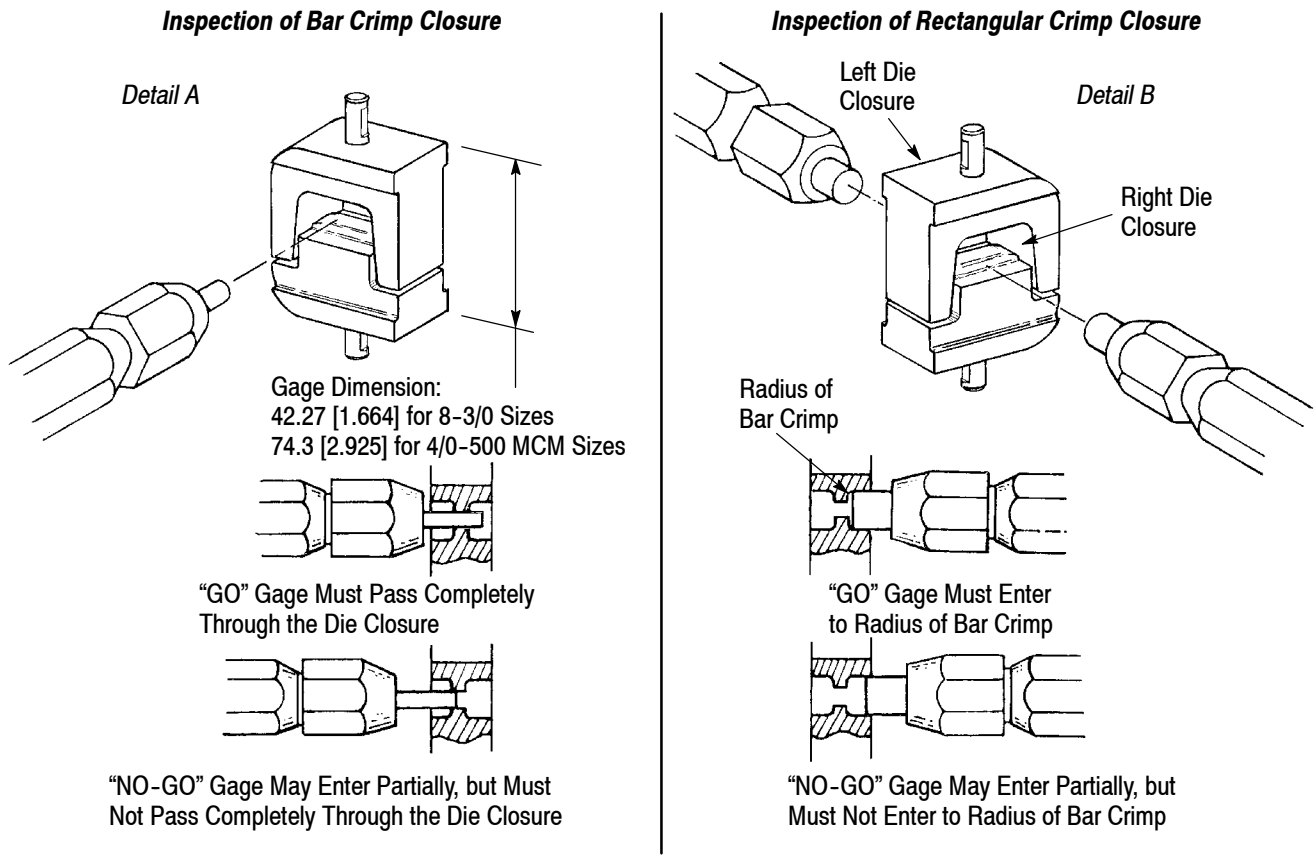

Figure 8

6. REPAIR/REPLACEMENT

Replaceable parts are listed in Figure 9. Parts other than those listed in Figure 9 should be replaced by Tyco Electronics to ensure quality and reliability of the tool. Order replacement parts through your Tyco Electronics Representative, or call 1-800-526-5142, or send a facsimile of your purchase order to 1-717-986-7605, or write to:

CUSTOMER SERVICE (38-35)
TYCO ELECTRONICS CORPORATION
P.O. BOX 3608
HARRISBURG, PA 17105-3608

For tool repair service, please contact an Tyco Electronics Representative at 1-800-526-5136.

7. REVISION SUMMARY

- Updated document to corporate requirements
- Added new part number 68037-1 to tables in Figures 1, 2, 7, and 9
- Added, deleted, or changed text in Section 2, Paragraphs 3.1.1, 3.1.2 CAUTION, 3.2 DANGER, 3.2.1, 3.2.2, and SubHeadings 3.2, 3.3, and 3.4
- Deleted old and added new artwork to Figure 2
- Added new Paragraph 3.5.1 and renumbered
- Added new Figure 4 and renumbered
- Added new callouts to Figures 1, 2B, 3, and deleted callout and added text to Figure 5B
- Combined Figures 6 and 7 and renumbered

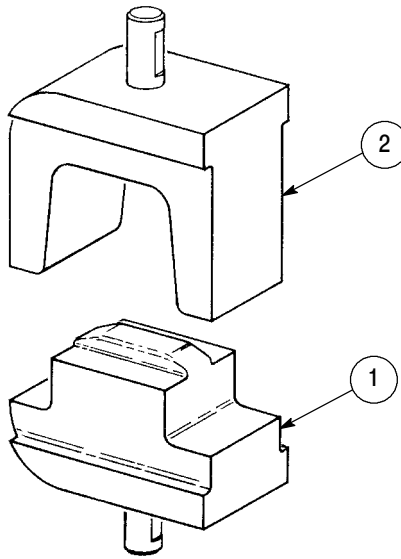

ASSEMBLY	ITEM 1 MOVING DIE (INDENTER)	ITEM 2 STATIONARY DIE (NEST)
68034	1-307586-3	1-307585-3
68035	1-307586-4	1-307585-4
68036	1-307586-5	1-307585-5
68037	1-307586-6	1-307585-6
68037-1	1-307586-7	1-307585-7
68043	307586-1	307585-1
68044	307586-2	307585-2
68045	307586-3	307585-3
68046	307586-4	307585-4
68047	307586-5	307585-5
68048	307586-6	307585-6
68049	307586-7	307585-7
68050	307586-8	307585-8

Figure 9