

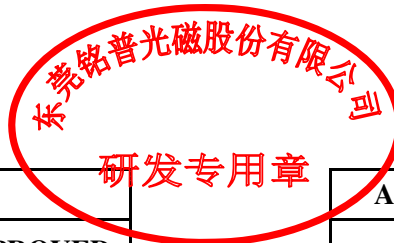

## Product Specification for Approval

WE ARE PLEASED IN SUBMITTING OUR SAMPLES WITH SPECIFICATION TO YOU FOR APPROVAL.

<b>CUSTOMER</b>	:	
<b>DESCRIPTION</b>	:	<b>100/1000 BASE-T TRANSFORMER</b>
<b>MNC P/N</b>	:	<b>G2488CE</b>
<b>VERSION</b>	:	<b>A0</b>
<b>CUSTOMER P/N</b>	:	
<b>ISSUED DATE</b>	:	<b>2020/04/27</b>
<b>PHOTO OF PRODUCT</b>	:	
<b>WEIGHT</b>	:	<b>1.60g</b>
<b>MADE IN</b>	:	<b>CHINA</b>



APPROVED BY MNC			APPROVED BY CUSTOMER
PREPARED BY	CHECKED BY	APPROVED BY	SIGNATURE OR STAMP
			

1. PLEASE SEND BACK US A COPY OF THE SPECIFICATION WITH YOUR STAMP OR SIGNATURE ONCE THE SAMPLES APPROVED.
2. IT WILL BE DEEMED THE SAMPLES TO BE APPROVED IF NO FEEDBACK.

东莞铭普光磁股份有限公司  
 Add: Shipai Town, Dongguan City, Guangdong Province, China

TEL: +86-769-86921000  
 FAX: +86-769-81701563



**SPECIFICATION**

**Part No. G2488CE**

**A. MECHANICAL :**

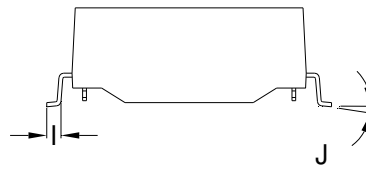
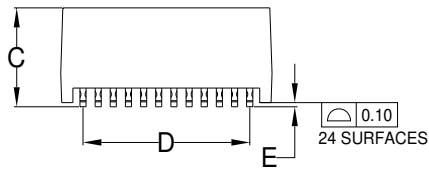
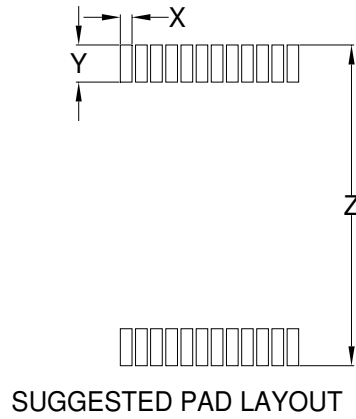
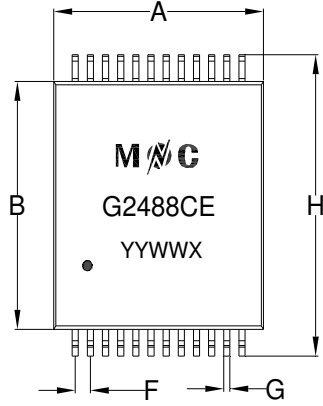

Note: Laser printing marking

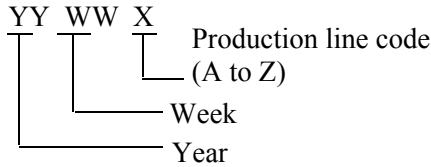

- 1. UNITS: mm/inch.
- 2. UNLESS OTHERWISE SPECIFIED ALL TOLERANCES ARE: TYPICAL
- 3. PIN LENGTH DON'T INCLUDE SOLDER POINT

DIM	MILLIMETERS			INCHES		
	MIN	NOM	MAX	MIN	NOM	MAX
A	13.20	13.70	14.20	0.520	0.539	0.559
B	14.80	15.30	15.80	0.583	0.602	0.622
C	/	/	6.70	/	/	0.264
D	/	10.89	/	/	0.429	/
E	0.10	0.25	0.40	0.004	0.010	0.016
F	/	0.99	/	/	0.039	/
G	/	0.40	/	/	0.016	/
H	18.10	18.60	19.10	0.713	0.732	0.752
I	/	0.90	/	/	0.035	/
J	0°	/	8°	0°	/	8°
X	/	0.76	/	/	0.030	/
Y	/	2.29	/	/	0.090	/
Z	/	19.60	/	/	0.772	/

**SPECIFICATION**

**Part No. G2488CE**

**B. SCHEMATIC :**

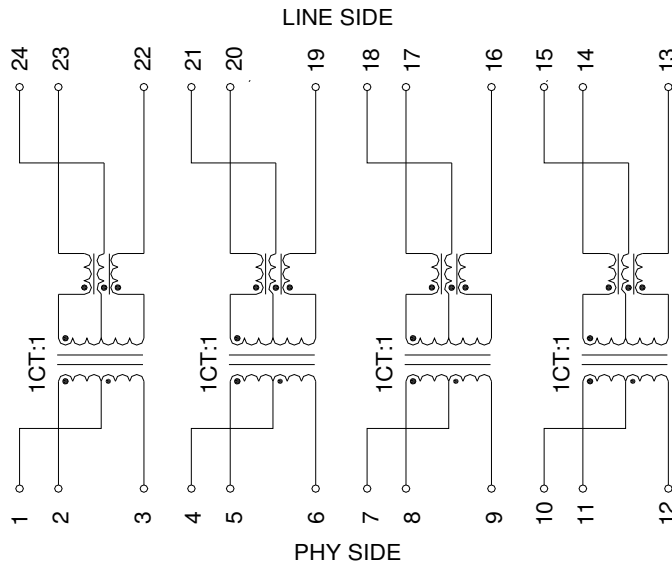

**C. ELECTRICAL SPECIFICATION @25°C**

ITEM	SPECIFICATION	TEST CONDITION	TEST EQUIPMENT
INDUCTANCE :	350uH MIN.	100KHz 0.2V 8mA DC Bias	TH2819XB OR EQU.
LEAKAGE INDUCTANCE :	0.50uH MAX.	100KHz 0.2V	TH2819XB OR EQU.
INTERWINDING CAPACITANCE :	25pF TYP.	100KHz 0.2V	TH2819XB OR EQU.
DC RESISTANCE :	1.2Ω MAX.	AT 25 °C	TOS 8020 OR EQU.
TURNS RATIO :	1CT:1CT±5%		TH2819XB OR EQU.
POLARITY :	2-23,5-20,8-17, 11-14 IN-PHASE		
INSERTION LOSS :	-1.1dB MAX.	0.5-100 MHz	E5061A OR EQU.
RETURN LOSS :	-18dB MIN.	0.5-40 MHz	E5061A OR EQU.
	-12+20log(f/80)dB MIN.	40.1-100 MHz	
CROSS TALK :	-35dB MIN.	0.5-40 MHz	E5061A OR EQU.
	-33+20*log(f/50)dB MIN.	40.1-100 MHz	
CMRR :	-30dB MIN.	0.5-100 MHz	E5061A OR EQU.
ISOLATION HI-POT :PRI TO SEC	1500VAC	1mA,60S	7152AB OR EQU.
	1650VAC	1mA,6S	
OPERATING TEMPERATURE	-40°C TO 85°C		

**PACKAGE**

**Part No. G2488CE**

**D. PACKING:**

**a. PACKAGING AS BELOW (ONLY FOR A REFERENCE):**

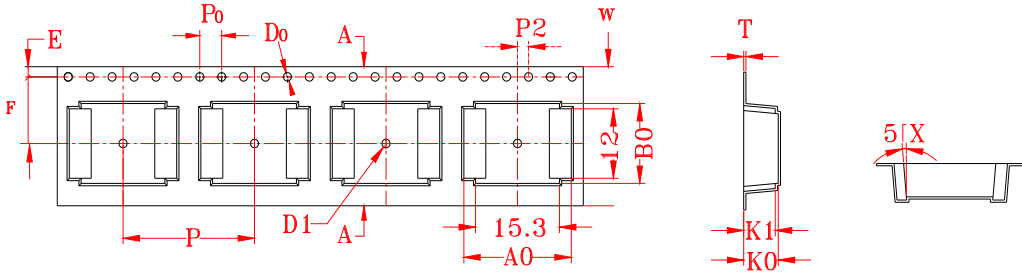

ITEM	W	A <sub>0</sub>	B <sub>0</sub>	K <sub>0</sub>	K <sub>1</sub>	P	F	E	D <sub>0</sub>	D <sub>1</sub>	P <sub>0</sub>	P <sub>2</sub>	T
DIM	24.0 <sup>+0.30</sup> <sub>-0.30</sub>	19.6 <sup>+0.10</sup> <sub>-0.10</sub>	13.8 <sup>+0.10</sup> <sub>-0.10</sub>	6.30 <sup>+0.10</sup> <sub>-0.10</sub>	5.75 <sup>+0.10</sup> <sub>-0.10</sub>	24.0 <sup>+0.10</sup> <sub>-0.10</sub>	11.5 <sup>+0.10</sup> <sub>-0.10</sub>	1.75 <sup>+0.10</sup> <sub>-0.10</sub>	1.50 <sup>+0.10</sup> <sub>-0.10</sub>	1.50 <sup>+0.10</sup> <sub>-0.00</sub>	4.00 <sup>+0.10</sup> <sub>-0.10</sub>	2.00 <sup>+0.10</sup> <sub>-0.10</sub>	0.40 <sup>+0.05</sup> <sub>-0.05</sub>
ALTERNATE													

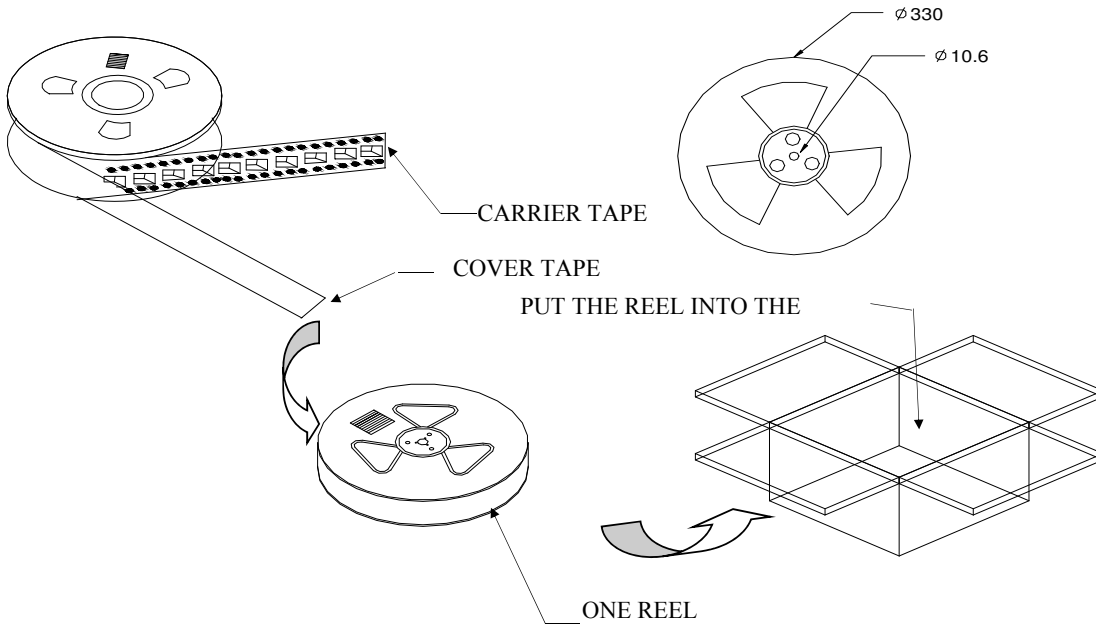

**b. Q'TY:**

400 PCS PER REEL  
6 REELS PER CARTON  
2400 PCS PER CARTON

**c. LABEL:**



**REMARK:**

ABOVE PACKING IS FOR YOUR REFERENCE ONLY, WHICH MIGHT BE CHANGED WITHOUT NOTICE.

**MATERIAL LIST**
**Part No. G2488CE**
**E.BOM**

<b>MATERIAL LIST</b>					
<b>NO.</b>	<b>ITEM</b>	<b>MATERIAL</b>	<b>RATING</b>	<b>SUPPLIER OF MATERIAL</b>	<b>UL</b>
<b>1</b>	<b>CORE</b>	<b>Mn-Zn</b>	-----	<b>YEAN SHING</b>	<b>N/A</b>
			-----	<b>ZHONGSHAN CRC ELECTRONICS FACTORY</b>	<b>N/A</b>
		<b>Ni-Zn</b>	-----	<b>YEAN SHING</b>	<b>N/A</b>
			-----	<b>ZHONGSHAN CRC ELECTRONICS FACTORY</b>	<b>N/A</b>
<b>2</b>	<b>COPPER WIRE</b>	<b>QPN180</b>	<b>180℃</b>	<b>ZHUHAI SUNTEK WIRE CO.,LTD</b>	<b>E234867</b>
		<b>Polysol 180</b>	<b>180℃</b>	<b>ELEKTRISOLA(MALAYSIA) SDN.BHD.</b>	<b>E258243</b>
<b>3</b>	<b>CASE</b>	<b>WH-9100</b>	<b>V-0</b>	<b>WAH HONG INDUSTRIAL CORP</b>	<b>E150608</b>
<b>4</b>	<b>PIN</b>	<b>C5191</b>	-----	<b>SHENZHEN MINGSCHIN INDUSTRIAL MATERIAL CO.,LTD</b>	<b>N/A</b>

**RECOMMENDED SOLDERING PROFILE**

**Part No. G2488CE**

**a. RECOMMENDED REFLOW SOLDERING PROFILE:**

below content is only for your reference

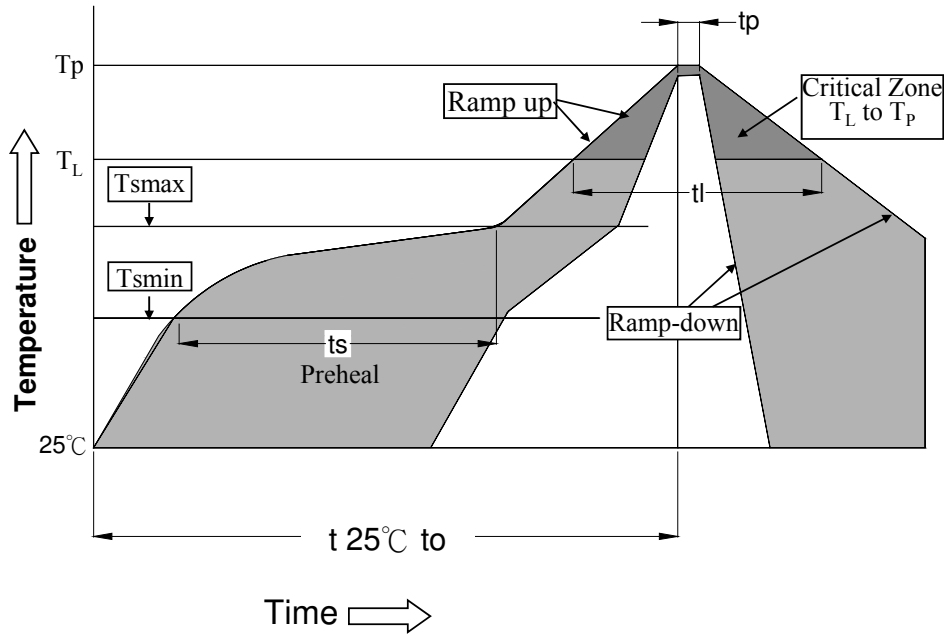

$T_L = 217^\circ\text{C}$

$T_p = 245^\circ\text{C}$

$t_s = 60-180\text{s}$      $T_s \text{ max} = 200^\circ\text{C}$      $T_s \text{ min} = 150^\circ\text{C}$

$t_l = 60-150\text{s}$      $t_p = 20-40\text{s}$      $T_{25^\circ\text{C to peak}} = 8\text{min max}$

Ramp up rate =  $3^\circ\text{C/s max}$

Ramp down rate =  $6^\circ\text{C/s max}$

\*RoHS Compliant

\*Solder Paste SAC 305 Sn 96.5/Ag 3.0/Cu 0.5

\*Silkscreen thickness: 0.15mm Min

**b. MOISTURE SENSITIVE LEVEL:**

b.1. LEVEL: 1

b.2. SHELF LIFE: UNLIMITED

b.3. STORAGE CONDITION:  $\cong 30^\circ\text{C}/85\% \text{ RH}$