

Material :

- * Body: High temperature plastic UL 94V-0, Color Nature
- * Cover: High temperature plastic UL 94V-0, Color Black
- * Contact: Phosphor Bronze
- * Fixed tab: Brass with 2.50μm(100μ") Min. Matte Tin Plated over 1.02μm(40μ") Min. Nickel

Ordering Code

CF34 04 2 D 0 R * -10 -NH
 ① ② ③ ④ ⑤ ⑥ ⑦ ⑧ ⑨

- ① Series No.
- ② No. of Circuits
- ③ Plating code: 1 = 2.50μm(100μ") Min. Matte Tin plated over 1.27μm(50μ") Min. Nickel
 2 = 0.02μm(0.8μ") Min. Gold Flash Plating on Contact area and Solderails, 1.27μm(50μ") Nickel Underplating over all
- ④ Contact style: D= Downside contact
- ⑤ 0= Color Nature
- ⑥ Packing: T= Tube packing
 R= Tape & Reel packing
- ⑦ Opeion: 0= Without Mylar (Standard)
 M= With Mylar
- ⑧ -10= Pitch 1.0mm
- ⑨ -NH= For Lead Free IR Processed and Halogen Free

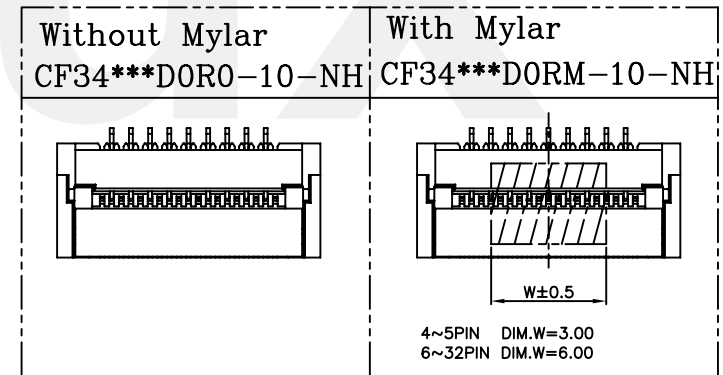
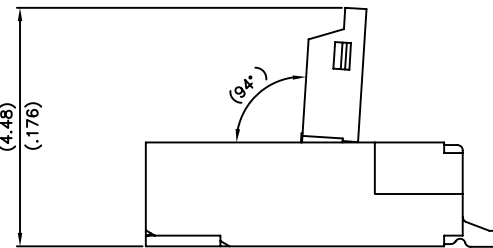
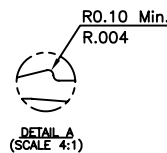
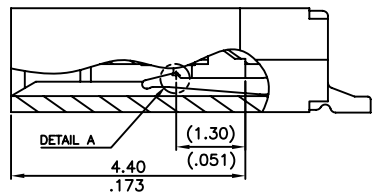
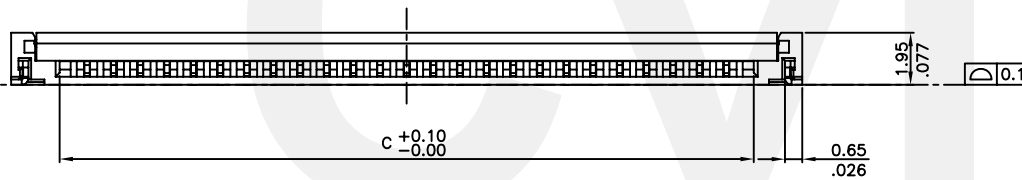
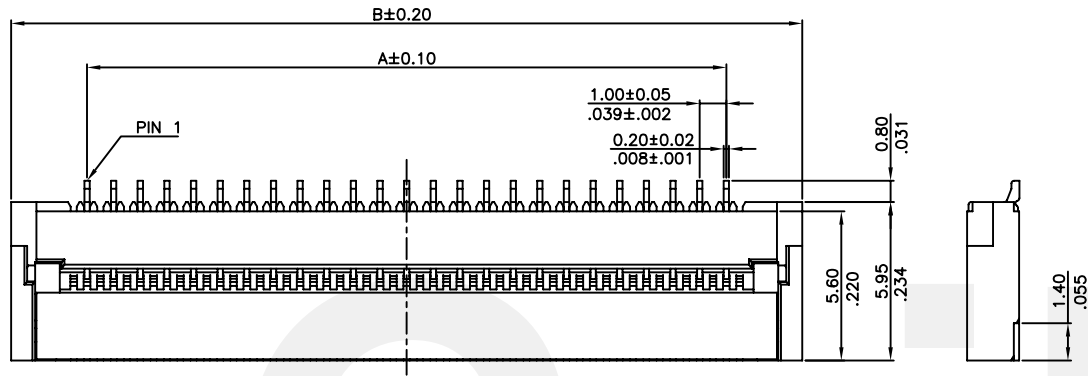

SECTION A-A
(SCALE 2:1)

OPENED STATE
(SCALE 2:1)

Halogen-Free

Lead Free Process

RoHS compliant

CIVILUX CORP
 2014.11.14
 ISSUED

4					DATE	UNIT: mm / inch	TITLE: 1.00mm(.039") ZIF FFC/FPC ONE-TOUCH CONNECTOR	瀚荃股份有限公司 CviLux Corporation
3				DRAWN BY: Claire	11/10-14"	TOLERANCE UNLESS OTHERWISE SPECIFIED	MATERIAL:	
2				ENGINEER: Francis	11/10-14"	.X ± 0.20/.008 X* ±	FINISH:	DRAWING NO. CF3402SC
1	Claire	11/6-14"	ECRT214039/ECNT214064	CHECKED BY: Jerry	11/10-14"	.XX ± 0.15/.006 X* ± 1'		SCALE 5 / 1
SYM	NAME	DATE	REVISIONS	APPROVED BY: Scott	11/10-14"	.XXX ± .XX ±		SHEET 1 OF 3

(N) NO. of CONTACTS	DIMENSIONS					
	A		B		C	
4	3.00	(.118)	8.70	(.343)	5.06	(.199)
5	4.00	(.157)	9.70	(.382)	6.06	(.239)
6	5.00	(.197)	10.70	(.421)	7.06	(.278)
7	6.00	(.236)	11.70	(.461)	8.06	(.317)
8	7.00	(.276)	12.70	(.500)	9.06	(.357)
9	8.00	(.315)	13.70	(.539)	10.06	(.396)
10	9.00	(.354)	14.70	(.579)	11.06	(.435)
11	10.00	(.394)	15.70	(.618)	12.06	(.475)
12	11.00	(.433)	16.70	(.657)	13.06	(.514)
13	12.00	(.472)	17.70	(.697)	14.06	(.554)
14	13.00	(.512)	18.70	(.736)	15.06	(.593)
15	14.00	(.551)	19.70	(.776)	16.06	(.632)
16	15.00	(.591)	20.70	(.815)	17.06	(.672)
17	16.00	(.630)	21.70	(.854)	18.06	(.711)
18	17.00	(.669)	22.70	(.894)	19.06	(.750)
19	18.00	(.709)	23.70	(.933)	20.06	(.790)
20	19.00	(.748)	24.70	(.972)	21.06	(.829)
21	20.00	(.787)	25.70	(1.012)	22.06	(.869)
22	21.00	(.827)	25.70	(1.051)	23.06	(.908)
23	22.00	(.866)	27.70	(1.091)	24.06	(.947)
24	23.00	(.906)	28.70	(1.130)	25.06	(.987)
25	24.00	(.945)	29.70	(1.169)	26.06	(1.026)
26	25.00	(.984)	30.70	(1.209)	27.06	(1.065)
27	26.00	(1.024)	31.70	(1.248)	28.06	(1.105)
28	27.00	(1.063)	32.70	(1.287)	29.06	(1.144)
29	28.00	(1.102)	33.70	(1.327)	30.06	(1.183)
30	29.00	(1.142)	34.70	(1.366)	31.06	(1.223)
31	30.00	(1.181)	35.70	(1.406)	32.06	(1.262)
32	31.00	(1.220)	36.70	(1.445)	33.06	(1.302)

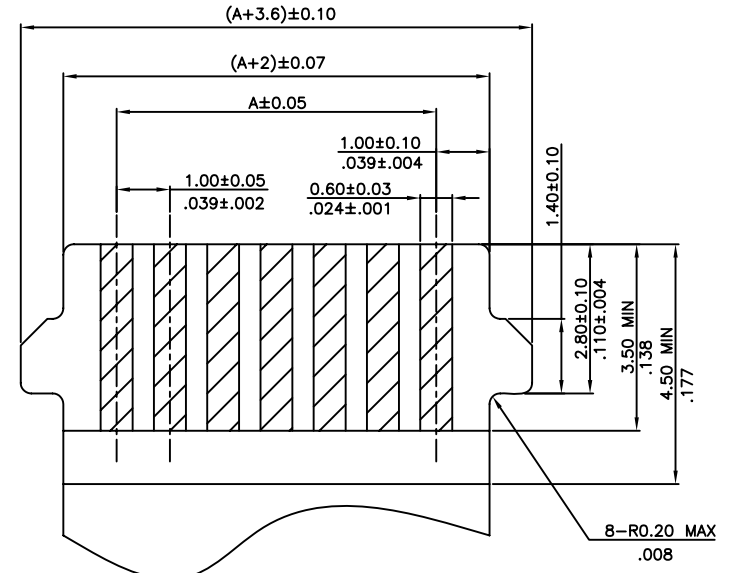

Accommodated FFC/FPC
(THICKNESS:0.3±0.03)

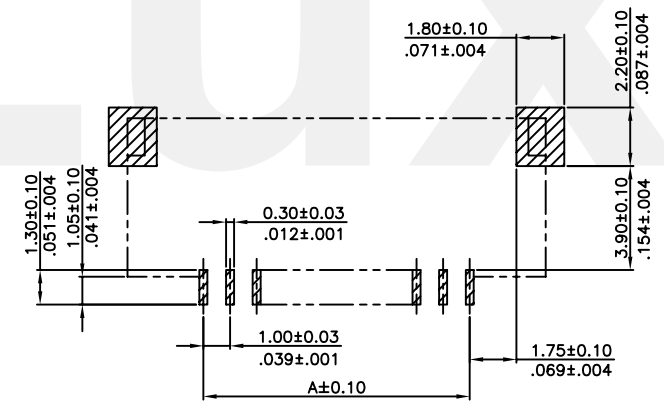

Recommended P.C. Board Layout

RoHS Compliant

CVILUX CORP
2014.11.14
ISSUED

4					DATE	UNIT: mm / inch	TITLE: 1.00mm(.039") ZIF FFC/FPC ONE-TOUCH CONNECTOR	 瀚荃股份有限公司 CviLux Corporation
3				DRAWN BY: Claire	11/10-14"	TOLERANCE UNLESS OTHERWISE SPECIFIED	MATERIAL:	
2				ENGINEER: Francis	11/10-14"	.X ± 0.20/.008 X" ±	FINISH:	DRAWING NO. CF3402SC
1	Claire	11/6-14"	ECRT214039/ECNT214064	CHECKED BY: Jerry	11/10-14"	.XX ± 0.15/.006 X" ± 1'		SCALE 5 / 1
SYM	NAME	DATE	REVISIONS	APPROVED BY: Scott	11/10-14"	.XXX ± XX" ±		SHEET 2 OF 3

Notes:

1. 10 sprocket hole pitch cumulative tolerance ± 0.2
2. Camber not to exceed 1mm in 100mm.
3. Material: Advantek Polystyrene.
4. Pocket position relative to sprocket hole measured as true position of pocket, not pocket hole.
5. All dimensions meet EIA-481 requirements.
6. Quantity: 2000 PCS/REEL

Circuits	Dimension					Packing (Reel/Caton)
	E	F	W1	W2	W3	
4-11	24.0(.945)	11.50(.453)	24.5(.965)	30.5(1.200)	24.5(.965)	9
12-15	32.0(1.260)	14.20(.559)	32.5(1.280)	38.5(1.516)	32.5(1.280)	7
16-27	44.0(1.732)	20.20(.795)	44.5(1.752)	50.5(1.988)	44.5(1.752)	5
28-32	56.0(2.205)	26.2(1.031)	56.5(2.224)	62.5(2.460)	56.5(2.224)	4

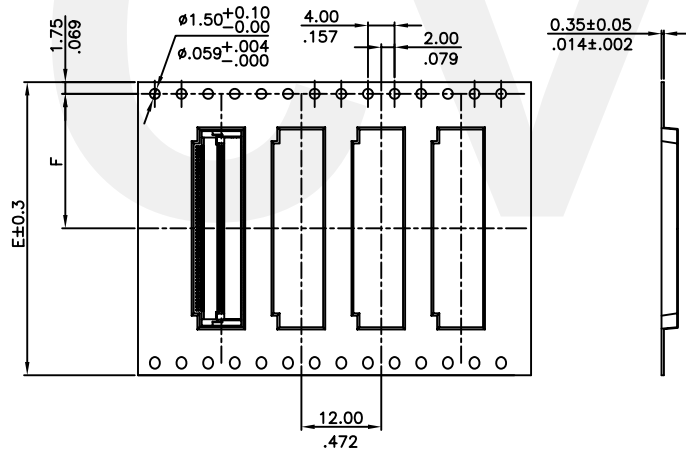
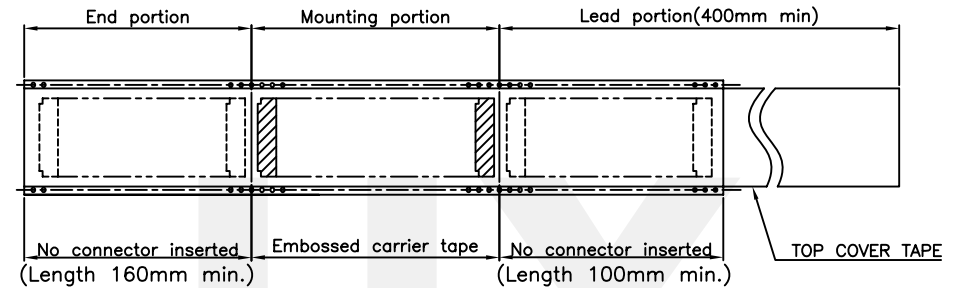
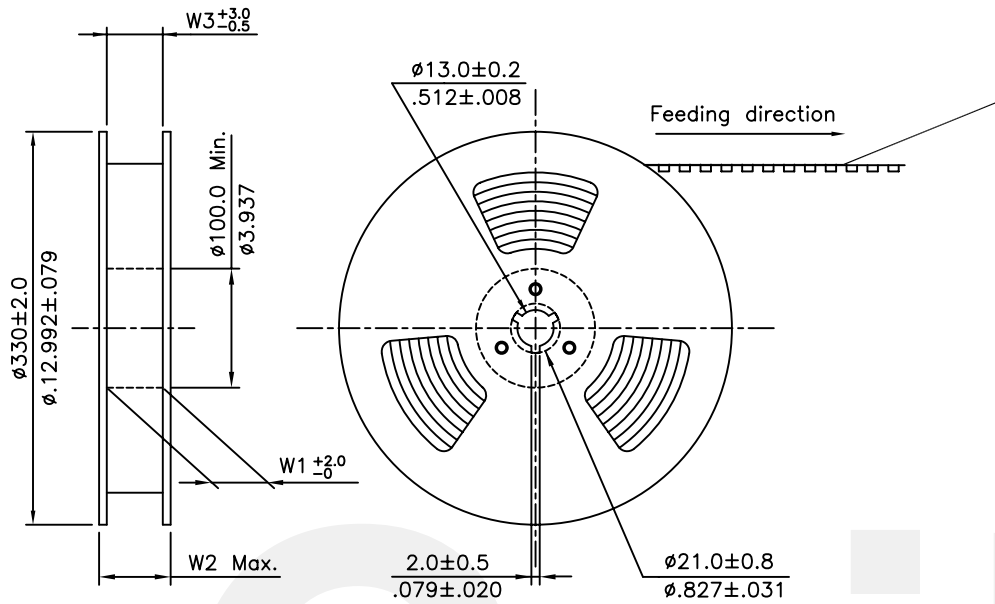

WIDTH : 32, 44, 56 mm Carrier
(SCALE 1:4)

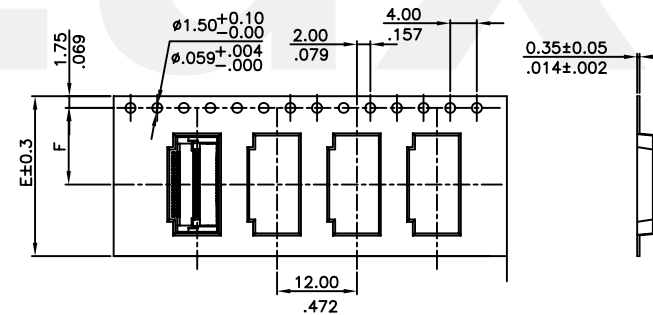

WIDTH : 24 mm Carrier
(SCALE 1:4)

RoHS Compliant

CIVILUX CORP
2014.11.14
ISSUED

4					DATE	UNIT: mm / inch	TITLE: 1.00mm(.039") ZIF FFC/FPC ONE-TOUCH CONNECTOR	 瀚荃股份有限公司 CviLux Corporation	
3					DRAWN BY: Claire	TOLERANCE UNLESS OTHERWISE SPECIFIED	MATERIAL:		
2					ENGINEER: Francis	.X ± 0.20/.008 X* ±	FINISH:	DRAWING NO. CF3402SC	
1	Claire	11/6-14"	ECRT214039/ECNT214064	CHECKED BY: Jerry	11/10-14"	.XX ± 0.15/.006 X* ± 1"		DRAWING NO. CF3402SC	PART NO. CF34***D0**-10-NH
SYM	NAME	DATE	REVISIONS	APPROVED BY: Scott	11/10-14"	.XXX ± .XX ±	SCALE	5 / 1	SHEET 3 OF 3