

Description

The DIODES™ ZXBM5408Q is a protected H-Bridge driver designed specifically for automotive manual headlight beam control and industrial servo control applications with DC-brush motor loads. The integrated full-bridge driver output stage is composed of high-current, low- $R_{DS(on)}$ H-bridge MOSFETs to maximize efficiency.

To simplify the circuit design and minimize external components, the device integrates voltage and temperature compensated internal references, amplifiers, and output H-bridge power switches with low $R_{DS(on)}$.

For system flexibility, the servo control forward and reverse hysteresis, deadband, and angle amplification are easily programmable by external resistors.

To help protect the motor coil, the ZXBM5408Q provides fault condition protection, such as RANGE input short to GND, short-to-supply voltage, or broken wires, by stopping the motor and disconnecting the output stage. In case of supply undervoltage and overvoltage, the device shuts down the output drive to help prevent overvoltage stress on the coil. The overcurrent protection monitors the output current and shuts down the outputs stage with periodic retry to help protect the coil from device burnout. Overtemperature shutdown provides thermal protection for the device.

The ZXBM5408Q is available in the industry standard PDIP-8 (Type A1) and SO-14 (Type A1) packages and is qualified to AEC-Q100 Grade 1 and is automotive compliant supporting PPAPs.

Features

- Servo DC Motor Drive
- Wide Operating Voltage Range: 8V to 18V
- Built-In H-Bridge with Low $R_{DS(on)}$ Resistance
- Output Drive Current capability of 0.8A (Peak Current of 1.5A)
- Fault Protection—RANGE Short to GND, Supply or Broken Wires
- Overvoltage and Undervoltage Shutdown
- Overcurrent Protection
- Thermal Protection
- Green Molding in PDIP-8 (Type A1) and SO-14 (Type A1) packages
- **Totally Lead-Free & Fully RoHS Compliant (Notes 1 & 2)**
- **Halogen and Antimony Free. "Green" Device (Note 3)**
- **The ZXBM5408Q is suitable for automotive applications requiring specific change control; this part is AEC-Q100 qualified, PPAP capable, and manufactured in IATF 16949 certified facilities. <https://www.diodes.com/quality/product-definitions/>**

- Notes:
1. No purposely added lead. Fully EU Directive 2002/95/EC (RoHS), 2011/65/EU (RoHS 2) & 2015/863/EU (RoHS 3) compliant.
 2. See <https://www.diodes.com/quality/lead-free/> for more information about Diodes Incorporated's definitions of Halogen- and Antimony-free, "Green" and Lead-free.
 3. Halogen- and Antimony-free "Green" products are defined as those which contain <900ppm bromine, <900ppm chlorine (<1500ppm total Br + Cl) and <1000ppm antimony compounds.

Pin Assignments

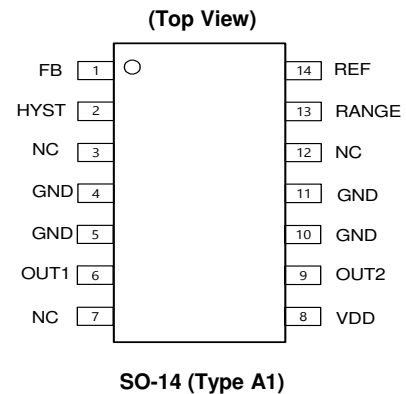
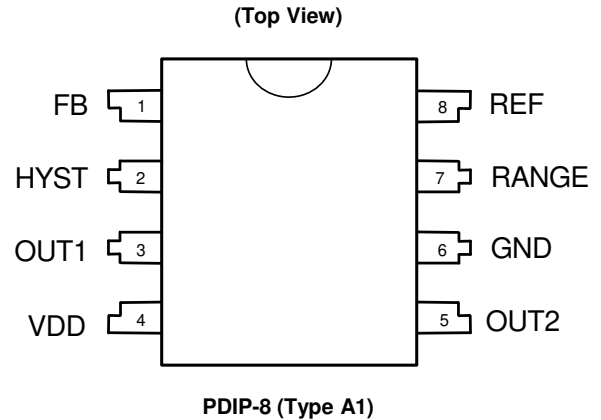

Applications

- Automotive Headlight Position Servo Motor
- 8V/12V/18V Servo DC Motors

Mechanical Data

- Moisture Sensitivity: Level 1 per JSD-020
- Terminal Finish – Matte Tin Plated Leads, Solderable per JEDEC-J-STD-002.
- Weight: ZXBM5408Q-N-U 0.496 grams (Approximate)
ZXBM5408Q-S14-13 0.150 grams (Approximate)

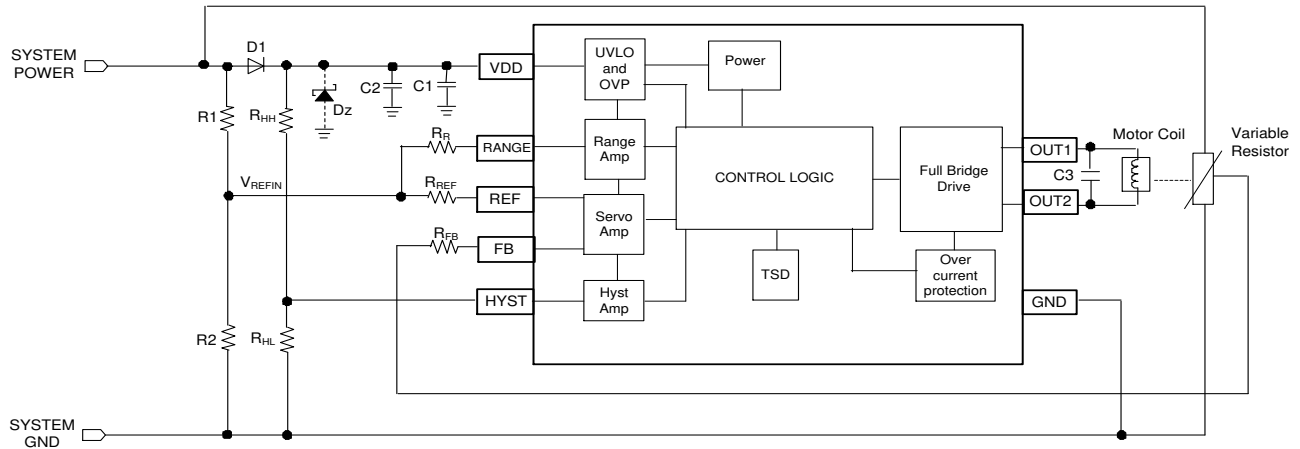
Typical Applications Circuit (Notes 4, 5, 6, and 7)

- Notes:
- The C1 capacitor is for power stabilization and to strengthen the noise immunity, and the recommended value is 100nF. The capacitor is placed next to the VDD pin. The value of the capacitor can be optimized depending on the motor current. The value of C1 must be checked in the motor design in its operating conditions if reduced from the recommended value.
 - The C2 capacitor is for power supply filtering, and the recommended value is 47 μ F to 100 μ F. C3 is output motor noise decoupling capacitor, and the recommended value is 100nF (range of 10nF to 100nF). If strengthening OCP short function (O1 and O2 short directly), the recommended value of C2 is 10 μ F (range of 10 μ F to 20 μ F) for SMD type.
 - The resistor values R1 and R2 define the V_{REFIN} . The resistors R_{HH} and R_{HL} define the hysteresis window.
 - Diode D1 is for the reverse connection protection. The zener diode Dz is used to clamp the regenerative voltage spike from the motor operation to a safe level when reverse blocking diode D1 is used. If a reverse blocking diode is not used, the use of zener clamp Dz depends on the supply voltage capability to effectively sink the regenerative energy and voltage spike.

Pin Descriptions
1. Package Type: PDIP-8 (Type A1)

Pin Number	Pin Name	Description
1	FB	Position Feedback Input: Voltage Input
2	HYST	Hysteresis I/O
3	OUT1	Output1 Drive Sourcing & Sinking Pin
4	VDD	Power Supply Input Pin
5	OUT2	Output2 Drive Sourcing & Sinking Pin
6	GND	Ground Pin
7	RANGE	Range Input
8	REF	Reference Input

2. Package Type: SO-14 (Type A1)

Pin Number	Pin Name	Description
1	FB	Position Feedback Input: Voltage Input
2	HYST	Hysteresis I/O
4, 5, 10, 11	GND	Ground pin
6	O1	Output drive sourcing & sinking pin
3, 7, 12	NC	No Connection
8	VDD	Power supply input pin
9	OUT2	Output2 drive sourcing & sinking pin
13	RANGE	Range Input
14	REF	Reference Input

Functional Block Diagram

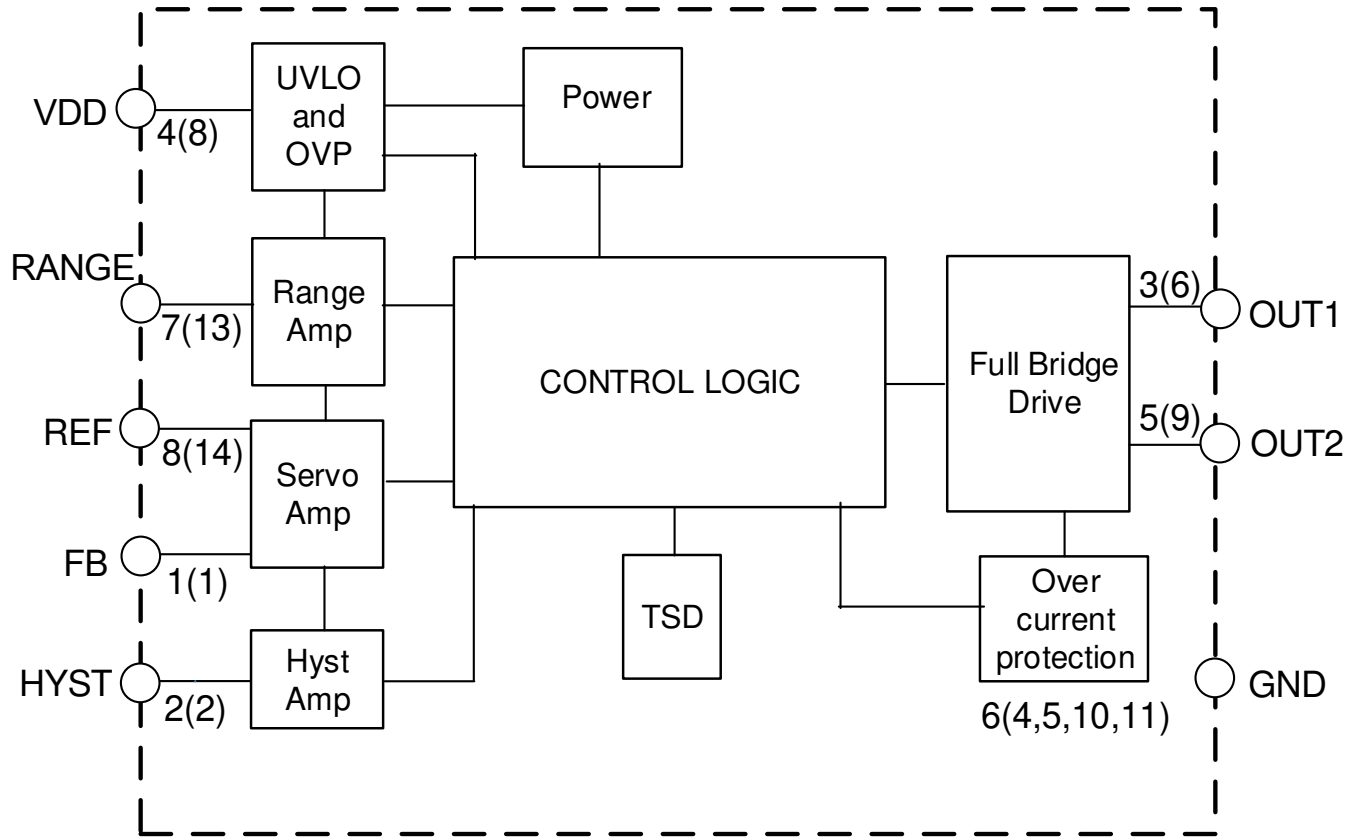

A(B)
A for PDIP-8 (Type A1)
B for SO-14 (Type A1)

Absolute Maximum Ratings (Note 8) @ $T_A = +25^{\circ}\text{C}$, unless otherwise specified.)

Symbol	Characteristics	Rating	Unit	
V_{DD_MAX}	Maximum Supply Voltage (Note 9)	45	V	
$V_{DD_REVERSE}$ $V_{REVERSE}$	Reverse Voltage on VDD and All Pins	-0.3	V	
V_{FB_MAX} V_{HYST_MAX} V_{REF_MAX}	Maximum Voltage on FB, HYST, REF Pins	20	V	
V_{RANGE_MAX}	Maximum Voltage on RANGE Pin	20	V	
$V_{FB_REVERSE}$ $V_{REF_REVERSE}$ $V_{HYST_REVERSE}$ $V_{RANGE_REVERSE}$	Reverse Supply Voltage on All Pins	-0.3	V	
I_{FB_MAX}	Maximum Current on FB Pin	± 6	mA	
I_{HYST_MAX}	Maximum Current on HYST Pin	± 6	mA	
I_{REF_MAX}	Maximum Current on REF Pin	± 6	mA	
I_{RANGE_MAX}	Maximum Current on RANGE Pin	± 6	mA	
P_D	Power Dissipation (Note 10)	PDIP-8 (Type A1) (Note 11)	1.61	W
		SO-14 (Type A1) (Note 12)	1.66	W
T_{STG}	Storage Temperature Range	-65 to +150	$^{\circ}\text{C}$	
T_J	Maximum Junction Temperature	+150	$^{\circ}\text{C}$	
ESD HBM	Human Body Model ESD Capability	PDIP-8 (Type A1)	8	kV
		SO-14 (Type A1)	3.5	
CDM	Charged Device Model (CDM)	PDIP-8 (Type A1)	1.5	kV
		SO-14 (Type A1)	1.5	

- Notes:
- Stresses greater than the *Absolute Maximum Ratings* specified above can cause permanent damage to the device. These are stress ratings only; functional operation of the device at these or any other conditions exceeding those indicated in this specification is not implied. Device reliability may be affected by exposure to absolute maximum rating conditions for extended periods of time.
 - The absolute maximum V_{DD} of 45V is a transient stress rating and is not meant as a functional operating condition. It is not recommended to operate the device at the absolute maximum rated conditions for any period of time.
 - For thermal de-rating curves under different PCB size and layout conditions, see *Thermal Performance* section.
 - PDIP-8 (Type A1) soldered to minimum recommended landing pads (see *Package Outline Dimensions* section) on 2" x 2" two-layer 2oz.copper FR-4 PC (1.6mm thickness) .See *Thermal Performance* section.
 - SO-14 (Type A1) soldered to minimum recommended landing pads (see *Package Outline Dimension* section) on 2" x 2" two-layer 2oz.copper FR4 PCB (1.6mm thickness) . See thermal performance section.

Recommended Operating Conditions

Symbol	Characteristic	Conditions	Min	Max	Unit
V_{DD}	Supply Voltage	Operating	8	18	V
T_A	Operating Ambient Temperature Range	Operating	-40	+125	$^{\circ}\text{C}$
T_J	Operating Junction Temperature Range	Operating	-40	+150	$^{\circ}\text{C}$

Electrical Characteristics (Note 13) (@ $T_A = -40^{\circ}\text{C}$ to $+125^{\circ}\text{C}$, $V_{DD} = 8\text{V}$ to 18V , unless otherwise specified.)

Symbol	Characteristics	Conditions	Min	Typ	Max	Unit
I_{DD}	Supply Current (Excluding Load Current)	No Load	—	1.45	2.5	mA
V_{UVLO_ON}	Under Voltage Protection Release Threshold	Voltage Increasing	—	7.4	8	V
V_{UVLO_OFF}	Under Voltage Protection Threshold for Shutdown to Standby Mode	Voltage Decreasing	6.3	6.9	—	V
V_{OVP_ON}	Over Voltage Protection Threshold for Shutdown to Standby Mode	Voltage Increasing	18.5	20.5	23	V
V_{OVP_OFF}	Over Voltage Release Threshold	Voltage Decreasing	17.5	20	22	V
V_{OH}	Output Voltage High	$I_{OUT} = 800\text{mA}$	$V_{DD} - 1.66$	$V_{DD} - 0.86$	—	V
		$I_{OUT} = 500\text{mA}$	$V_{DD} - 1.05$	$V_{DD} - 0.54$	—	V
V_{OL}	Output Voltage Low	$I_{OUT} = 800\text{mA}$	—	0.56	1.12	V
		$I_{OUT} = 500\text{mA}$	—	0.35	0.7	V
R_{ON_TOTAL}	Combined NMOS and PMOS R_{DSON} Including Bond Wire Resistance	$I_{OUT} = 800\text{mA}$	—	1.8	3.46	Ω
		$I_{OUT} = 500\text{mA}$	—	1.8	3.46	Ω
V_{REFQ}	REF Quiescent Voltage	$I_{REF} = 0$	185	200	215	mV
R_{REF_IN}	REF Pin Input Resistance	$0 < V_{REF} < 0.5\text{V}$	4.5	6	7.5	k Ω
V_{FBQ}	FB Quiescent Voltage	$I_{FB} = 0$	185	200	215	mV
R_{FB_IN}	REF Pin Input Resistance	$0 < V_{FB} < 0.5\text{V}$	4.5	6	7.5	k Ω
$I_{HYST_IO_250}$	Current Offset	$I_{REF} = I_{FB} = 250\mu\text{A}$, $V_{HYST} = V_{DD}/2$	-2	0.35	3	μA
$I_{HYST_IO_40}$		$I_{REF} = I_{FB} = 40\mu\text{A}$, $V_{HYST} = V_{DD}/2$	-1.3	0	1.3	μA
V_{HYST_H}/V_S	Threshold Voltage High	—	—	52	—	%
V_{DB_H}/V_S	Deadband Voltage High	—	—	50.4	—	%
V_{DBL}/V_S	Deadband Voltage Low	—	—	49.6	—	%
V_{HYST_L}/V_S	Threshold Voltage Low	—	—	48	—	%
V_{HYST_W}/V_S	Hysteresis Window	$(V_{HYH} - V_{HYL}) / V_{DD}$	3	4	5	%
V_{DB_W}/V_S	Deadband Window	$(V_{DBH} - V_{DBL}) / V_{DD}$	0.4	0.8	1.2	%
I_{RANGE}	Range Pin Input Current	$0\text{V} < V_{RANGE} < V_{DD}$	-1	—	1	μA
V_{OFFH}	Range Pin Input Voltage Monitor Switch-Off Voltage High	Referred to V_{DD}	-100	0	150	mV
V_{OFFL}	Range Pin Input Voltage Monitor Switch-Off Voltage Low	Referred to GND	300	400	500	mV
I_{OCP}	Overcurrent protection	—	1.5	—	—	A
$T_{J_SDN_TH}$	IC Junction Temperature Thermal Shutdown Threshold	—	150	+170	190	$^{\circ}\text{C}$
$T_{J_SDN_HYST}$	IC Junction Temperature Thermal Shutdown Hysteresis	—	—	+30	—	$^{\circ}\text{C}$

Note: 13. Typical data is measured at $T_A = +25^{\circ}\text{C}$, $V_{DD} = 12\text{V}$. The maximum and minimum parameters values over operating temperature range are not tested in production, and they are guaranteed by design, characterization, and process control.

Operating Characteristics

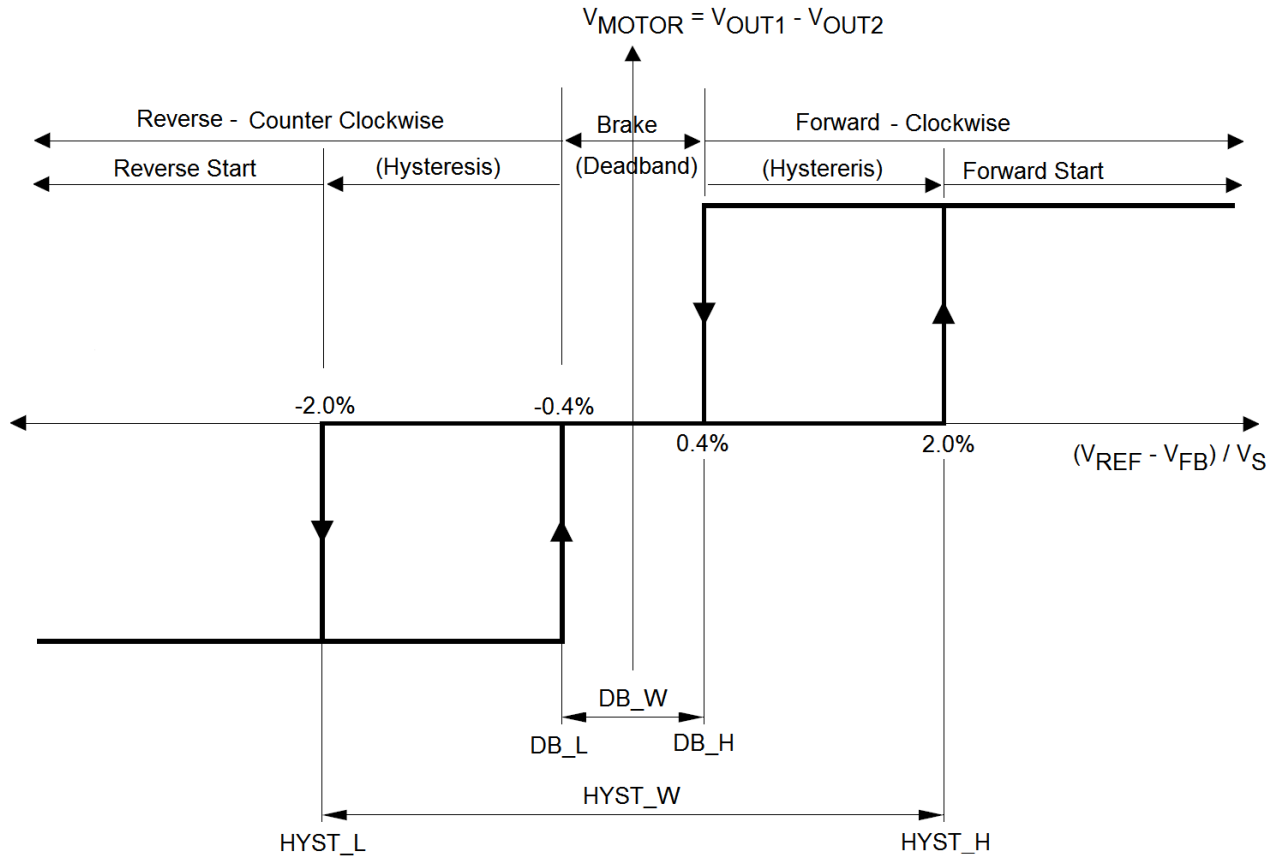
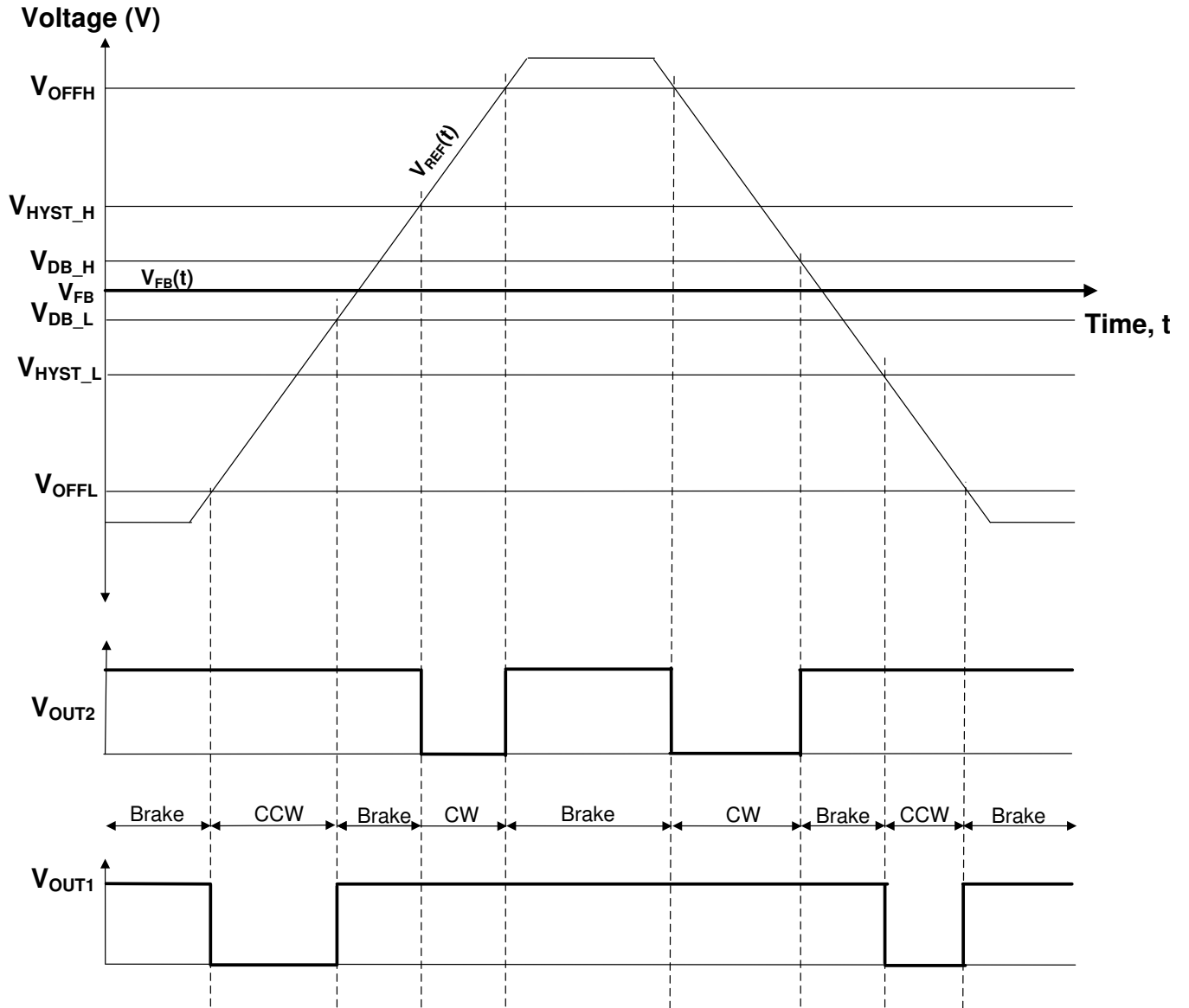

Figure 1. Hysteresis, Deadband, and Rotation Directions

Operating Characteristics (continued)



CW: Clockwise
CCW: Counter Clockwise

Figure 2. Rotation Directions with Respect to V_{REF} , V_{FB} , Hysteresis, and Deadband Settings

Application Note

REF and FB Pin

The REF and FB pins are servo AMP input, and the voltage difference between REF/FB terminals are based on the OUT1 and OUT2 operating status (like CW/CCW or Brake status on page 6 and 7). For normal operating, the voltage applied to REF/FB terminals does not exceed 1.5V ($= 6k \times 250\mu A$; refer to *Electrical Characteristics* section). The two pins both have a series resistor with same value to degrade applied voltage. 1.5V is the maximum voltage at REF/FB pin, so R_{REF}/R_{FB} resistor is calculated as below:

Assuming $V_{DD} = 12V$ and 1.5V maximum on FB/REF pin, the minimum R_{REF}/R_{FB} is equal to $1.5V = \{6K / (6K + R_{REF})\} \times 12V$; $R_{REF} = 42k\Omega$.

HYST Pin

The hysteresis window can be set via input at HYST pin. If the two resistances R_{HYH} and R_{HYL} are equal, the hysteresis window is located symmetrically at $50 \pm 2\%$ relative to the supply voltage. The position of the window can be adjusted by varying the ratio of R_{HYH} to R_{HYL} . The size of the window tolerance can be adjusted by changing the ratio of the hysteresis resistances to the resistances R_{REF} and R_{FB} on the other. For example, if the resistances R_{HYH} and R_{HYL} are both halved in comparison to R_{REF} and R_{FB} , the window tolerance doubles in size (i.e. to $50 \pm 4\%$).

RANGE Pin

If the potentiometer or the connecting leads reference input to V_{REF} are shorted or open connected, uncontrolled movements of the servo motor must not occur. For this reason, two additional switch-off thresholds V_{OFFL} and V_{OFFH} are provided. The corresponding window comparator for these thresholds behind the RANGE input has a typical low threshold of 0.4V and a typical high threshold of V_{DD} . If the voltage V_{REFIN} falls below 0.4V typical, which will be the case if the reference potentiometer input is shorted to ground, the motor will be switched off. Similarly, if the voltage V_{REFIN} rises above V_{DD} typical, which will be the case if the reference potentiometer input is open circuited, the motor will be switched off.

Undervoltage Lockout

To make sure the minimum voltage required to operate the driver is supplied, the ZXBM5408Q has an undervoltage lockout. At start up the device only starts if the supply voltage is typically over V_{UVLO_RLTH} . During normal operation, the device will switch off all the output switches and power down if the supply voltage drops below V_{UVLO_TH} typical.

When the supply voltage drops below undervoltage lockout threshold, $V_{UVLO_TH_R}$, the ZXBM5408Q shuts down all the output drive switches and enters standby mode to help prevent overvoltage stress on the coil.

Overvoltage Shutdown of Output Drive

When the supply voltage exceeds the overvoltage shutdown threshold, V_{OV_TH} , the ZXBM5408Q shuts down all the output drive switches and enters standby mode to help prevent overvoltage stress on the coil. The driver returns to normal condition if the supply voltage drops below V_{OV_RLTH} provided no other fault condition or signals are preventing it to enter normal operation.

Overcurrent Protection

The internal overcurrent protection (OCP) threshold is 1.5A minimum at 12V supply +25°C.

When the motor current exceeds the OCP threshold for longer than $4\mu s$ typical on any of the H-Bridge switches, the device switches off all the output switches and remains off for $260\mu s$ typical. The IC returns to normal operation after the $260\mu s$ if overcurrent condition has gone away. If the motor current is still higher than the OCP threshold, the device enters another $260\mu s$ standby mode.

Thermal Shutdown Protection

The device has an internal thermal shutdown to prevent a thermal runaway scenario. The thermal shutdown is triggered when the junction temperature of the device reaches +170°C. It will remain in standby mode until the junction temperature falls by +30°C.

Typical Operating Characteristics

Supply Current

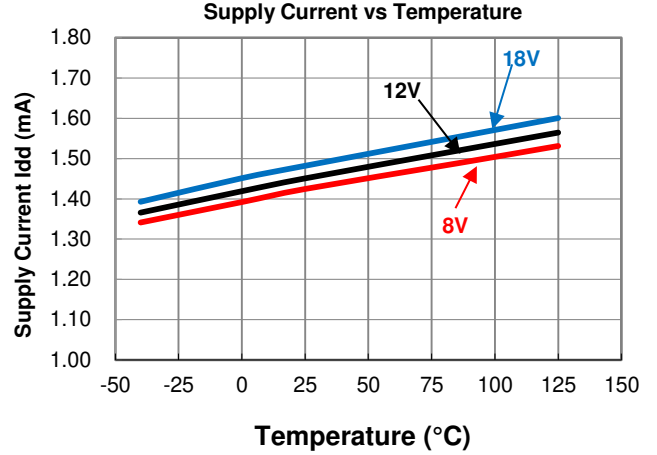
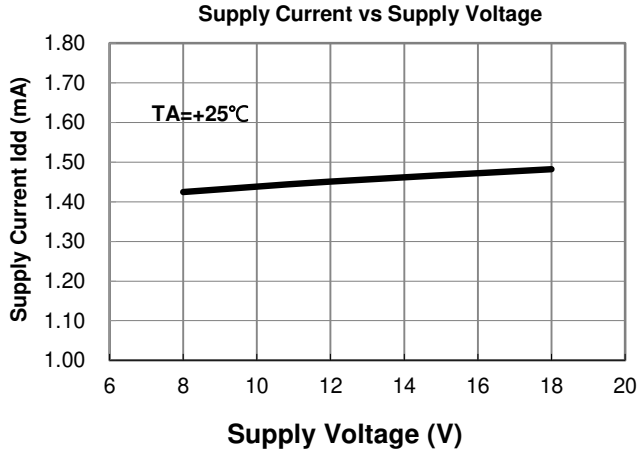

UVLO and OVP Threshold

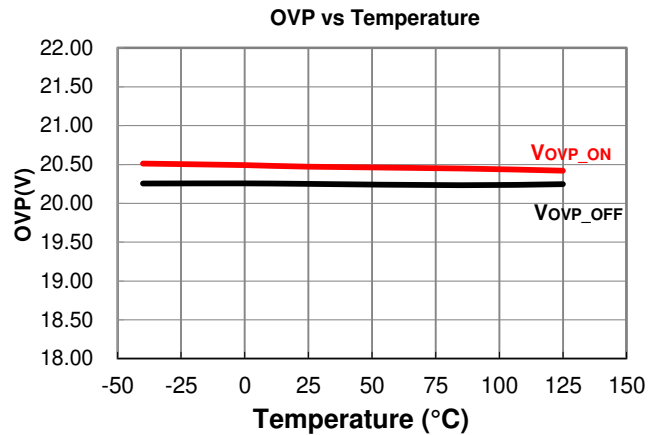
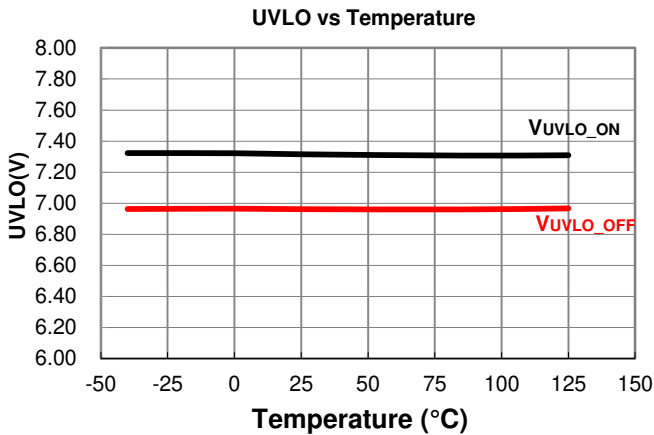

Typical Operating Characteristics (continued)

Total H-Bridge Path Resistance – Total RDS(ON) of High-Side and Low-Side Switches

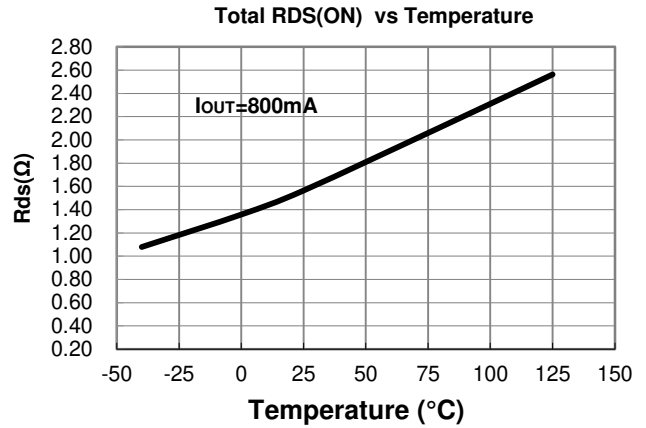
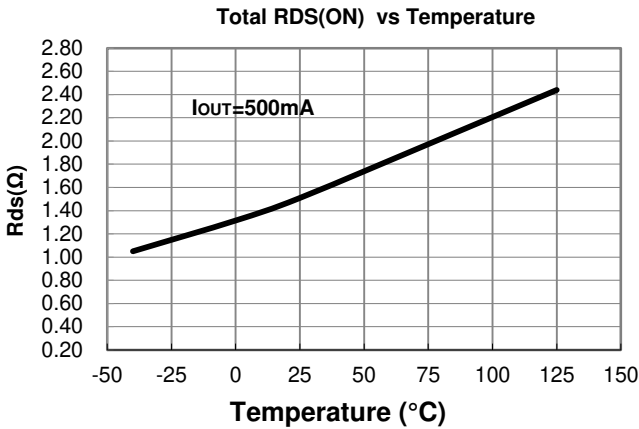
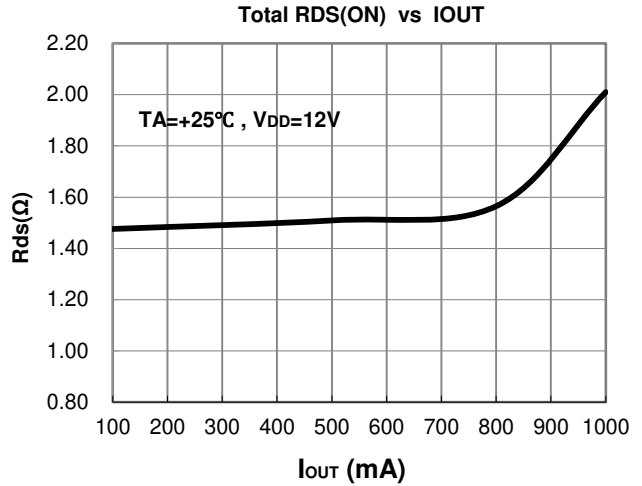
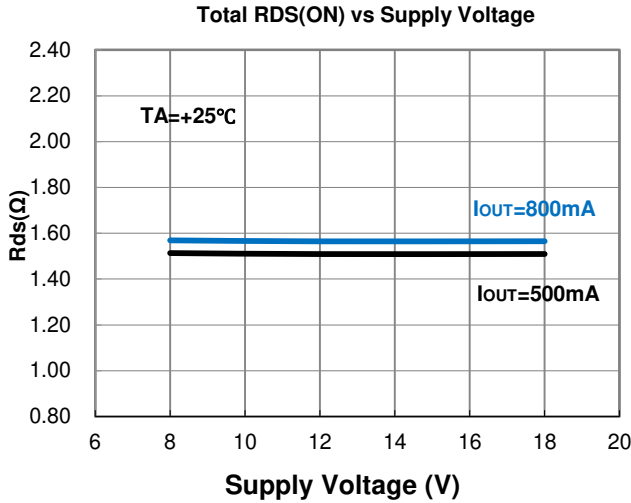

Typical Operating Characteristics (continued)

VOFFH : Range pin input voltage referred to VDD

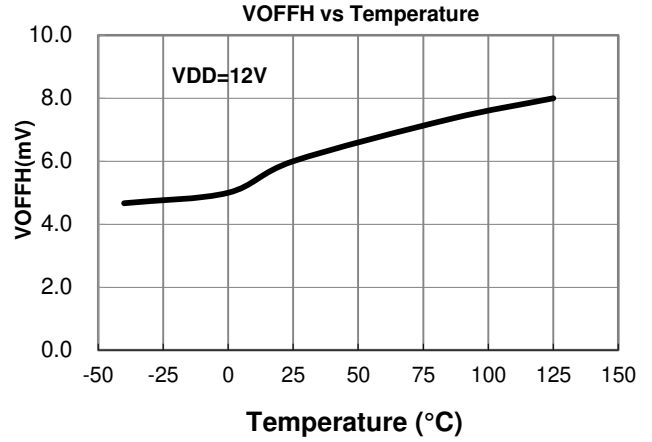
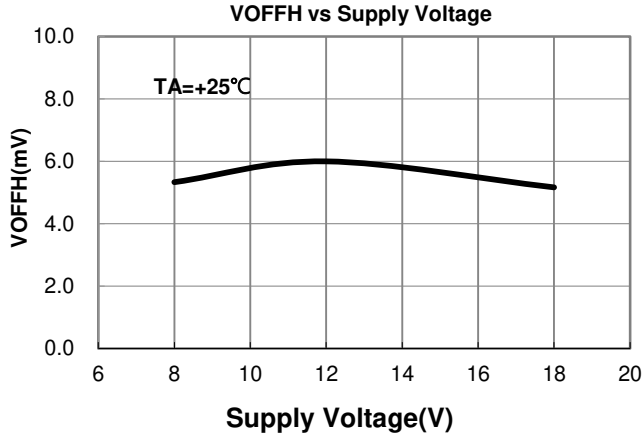

VOFFL : Range Pin input voltage referred to GND

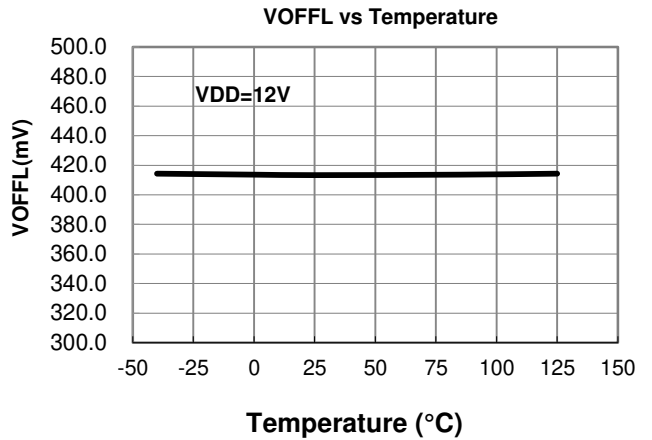
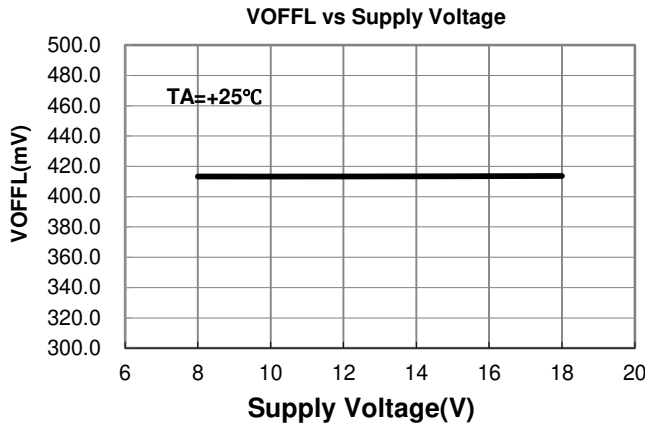

Thermal Performance

(1) Package Type: PDIP-8 (Type A1)

PDIP-8 (Type A1) Power Dissipation De-rating Curve 1 (Note 14)

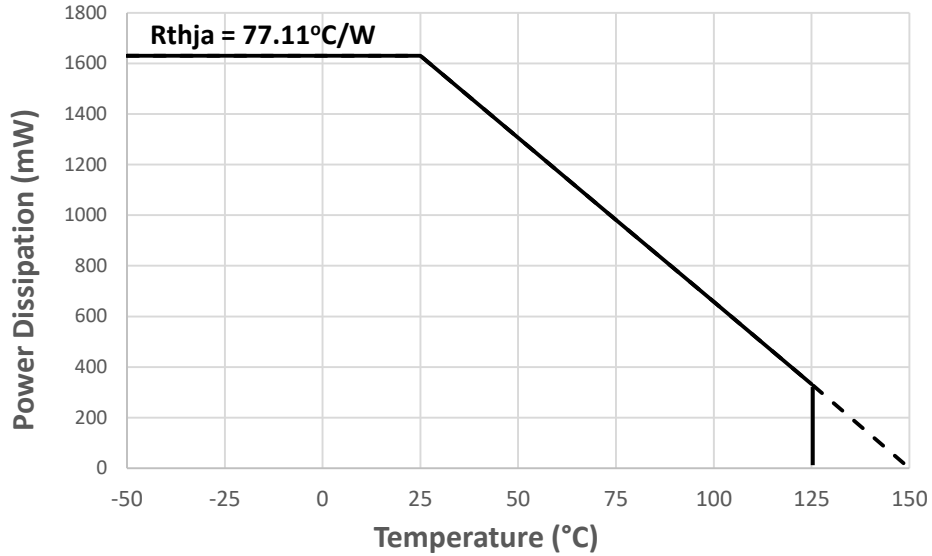

Note: 14. PDIP-8 (Type A1) soldered to minimum recommended landing pads on 2" x 2" two-layer 2oz.copper FR-4 PCB (1.6mm thickness).

(2) Package Type: SO-14 (Type A1)

SO-14 Power Dissipation De-rating Curve 1 (Note 15)

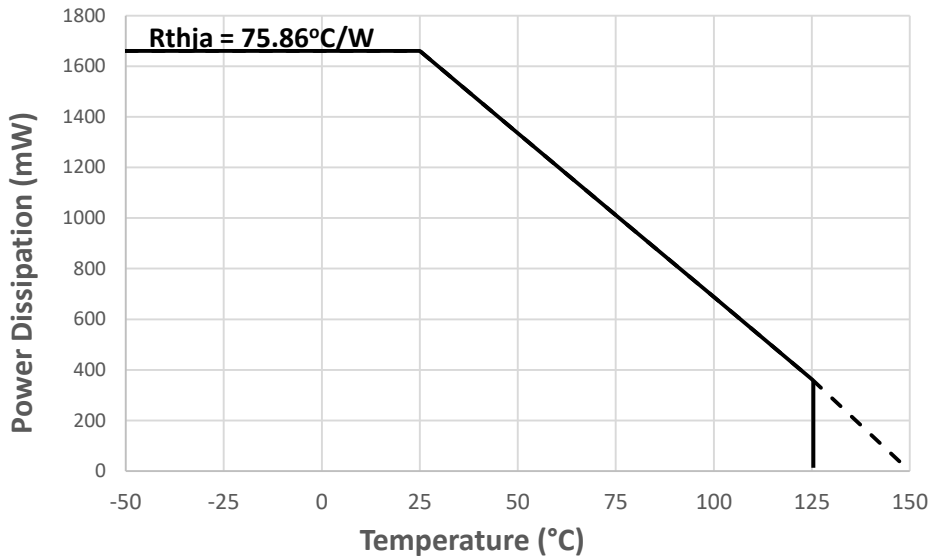

Note: 15. The SO-14 pad is soldered to the minimum recommended landing pads (see Package Outline Dimension section) on a 2" x 2" 2oz. copper FR4 PCB (1.6mm thickness) with no copper flood connecting to the landing pattern or on the bottom layer.

Ordering Information (Note 16)

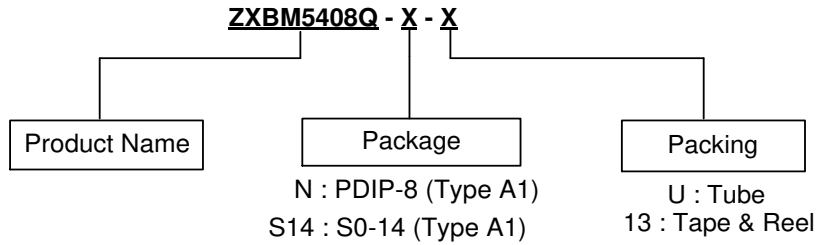

Part Number	Package Code	Packaging (Note 17)	Tube(Note 19)		13" Tape and Reel		Compliance (Note 18)
			Quantity	Part Number Suffix	Quantity	Part Number Suffix	
ZXBM5408Q -N-U	N	PDIP-8 (Type A1)	60	-U	NA	NA	Automotive Grade Compliant
ZXBM5408Q -S14-13	S14	SO-14 (Type A1)	NA	NA	2,500/Tape & Reel	-13	Automotive Grade Compliant

- Notes: 16. For packaging details, go to our website at <https://www.diodes.com/design/support/packaging/diodes-packaging/>.
 17. Pad layout as shown on Diodes Incorporated's Suggested pad layout can be found at <https://www.diodes.com/design/support/packaging/>.
 18. ZXBM5408Q -N-U is classified as "Automotive Compliant" and supports PPAP documentation.
 19. There are 60 tubes in a box and the standard order quantity is 3600 pcs.

Marking Information

1. Package Type: PDIP-8 (Type A1)

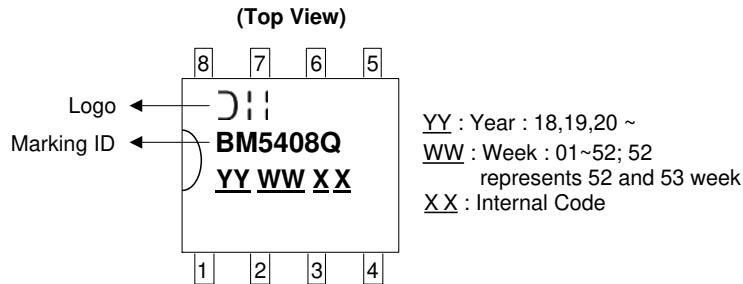

2. Package Type: SO-14 (Type A1)

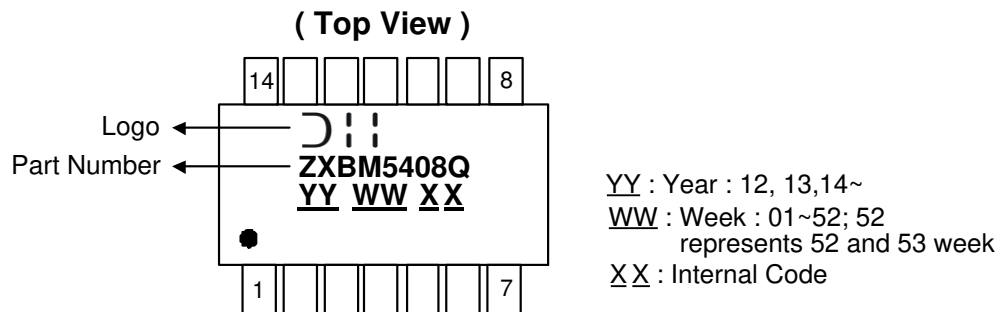

Package Outline Dimensions (All dimensions in mm.)

Please see <https://www.diodes.com/design/support/packaging/> for the latest version.

1. Package Type: PDIP-8 (Type A1)

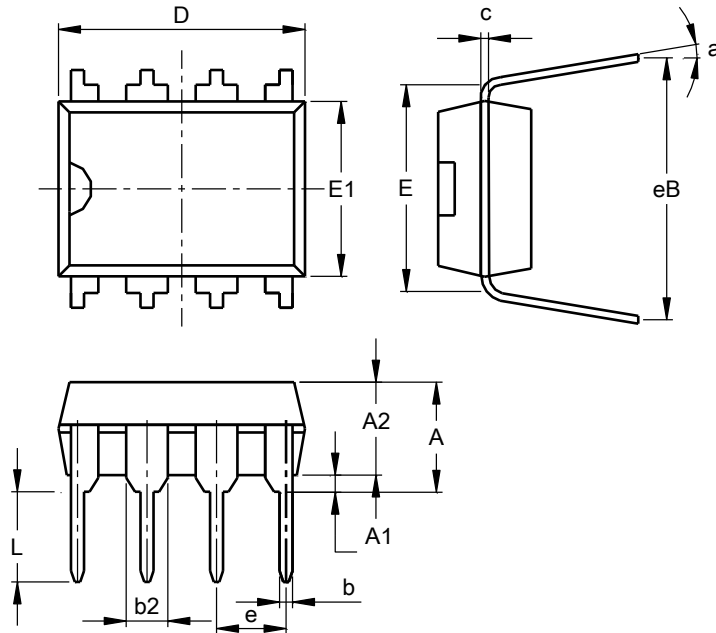

PDIP-8 (Type A1)						
Dim	Inches			Millimeters		
	Min	Max	Typ	Min	Max	Typ
A	--	0.210	--	--	5.334	--
A1	0.015	--	--	0.381	--	--
A2	0.125	0.135	0.130	3.175	3.429	3.302
b	--	--	0.018	--	--	0.457
b2	--	--	0.060	--	--	1.524
c	0.008	0.014	0.010	0.203	0.356	0.254
D	0.355	0.400	0.365	9.017	10.160	9.271
E	0.300 BSC			7.62 BSC		
E1	0.245	0.255	0.250	6.223	6.477	6.350
eB	0.335	0.375	0.355	8.509	9.525	9.017
e	--	--	0.100	--	--	2.540
L	0.115	0.150	0.130	2.921	3.810	3.302
a	0°	15°	7°	0°	15°	7°

Controlling dimensions are in inches

2. Package Type: SO-14 (Type A1)

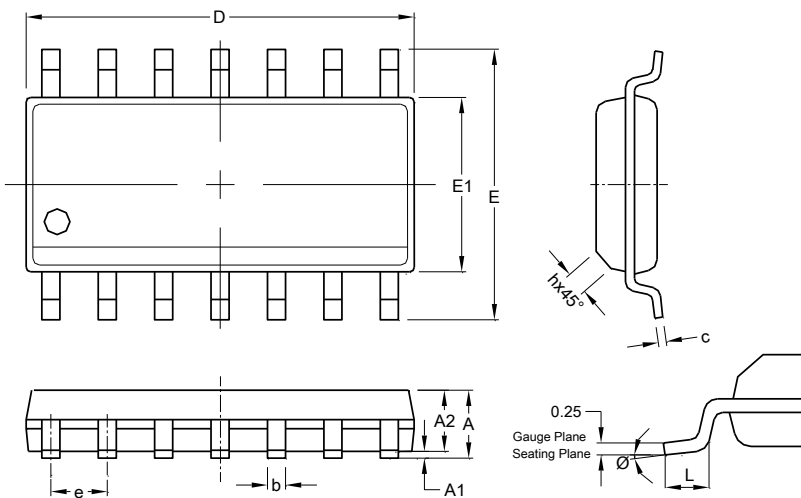

SO-14 (Type A1)			
Dim	Min	Max	Typ
A	--	1.75	--
A1	0.10	0.25	--
A2	1.25	--	--
b	0.31	0.51	--
c	0.10	0.25	--
D	8.65 BSC		
E	6.00 BSC		
E1	3.90 BSC		
e	1.27 BSC		
h	0.25	0.50	--
L	0.40	1.27	--
θ	0°	8°	--

All Dimensions in mm

Suggested Pad Layout

Please see <https://www.diodes.com/design/support/packaging/> for the latest version.

SO-14 (Type A1)

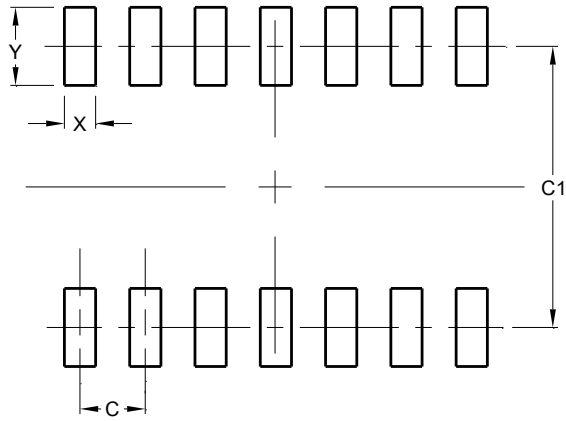

Dimensions	Value (in mm)
C	1.27
C1	5.40
X	0.60
Y	1.50

IMPORTANT NOTICE

1. DIODES INCORPORATED (Diodes) AND ITS SUBSIDIARIES MAKE NO WARRANTY OF ANY KIND, EXPRESS OR IMPLIED, WITH REGARDS TO ANY INFORMATION CONTAINED IN THIS DOCUMENT, INCLUDING, BUT NOT LIMITED TO, THE IMPLIED WARRANTIES OF MERCHANTABILITY, FITNESS FOR A PARTICULAR PURPOSE OR NON-INFRINGEMENT OF THIRD PARTY INTELLECTUAL PROPERTY RIGHTS (AND THEIR EQUIVALENTS UNDER THE LAWS OF ANY JURISDICTION).
2. The Information contained herein is for informational purpose only and is provided only to illustrate the operation of Diodes' products described herein and application examples. Diodes does not assume any liability arising out of the application or use of this document or any product described herein. This document is intended for skilled and technically trained engineering customers and users who design with Diodes' products. Diodes' products may be used to facilitate safety-related applications; however, in all instances customers and users are responsible for (a) selecting the appropriate Diodes products for their applications, (b) evaluating the suitability of Diodes' products for their intended applications, (c) ensuring their applications, which incorporate Diodes' products, comply the applicable legal and regulatory requirements as well as safety and functional-safety related standards, and (d) ensuring they design with appropriate safeguards (including testing, validation, quality control techniques, redundancy, malfunction prevention, and appropriate treatment for aging degradation) to minimize the risks associated with their applications.
3. Diodes assumes no liability for any application-related information, support, assistance or feedback that may be provided by Diodes from time to time. Any customer or user of this document or products described herein will assume all risks and liabilities associated with such use, and will hold Diodes and all companies whose products are represented herein or on Diodes' websites, harmless against all damages and liabilities.
4. Products described herein may be covered by one or more United States, international or foreign patents and pending patent applications. Product names and markings noted herein may also be covered by one or more United States, international or foreign trademarks and trademark applications. Diodes does not convey any license under any of its intellectual property rights or the rights of any third parties (including third parties whose products and services may be described in this document or on Diodes' website) under this document.
5. Diodes' products are provided subject to Diodes' Standard Terms and Conditions of Sale (<https://www.diodes.com/about/company/terms-and-conditions/terms-and-conditions-of-sales/>) or other applicable terms. This document does not alter or expand the applicable warranties provided by Diodes. Diodes does not warrant or accept any liability whatsoever in respect of any products purchased through unauthorized sales channel.
6. Diodes' products and technology may not be used for or incorporated into any products or systems whose manufacture, use or sale is prohibited under any applicable laws and regulations. Should customers or users use Diodes' products in contravention of any applicable laws or regulations, or for any unintended or unauthorized application, customers and users will (a) be solely responsible for any damages, losses or penalties arising in connection therewith or as a result thereof, and (b) indemnify and hold Diodes and its representatives and agents harmless against any and all claims, damages, expenses, and attorney fees arising out of, directly or indirectly, any claim relating to any noncompliance with the applicable laws and regulations, as well as any unintended or unauthorized application.
7. While efforts have been made to ensure the information contained in this document is accurate, complete and current, it may contain technical inaccuracies, omissions and typographical errors. Diodes does not warrant that information contained in this document is error-free and Diodes is under no obligation to update or otherwise correct this information. Notwithstanding the foregoing, Diodes reserves the right to make modifications, enhancements, improvements, corrections or other changes without further notice to this document and any product described herein. This document is written in English but may be translated into multiple languages for reference. Only the English version of this document is the final and determinative format released by Diodes.
8. Any unauthorized copying, modification, distribution, transmission, display or other use of this document (or any portion hereof) is prohibited. Diodes assumes no responsibility for any losses incurred by the customers or users or any third parties arising from any such unauthorized use.
9. This Notice may be periodically updated with the most recent version available at <https://www.diodes.com/about/company/terms-and-conditions/important-notice>

DIODES is a trademark of Diodes Incorporated in the United States and other countries.
The Diodes logo is a registered trademark of Diodes Incorporated in the United States and other countries.
© 2022 Diodes Incorporated. All Rights Reserved.

www.diodes.com