

REVISIONS					
P	LTR	DESCRIPTION	DATE	DRN	APVD
G2		REV. ECO 17-011267	04SEP2017	HC	KR

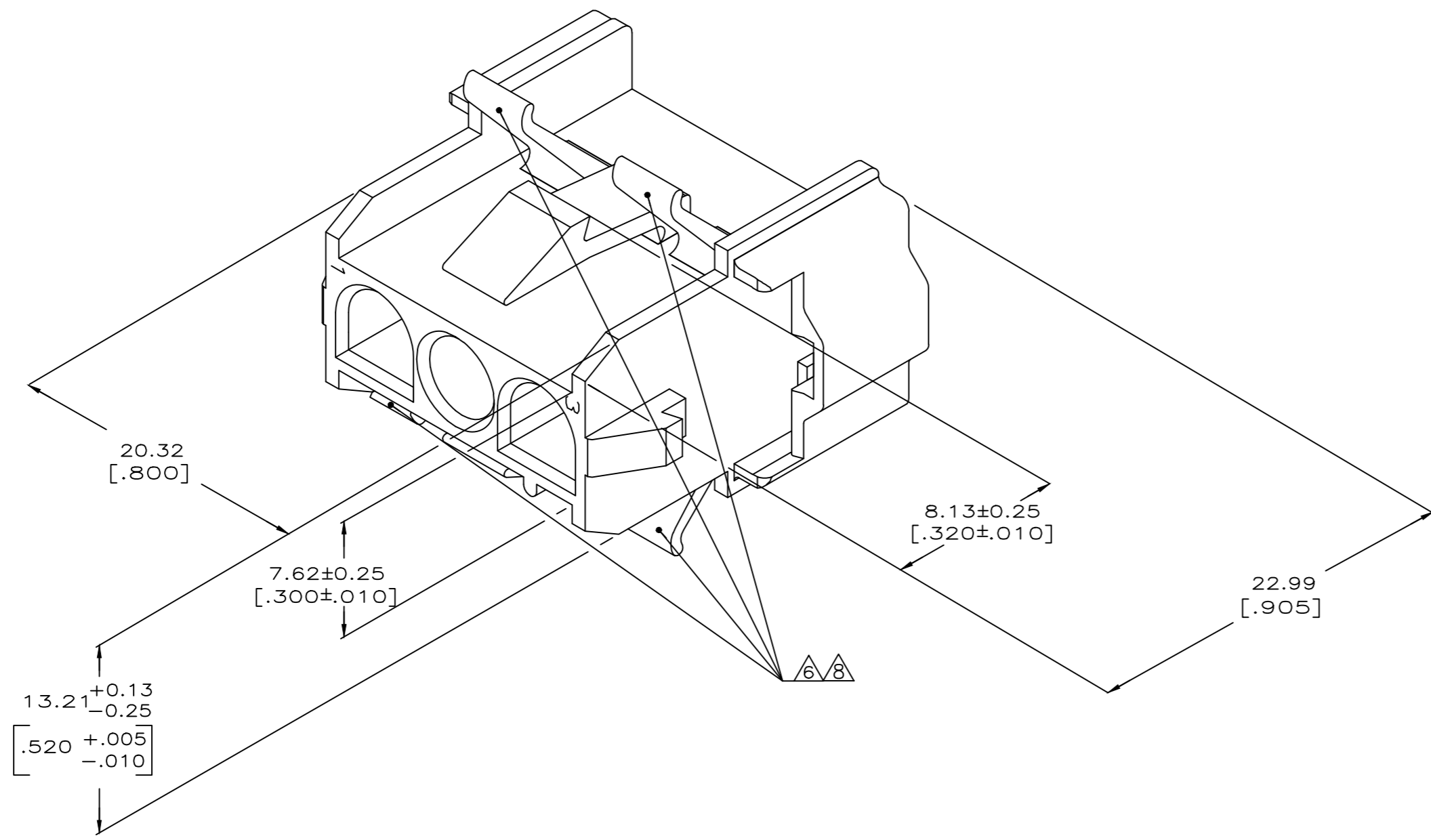

1. MUST BE ASSEMBLED WITH CAP REAR P/N 770048-1 BEFORE MATING. KIT P/N IS 770025-1.
2. RECOMMENDED PANEL THICKNESS 0.76-2.29 [.030-.090].
3. PANEL MUST BE PUNCHED SO THAT THE HOUSING ENTERS THE PANEL IN THE SAME DIRECTION AS THE PUNCH.
4. OPTIONAL FOR KEYING HOUSING IN PANEL.
5. CIRCUIT NUMBER 1 LOCATION.
6. AMP LOGO LOCATED ONCE ON ANY INDICATED SURFACE FARSIDE.
7. DIMENSIONS SHOWN REPRESENT PRODUCT IN DRY, AS MOLDED, CONDITION. ADDITIONAL 2% GROWTH DUE TO SUBSEQUENT MOISTURE ABSORPTION MAY OCCUR AND SHOULD BE ACCOUNTED FOR.
8. CSA LOGO LOCATED ONCE ON ANY INDICATED SURFACE.

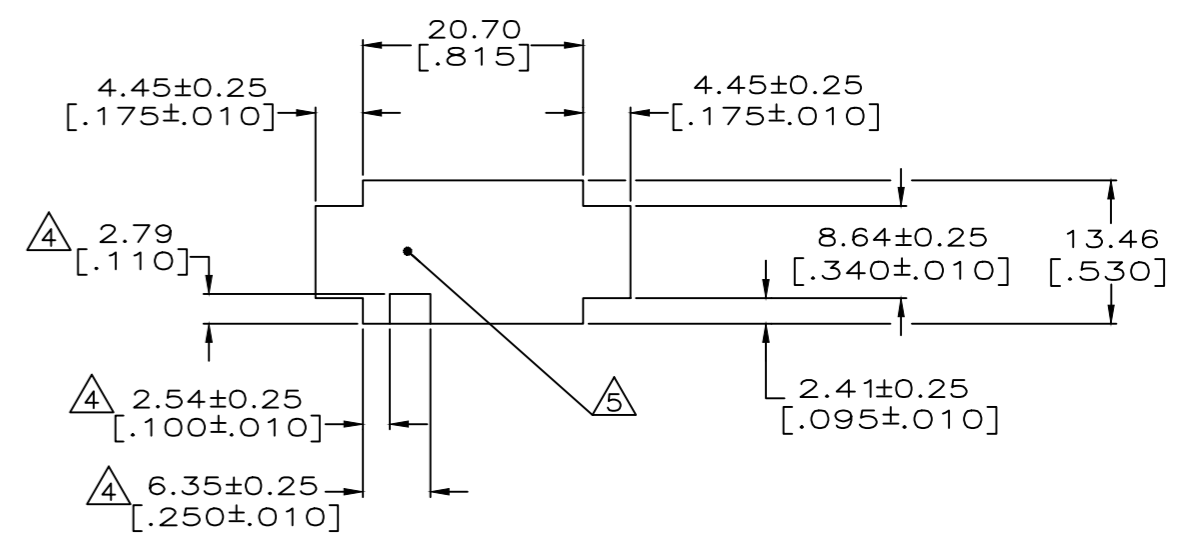

RECOMMENDED PANEL CUTOUT
 (HOUSING ENTRY SIDE)
 SCALE 2:1



770047-1
 PART NUMBER

THIS DRAWING IS A CONTROLLED DOCUMENT.		DRN K. SALMON 1-15-92	TE Connectivity	
DIMENSIONS: INCHES		CHK R. SWING 1-15-92	NAME	
TOLERANCES UNLESS OTHERWISE SPECIFIED:		APVD	PRODUCT SPEC	
0 PLC ± -	1 PLC ± -	NAME	CAP FRONT, 3 CIRCUIT, UNIVERSAL MATE-N-LOK	
2 PLC ± -	3 PLC ± 0.13 [.005]	APPLICATION SPEC	-	
4 PLC ± -	ANGLES ± -	SIZE	CAGE CODE	DRAWING NO
MATERIAL NYLONUL94V-0	FINISH	WEIGHT 0.000000	A1 00779	770047
CUSTOMER DRAWING		SCALE	5:1	SHEET 1 of 1
		REV	G2	