

Dual 500mA/500mA Low Dropout, Low Noise, Micropower Linear Regulator

DESCRIPTION

Demonstration circuit 1408 is a dual 500mA/500mA linear regulator featuring LT[®]3029. LT3029 is a dual, micro-power, low noise and low dropout voltage linear regulator. The device operates either with a common input supply or independent input supplies for each channel, over an input range of 1.8V to 20V. Each output supplies up to 500mA of output current with a typical dropout voltage of 300mV. A 10nF bypass capacitor reduces output noise to 20 μ V_{RMS} in a 10Hz to 100kHz bandwidth. The low 55 μ A quiescent current per channel makes it an ideal choice for battery-powered systems. Shutdown control is independent for each channel, allowing for flexible power management.

LT3029 optimizes the stability and transient response with low ESR ceramic cap, requiring a minimum of 3.3 μ F. Internal circuitry provides reverse-battery protection, reverse-current protection, current limiting with foldback and thermal shut-

down. The current limiting should be considered for the input voltage range under full load condition.

The device is available in the thermally-enhanced 16-Lead 4mm \times 3mm \times 0.75mm DFN and 16-lead MSOP packages.

The LT3029 datasheet gives a complete description of the part, operation and application information. The datasheet must be read in conjunction with this quick start guide for demo circuit 1408.

Design files for this circuit board are available. Call the LTC factory.

LT, LTC and LT are registered trademarks of Linear Technology Corporation. All other trademarks are the property of their respective owners.

Table 1. Performance Summary (T_A = 25°C)

PARAMETER	CONDITION	VALUE
Minimum Input Voltage		2.3V
Maximum Input Voltage		20V
Output Voltage V _{OUT}	Shunt at 3,4 for JP3 and JP4	1.794V \pm 2.6%
Maximum Output Current Per Channel	V _{IN} =2.5V, V _{OUT} =1.8V	500mA

QUICK START PROCEDURE

Demonstration circuit 1408 is easy to set up to evaluate the performance of the LT3029. Refer to Figure 1 for proper measurement equipment setup and follow the procedure below:

NOTE: Make sure that the input voltage does not exceed 20V.

NOTE: The shutdown jumper JP1 and JP2 shunt is required to be placed in the OFF or ON position for proper operation.

NOTE: Place the output voltage selection jumper JP3 and JP4 at the desired position.

1. Connect the power supply (with power off), load, and meters as shown in Figure 1.
2. After all connections are made, turn on input power and verify that the output voltage accord-

ing to the output voltage selection jumper (JP3 and JP4).

NOTE: If the output voltage is too low, temporarily disconnect the load to make sure that the load is not set too high.

3. Once the proper output voltages are established, adjust the load within the operating range and observe the output voltage regulation, efficiency and other parameters.

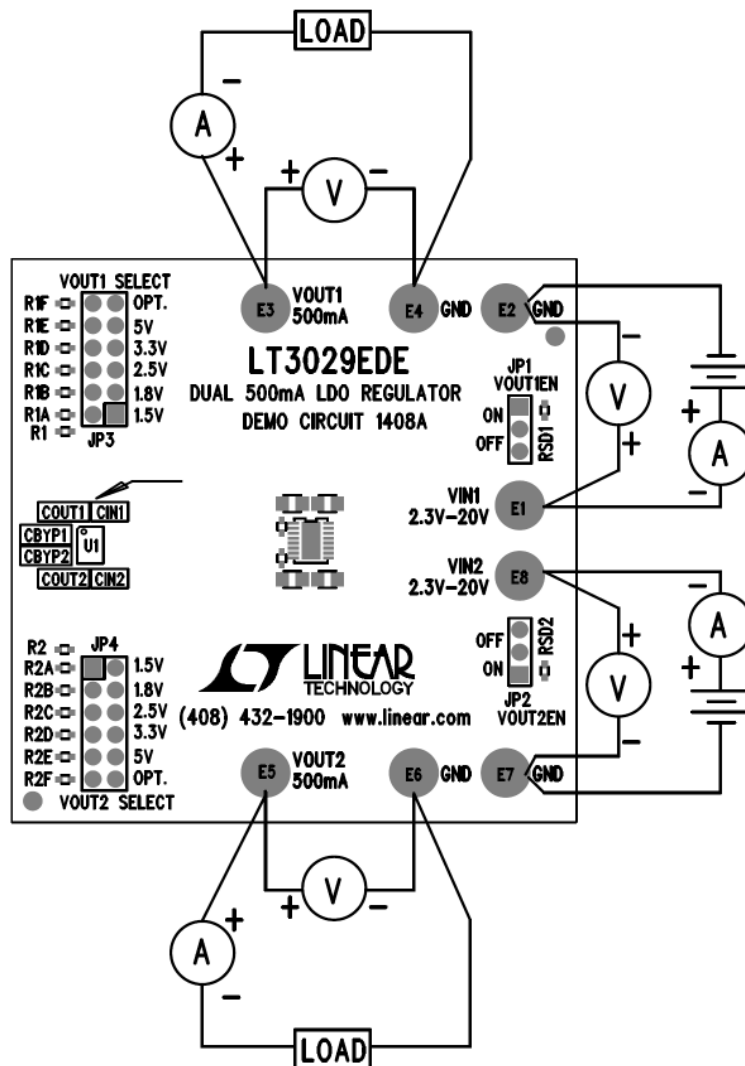

Figure 1. Proper Measurement Equipment Setup

