

1. Packing Material 包材 - Tray 1 PC

Quantity 數量 - 1*110=110 PCS

Tray: Body and Cover 真空盒上下蓋各 - 1PC Each
Label 标签 - 1 PC

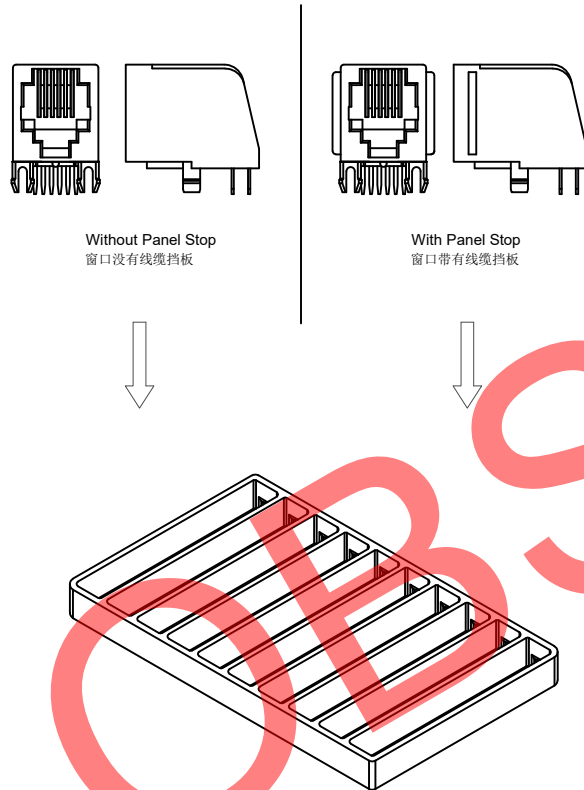

2. Packing Material 包材 - Carton - 380*320*490 - 1 PC

Quantity 數量 - 110*40=4400 PCS

Part Number 零部件料号	Panel Stop 线缆挡板	Net Weight 淨重	Gross Weight 毛重	Q'TY 數量
MJ3215-64-1-X-X	With	14.96Kg	18.51Kg	4400
MJ3215-66-1-X-X	With	17.36Kg	21.34Kg	4400

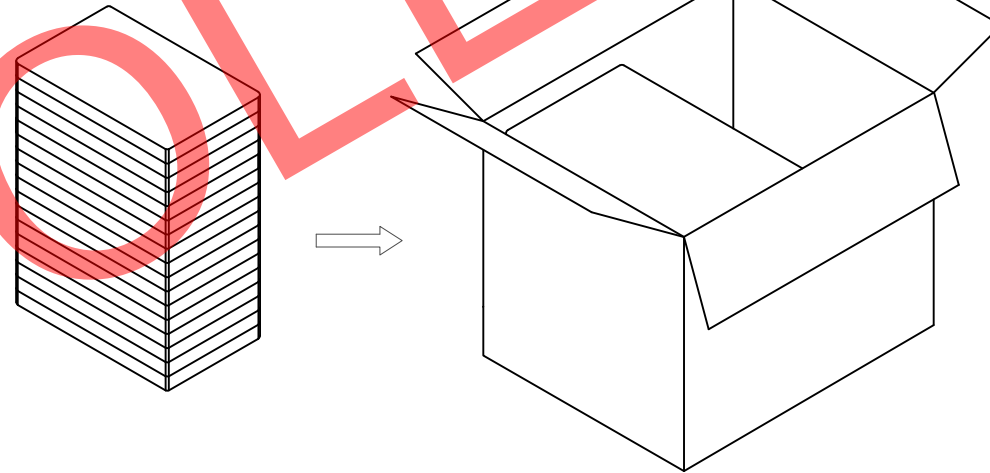

Part Number MJ3215-6		Product Description Modular Jack Connector, 6 Position, Category 3, Right Angle Through Hole, Standard Profile, Standard Latch		
Drawing Date 10th May 2010				
By CC	Tolerances (Except as Noted) Length	Units: Metric (mm)		This drawing is confidential and copyright of Global Connector Technology, Ltd (GCT). This drawing must not be copied or disclosed without written consent. E & OE
Detail Obsolete	Angle			
Revision X				Not to Scale Drawn By PKN Sheet No. 2/2
Date 15/08/22				

