

8 7 6 5 4 3 2 1

- NOTES:
1. MOUNTING: Mounts in a $\phi .312 \pm .002$ [$\phi 7.92\text{mm} \pm .05$] panel hole on .500 [12.7mm] centers. Panel thickness .031 [.8mm] to .125 [3.18mm]. Panel hole should be deburred, but not chamfered.
 2. ASSEMBLY: Insert lens through panel hole, slide lock washer onto lens barrel and twist on retaining ring. PCB mounted LEDs slide into lens when the panel cover is closed or the PCB card is inserted into the case.
 3. MATERIAL: Lens-Polycarbonate, UL 94-V2
Lock Washer- FH Steel, Nickel plate
Retaining ring - Thermoplastic, U.L. 94 V0 Rated
Seal- EPDM
 4. U.S. & Foreign Pat. Issued & Pend.

REVISIONS				
ECN#	REV.	DESCRIPTION	DATE	INITIALS
	001	REVISED PER EC R111009AZ01	4-23-10	SMU

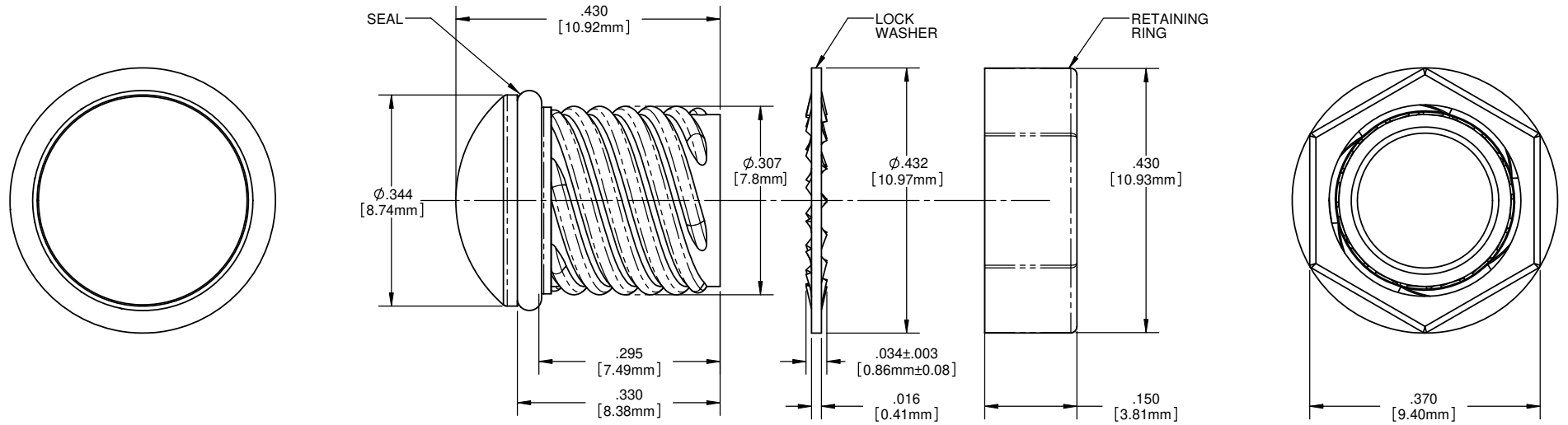
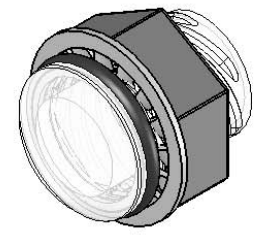

ORDERING CODE : CMS444 XXX

MODEL

LENS COLOR	
RTP	RED TRANSPARENT
ATP	AMBER TRANSPARENT
GTP	GREEN TRANSPARENT
BTP	BLUE TRANSPARENT
YTP	YELLOW TRANSPARENT
CTP	CLEAR TRANSPARENT

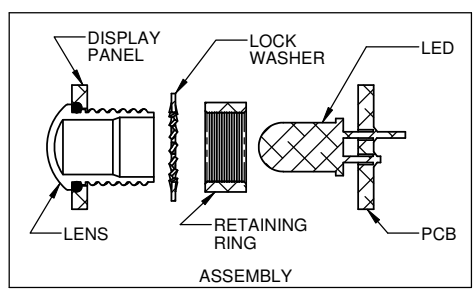

<small>UNLESS OTHERWISE SPECIFIED DIMENSIONS ARE IN INCHES</small> ANGLES DECIMALS ±1' X ±.020 FINISH XXX ±.010 XXX ±.005 <small>BREAK ALL CORNERS AND SHARP EDGES 90° MIN</small>	MATERIAL	SEE NOTES	VISUAL COMMUNICATIONS COMPANY, INC. <small>190 Bossick Boulevard, Suite 101 San Marcos, CA 92069 USA Phone (760) 560-1300 Fax (760) 560-1301 email vccsales@vccsite.com</small>	
	FINISH	SEE NOTES	TITLE: 5MM ROUND STANDARD THREADED PLAIN LENS WITH SEAL	
<small>THIRD ANGLE PROJECTION</small> <small>PROPRIETARY AND CONFIDENTIAL</small> <small>THE INFORMATION CONTAINED IN THIS DRAWING IS THE SOLE PROPERTY OF VISUAL COMMUNICATIONS COMPANY, INC. AND IS LOANED TO YOU AS A SINGLE COPY FOR YOUR CONVENIENCE ONLY. IT IS NOT TO BE REPRODUCED OR TRANSMITTED IN ANY FORM OR BY ANY MEANS, ELECTRONIC OR MECHANICAL, INCLUDING PHOTOCOPYING, RECORDING, OR BY ANY INFORMATION STORAGE AND RETRIEVAL SYSTEM.</small>	APPROVAL	DATE	SIZE	DWG. NO.
	DRAWN: SMU	4-23-10	B	CMS 444 XXX
	CHECKED: DZ	4-23-10	SCALE: 4:1	REV 001
	DO NOT SCALE DRAWING		SHEET 1 OF 1	

8 7 6 5 4 3 2 1