

REV.	DATE	ECR NO.	DESCRIPTION
NC	09/07/08	XXXXXX	INITIAL RELEASE
A	12/07/08	XXXXXX	ADD CRIMP NOTES
B	10/25/12	2398	ADD RECOMMENDED MOUNTING HOLE, UPDATED DRAWING FORMAT

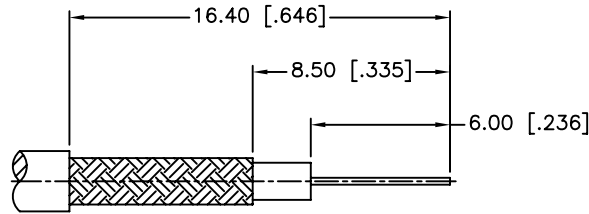

RECOMMENDED
CABLE STRIPPING DIM'S

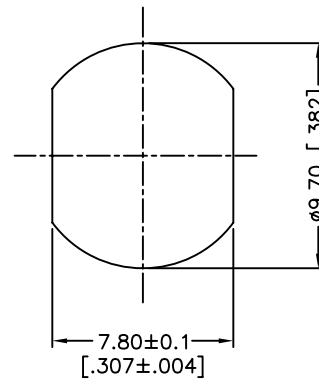
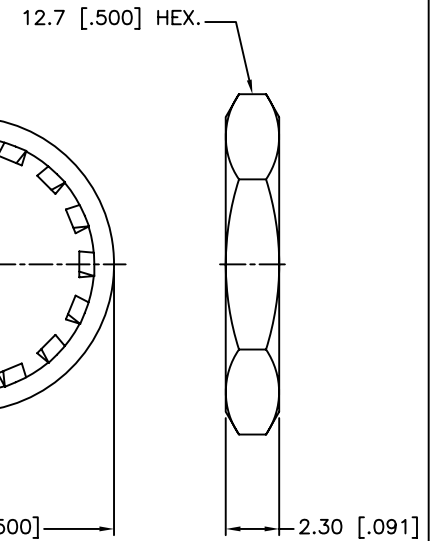
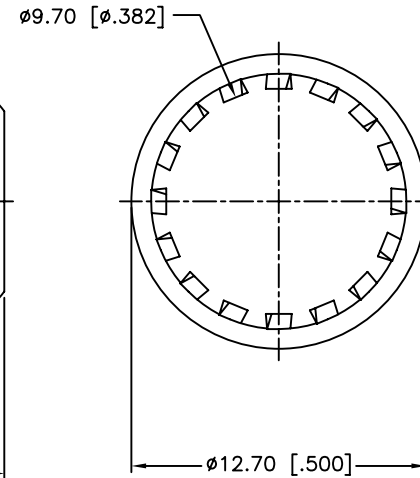
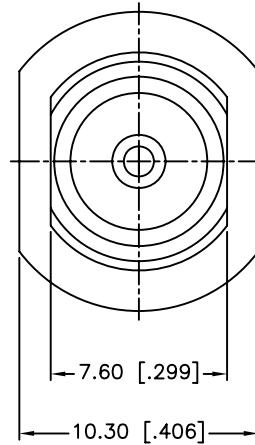
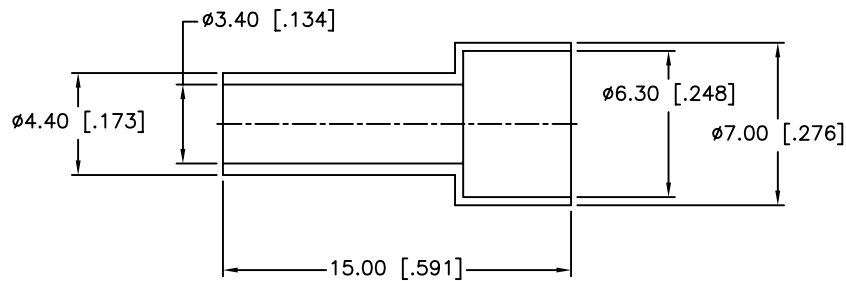
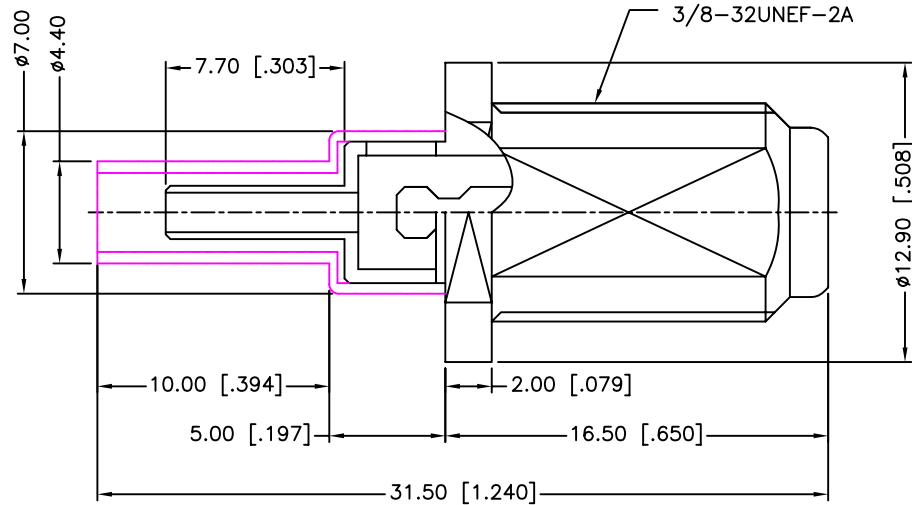

RECOMMENDED
MOUNTING HOLE

1. IMPEDANCE: 75 OHM
2. FREQUENCY RANGE: DC 0-3 GHz
3. DIELECTRIC WITHSTANDING VOLTAGE: 1500 VRMS, MIN.
4. DURABILITY: 100 CYCLES MIN.
5. TEMPERATURE RANGE: -40°C TO +140°C
6. CRIMPED FERRULE
HEX CRIMP SIZE .151"
7. CONTACT PIN TO SOLDER
8. MAX. PANEL THICKNESS=4.5mm

QTY	DESCRIPTION	MATERIAL	FINISH
1	FERRULE	BRASS	BRIGHT TIN
1	HEX NUT	BRASS	BRIGHT TIN
1	LOCK WASHER	BRASS	BRIGHT TIN
1	INSULATOR	P.P	NATURAL
1	CONTACT PIN	BRASS	BRIGHT TIN
1	INSULATOR	P.P	NATURAL
1	BODY	BRASS	BRIGHT TIN

UNLESS OTHERWISE SPECIFIED DIMENSIONS ARE IN MILLIMETERS. DIMENSIONS IN [] ARE IN INCHES AND FOR CUSTOMER REFERENCE ONLY.

UNLESS OTHERWISE SPECIFIED TOLERANCES FOR MILLIMETERS ARE:
0.5 - 8mm ± 0.20mm
8 - 30mm ± 0.40mm
30 - 120mm ± 0.50mm

UNLESS OTHERWISE SPECIFIED TOLERANCES FOR INCHES ARE:
.020 - .315 ± 0.007"
.315 - 1.180 ± 0.015"
1.180 - 4.724 ± 0.020"

DO NOT SCALE DRAWING

APPROVALS	DATE
DRAWN M.ZHANG	10/25/12
CHECKED	
ISSUED	
SHEET 1 OF 1	
CAD FILE C:/CONNEX/222167-10.DWG	

Amphenol Connex

PART DESCRIPTION
**F BULKHEAD CRIMP JACK
(FOR RG-179U/D WITH NUT AND WASHER)**

PART NO.
222167-10

DWG. NO. 222167-10.DWG	REV. B	SIZE A	SCALE NA
------------------------	--------	--------	----------