

IGBT with on-chip Gate-Emitter and Gate-Collector clamps

Features

- Most Rugged in Industry
- Logic-Level Gate Drive
- > 6KV ESD Gate Protection
- Low Saturation Voltage
- High Self-clamped Inductive Switching Energy
- Lead-Free

Description

The advanced IGBT process family includes a MOS gated, N-channel logic level device which is intended for coil-on-plug automotive ignition applications and small-engine ignition circuits. Unique features include on-chip active voltage clamps between the Gate-Emitter and Gate-Collector which provide over voltage protection capability in ignition circuits.

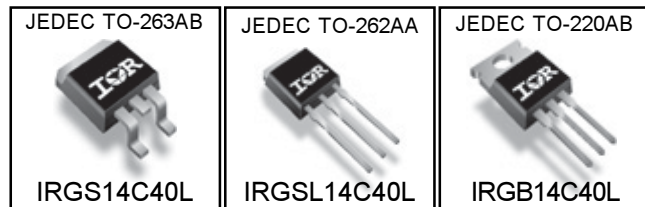
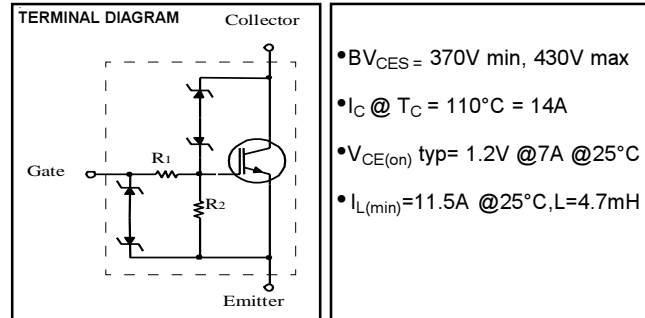

NOTE: IRGS14C40L is available in tape and reel. Add a suffix of TRR or TRL to the part number to determine the orientation of the device in the pocket, i.e, IRGS14C40LTRR or IRGS14C40LTRL.

Absolute Maximum Ratings

	Parameter	Max	Unit	Condition
V_{CES}	Collector-to-Emitter Voltage	Clamped	V	$R_G = 1K \text{ ohm}$
$I_C @ T_C = 25^\circ C$	Continuous Collector Current	20	A	$V_{GE} = 5V$
$I_C @ T_C = 110^\circ C$	Continuous Collector Current	14	A	$V_{GE} = 5V$
I_G	Continuous Gate Current	1	mA	
I_{Gp}	Peak Gate Current	10	mA	$t_{PK} = 1ms, f = 100Hz$
V_{GE}	Gate-to-Emitter Voltage	Clamped	V	
$P_D @ T_C = 25^\circ C$	Maximum Power Dissipation	125	W	
$P_D @ T = 110^\circ C$	Maximum Power Dissipation	54	W	
T_J	Operating Junction and	- 40 to 175	$^\circ C$	
T_{STG}	Storage Temperature Range	- 40 to 175	$^\circ C$	
V_{ESD}	Electrostatic Voltage	6	KV	$C = 100pF, R = 1.5K \text{ ohm}$
I_L	Self-clamped Inductive Switching Current	11.5	A	$L = 4.7mH, T = 25^\circ C$

Thermal Resistance

	Parameter	Min	Typ	Max	Unit
$R_{\theta JC}$	Thermal Resistance, Junction-to-Case			1.2	$^\circ C/W$
$R_{\theta JA}$	Thermal Resistance, Junction-to-Ambient			40	
	(PCB Mounted, Steady State)				
$Z_{\theta JC}$	Transient Thermal Impedance, Junction-to-Case (Fig.11)				

Off-State Electrical Characteristics @ $T_J = 25^\circ\text{C}$ (unless otherwise specified)

	Parameter	Min	Typ	Max	Unit	Conditions	Fig
BV_{CES}	Collector-to-Emitter Breakdown Voltage	370	400	430	V	$R_G = 1\text{K ohm}$, $I_C = 7\text{A}$, $V_{GE} = 0\text{V}$	
BV_{GES}	Gate-to-Emitter Breakdown Voltage	10	12		V	$I_G = 2\text{m A}$	
I_{CES}	Collector-to-Emitter Leakage Current			15	μA	$R_G = 1\text{K ohm}$, $V_{CE} = 250\text{V}$	
				100	μA	$R_G = 1\text{K ohm}$, $V_{CE} = 250\text{V}$, $T_J = 150^\circ\text{C}$	
BV_{CER}	Emitter-to-Collector Breakdown Voltage	24	28		V	$I_C = -10\text{m A}$	
R_1	Gate Series Resistance		75		ohm		
R_2	Gate-to-Emitter Resistance	10	20	30	K ohm		

On-State Electrical Characteristics @ $T_J = 25^\circ\text{C}$ (unless otherwise specified)

	Parameter	Min	Typ	Max	Unit	Conditions	Fig
$V_{CE(on)}$	Collector-to-Emitter Saturation Voltage		1.2	1.40	V	$I_C = 7\text{A}$, $V_{GE} = 4.5\text{V}$	1
			1.35	1.55		$I_C = 10\text{A}$, $V_{GE} = 4.5\text{V}$	
			1.35	1.55		$I_C = 10\text{A}$, $V_{GE} = 4.5\text{V}$, $T_C = -40^\circ\text{C}$	4
			1.5	1.7		$I_C = 14\text{A}$, $V_{GE} = 5.0\text{V}$, $T_C = -40^\circ\text{C}$	
			1.55	1.75		$I_C = 14\text{A}$, $V_{GE} = 5.0\text{V}$	
			1.6	1.8		$I_C = 14\text{A}$, $V_{GE} = 5.0\text{V}$, $T_C = 150^\circ\text{C}$	
$V_{GE(th)}$	Gate Threshold Voltage	1.3	1.8	2.2	V	$V_{CE} = V_{GE}$, $I_C = 1\text{ m A}$, $T_C = 25^\circ\text{C}$	3, 5
		0.75		1.8		$V_{CE} = V_{GE}$, $I_C = 1\text{ m A}$, $T_C = 150^\circ\text{C}$	
g_{fs}	Transconductance	10	15	19	S	$V_{CE} = 25\text{V}$, $I_C = 10\text{A}$, $T_C = 25^\circ\text{C}$	
I_C	Collector Current	20			A	$V_{CE} = 10\text{V}$, $V_{GE} = 4.5\text{V}$	

Switching Characteristics @ $T_J = 25^\circ\text{C}$ (unless otherwise specified)

	Parameter	Min	Typ	Max	Unit	Conditions	Fig
Q_g	Total Gate charge		27		nC	$I_C = 10\text{A}$, $V_{CE} = 12\text{V}$, $V_{GE} = 5\text{V}$	7
Q_{ge}	Gate - Emitter Charge		2.5			$I_C = 10\text{A}$, $V_{CE} = 12\text{V}$, $V_{GE} = 5\text{V}$	15
Q_{gc}	Gate - Collector Charge		10			$I_C = 10\text{A}$, $V_{CE} = 12\text{V}$, $V_{GE} = 5\text{V}$	
$t_{d(on)}$	Turn - on delay time	0.6	0.9	1.35	μs	$V_{GE} = 5\text{V}$, $R_G = 1\text{K ohm}$, $L = 1\text{mH}$, $V_{CE} = 14\text{V}$	12
t_r	Rise time	1.6	2.8	4		$V_{GE} = 5\text{V}$, $R_G = 1\text{K ohm}$, $L = 1\text{mH}$, $V_{CE} = 14\text{V}$	14
$t_{d(off)}$	Turn - off delay time	3.7	6	8.3		$V_{GE} = 5\text{V}$, $R_G = 1\text{K ohm}$, $L = 1\text{mH}$, $V_{CE} = 300\text{V}$	
C_{ies}	Input Capacitance		550	825	pF	$V_{GE} = 0\text{V}$, $V_{CE} = 25\text{V}$, $f = 1\text{M H z}$	6
C_{oes}	Output Capacitance		100	150		$V_{GE} = 0\text{V}$, $V_{CE} = 25\text{V}$, $f = 1\text{M H z}$	
C_{res}	Reverse Transfer Capacitance		12	18		$V_{GE} = 0\text{V}$, $V_{CE} = 25\text{V}$, $f = 1\text{M H z}$	
I_L	Self-Clamped Inductive Switching Current	25			A	$L = 0.7\text{m H}$, $T_C = 25^\circ\text{C}$	9
		15.5				$L = 2.2\text{m H}$, $T_C = 25^\circ\text{C}$	
		11.5				$L = 4.7\text{m H}$, $T_C = 25^\circ\text{C}$	10
		16.5				$L = 1.5\text{m H}$, $T_C = 150^\circ\text{C}$	13
		7.5				$L = 4.7\text{m H}$, $T_C = 150^\circ\text{C}$	
		6				$L = 8.7\text{m H}$, $T_C = 150^\circ\text{C}$	
t_{sc}	Short Circuit Withstand Time				μs	$T_J = 150^\circ\text{C}$, $V_{CC} = 16\text{V}$, $L = 10\mu\text{H}$ $R_G = 1\text{K ohm}$, $V_{GE} = 5\text{V}$	14
		120					

Fig.1 - Typ. Output Characteristics
 $T_J=25^\circ\text{C}$

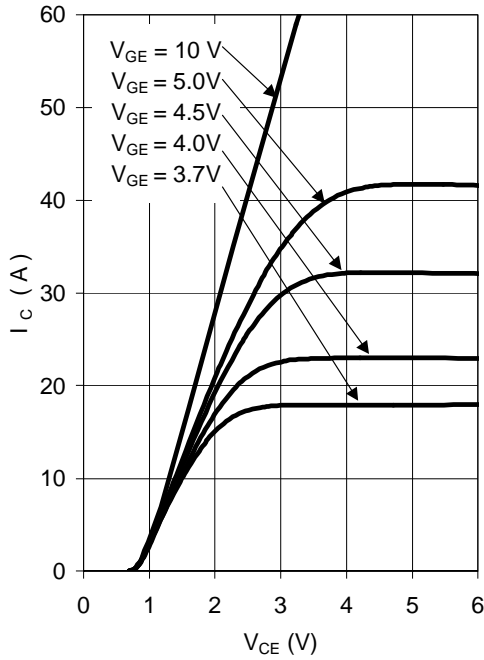

Fig.2 - Typ. Output Characteristics
 $T_J=125^\circ\text{C}$

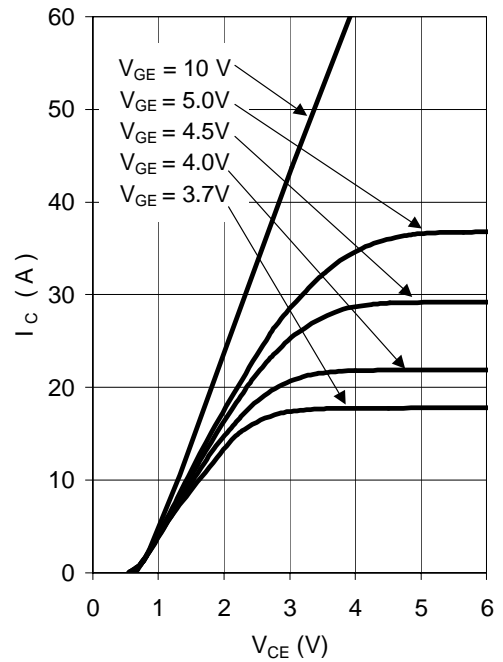

Fig.3 - Transfer Characteristics
 $V_{CE}=20\text{V}; t_p=20\mu\text{s}$

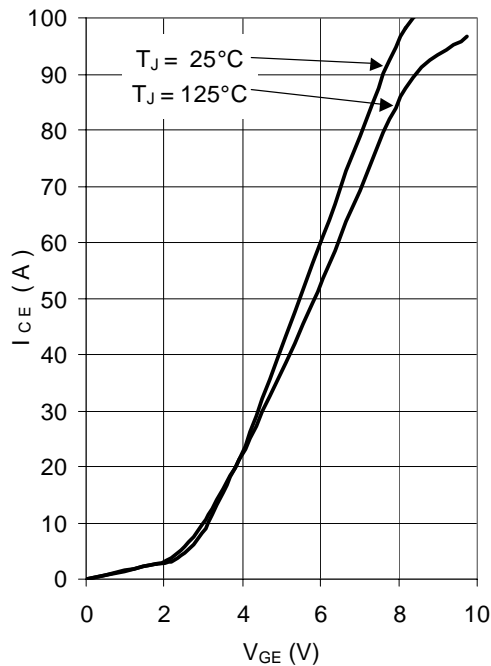
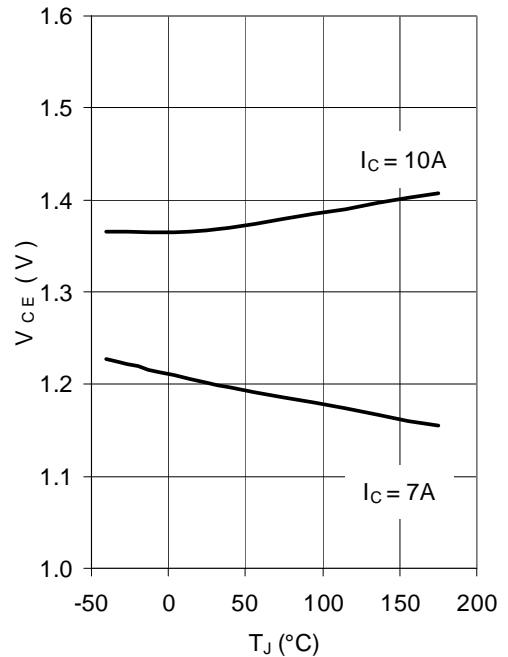

Fig.4 - Typical V_{CE} vs T_J
 $V_{GE}=4.5\text{V}$



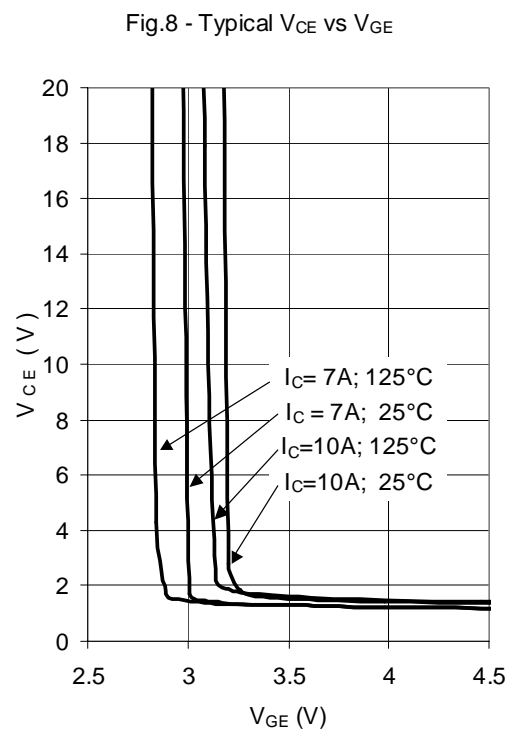
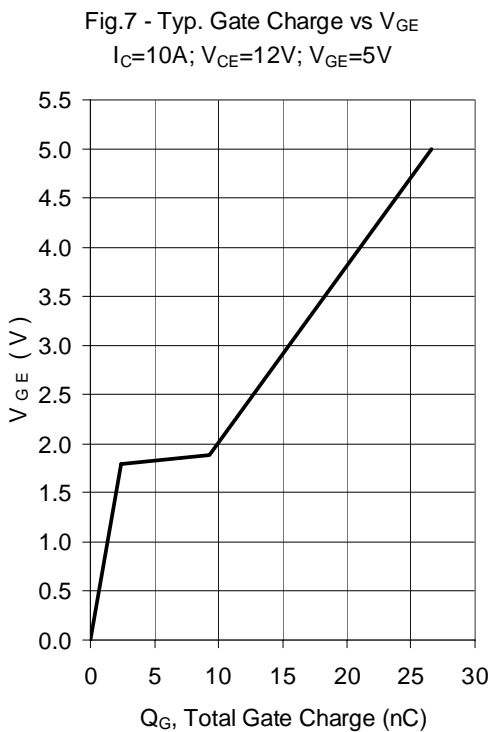
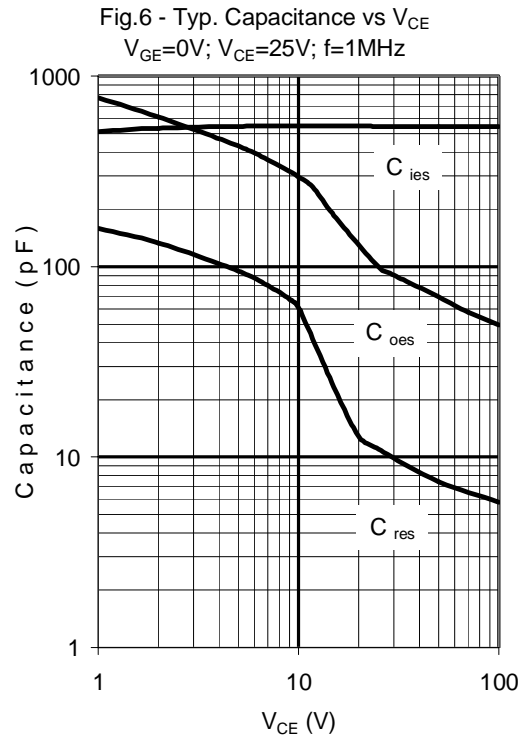
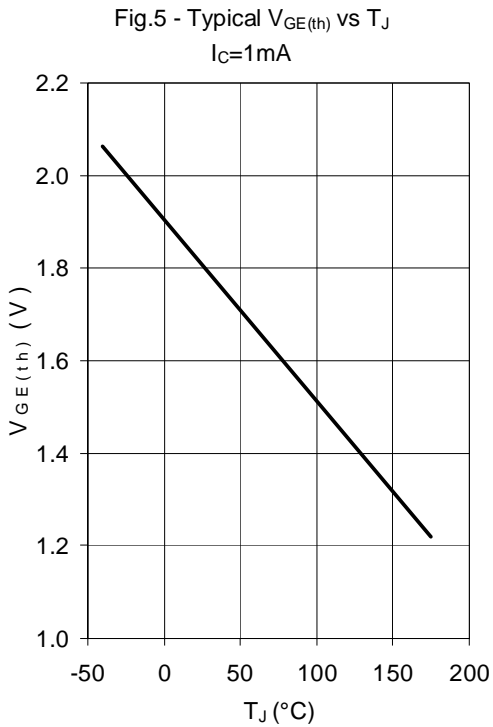

Fig.9 - Self-clamp Avalanche Current vs Inductance @ 25°C

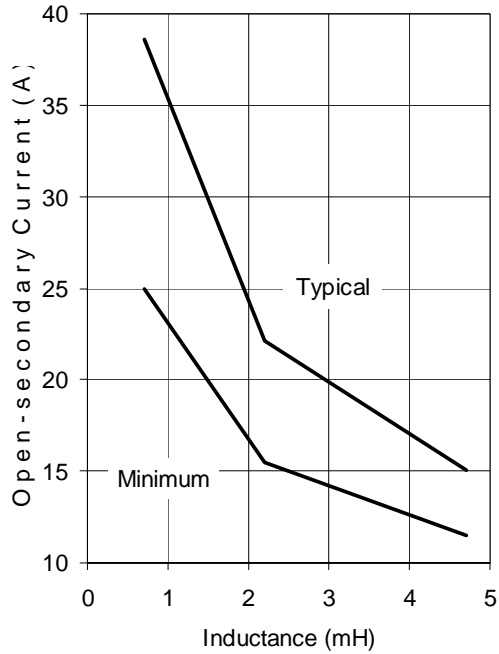

Fig.10 - Self-clamp Avalanche Current vs Inductance @ 150°C

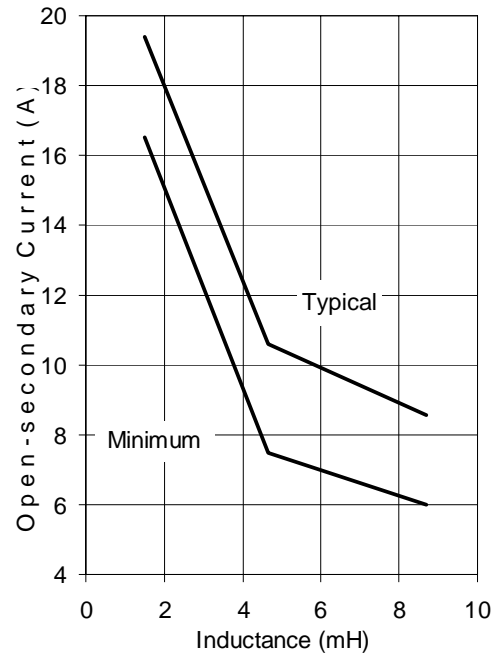

Fig.11 - Transient Thermal Impedance, Junction-to-Case

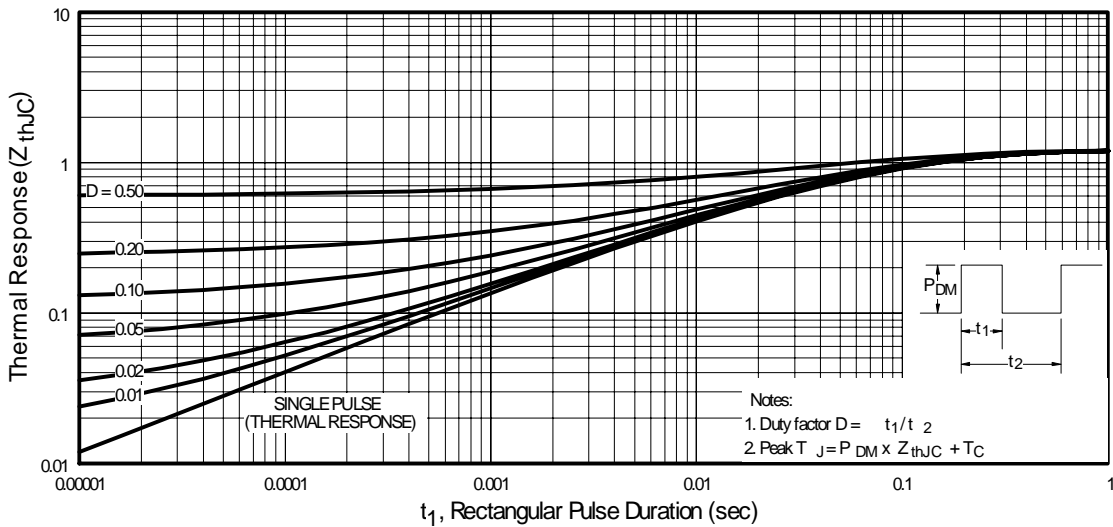

Fig.12 - Switching Waveform for Time Measurement

$V_{GE} = 5V$; $R_G = 1K\Omega$; $L = 1mH$; $V_{CE} = 14V$; used circuit in Fig.14

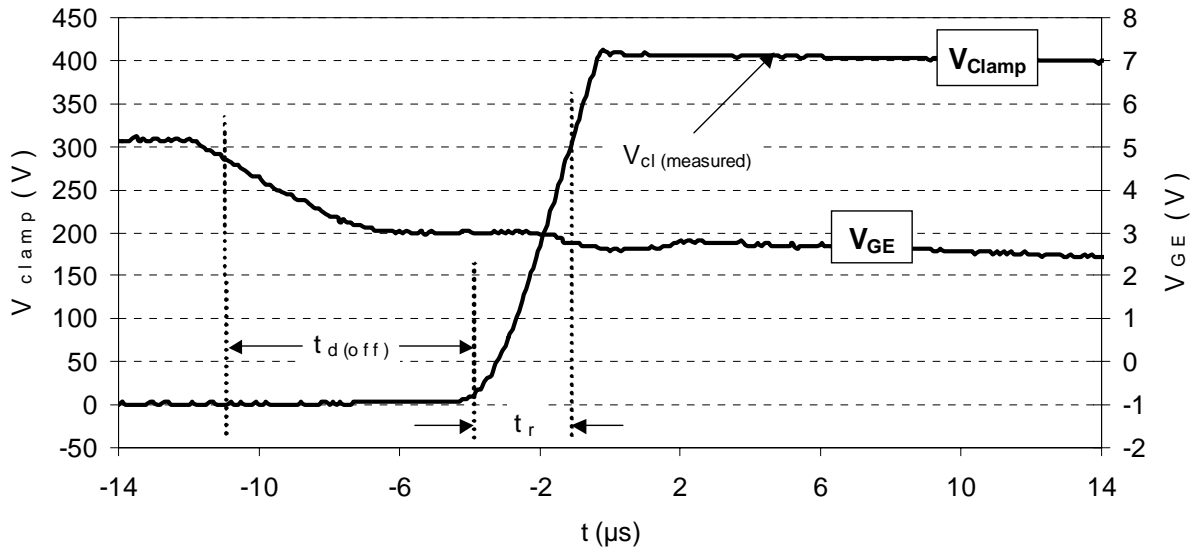

Fig.13 - Self-clamped Inductive Switching Waveform

$L = 4.7mH$; $T_C = 25^\circ C$; used circuit in Fig.14

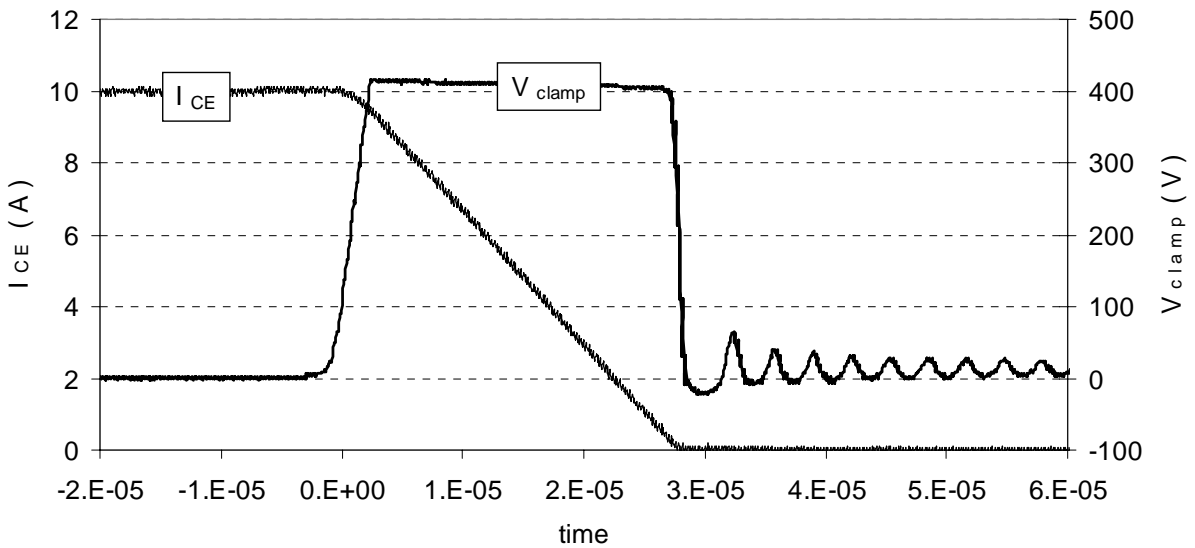

Fig.14 - Test Circuit

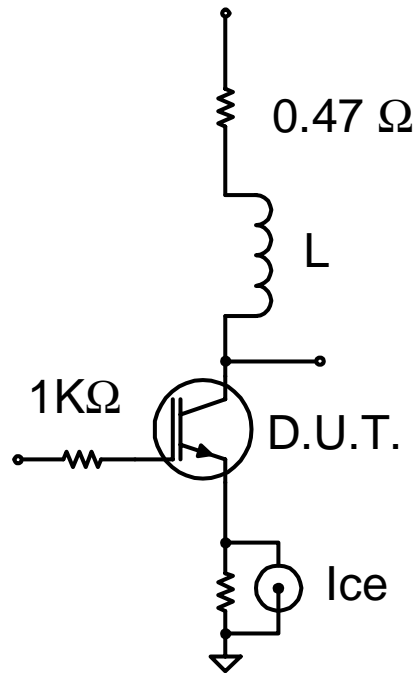
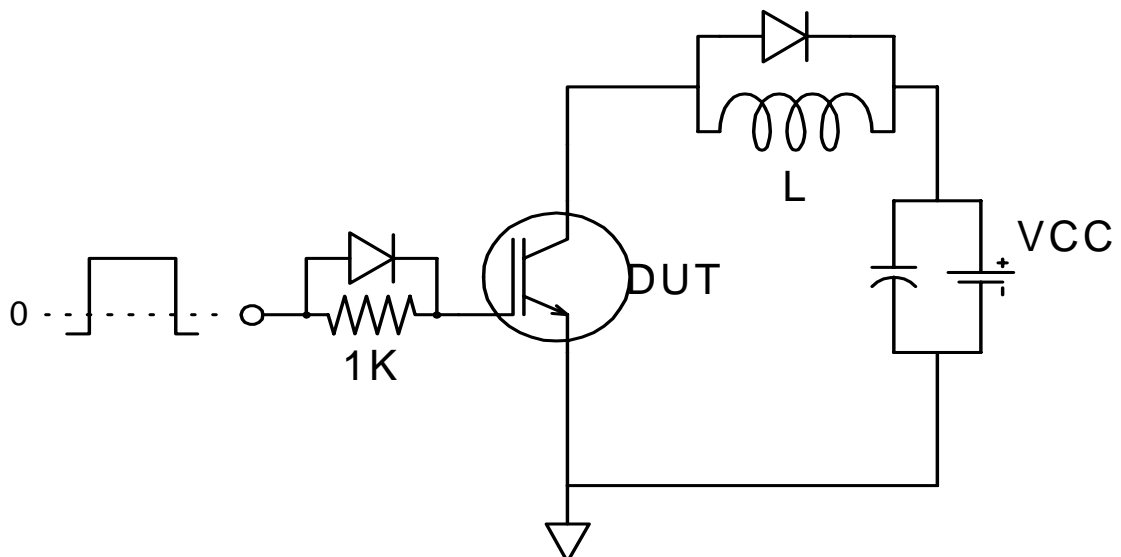
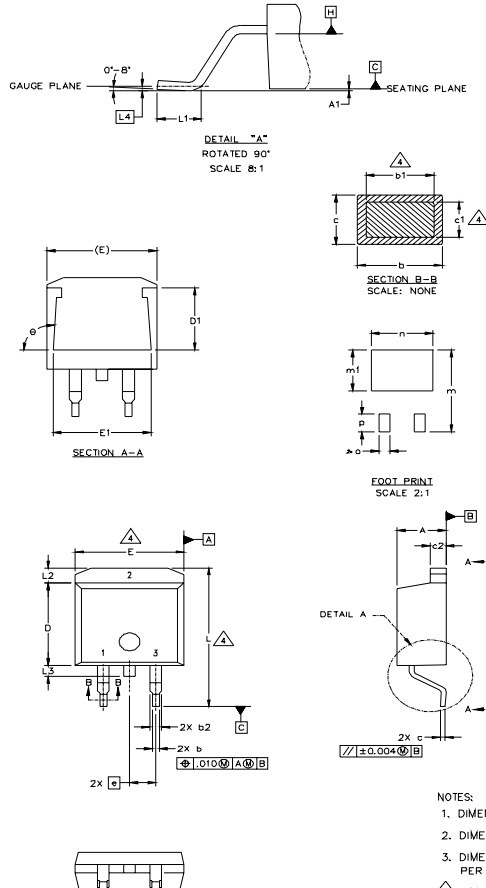

Fig.15 - Gate Charge Circuit



D²Pak Package Outline

Dimensions are shown in millimeters (inches)



SYMBOL	DIMENSIONS				NOTES
	MILLIMETERS		INCHES		
	MIN.	MAX.	MIN.	MAX.	
A	4.06	4.83	.160	.190	4
A1	0.127	0.127	.005	.005	
b	0.51	0.99	.020	.039	
b1	0.51	0.89	.020	.035	
b2	1.14	1.40	.045	.055	4
c	0.43	0.63	.017	.025	
c1	0.38	0.74	.015	.029	3
c2	1.14	1.40	.045	.055	
D	8.51	9.65	.335	.380	3
D1	5.33		.210		
E	9.65	10.67	.380	.420	3
E1	6.22		.245		
e	2.54	BSC	.100	BSC	
L	14.61	15.88	.575	.625	
L1	1.78	2.79	.070	.110	
L2		1.65		.065	
L3	1.27	1.78	.050	.070	
L4	0.25	BSC	.010	BSC	
m	17.78		.700		
m1	8.89		.350		
n	11.43		.450		
o	2.08		.082		
p	3.81		.150		
θ	90°	93°	90°	93°	

LEAD ASSIGNMENTS

HEXFET	IGBTs, CoPACK	DIODES
1.- GATE	1.- GATE	1.- ANODE *
2.- DRAIN	2.- COLLECTOR	2.- CATHODE
3.- SOURCE	3.- EMITTER	3.- ANODE

* PART DEPENDENT.

NOTES:

1. DIMENSIONING AND TOLERANCING PER ASME Y14.5M-1994
2. DIMENSIONS ARE SHOWN IN MILLIMETERS [INCHES].
3. DIMENSION D & E DO NOT INCLUDE MOLD FLASH. MOLD FLASH SHALL NOT EXCEED 0.127 [.005"] PER SIDE. THESE DIMENSIONS ARE MEASURED AT THE OUTMOST EXTREMES OF THE PLASTIC BODY.
4. DIMENSION b1 AND c1 APPLY TO BASE METAL ONLY.
5. CONTROLLING DIMENSION: INCH.

D²Pak Part Marking Information (Lead-Free)

EXAMPLE: THIS IS AN IRF530S WITH
LOT CODE 8024
ASSEMBLED ON WW 02, 2000
IN THE ASSEMBLY LINE "L"

Note: "P" in assembly line
position indicates "Lead-Free"

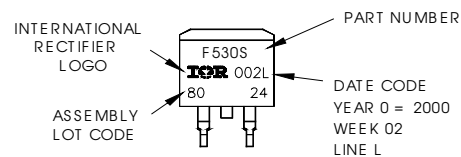

OR

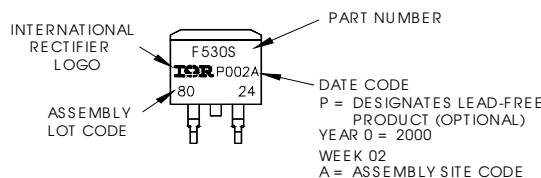

TO-262 Package Outline

Dimensions are shown in millimeters (inches)

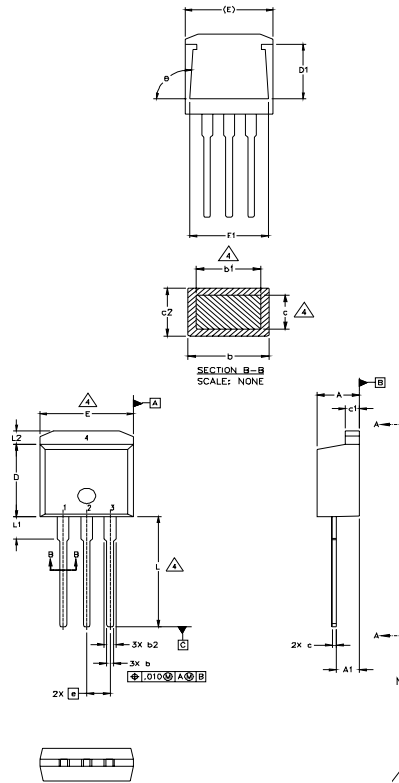

SYMBOL	DIMENSIONS				NOTES
	MILLIMETERS		INCHES		
	MIN.	MAX.	MIN.	MAX.	
A	4.06	4.83	.160	.190	
A1	2.03	2.92	.080	.115	
b	0.51	0.99	.020	.039	
b1	0.51	0.89	.020	.035	4
b2	1.14	1.40	.045	.055	
c	0.38	0.63	.015	.025	4
c1	1.14	1.40	.045	.055	
c2	0.43	.063	.017	.029	
D	8.51	9.65	.335	.380	3
D1	5.33		.210		
E	9.65	10.67	.380	.420	3
E1	6.22		.245		
e	2.54	BSC	.100	BSC	
L	13.46	14.09	.530	.555	
L1	3.56	3.71	.140	.146	
L2		1.65		.065	

LEAD ASSIGNMENTS

HEXFET	IGBT
1.- GATE	1 - GATE
2.- DRAIN	2 - COLLECTOR
3.- SOURCE	3 - EMITTER
4.- DRAIN	

- NOTES:
1. DIMENSIONING AND TOLERANCING PER ASME Y14.5M-1994
 2. DIMENSIONS ARE SHOWN IN MILLIMETERS [INCHES].
 3. DIMENSION D & E DO NOT INCLUDE MOLD FLASH. MOLD FLASH SHALL NOT EXCEED 0.127 [.005"] PER SIDE. THESE DIMENSIONS ARE MEASURED AT THE OUTMOST EXTREMES OF THE PLASTIC BODY.
 4. DIMENSION b1 AND c1 APPLY TO BASE METAL ONLY.
 5. CONTROLLING DIMENSION: INCH.

TO-262 Part Marking Information

EXAMPLE: THIS IS AN IRL3103L
LOT CODE 1789
ASSEMBLED ON WW 19, 1997
IN THE ASSEMBLY LINE "C"

Note: "P" in assembly line position indicates "Lead-Free"

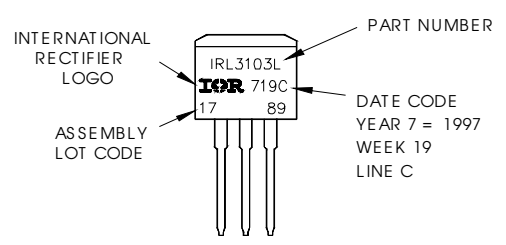

OR

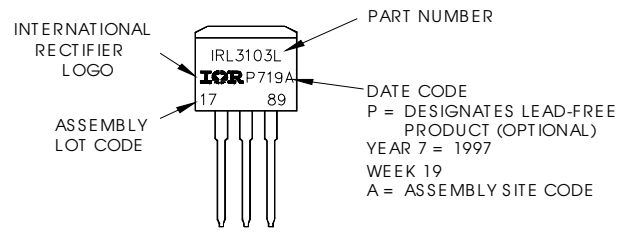

TO-220AB Package Outline

Dimensions are shown in millimeters (inches)

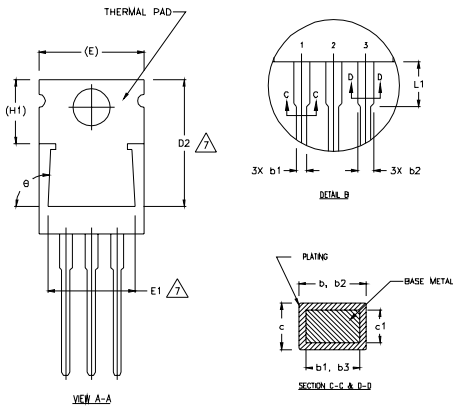
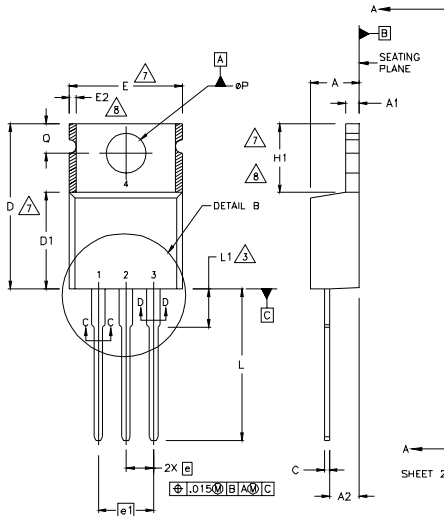

NOTES:

- 1 DIMENSIONING AND TOLERANCING PER ASME Y14.5 M- 1994.
- 2 DIMENSIONS ARE SHOWN IN INCHES [MILLIMETERS].
- 3 LEAD DIMENSION AND FINISH UNCONTROLLED IN L1.
- 4 DIMENSION D & E DO NOT INCLUDE MOLD FLASH. MOLD FLASH SHALL NOT EXCEED .005" (0.127) PER SIDE. THESE DIMENSIONS ARE MEASURED AT THE OUTERMOST EXTREMES OF THE PLASTIC BODY.
- 5 DIMENSION b1 & c1 APPLY TO BASE METAL ONLY.
- 6 CONTROLLING DIMENSION ; INCHES.
- 7 THERMAL PAD CONTOUR OPTIONAL WITHIN DIMENSIONS E,H1,D2 & E1
- 8 DIMENSION E2 X H1 DEFINE A ZONE WHERE STAMPING AND SINGULATION IRREGULARITIES ARE ALLOWED.

LEAD ASSIGNMENTS

HEXFEET

- 1.- GATE
- 2.- DRAN
- 3.- SOURCE

IGBTs, CoPACK

- 1.- GATE
- 2.- COLLECTOR
- 3.- EMITTER

DIODES

- 1.- ANODE/OPEN
- 2.- CATHODE
- 3.- ANODE

SYMBOL	DIMENSIONS				NOTES
	MILLIMETERS		INCHES		
	MIN.	MAX.	MIN.	MAX.	
A	3.56	4.82	.140	.190	
A1	0.51	1.40	.020	.055	
A2	2.04	2.92	.080	.115	
b	0.38	1.01	.015	.040	
b1	0.38	0.96	.015	.038	5
b2	1.15	1.77	.045	.070	
b3	1.15	1.73	.045	.068	
c	0.36	0.61	.014	.024	
c1	0.36	0.56	.014	.022	5
D	14.22	16.51	.560	.650	4
D1	8.38	9.02	.330	.355	
D2	12.19	12.88	.480	.507	7
E	9.66	10.66	.380	.420	4,7
E1	8.38	8.89	.330	.350	7
e	2.54 BSC		.100 BSC		
e1	5.08		.200 BSC		
H1	5.85	6.55	.230	.270	7,8
L	12.70	14.73	.500	.580	
L1	-	6.35	-	.250	3
øP	3.54	4.08	.139	.161	
Q	2.54	3.42	.100	.135	
ø	90°-93°		90°-93°		

TO-220AB Part Marking Information

EXAMPLE: THIS IS AN IRF1010
 LOT CODE 1789
 ASSEMBLED ON WW 19, 1997
 IN THE ASSEMBLY LINE "C"
Note: "P" in assembly line position indicates "Lead-Free"

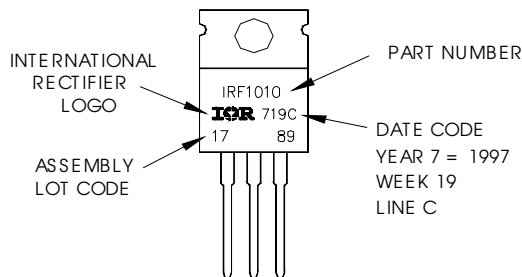

D²Pak Tape & Reel Information

Dimensions are shown in millimeters (inches)

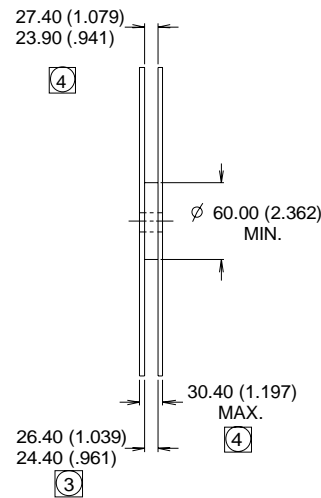
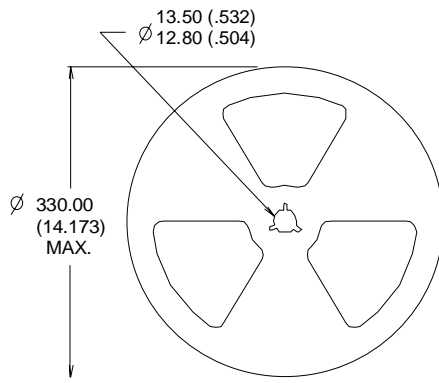
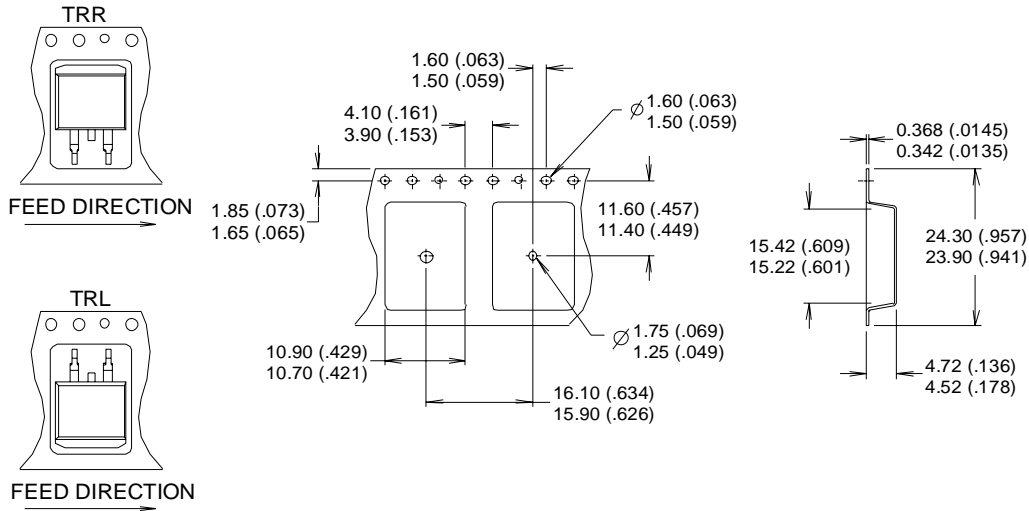

- NOTES :
1. COMFORMS TO EIA-418.
 2. CONTROLLING DIMENSION: MILLIMETER.
 - ③ DIMENSION MEASURED @ HUB.
 - ④ INCLUDES FLANGE DISTORTION @ OUTER EDGE.

Data and specifications subject to change without notice.

Note: For the most current drawings please refer to the IR website at:
<http://www.irf.com/package/>