

THIS DRAWING IS UNPUBLISHED. RELEASED FOR PUBLICATION  
 © COPYRIGHT - By - ALL RIGHTS RESERVED.

REVISIONS					
P	LTR	DESCRIPTION	DATE	DWN	APVD
	H1	REVISED PER ECN-21-119059	05APR2022	AK	SZ

Standardausführung: V23529-Bx121-Bxxx-+  
 Standardversion

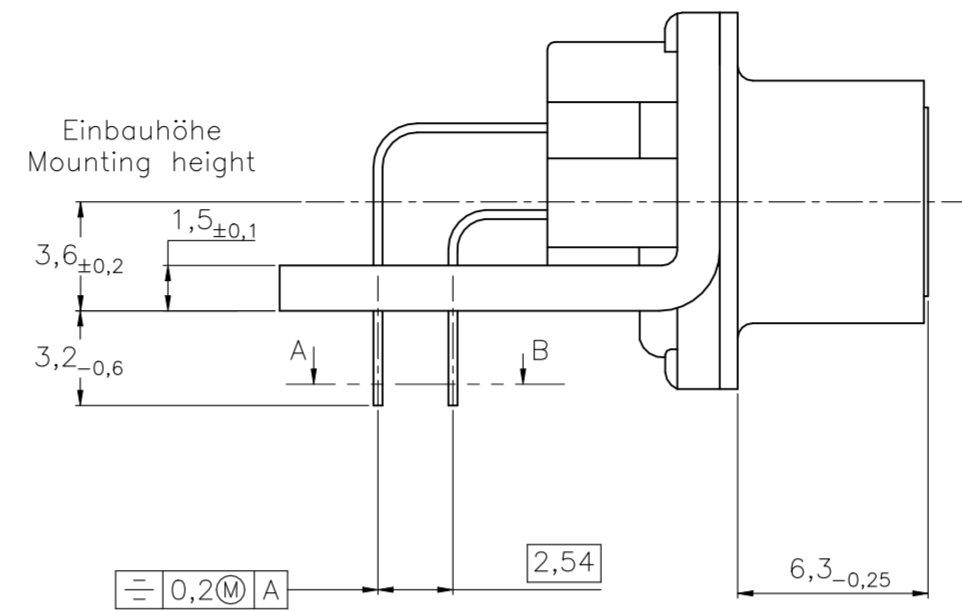
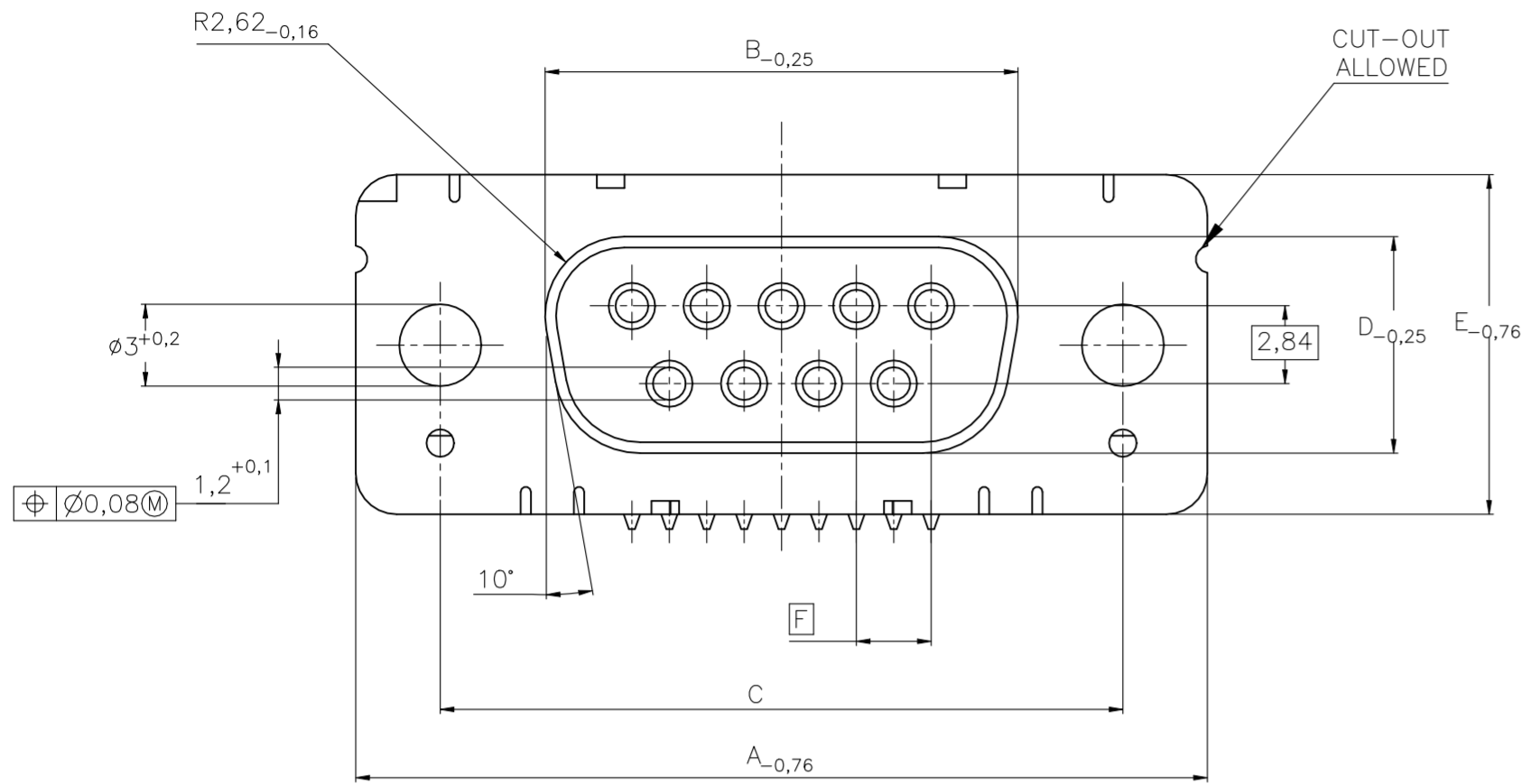

Schnitt AB des Lötanschlusses  
 Cross-section AB of solderpin  
 (20:1)

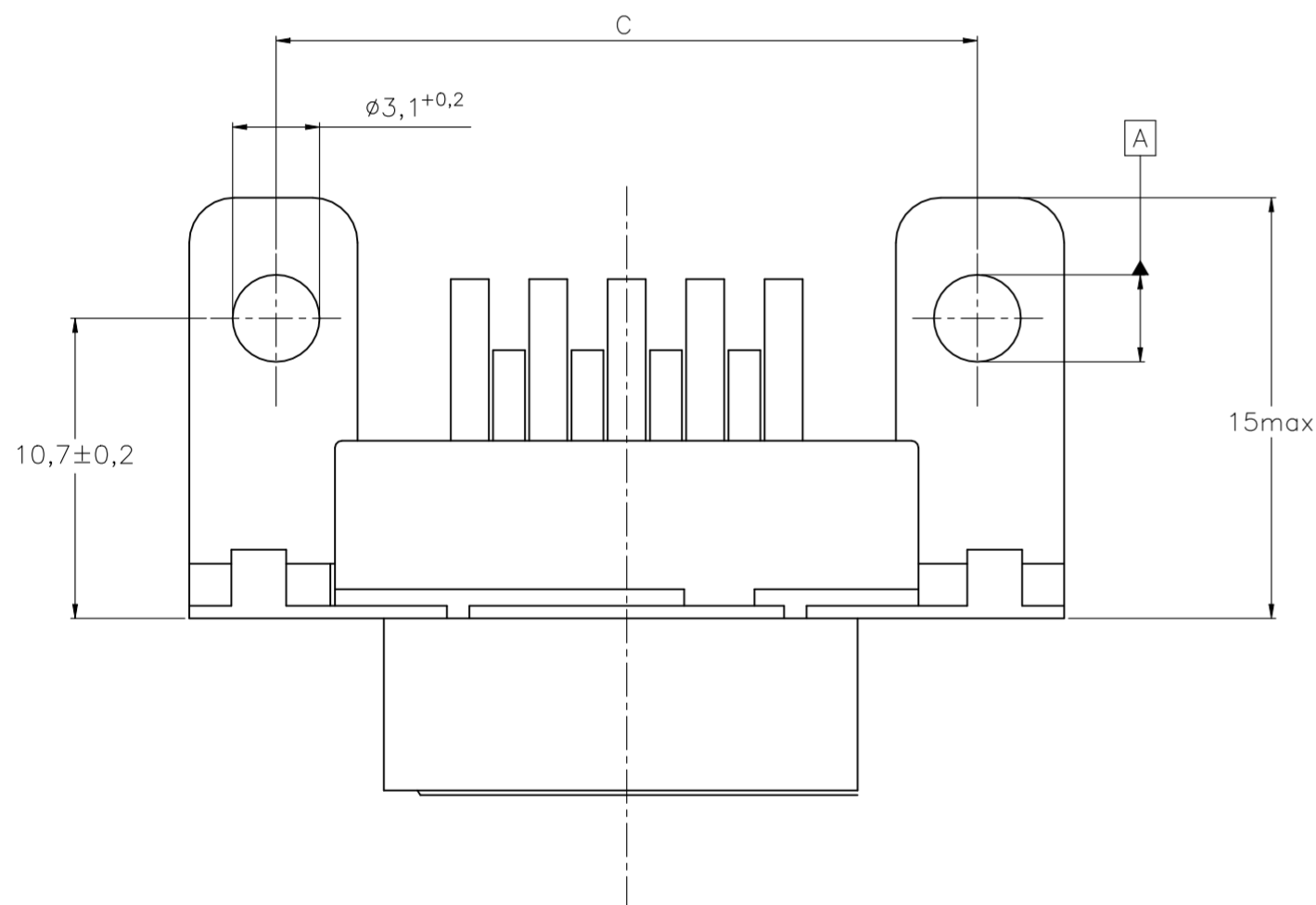
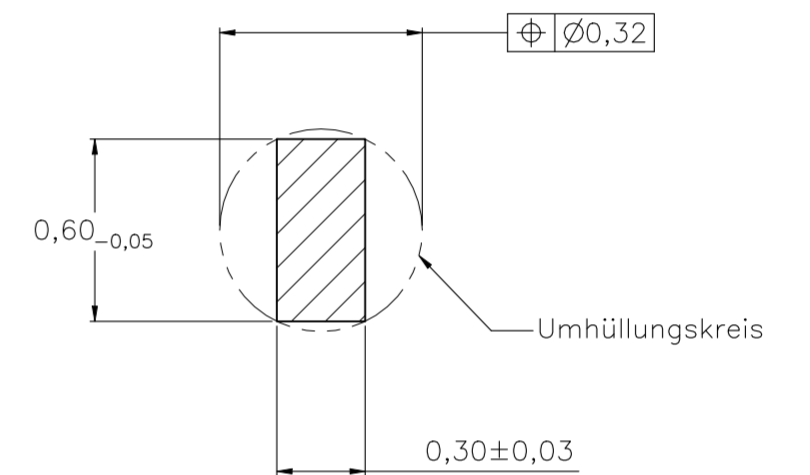

Ordercode Sachnr	Contacts Polzahl	Mass/Dimension					
		A	B	C	D	E	F
..-Bx09-+	09	31,19	16,46	25,0 $\begin{smallmatrix} +0,12 \\ -0,13 \end{smallmatrix}$	8,02	12,93	2,74
..-Bx15-+	15	39,52	24,79	33,3 $\begin{smallmatrix} +0,15 \\ -0,1 \end{smallmatrix}$			2,74
..-Bx25-+	25	53,42	38,5	47,04 $\begin{smallmatrix} +0,13 \\ -0,13 \end{smallmatrix}$			2,76
..-Bx37-+	37	69,7	54,96	63,5 $\begin{smallmatrix} +0,13 \\ -0,13 \end{smallmatrix}$			2,76

Anforderungsstufe/Performance level <sup>1)</sup>

1) nach DIN 41652T.2 und T.4  
 according to DIN 41652 T.2 AND T.4

OLD PN: V23529-B\*\*\*\*-B\*\*\*-\*-7427

THIS DRAWING IS A CONTROLLED DOCUMENT.		DWN GNANI JADAV A E	07JAN10	<b>STE</b> TE Connectivity	
DIMENSIONS: mm		CHK K. MALCZYK			
TOLERANCES UNLESS OTHERWISE SPECIFIED:		APVD K. MALCZYK		NAME Buchsenleiste <sup>1)</sup> Einbauhöhe 3,6 mm (Variante 1) Socketconnector-90° solderversion (Type1) <sup>1)</sup>	
0 PLC ± - 1 PLC ± - 2 PLC ± - 3 PLC ± - 4 PLC ± - ANGLES ± -		PRODUCT SPEC		SIZE A2	CAGE CODE 00779
MATERIAL		FINISH		DRAWING NO C=1-1393480-7	RESTRICTED TO
		WEIGHT 0		SCALE 2:1	SHEET 1 of 6
		CUSTOMER DRAWING		REV H1	

REVISIONS					
P	LTR	DESCRIPTION	DATE	DWN	APVD
-	-	SEE SHEET 1	-	-	-

mit Gewindebolzen: M3 V23529-Bxx24-Bxxx-+  
 with threadlock 4-40 UNC V23529-Bxx25-Bxxx-+

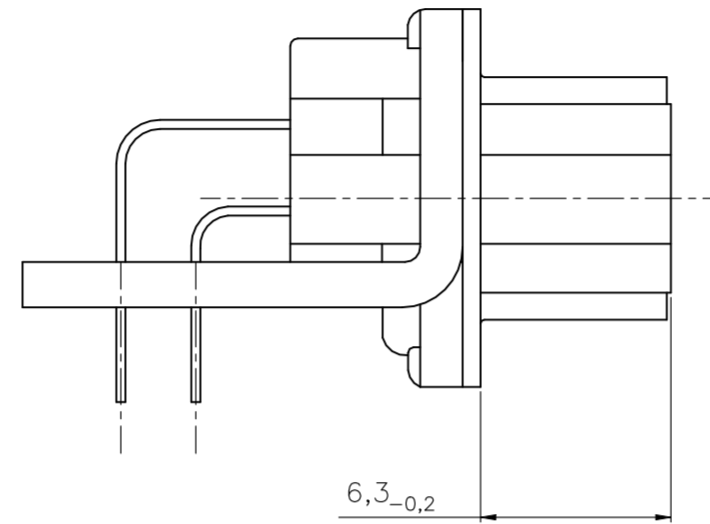
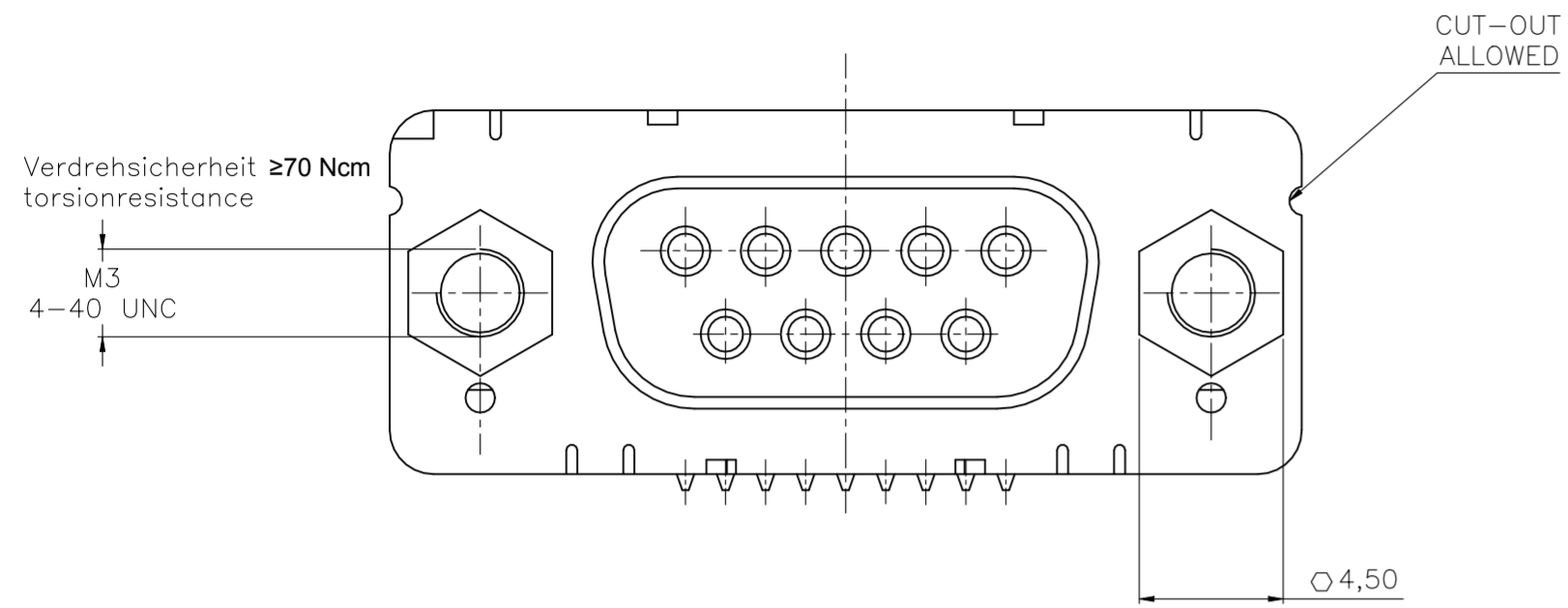

Leiterplattenbohrung  
PCB hole pattern

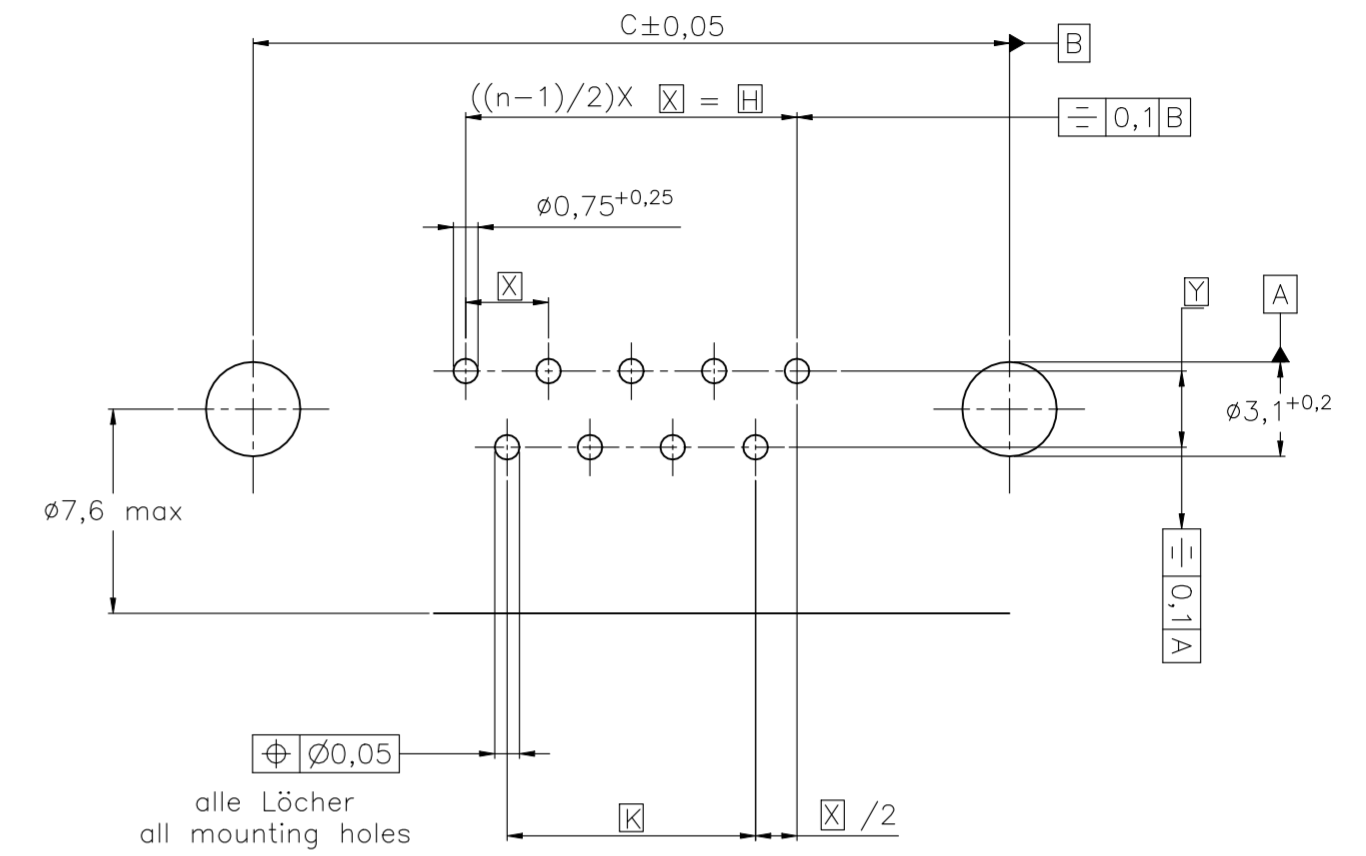

mit Gewinde : M3 V23529-Bxx22-Bxxx-+  
 with thread 4-40 UNC V23529-Bxx23-Bxxx-+

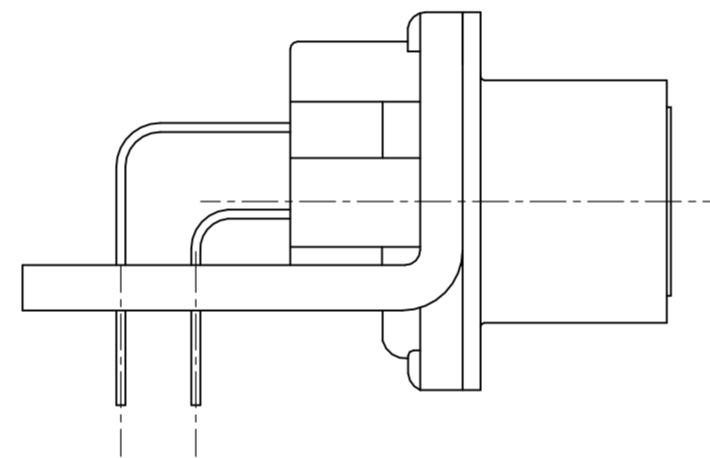
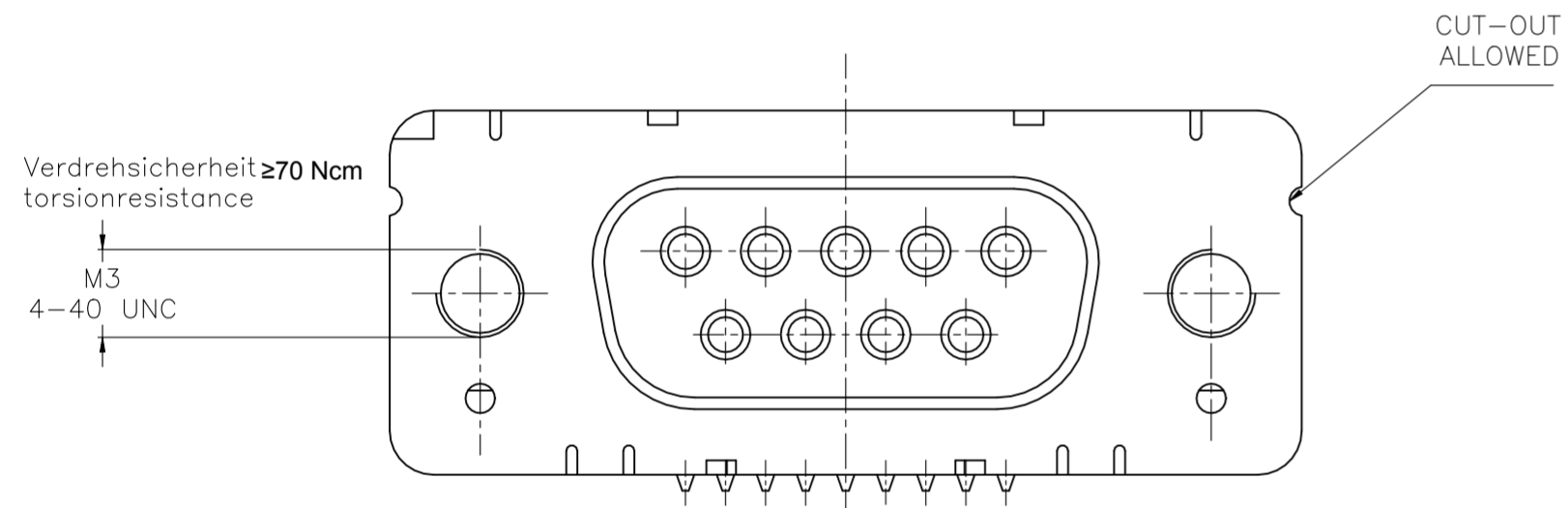

Mass Dimension	Polzahl n Number of contacts n			
	9	15	25	37
C	25	33,3	47,04	63,5
H	10,96	19,18	33,12	49,68
K	8,22	16,44	30,36	46,92
X	2,74	2,74	2,76	2,76
Y	2,54			

1) nach DIN 41652.T.2 und T.4  
 according to DIN 41652 T.2 AND T.4

mit clipbefestigung V23529-Bx22x-Bxxx-+  
 with snap-in

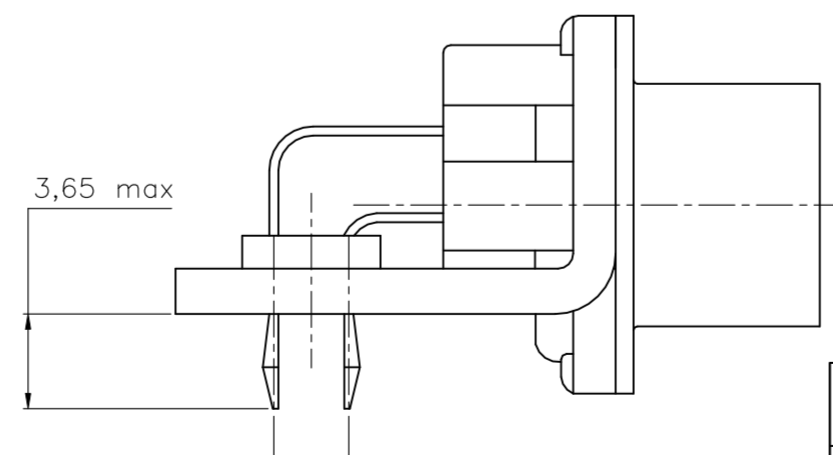
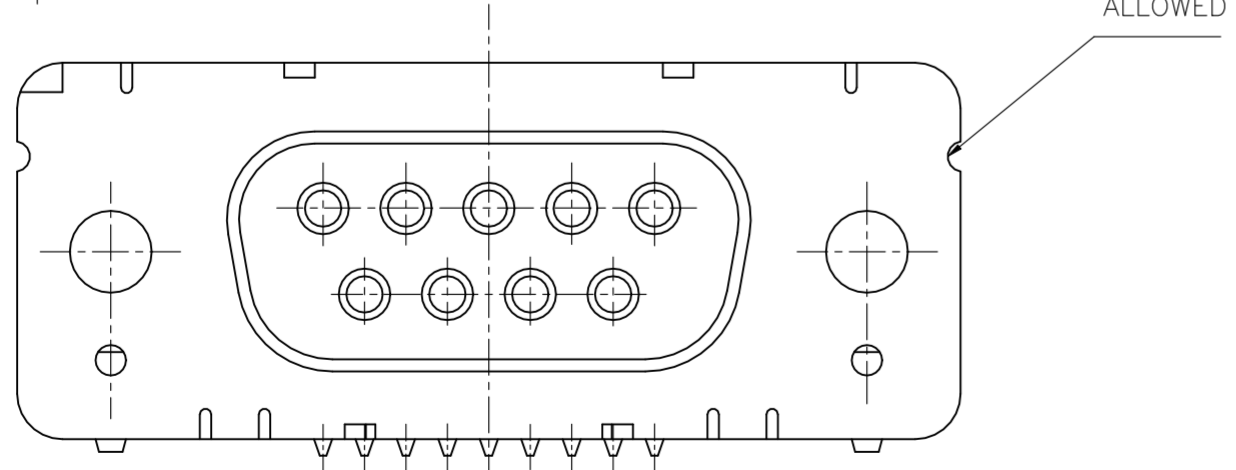

LP-Dicke 1,6±0,13mm, Loch  $\phi 3,1^{+0,2}$   
 PC-board-thickness 1,6±0,13mm, Hole  $\phi 3,1^{+0,2}$

OLD PN: V23529-B\*\*\*\*\*-B\*\*\*-\*-7427

THIS DRAWING IS A CONTROLLED DOCUMENT.		DWN GNANI JADAV A E 07JAN10	TE Connectivity	
DIMENSIONS: mm		CHK K. MALCZYK		
TOLERANCES UNLESS OTHERWISE SPECIFIED:		APVD K. MALCZYK	Buchsenleiste 1) Einbauhöhe 3,6 mm (Variante 1) Socketconnector-90° solderversion (Type1) <sup>1)</sup>	
0 PLC ± - 1 PLC ± - 2 PLC ± - 3 PLC ± - 4 PLC ± - ANGLES ± -		PRODUCT SPEC	SIZE	RESTRICTED TO
MATERIAL		APPLICATION SPEC	CAGE CODE	DRAWING NO
FINISH		WEIGHT	A2 00779	C=1-1393480-7
		CUSTOMER DRAWING	SCALE 2:1	SHEET 2 of 6
			REV H1	

THIS DRAWING IS UNPUBLISHED. RELEASED FOR PUBLICATION  
 © COPYRIGHT - By - ALL RIGHTS RESERVED.

REVISIONS					
P	LTR	DESCRIPTION	DATE	DWN	APVD
-	-	SEE SHEET 1	-	-	-

Standardausführung ohne Winkel: V23529-B50x1-Bxxx-+  
 Standardversion without bracket

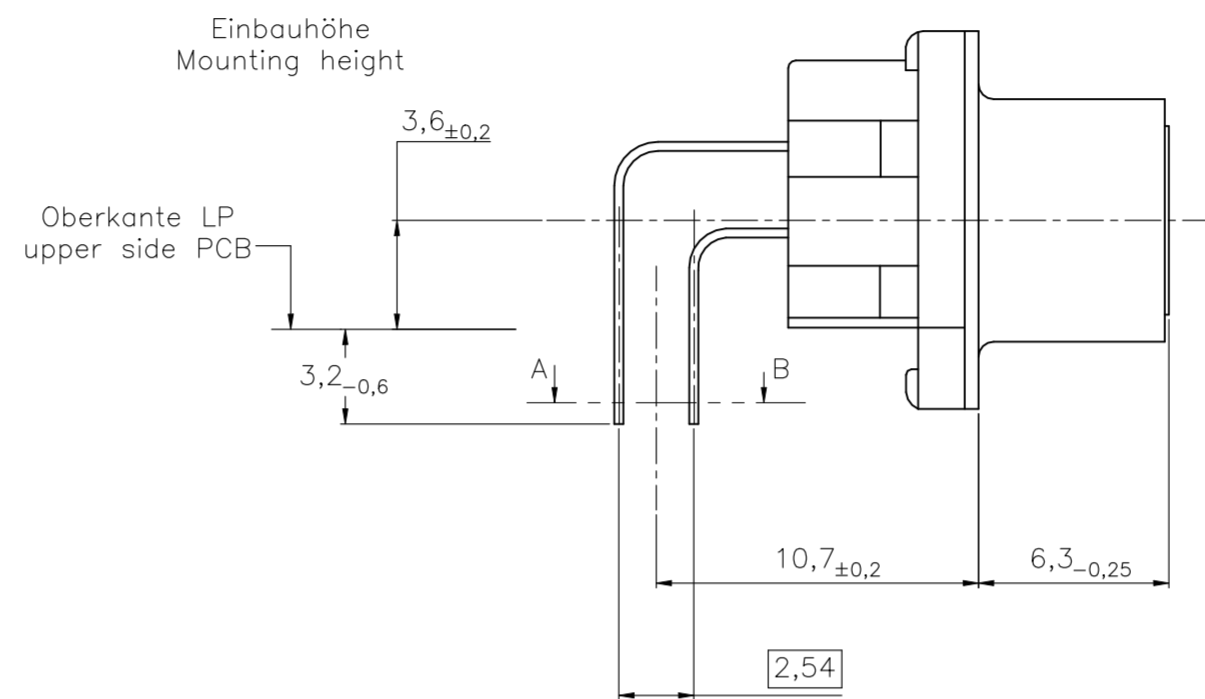
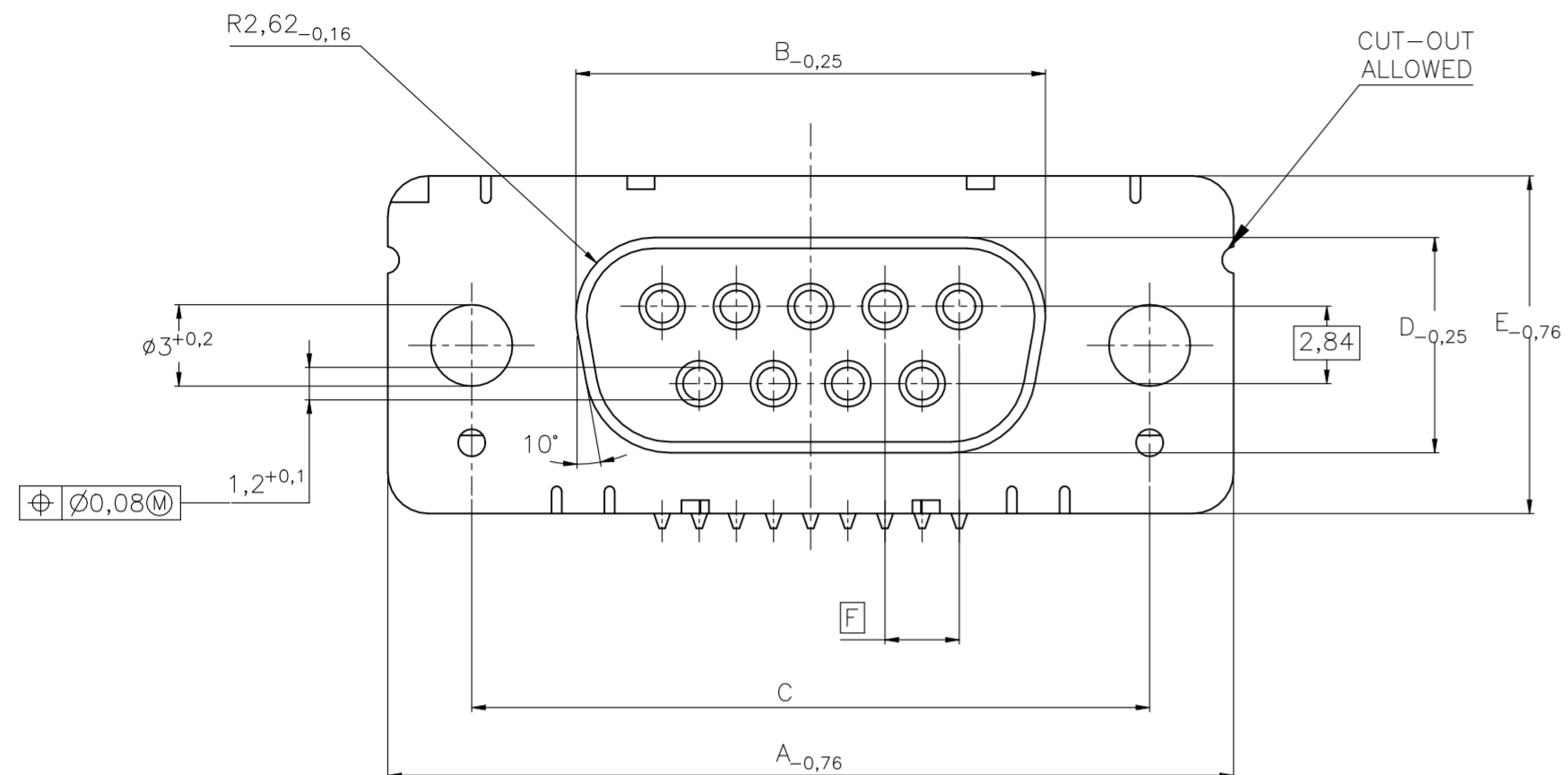

Schnitt AB des Lötanschlusses  
 Cross-section AB of solderpin  
 (20:1)

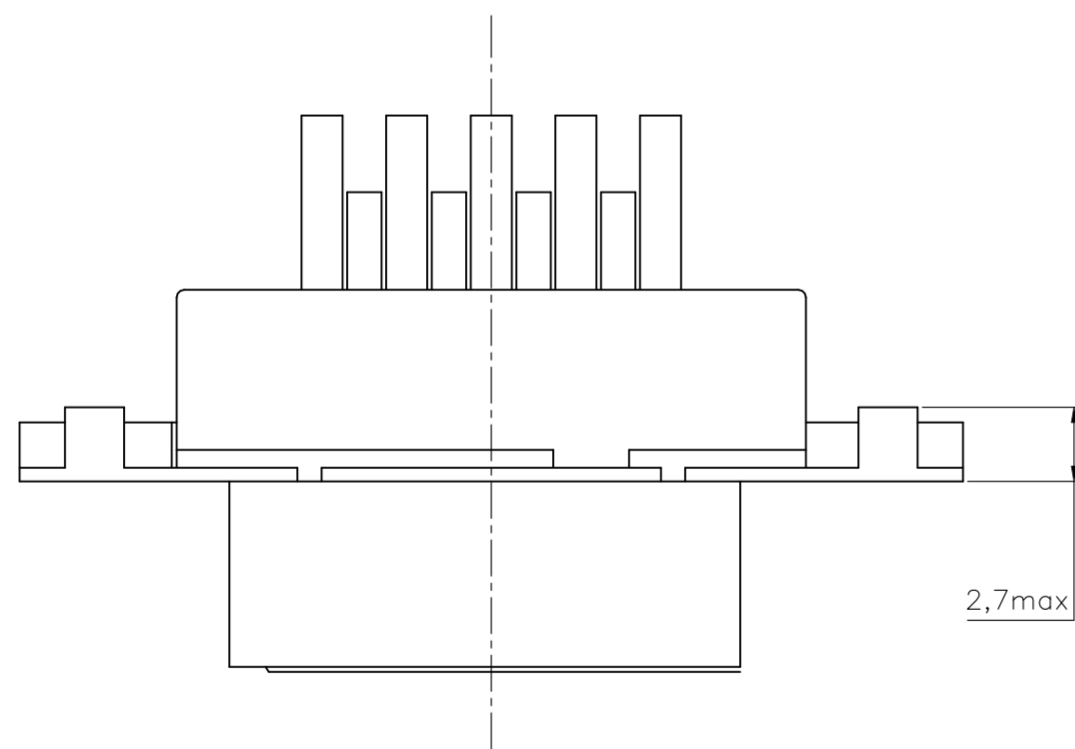
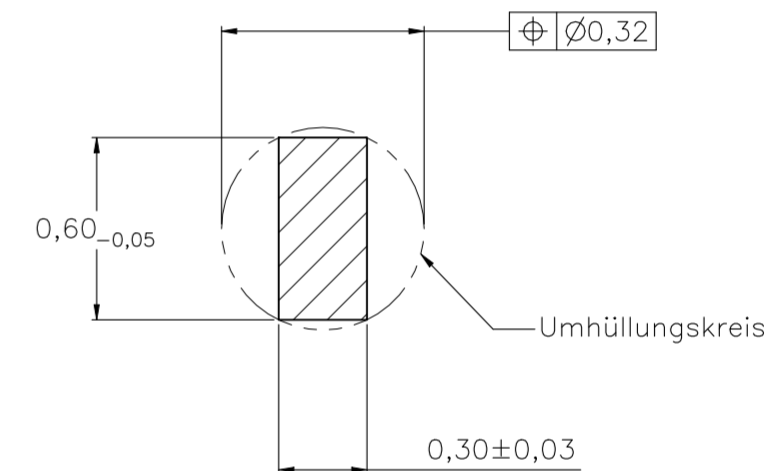

Ordercode Sachnr	Contacts Polzahl	Mass/Dimension					
		A	B	C	D	E	F
..-Bx09-+	09	31,19	16,46	25,0 <sup>+0,12</sup> <sub>-0,13</sub>	8,02	12,93	2,74
..-Bx15-+	15	39,52	24,79	33,3 <sup>+0,15</sup> <sub>-0,1</sub>			2,74
..-Bx25-+	25	53,42	38,5	47,04 <sup>+0,13</sup> <sub>-0,13</sub>			2,76
..-Bx37-+	37	69,7	54,96	63,5 <sup>+0,13</sup> <sub>-0,13</sub>			2,76

Anforderungsstufe/Performance level <sup>1)</sup>

OLD PN: V23529-B\*\*\*\*-B\*\*\*-\*-7427

1) nach DIN 41652 T.2 und T.4  
 according to DIN 41652 T.2 AND T.4

THIS DRAWING IS A CONTROLLED DOCUMENT.		DWN GNANI_JADAV A E	07JAN10	<b>STE</b> TE Connectivity	
DIMENSIONS: mm		CHK K. MALCZYK	APVD K. MALCZYK		
TOLERANCES UNLESS OTHERWISE SPECIFIED:		PRODUCT SPEC		SIZE A2	
0 PLC ± - 1 PLC ± - 2 PLC ± - 3 PLC ± - 4 PLC ± - ANGLES ± -		APPLICATION SPEC		CAGE CODE 00779	
MATERIAL		WEIGHT		DRAWING NO C=1-1393480-7	
FINISH		CUSTOMER DRAWING		RESTRICTED TO	
		SCALE 2:1		SHEET 3 of 6	
				REV H1	

THIS DRAWING IS UNPUBLISHED. RELEASED FOR PUBLICATION  
 © COPYRIGHT - By - ALL RIGHTS RESERVED.

REVISIONS					
P	LTR	DESCRIPTION	DATE	DWN	APVD
-	-	SEE SHEET 1	-	-	-

mit Gewindebolzen: M3 V23529-B50x4-Bxxx-+  
 with threadlock 4-40 UNC V23529-B50x5-Bxxx-+

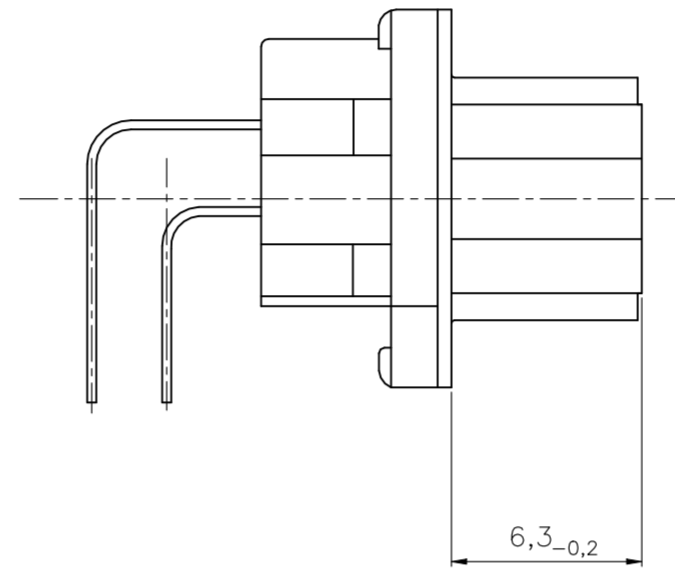
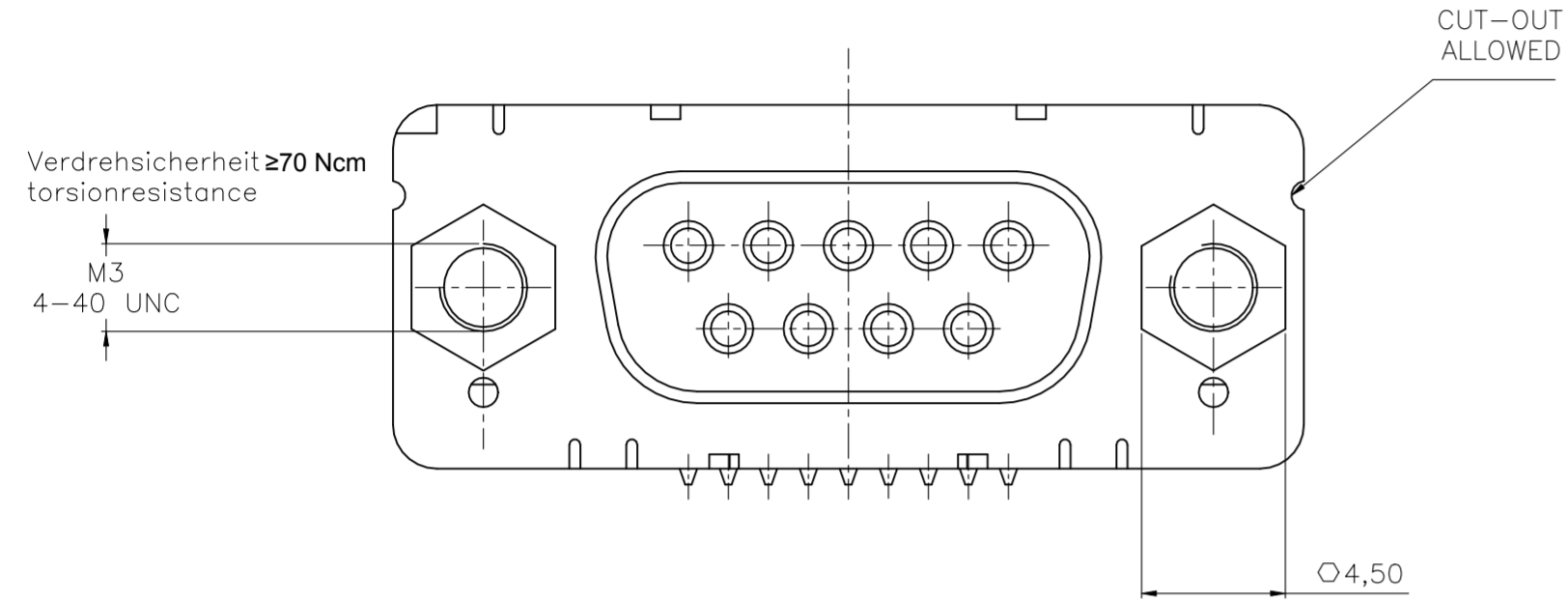

Leiterplattenbohrung  
 PCB hole pattern

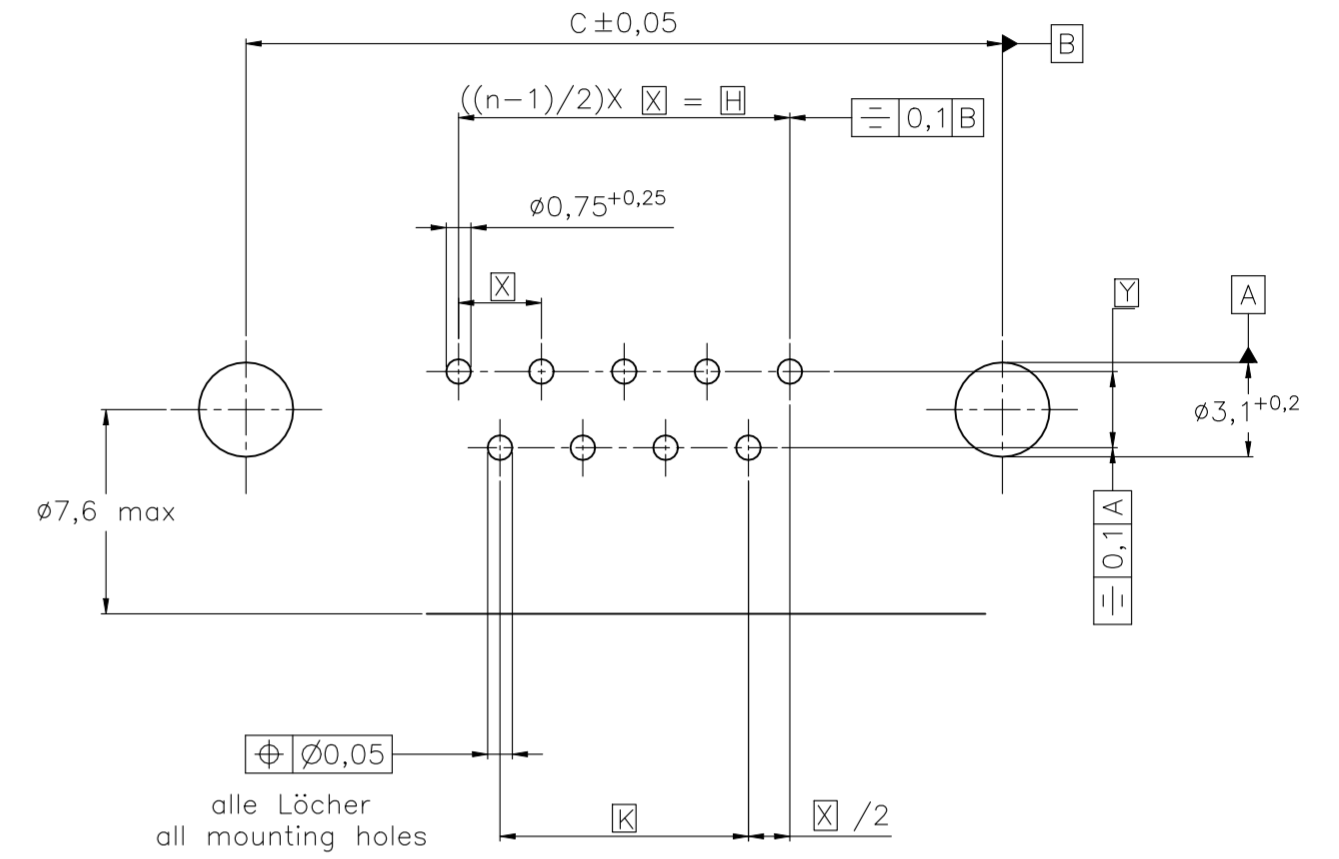

mit Gewinde : M3 V23529-B50x2-Bxxx-+  
 with thread 4-40 UNC V23529-B50x3-Bxxx-+

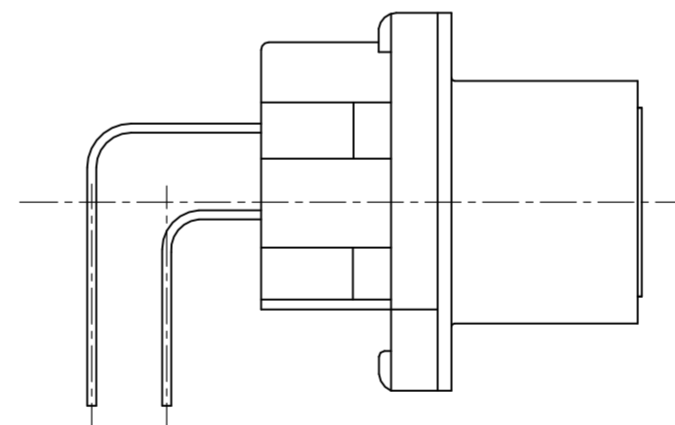
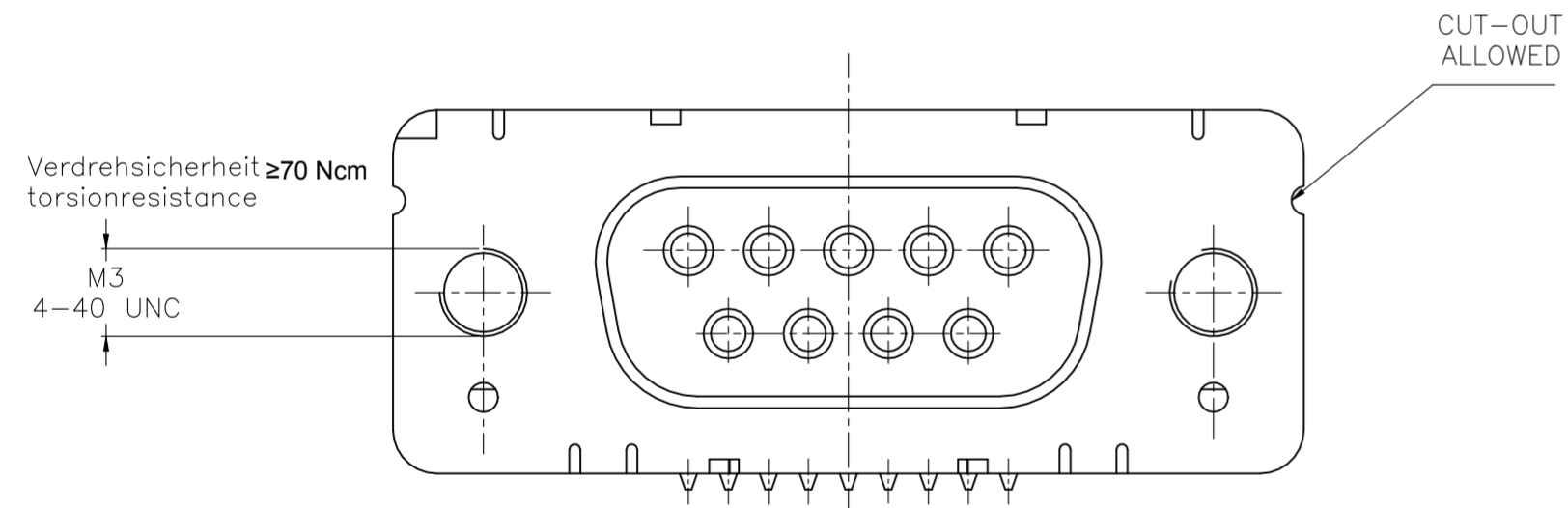

Mass Dimension	Polzahl n Number of contacts n			
	9	15	25	37
C	25	33,3	47,04	63,5
H	10,96	19,18	33,12	49,68
K	8,22	16,44	30,36	46,92
X	2,74	2,74	2,76	2,76
Y	2,54			

1) nach DIN 41652T.2 und T.4  
 according to DIN 41652 T.2 AND T.4

OLD PN: V23529-B\*\*\*\*-B\*\*\*-\*-7427

THIS DRAWING IS A CONTROLLED DOCUMENT.		DWN GNANI JADAV A E 07JAN10	TE Connectivity																			
DIMENSIONS: mm		CHK K. MALCZYK			NAME																	
TOLERANCES UNLESS OTHERWISE SPECIFIED:		APVD K. MALCZYK	Buchsenleiste <sup>1)</sup> Einbauhöhe 3,6 mm (Variante 1) Socketconnector-90° solderversion (Type1) <sup>1)</sup>																			
<table border="1"> <tr><td>0 PLC</td><td>±</td><td>-</td></tr> <tr><td>1 PLC</td><td>±</td><td>-</td></tr> <tr><td>2 PLC</td><td>±</td><td>-</td></tr> <tr><td>3 PLC</td><td>±</td><td>-</td></tr> <tr><td>4 PLC</td><td>±</td><td>-</td></tr> <tr><td>ANGLES</td><td>±</td><td>-</td></tr> </table>		0 PLC	±	-	1 PLC	±	-	2 PLC	±	-	3 PLC	±	-	4 PLC	±	-	ANGLES	±	-	PRODUCT SPEC	SIZE	RESTRICTED TO
0 PLC	±	-																				
1 PLC	±	-																				
2 PLC	±	-																				
3 PLC	±	-																				
4 PLC	±	-																				
ANGLES	±	-																				
MATERIAL		APPLICATION SPEC	CAGE CODE																			
FINISH		WEIGHT	DRAWING NO																			
		CUSTOMER DRAWING	A2 00779																			
		SCALE	2:1																			
		SHEET	4 of 6																			
		REV	H1																			

REVISIONS				
P	LTR	DESCRIPTION	DATE	APVD
-	-	SEE SHEET 1	-	-

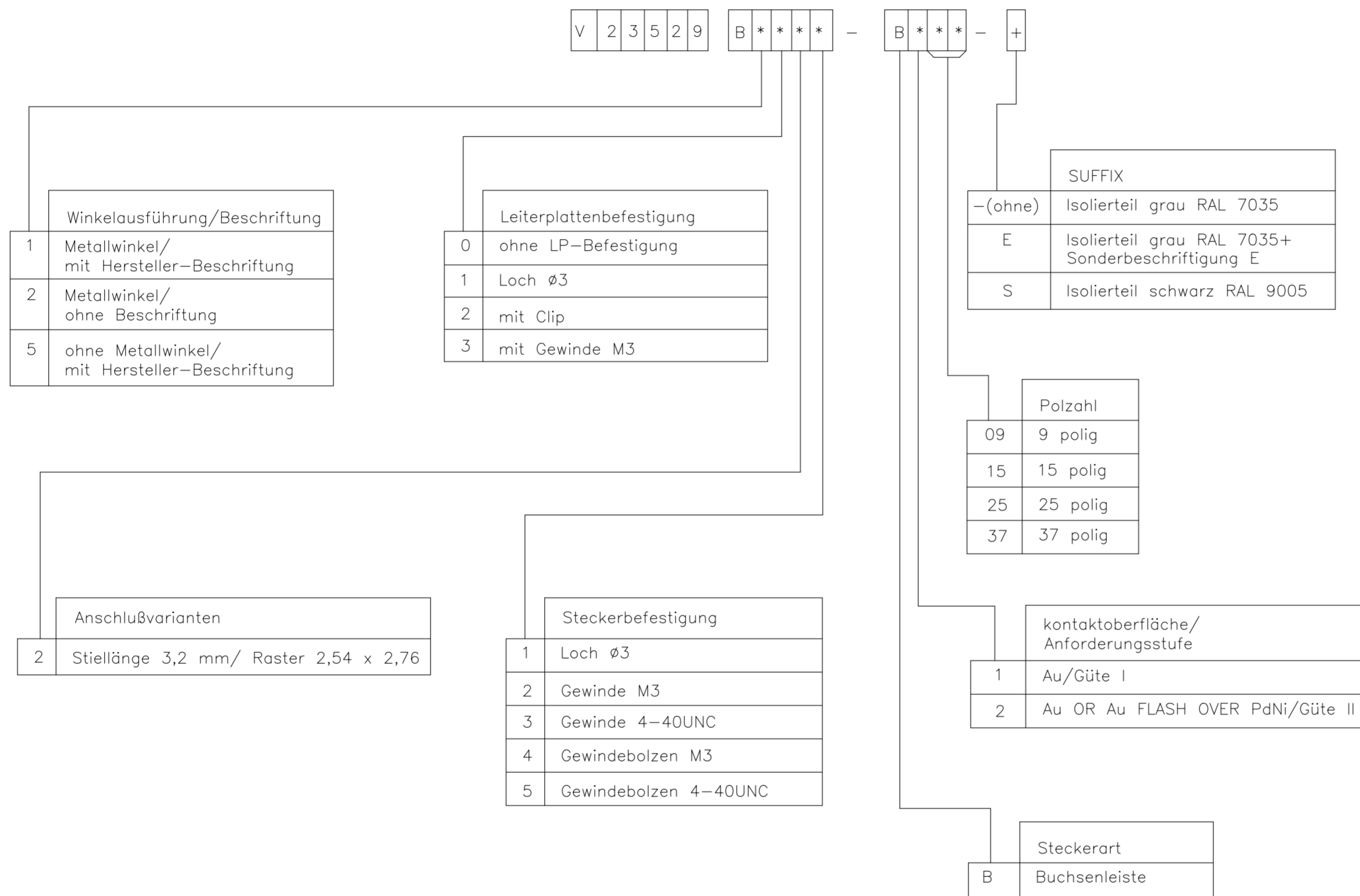

1) nach DIN 41652T.2 und T.4  
 according to DIN 41652 p.2 AND p.4

OLD PN: V23529-B\*\*\*\*\*-B\*\*\*-\*-7427

THIS DRAWING IS A CONTROLLED DOCUMENT.		DWN GNANI JADAV A E	07JAN10		
DIMENSIONS: mm		CHK K. MALCZYK	APVD K. MALCZYK	NAME Buchsenleiste	
		TOLERANCES UNLESS OTHERWISE SPECIFIED: 0 PLC ± - 1 PLC ± - 2 PLC ± - 3 PLC ± - 4 PLC ± - ANGLES ± -		Einbauhöhe 3,6 mm (Variante 1) <sup>1)</sup> Socketconnector-90° solderversion (Type1) <sup>1)</sup>	
MATERIAL	FINISH	WEIGHT	SCALE	SHEET	REV
-	-	-	A2	00779	C=1-1393480-7
CUSTOMER DRAWING			SCALE	SHEET	REV
			2:1	5 of 6	H1

THIS DRAWING IS UNPUBLISHED. RELEASED FOR PUBLICATION  
 © COPYRIGHT - By - ALL RIGHTS RESERVED.

REVISIONS				
P	LTR	DESCRIPTION	DATE	APVD
-	-	SEE SHEET 1	-	-

Active part numbers. Contact TE CONNECTIVITY for other configuration availability

Old Part Number	TE CONNECTIVITY Part Number
V23529-B1121-B209	1-1393480-7
V23529-B1121-B215	1-1393480-8
V23529-B1121-B225	1-1393480-9
V23529-B1121-B237	2-1393480-0
V23529-B1122-B209	2-1393480-8
V23529-B1122-B215	2-1393480-9
V23529-B1122-B225	3-1393480-0
V23529-B1122-B237	3-1392010-8
V23529-B1123-B109	3-1393480-4
V23529-B1123-B209	3-1393480-6
V23529-B1123-B215	3-1393480-7
V23529-B1123-B225	3-1393480-8
V23529-B1123-B237	3-1393480-9
V23529-B1125-B209	<del>4-1393480-7</del> OBSOLETE
V23529-B1125-B215	<del>4-1393480-8</del> OBSOLETE
V23529-B1125-B225	<del>4-1393480-9</del> OBSOLETE
V23529-B1125-B237	<del>5-1393480-0</del> OBSOLETE
V23529-B1221-B209	5-1393480-5
V23529-B1221-B215	5-1393480-6
V23529-B1221-B225	5-1393480-7
V23529-B1222-B109	6-1393480-4

Old Part Number	TE CONNECTIVITY Part Number
V23529-B1222-B115	6-1393480-5
V23529-B1222-B125	6-1393480-6
V23529-B1222-B209	6-1393480-7 OBSOLETE
V23529-B1222-B215	6-1393480-8 OBSOLETE
V23529-B1222-B225	6-1393480-9 OBSOLETE
V23529-B1222-B237	7-1393480-0 OBSOLETE
V23529-B1223-B109	7-1393480-8
V23529-B1223-B115	7-1393480-9
V23529-B1223-B125	8-1393480-0
V23529-B1223-B209	8-1393480-1
V23529-B1223-B215	8-1393480-2
V23529-B1223-B225	8-1393480-3
V23529-B1223-B237	8-1393480-4
V23529-B1224-B209	<del>9-1393480-0</del> OBSOLETE
V23529-B1224-B215	<del>9-1393480-1</del> OBSOLETE
V23529-B1224-B225	9-1393480-2
V23529-B1225-B209	9-1393480-9
V23529-B1225-B215	1393481-1
V23529-B1225-B225	1393481-2
V23529-B1225-B237	3-1392010-7
V23529-B2221-B209	1-1393481-1

1) nach DIN 41652 T.2 und T.4 according to DIN 41652 p.2 AND p.4

OLD PN: V23529-B\*\*\*\*-B\*\*\*-\*-7427

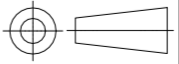
THIS DRAWING IS A CONTROLLED DOCUMENT.		DWN 07JAN10 GNANI JADAV A E	 TE Connectivity	
DIMENSIONS: mm		CHK K. MALCZYK		
		APVD K. MALCZYK	NAME Buchsenleiste <sup>1)</sup> Einbauhöhe 3,6 mm (Variante 1) Socketconnector-90° solderversion (Type1) <sup>1)</sup>	
TOLERANCES UNLESS OTHERWISE SPECIFIED:		PRODUCT SPEC	SIZE A2	CAGE CODE 00779
0 PLC ± - 1 PLC ± - 2 PLC ± - 3 PLC ± - 4 PLC ± - ANGLES ± -		APPLICATION SPEC	DRAWING NO C=1-1393480-7	RESTRICTED TO -
MATERIAL -		FINISH -	WEIGHT -	SCALE 2:1 SHEET 6 of 6 REV H1
CUSTOMER DRAWING				