

# SLIDE SWITCHES (1 mm PITCH)

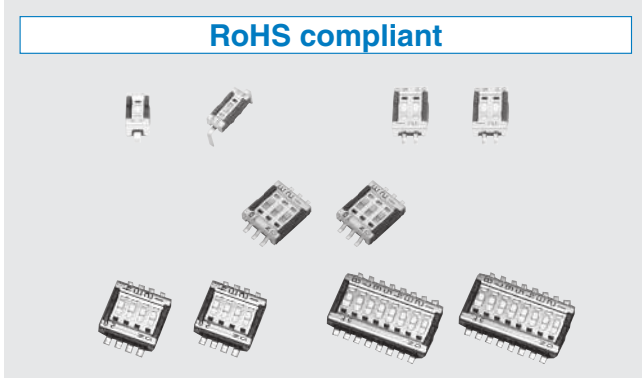

RoHS compliant



## FEATURES

- RoHS compliant
- Lowest profile design of 1.45 mm
- Fine pitch of 1 mm
- Easy motion with knob height of 0.2 mm

## INTERNAL STRUCTURE

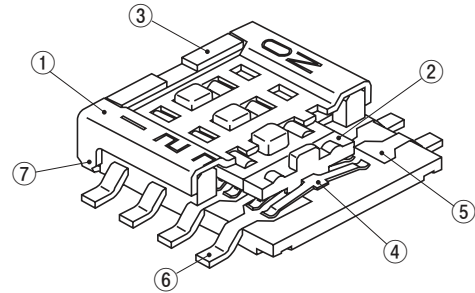

Part name	Material	Flammability
① Cover	Stainless steel, Gold-plated	—
② Slider	Polyamide	UL94V-0
③ Housing	Polyphenylenesulphide	
④ Slider contact	Stainless steel, Gold-plated	—
⑤ Fixed contact	Copper alloy, Gold-plated	
⑥ Terminal pin		
⑦ Earth terminal	Stainless steel, Gold-plated	—

## PART NUMBER DESIGNATION

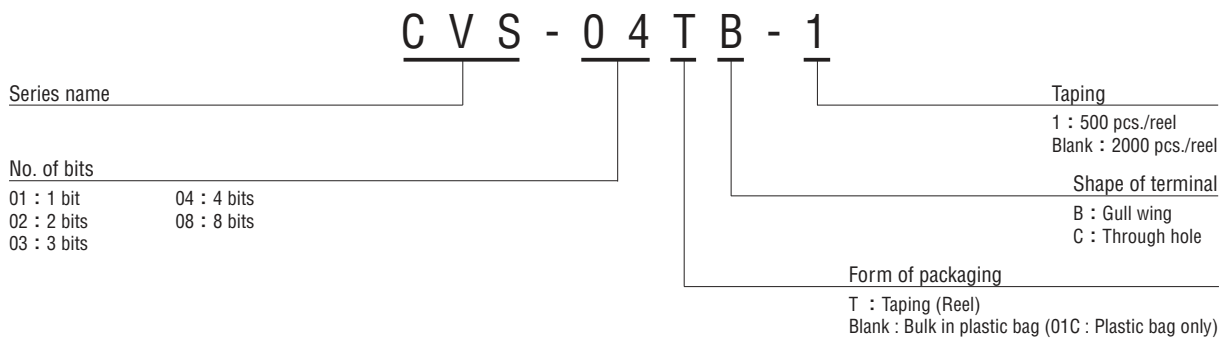

## LIST OF PART NUMBERS

No. of bits	Form of packaging	Shape of terminals	(Gull wing)	(Through hole)	Pieces in package
1	Taping		CVS-01TB-1	/	500 pcs./reel
	Taping		CVS-01TB	/	2000 pcs./reel
	Plastic bag		CVS-01B	CVS-01C	100 pcs./pack
2	Taping		CVS-02TB-1	/	500 pcs./reel
	Taping		CVS-02TB	/	2000 pcs./reel
	Plastic bag		CVS-02B	/	100 pcs./pack
3	Taping		CVS-03TB-1	/	500 pcs./reel
	Taping		CVS-03TB	/	2000 pcs./reel
	Plastic bag		CVS-03B	/	100 pcs./pack

No. of bits	Form of packaging	Shape of terminals	(Gull wing)	(Through hole)	Pieces in package
4	Taping		CVS-04TB-1	/	500 pcs./reel
	Taping		CVS-04TB	/	2000 pcs./reel
	Plastic bag		CVS-04B	/	100 pcs./pack
8	Taping		CVS-08TB-1	/	500 pcs./reel
	Taping		CVS-08TB	/	2000 pcs./reel
	Plastic bag		CVS-08B	/	100 pcs./pack

### STANDARD SPECIFICATIONS

Operating temp. range	- 40 ~ 85 °C
Storage temp. range	
Sealing	Non-washable
Net weight	Approx. 0.028g (CVS-01B) Approx. 0.031g (CVS-01C) Approx. 0.041g (CVS-02B) Approx. 0.054g (CVS-03B) Approx. 0.067g (CVS-04B) Approx. 0.13 g (CVS-08B)

### ELECTRICAL CHARACTERISTICS

Contact rating Non-switching Switching Minimum	DC50 V 100 mA DC6 V, 100 mA DC24 V, 25 mA DC20 mV 1 μA
Contact resistance	200 mΩ maximum
Insulation resistance	100 MΩ (DC100 V) minimum
Dielectric strength	AC250 V, 60 s

### MECHANICAL CHARACTERISTICS

Operating force	3 N {0.306 kgf} maximum
Stop strength	6 N {0.61 kgf}, 60 s
Solderability	245 ± 3 °C, 2 ~ 3 s
Soldering heat	Reflow : 255 °C (Peak temperature) (Please refer to the profile below)
	Manual soldering : 350 ± 10 °C, 3 ~ 4 s
Shear (Adhesion)	5 N {0.51 kgf} 10 s
Substrate bending	Width 90 mm, bend 3 mm, 5 s, 1 time
Pull-off strength	5 N {0.51 kgf} 10 s

### ENVIRONMENTAL CHARACTERISTICS

Vibration	(Amplitude) 1.5 mm or (Acceleration) 98 m/s <sup>2</sup> , 10-500 Hz, 3 directions for 10 cycles each
Shock	490 m/s <sup>2</sup> , 11 ms 6 directions for 3 times each
Load life	Continuous load 1000 cycles, DC6 ± 0.5 V, 100 ± 10 mA
Humidity	-10 ~ 65 °C, Relative humidity 0 ~ 96 %, 24 h for 10 cycles
High temp. exposure	85 °C, 96 h
Low temp. exposure	-40 °C, 96 h
Thermal shock	-40 (0.5 h) ~ 85 °C (0.5 h), 5 cycles

{ } : Reference only

### Reflow profile for soldering heat evaluation

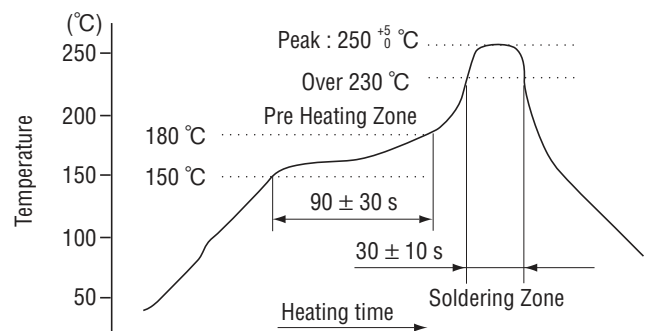

Reflow : two times maximum

**OUTLINE DIMENSIONS**

Unless otherwise specified, tolerance : ± 0.3 (Unit : mm)

● CVS-01B

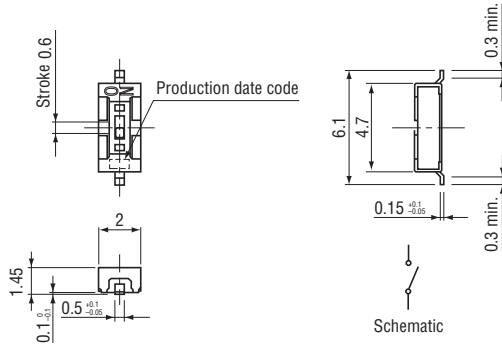

● CVS-01C

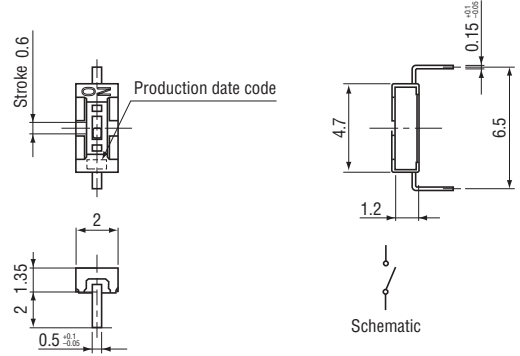

● CVS-□□B

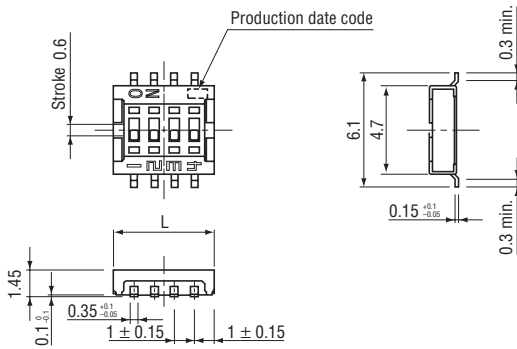

Part number	Schematic	No. of bits.	L dimension
CVS-02		2	3
CVS-03		3	4
CVS-04		4	5
CVS-08		8	9

**RECOMMENDED P.C.B. PAD OUTLINE DIMENSIONS**

(Unit : mm)

● CVS-01B

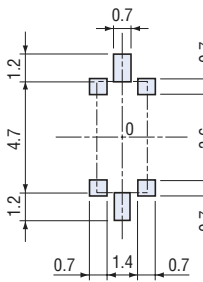

● CVS-02B

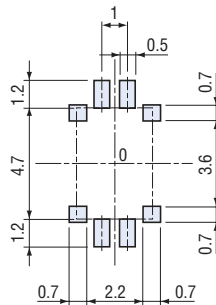

● CVS-03B

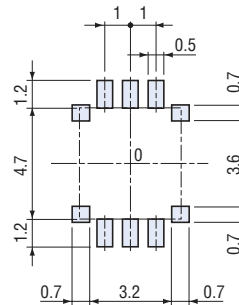

● CVS-04B

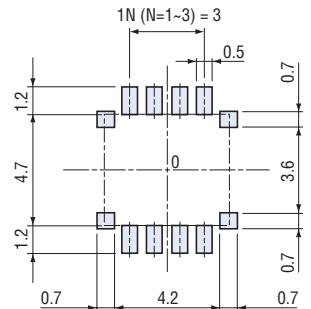

● CVS-08B

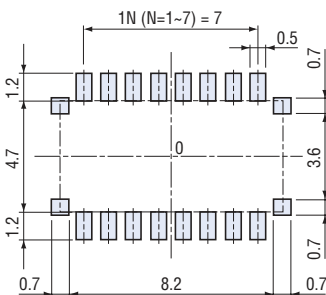

**SIZE OF P.C.B. PROCESSING** (Unit : mm)

● CVS-01C

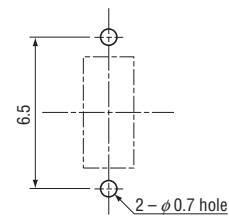

# CVS

## SLIDE SWITCHES (1 mm PITCH)

### PACKAGING SPECIFICATIONS

#### <Taping packaging specifications>

● Taping version is packaged in 2000 pcs. or 500 pcs. per reel. Orders will be accepted for units of 2000 pcs., i.e., 2000, 4000, 6000 pcs., etc. or for units of 500 pcs., i.e., 500, 1000, 1500 pcs., etc.

● Taping version is boxed with two reels.  
Maximum number of consecutive missing pieces = 2  
Leader length and reel dimension are shown in the diagrams below:

#### ● Embossed tape dimensions

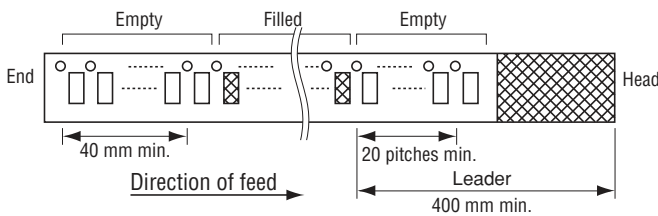

#### ● Reel dimensions (Conforms to JIS C 0806-3) (In accordance with EIAJ ET-7200A)

(Unit: mm)

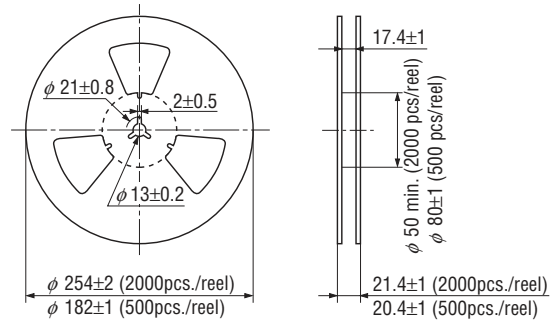

#### ● 1 bit

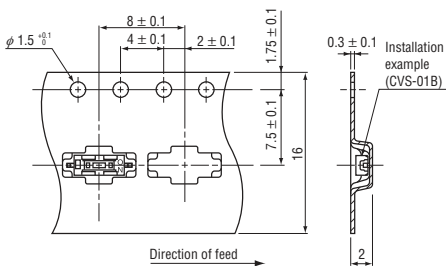

#### ● 2 bits

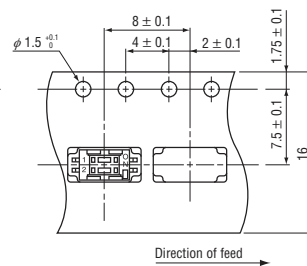

#### ● 3 bits

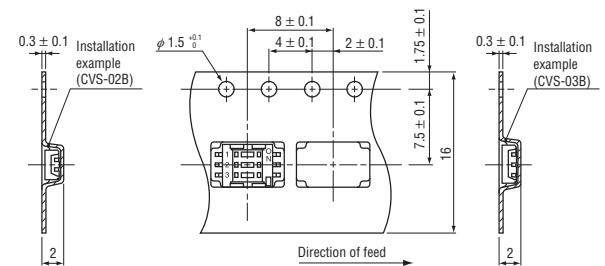

#### ● 4 bits

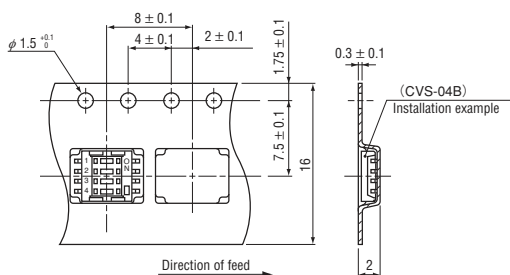

#### ● 8 bits

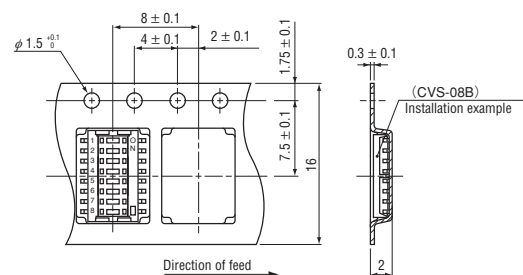

#### <Bulk pack specifications>

● The smallest unit of bulk pack in a plastic bag is 10 pcs. per pack.  
Orders will be accepted for unit of minimum 10 pcs., i.e., 10, 20, 30 pcs., etc.

● Boxing of bulk in a plastic bag is performed with 100 pcs. (standard 500 pcs.) per box.