

REV.	DATE	ECR NO.	DESCRIPTION
NC	09/08/11	XXXXXX	INITIAL RELEASE

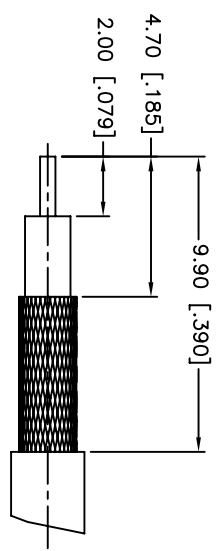

RECOMMENDED
CABLE STRIPPING DIM'S

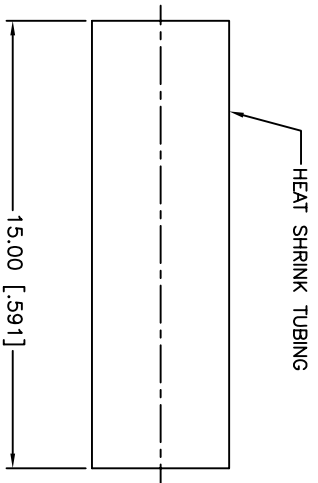
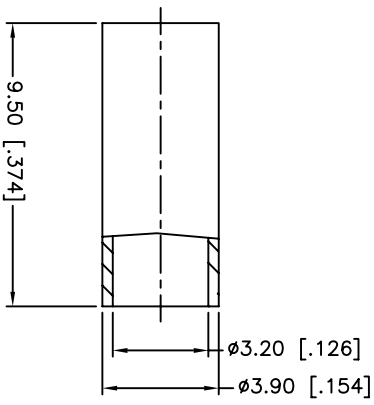
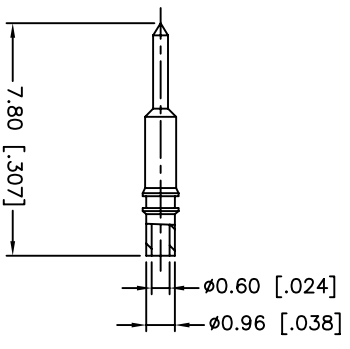
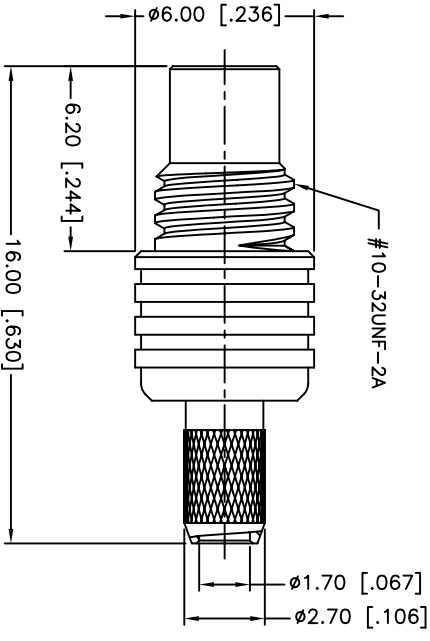
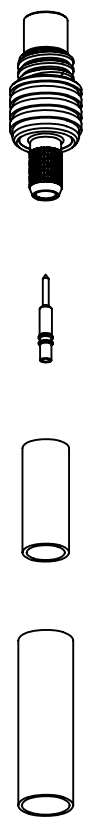

1. IMPEDANCE: 50 OHM
 2. FREQUENCY RANGE: DC 0-10 GHz
 3. DIELECTRIC WITHSTANDING VOLTAGE: 1000 VRMS, MIN.
 4. CRIMPED FERRULE
 5. HEX CRIMP SIZE .128"
- SO. CRIMP SIZE 0.7(mm)

QTY	FINISH	MATERIAL	DESCRIPTION
1	GOLD	BRASS	BODY
1	NATURAL	PTE	INSULATOR
1	GOLD	BRASS	BARREL
1	GOLD	BRASS	CONTACT PIN
1	GOLD	BRASS	FERRULE
1	BLACK	BLACK	HEAT SHRINK TUBING

UNLESS OTHERWISE SPECIFIED, DIMENSIONS ARE IN INCHES AND FOR CUSTOMER REFERENCE ONLY.
TOLERANCES FOR MILLIMETERS ARE:
UNLESS OTHERWISE SPECIFIED
0.5 - 8mm ± 0.20mm
8 - 30mm ± 0.40mm
30 - 120mm ± 0.50mm
TOLERANCES FOR INCHES ARE:
UNLESS OTHERWISE SPECIFIED
.020 - .315 = ± 0.007"
.315 - 1.180 = ± 0.015"
1.180 - 4.724 = ± 0.020"
DO NOT SCALE DRAWING

APPROVALS	DATE
M.ZHANG	09/08/11
CHECKED	
ISSUED	
SHEET 1 OF 1	

Amphenol Connex

SMC CRIMP JACK
(FOR RG-174/U, 188A/U, 316/U CABLE)

PART NO. 152103

DWG. NO. 152103.DWG

REV. NC SIZE A SCALE NA