

**RIGHT ANGLE PLUG CRIMP TYPE
CABLE 2.6/75 S**

R213.182.007
SERIES MCX 75

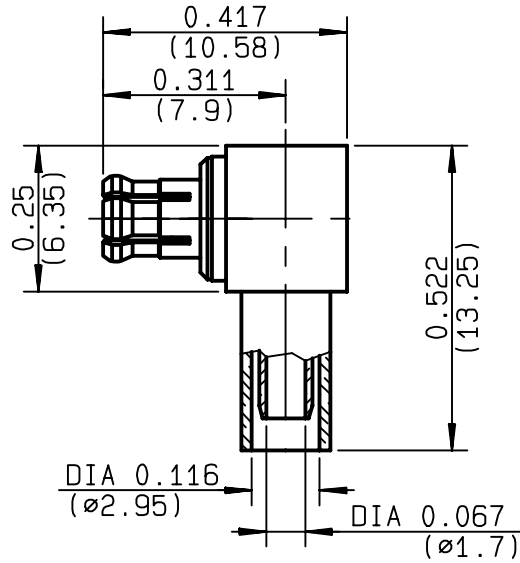

NOMINAL IMPEDANCE	75 Ω	CABLES : RG 179
FREQUENCY RANGE	0-6 GHz	RG 187
TEMPERATURE RATING	-55/+155 °C	
V.S.W.R	1.05 + .02 x F(GHz)Maxi	
RF INSERTION LOSS	0.08 √F(GHz) dB Maxi	
VOLTAGE RATING	335 Veff Maxi	
DIELECTRIC WITHSTANDING VOLTAGE	750 Veff Mini	
INSULATION RESISTANCE	1000 MΩMini	OTHERS CHARACTERISTICS
HERMETIC SEAL	NA Atm.cm ³ /s	CABLE RETENTION 53 N Mini
LEAKAGE (pressurized only)	NA	CENTER CONTACT RETENTION
MECHANICAL DURABILITY	500 Cycles	Axial force - mating end 10 N Mini
WEIGHT	1.85 gr	Axial force - opposite end 10 N Mini
SPECIFICATION		Torque NA cm.N Mini
		RECOMMENDED TORQUES
		Mating NA cm.N
		Panel nut NA cm.N
		Clamp nut NA cm.N

CONNECTOR PARTS	MATERIALS	FINISH	(all values are given) in micrometers
BODY	BRASS	BBR 2	
OUTER CONTACT	BERYLLIUM COPPER	BBR 2	
CENTER CONTACT	BRASS	GOLD 1.3 OVER NICKEL 2	
INSULATOR	PTFE	-	
GASKET	-	-	
OTHERS PIECES	BRASS	BBR 2	

ISSUE	CREATION DATE	FILE PART-NUMBER
9916A02	23/08/1996	96-1200-002



AGRIODOS

The information given here is subject to change without notice.
Design changes may be in order to improve the product .

Connect to the future



R213.182.007

ISSUE 9916A02 SERIES MCX 75

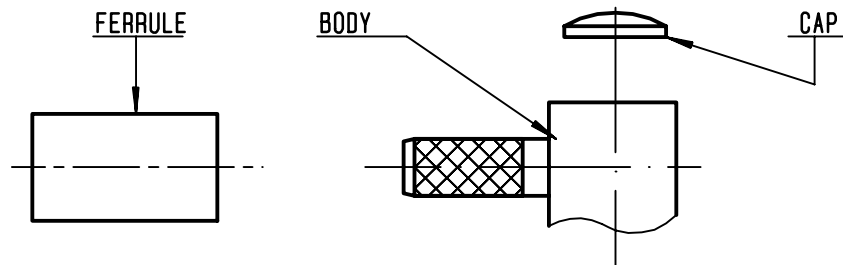

①

Slide onto the cable the ferrule .
Strip the cable .
Tin cable inner conductor
-

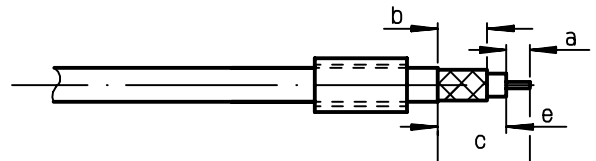

Stripping	a	b	c	d	e
inch	0.067	0.217	0.382	0	0.315
mm	1.7	5.5	9.7		8

②

Fan the braid .
Push connector body under the braid .
Slide the ferrule on the braid
(in direction F)
-
-

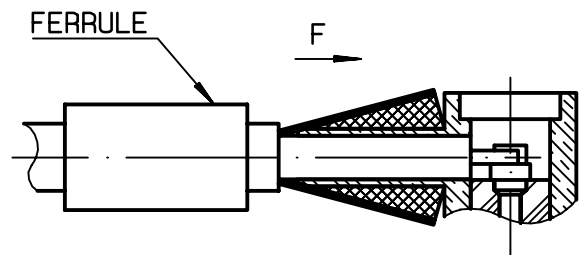

③

Crimp the ferrule with crimping tool
R282.211.000 (Hex. : 0.127) (3.25)
Solder inner conductor .

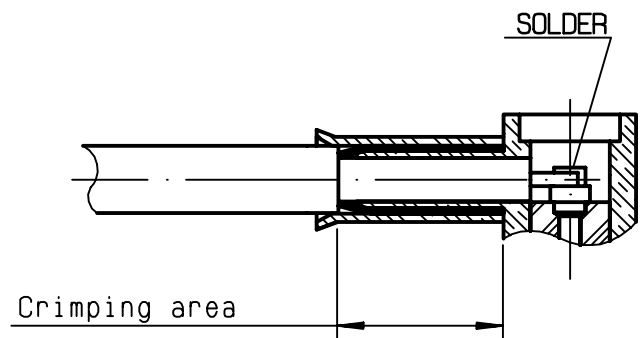

④

Place the cap .
Press cap flush or slightly below surface
of body assembly .
-
-

