



# STEVAL-ILL029V1

Front panel demonstration board  
based on the STLEDD325 and STM8S

Data brief

## Features

- 4-digit, 7-segment (with decimal point) LED display
- 8 discrete LEDs
- 8 front panel keys for control of channel, brightness and board functions
- Bi-color power/standby LED
- Interrupt indicator LED (blinks with interrupt)
- Potentiometer for adjusting display brightness
- Demo mode available
- Easily extendable to multi-format remote control operation (only RC5 supported currently)
- Embedded in-circuit programming using SWIM interface for the STM8S
- RoHS compliant

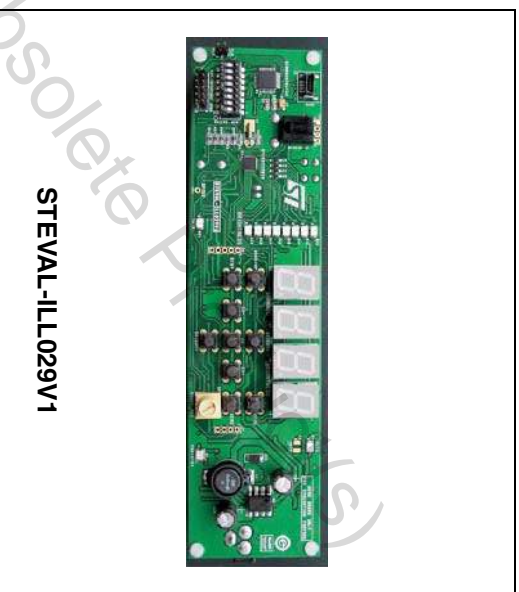

## Description

The STEVAL-ILL029V1 front panel demonstration board provides an evaluation platform for the STLEDD325 advanced LED controller driver, and the STM8S 8-bit microcontroller as I<sup>2</sup>C master.

The features of the STLEDD325 that this front panel application demonstrates include key scanning, RTC, IR decoding, and standby management. These features are required to address the market segment for DVD players, DVD recorders, set-top boxes, washing machines and many others, while keeping system costs as low as possible.

The system can be operated using the front panel keys mounted on the board, or by remote control.

System I/Os are handled completely by the STLEDD325, with minimal load on the host processor.



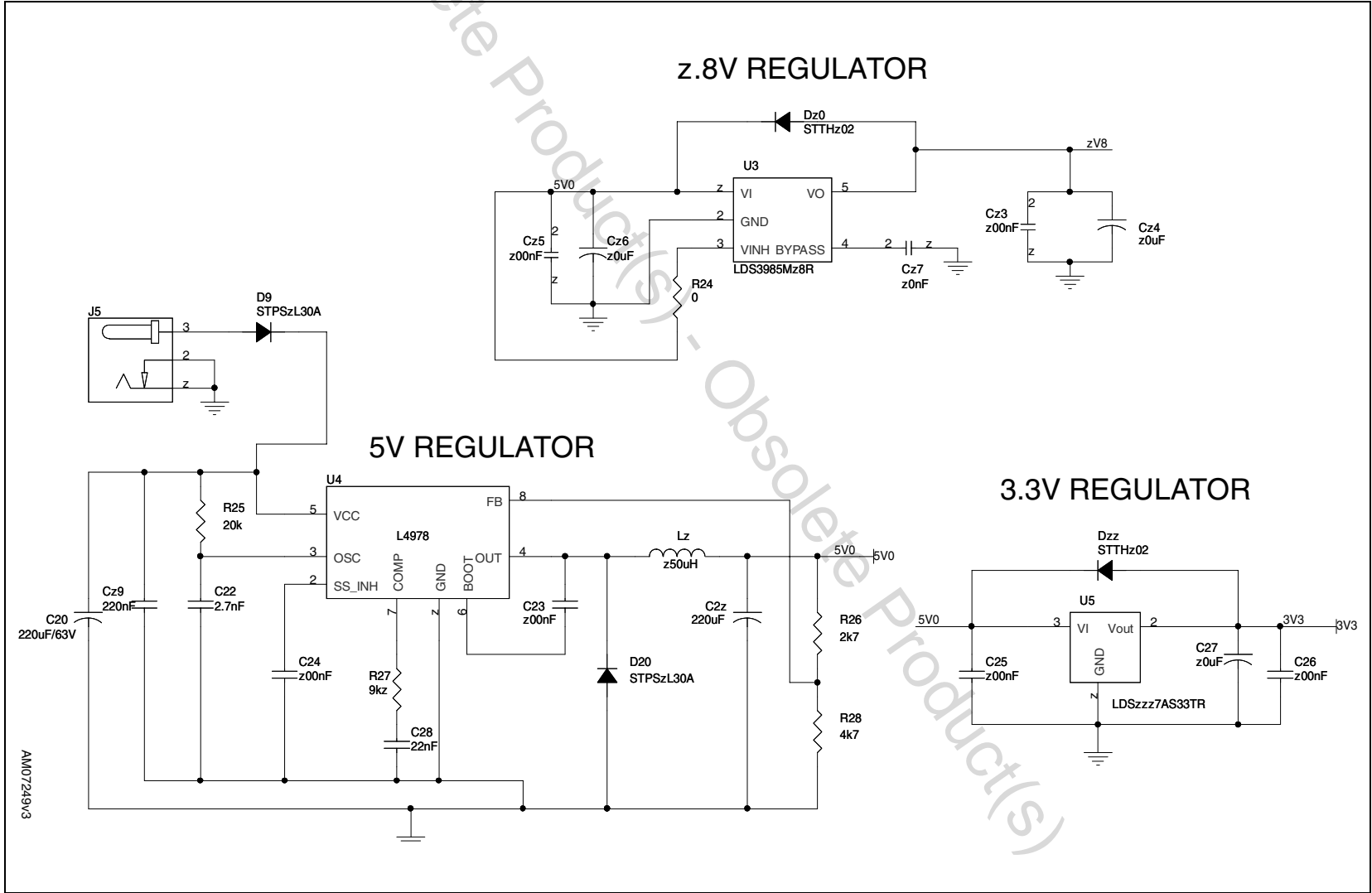
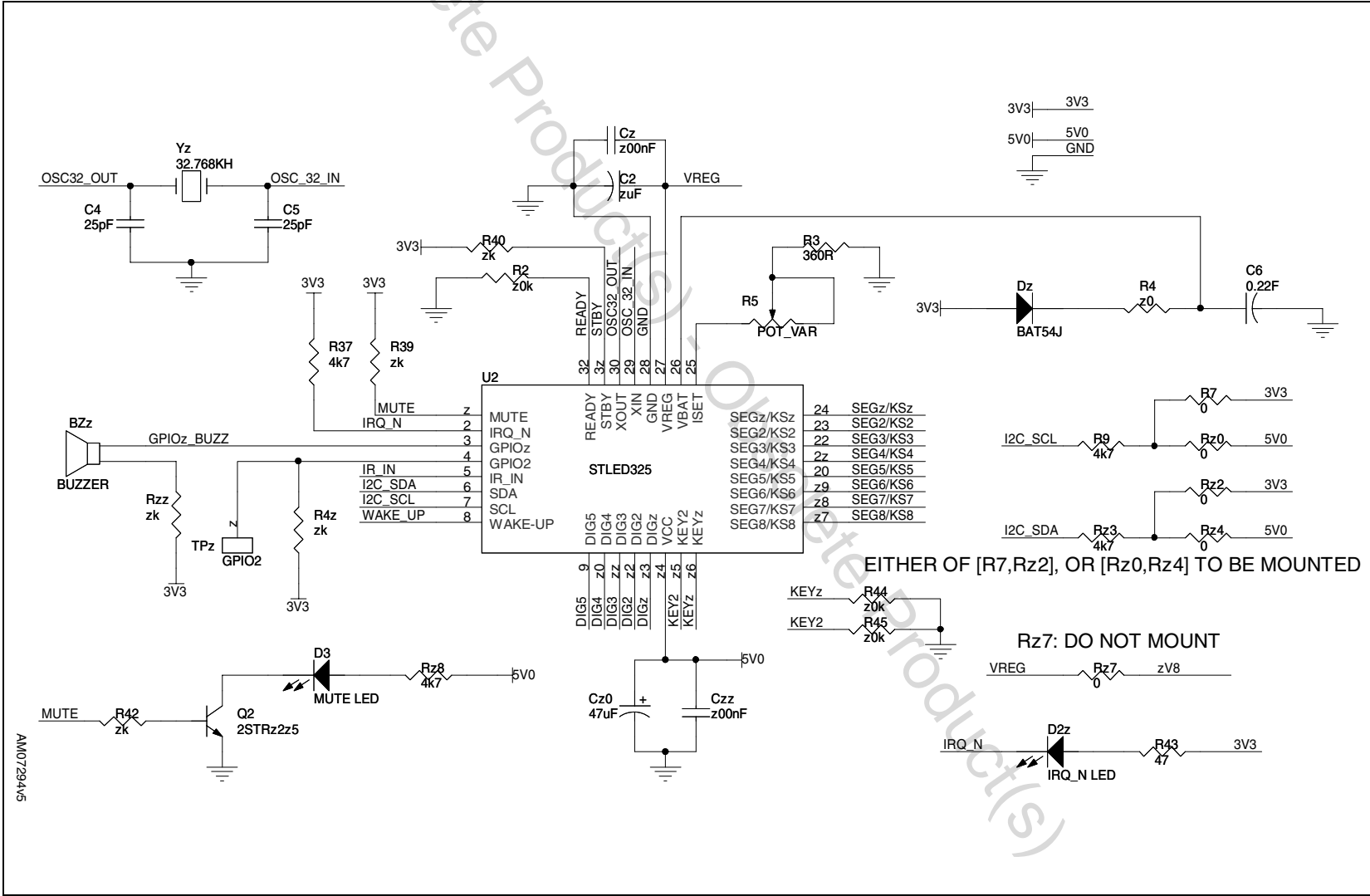

Figure 2. STEVAL-ILL029V1: power supply

Figure 3. STEVAL-ILL029V: STLED325



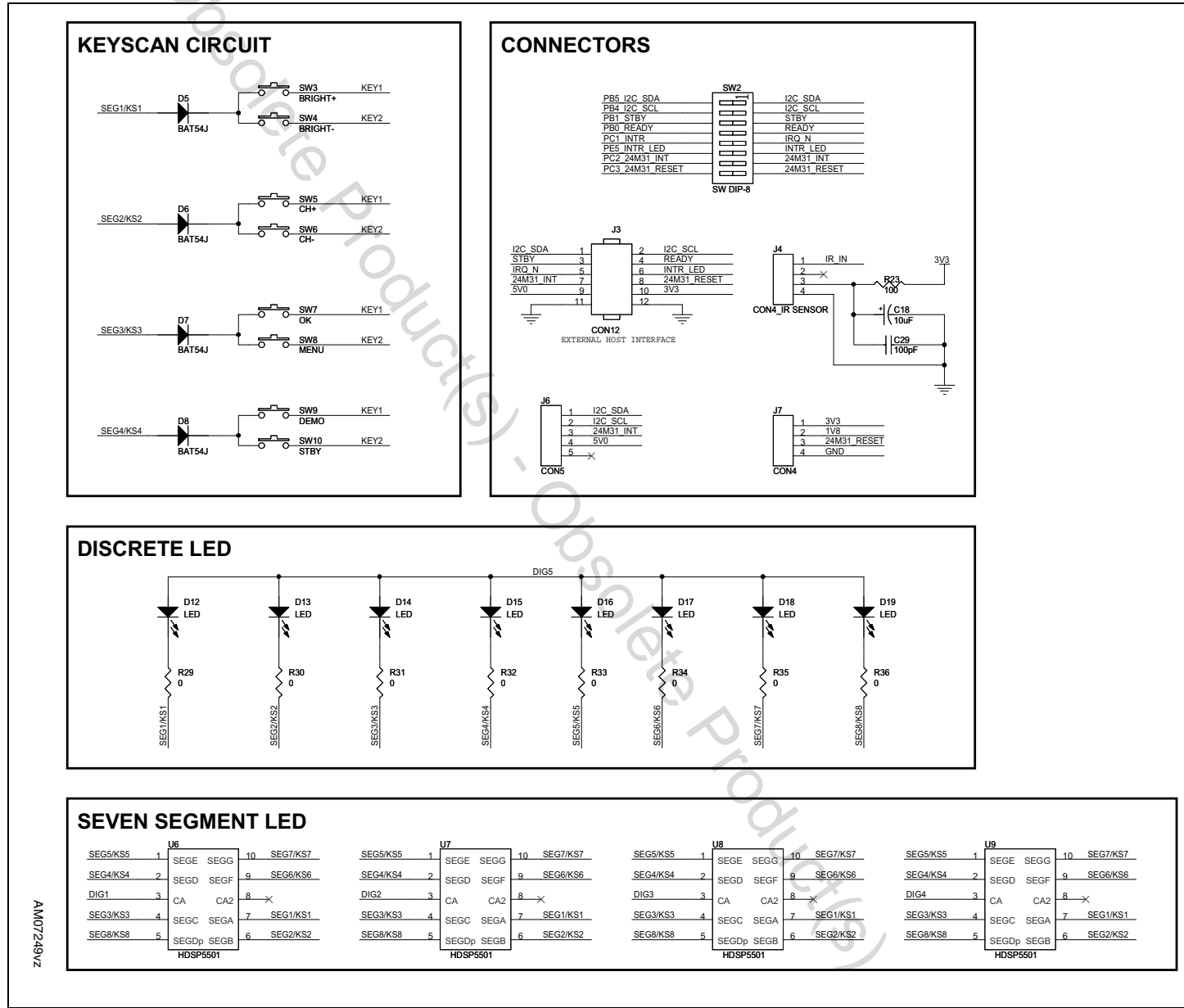

Figure 4. STEVAL-ILL029V1: other blocks

## 2 Revision history

Table 1. Document revision history

Date	Revision	Changes
23-Jun-2010	1	Initial release.

Obsolete Product(s) - Obsolete Product(s)

**Please Read Carefully:**

Information in this document is provided solely in connection with ST products. STMicroelectronics NV and its subsidiaries ("ST") reserve the right to make changes, corrections, modifications or improvements, to this document, and the products and services described herein at any time, without notice.

All ST products are sold pursuant to ST's terms and conditions of sale.

Purchasers are solely responsible for the choice, selection and use of the ST products and services described herein, and ST assumes no liability whatsoever relating to the choice, selection or use of the ST products and services described herein.

No license, express or implied, by estoppel or otherwise, to any intellectual property rights is granted under this document. If any part of this document refers to any third party products or services it shall not be deemed a license grant by ST for the use of such third party products or services, or any intellectual property contained therein or considered as a warranty covering the use in any manner whatsoever of such third party products or services or any intellectual property contained therein.

**UNLESS OTHERWISE SET FORTH IN ST'S TERMS AND CONDITIONS OF SALE ST DISCLAIMS ANY EXPRESS OR IMPLIED WARRANTY WITH RESPECT TO THE USE AND/OR SALE OF ST PRODUCTS INCLUDING WITHOUT LIMITATION IMPLIED WARRANTIES OF MERCHANTABILITY, FITNESS FOR A PARTICULAR PURPOSE (AND THEIR EQUIVALENTS UNDER THE LAWS OF ANY JURISDICTION), OR INFRINGEMENT OF ANY PATENT, COPYRIGHT OR OTHER INTELLECTUAL PROPERTY RIGHT.**

**UNLESS EXPRESSLY APPROVED IN WRITING BY AN AUTHORIZED ST REPRESENTATIVE, ST PRODUCTS ARE NOT RECOMMENDED, AUTHORIZED OR WARRANTED FOR USE IN MILITARY, AIR CRAFT, SPACE, LIFE SAVING, OR LIFE SUSTAINING APPLICATIONS, NOR IN PRODUCTS OR SYSTEMS WHERE FAILURE OR MALFUNCTION MAY RESULT IN PERSONAL INJURY, DEATH, OR SEVERE PROPERTY OR ENVIRONMENTAL DAMAGE. ST PRODUCTS WHICH ARE NOT SPECIFIED AS "AUTOMOTIVE GRADE" MAY ONLY BE USED IN AUTOMOTIVE APPLICATIONS AT USER'S OWN RISK.**

Resale of ST products with provisions different from the statements and/or technical features set forth in this document shall immediately void any warranty granted by ST for the ST product or service described herein and shall not create or extend in any manner whatsoever, any liability of ST.

ST and the ST logo are trademarks or registered trademarks of ST in various countries.

Information in this document supersedes and replaces all information previously supplied.

The ST logo is a registered trademark of STMicroelectronics. All other names are the property of their respective owners.

© 2010 STMicroelectronics - All rights reserved

STMicroelectronics group of companies

Australia - Belgium - Brazil - Canada - China - Czech Republic - Finland - France - Germany - Hong Kong - India - Israel - Italy - Japan - Malaysia - Malta - Morocco - Philippines - Singapore - Spain - Sweden - Switzerland - United Kingdom - United States of America

[www.st.com](http://www.st.com)

