

# BGT24ATR12

Silicon Germanium 24 GHz Transceiver MMIC

## Data Sheet

Revision 3.1, 2014-07-15

**Edition 2014-07-15**

**Published by  
Infineon Technologies AG  
81726 Munich, Germany**

**© 2014 Infineon Technologies AG  
All Rights Reserved.**

### **Legal Disclaimer**

The information given in this document shall in no event be regarded as a guarantee of conditions or characteristics. With respect to any examples or hints given herein, any typical values stated herein and/or any information regarding the application of the device, Infineon Technologies hereby disclaims any and all warranties and liabilities of any kind, including without limitation, warranties of non-infringement of intellectual property rights of any third party.

### **Information**

For further information on technology, delivery terms and conditions and prices, please contact the nearest Infineon Technologies Office ([www.infineon.com](http://www.infineon.com)).

### **Warnings**

Due to technical requirements, components may contain dangerous substances. For information on the types in question, please contact the nearest Infineon Technologies Office.

Infineon Technologies components may be used in life-support devices or systems only with the express written approval of Infineon Technologies, if a failure of such components can reasonably be expected to cause the failure of that life-support device or system or to affect the safety or effectiveness of that device or system. Life support devices or systems are intended to be implanted in the human body or to support and/or maintain and sustain and/or protect human life. If they fail, it is reasonable to assume that the health of the user or other persons may be endangered.

**BGT24ATR12 Silicon Germanium 24 GHz Transceiver MMIC**

**Revision History: 2014-07-15, Revision 3.1**

**Previous Revision: 2013-09-10, Revision 3.0**

Page	Subjects (major changes since last revision)
25	update recommended footprint drawing (change of ground plains)

**Trademarks of Infineon Technologies AG**

AURIX™, C166™, CanPAK™, CIPOS™, CIPURSE™, EconoPACK™, CoolMOS™, CoolSET™, CORECONTROL™, CROSSAVE™, DAVE™, EasyPIM™, EconoBRIDGE™, EconoDUAL™, EconoPIM™, EiceDRIVER™, eupec™, FCOS™, HITFET™, HybridPACK™, I<sup>2</sup>RF™, ISOFACE™, IsoPACK™, MIPAQ™, ModSTACK™, my-d™, NovalithIC™, OptiMOS™, ORIGA™, PRIMARION™, PrimePACK™, PrimeSTACK™, PRO-SIL™, PROFET™, RASIC™, ReverSave™, SatRIC™, SIEGET™, SINDRION™, SIPMOS™, SmartLEWIS™, SOLID FLASH™, TEMPFET™, thinQ!™, TRENCHSTOP™, TriCore™.

**Other Trademarks**

Advance Design System™ (ADS) of Agilent Technologies, AMBA™, ARM™, MULTI-ICET™, KEIL™, PRIMECELL™, REALVIEW™, THUMB™, μVision™ of ARM Limited, UK. AUTOSAR™ is licensed by AUTOSAR development partnership. Bluetooth™ of Bluetooth SIG Inc. CAT-ig™ of DECT Forum. COLOSSUS™, FirstGPS™ of Trimble Navigation Ltd. EMV™ of EMVCo, LLC (Visa Holdings Inc.). EPCOS™ of Epcos AG. FLEXGO™ of Microsoft Corporation. FlexRay™ is licensed by FlexRay Consortium. HYPERTERMINAL™ of Hilgraeve Incorporated. IEC™ of Commission Electrotechnique Internationale. IrDA™ of Infrared Data Association Corporation. ISO™ of INTERNATIONAL ORGANIZATION FOR STANDARDIZATION. MATLAB™ of MathWorks, Inc. MAXIM™ of Maxim Integrated Products, Inc. MICROTEC™, NUCLEUS™ of Mentor Graphics Corporation. Mifare™ of NXP. MIPI™ of MIPI Alliance, Inc. MIPS™ of MIPS Technologies, Inc., USA. muRata™ of MURATA MANUFACTURING CO., MICROWAVE OFFICE™ (MWO) of Applied Wave Research Inc., OmniVision™ of OmniVision Technologies, Inc. Openwave™ Openwave Systems Inc. RED HAT™ Red Hat, Inc. RFMD™ RF Micro Devices, Inc. SIRIUS™ of Sirius Satellite Radio Inc. SOLARIS™ of Sun Microsystems, Inc. SPANSION™ of Spansion LLC Ltd. Symbian™ of Symbian Software Limited. TAIYO YUDEN™ of Taiyo Yuden Co. TEAKLITE™ of CEVA, Inc. TEKTRONIX™ of Tektronix Inc. TOKO™ of TOKO KABUSHIKI KAISHA TA. UNIX™ of X/Open Company Limited. VERILOG™, PALLADIUM™ of Cadence Design Systems, Inc. VLYNQ™ of Texas Instruments Incorporated. VXWORKS™, WIND RIVER™ of WIND RIVER SYSTEMS, INC. ZETEX™ of Diodes Zetex Limited.

Last Trademarks Update 2011-02-24

## Table of Contents

	<b>Table of Contents</b> .....	4
	<b>List of Figures</b> .....	5
	<b>List of Tables</b> .....	6
<b>1</b>	<b>Features</b> .....	7
<b>2</b>	<b>Electrical Characteristics</b> .....	9
2.1	Absolute Maximum Ratings .....	9
2.2	Thermal Resistance .....	10
2.3	ESD Integrity .....	10
2.4	Measured RF Characteristics .....	11
2.4.1	Power Supply .....	11
2.4.2	TX Section .....	11
2.4.3	RX Section .....	14
2.5	Temperature Sensor .....	15
2.6	Power Detector .....	15
<b>3</b>	<b>Application Circuit and Block Diagram</b> .....	16
3.1	Application Circuit Schematic .....	16
3.2	Pin Description .....	18
3.3	SPI .....	19
3.4	Application Board .....	22
3.5	Equivalent Circuit Diagram of MMIC Interfaces .....	24
<b>4</b>	<b>Physical Characteristics</b> .....	25
4.1	Package Footprint .....	25
4.2	Reflow Profile .....	26
4.3	Package Dimensions .....	27

## List of Figures

Figure 1	BGT24ATR12 Block Diagram . . . . .	8
Figure 2	VCO Tuning Window . . . . .	12
Figure 3	Application Circuit with Chip Outline (Top View) . . . . .	16
Figure 4	Timing Diagram of the SPI . . . . .	20
Figure 5	Cross-Section View of Application Board . . . . .	22
Figure 6	Detail of Compensation Structure (valid for appl. board mat. Ro4350B, 0.254mm acc. to Fig. 5) . . . . .	22
Figure 7	Application Board Layout . . . . .	23
Figure 8	Equivalent Circuit Diagram of MMIC Interfaces . . . . .	24
Figure 9	Recommended Footprint and Stencil Layout for the VQFN32-9 Package . . . . .	25
Figure 10	Reflow Profile for BGT24ATR12 (VQFN32-9) . . . . .	26
Figure 11	Package Outline (Top, Side and Bottom View) . . . . .	27
Figure 12	Marking Layout VQFN32-9 . . . . .	27
Figure 13	Tape of VQFN32-9 . . . . .	28

## List of Tables

Table 1	Absolute Maximum Ratings .....	9
Table 2	Thermal Resistance .....	10
Table 3	ESD Integrity .....	10
Table 4	Typical Characteristics $T_A = -40 \dots 125 \text{ }^\circ\text{C}$ , SPI-Bit 4 = low .....	11
Table 5	Typical Characteristics $T_A = -40 \dots 125 \text{ }^\circ\text{C}$ , $f = 24.0 \dots 24.25 \text{ GHz}$ , SPI-Bit 4 = low .....	11
Table 6	Typical Characteristics $T_A = -40 \dots 125 \text{ }^\circ\text{C}$ , $f = 24.0 \dots 24.25 \text{ GHz}$ , SPI-Bit 4 = low .....	12
Table 7	Typical Characteristics $T_A = -40 \dots 125 \text{ }^\circ\text{C}$ , $f = 24.0 \dots 24.25 \text{ GHz}$ , SPI-Bit 4 = low .....	14
Table 8	Typical Characteristics Temperature Sensor $T_A = -40 \dots 125 \text{ }^\circ\text{C}$ .....	15
Table 9	Typical Characteristics Power Detector $T_A = -40 \dots 125 \text{ }^\circ\text{C}$ , $V_{CC} = 3.3 \text{ V}$ .....	15
Table 10	Bill of Materials .....	17
Table 11	Pin Definition and Function .....	18
Table 12	SPI Block Data Bit Description .....	19
Table 13	SPI Timing and Logic Levels .....	20
Table 14	Truth Table AMUX .....	20

## 1 Features

- 24 GHz ISM band transceiver MMIC with one transmitter and two receiver units
- Qualified according AEC-Q100
- Fully integrated low phase noise VCO
- Switchable prescaler with 1.5 GHz and 23 kHz output
- On chip power and temperature sensors
- Gilbert based homodyne quadrature receiver
- Single ended RF input terminals
- Low noise figure  $NF_{SSB}$ : 12 dB
- High conversion gain: 26 dB
- High 1 dB input compression point: -12 dBm
- Single supply voltage 3.3 V
- Low power consumption 690 mW
- 200 GHz bipolar SiGe:C technology b7hf200
- Fully ESD protected device
- VQFN-32-9 leadless plastic package incl. LTI feature
- Pb-free (RoHS compliant) package



### Description

The BGT24ATR12 is a Silicon Germanium MMIC for signal generation and reception, operating in the 24 GHz ISM band from 24.00 to 24.25 GHz. It is based on a 24 GHz fundamental voltage controlled oscillator. A switchable frequency prescaler is included with output frequencies of 1.5 GHz and 23 kHz. The main RF output delivers typ. 11 dBm signal power to feed an antenna. A RC polyphase filter (PPF) is used for LO quadrature phase generation of the homodyne quadrature downconversion mixer. Output power sensors as well as a temperature sensor are implemented for monitoring purposes. The device is controlled via SPI and is manufactured in a 0.18 $\mu$ m SiGe:C technology offering a cutoff frequency of 200 GHz. The MMIC is packaged in a 32 pin leadless RoHS compliant VQFN package.

Product Name	Package	Chip	Marking
BGT24ATR12	VQFN32-9	T0825	BGT24ATR12

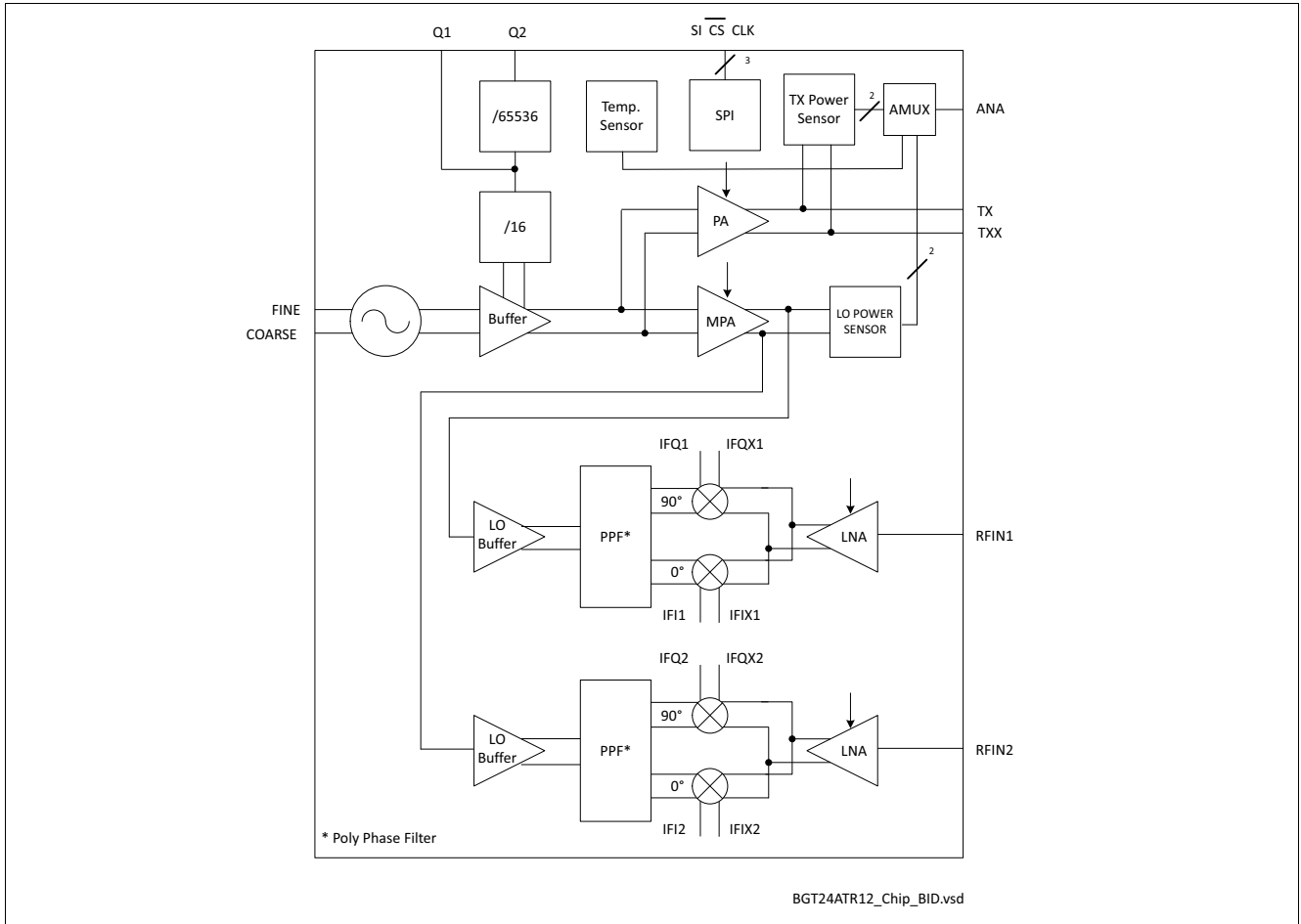

**Figure 1 BGT24ATR12 Block Diagram**



## 2 Electrical Characteristics

### 2.1 Absolute Maximum Ratings

$T_A = -40\text{ °C}$  to  $125\text{ °C}$ ; all voltages with respect to ground, positive current flowing into pin (unless otherwise specified)<sup>1)</sup>

**Table 1 Absolute Maximum Ratings**

Parameter	Symbol	Values			Unit	Note / Test Condition
		Min.	Typ.	Max.		
Supply voltage	$V_{CC}$	-0.3	–	3.6	V	–
DC voltage at RF Pins TX, TXX, RFIN1, RFIN2	$VDC_{RF}$	0	–	0	V	MMIC provides short circuit to GND for all RF pins
DC voltage at Pins IFI1/2, IFIX1/2, IFQ1/2, IFQX1/2	$VDC_{IF}$	0	–	Vcc	V	–
DC current into Pins IFI1/2, IFIX1/2, IFQ1/2, IFQX1/2	$I_{IF}$	-8.5	–	3.5	mA	max. values indicate current due to short circuit to GND and Vcc respectively
DC voltage at Pin ANA	$VDC_{ANA}$	-0.3	–	3.6	V	–
DC current into Pin ANA (Sink)	$I_{ANA\ SINK}$	125	350	500	$\mu$ A	max. values indicate current due to short circuit to GND and Vcc respectively
DC current into Pin ANA (Source)	$I_{ANA\ SOURCE}$	-7	–	–	mA	–
DC voltage at Pin Q1	$VDC_{Q1}$	Vcc-0.3	–	Vcc	V	–
DC current into Pin Q1	$I_{Q1}$	-8	–	12	mA	–
DC voltage at Pin Q2	$VDC_{Q2}$	-0.3	–	3.6	V	–
DC current into Pin Q2 enabled	$I_{Q2EN}$	-3	–	3	mA	–
DC current into Pin Q2 disabled	$I_{Q2DIS}$	-10	–	10	$\mu$ A	–
DC voltage at SPI input Pins SI, CLK, CS	$VDC_{SPIIN}$	-0.3	–	3.6	V	–
DC current into SPI input Pins SI, CLK, CS	$I_{SPIIN}$	–	–	3	mA	–
RF input power into Pins RFIN1, RFIN2	$P_{RF}$	–	–	0	dBm	–
DC voltage at Pins Fine, Coarse	$V_F, V_C$	0	–	5	V	–

1) Not subject to production test, specified by design

**Table 1 Absolute Maximum Ratings (cont'd)**

Parameter	Symbol	Values			Unit	Note / Test Condition
		Min.	Typ.	Max.		
DC current into Pins FINE, COARSE	$I_F, I_C$	-110	–	110	μA	Positive currents if $V_{TUNE} > V_{CC}$ ; Negative currents if $0V \leq V_F; V_C \leq V_{CC}$
Total power dissipation	$P_{DISS}$	–	–	1050	mW	With BIST deactivated
Junction temperature	$T_J$	-40	–	170	°C	–
Ambient temperature range	$T_A$	-40	–	125	°C	$T_A$ = temperature at package soldering point
Storage temperature range	$T_{STG}$	-40	–	150	°C	–

**Attention: Stresses exceeding the max. values listed here may cause permanent damage to the device. Exposure to absolute maximum rating conditions for extended periods may affect device reliability. Maximum ratings are absolute ratings; exceeding only one of these values may cause irreversible damage to the integrated circuit.**

## 2.2 Thermal Resistance

**Table 2 Thermal Resistance**

Parameter	Symbol	Values			Unit	Note / Test Condition
		Min.	Typ.	Max.		
Junction - soldering point <sup>1)</sup>	$R_{thJS}$	–	–	40	K/W	–

1) For calculation of  $R_{thJS}$  please refer to application note thermal resistance

## 2.3 ESD Integrity

**Table 3 ESD Integrity**

Parameter	Symbol	Values			Unit	Note / Test Condition
		Min.	Typ.	Max.		
ESD robustness, HBM <sup>1)</sup>	$V_{ESD-HBM}$	-1	–	1	kV	All pins
ESD robustness, CDM <sup>2)</sup>	$V_{ESD-CDM}$	-500	–	500	V	All pins

- 1) According to ANSI/ESDA/JEDEC JS-001 (R = 1.5kΩ, C = 100pF) for Electrostatic Discharge Sensitivity Testing, Human Body Model (HBM)-Component Level
- 2) According to JEDEC JESD22-C101 Field-Induced Charged Device Model (CDM), Test Method for Electrostatic-Discharge-Withstand Thresholds of Microelectronic Components

## 2.4 Measured RF Characteristics

### 2.4.1 Power Supply

**Table 4** Typical Characteristics  $T_A = -40 \dots 125 \text{ }^\circ\text{C}$ , SPI-Bit 4 = low

Parameter	Symbol	Values			Unit	Note / Test Condition
		Min.	Typ.	Max.		
Supply voltage	$V_{CC}$	3.135	3.3	3.465	V	–
Supply current	$I_{CC}$	150	210	270	mA	Max. TX output power, all prescalers are activated, LO and TX output buffer in high mode
Supply current - special condition	$I_{CC}$	–	–	250	mA	If $V_{CC,max}=3.3\text{V}$ and $T_{min}>-20^\circ\text{C}$

### 2.4.2 TX Section

**Table 5** Typical Characteristics  $T_A = -40 \dots 125 \text{ }^\circ\text{C}$ ,  $f = 24.0 \dots 24.25 \text{ GHz}$ , SPI-Bit 4 = low<sup>1)</sup>

Parameter	Symbol	Values			Unit	Note / Test Condition
		Min.	Typ.	Max.		
VCO frequency range	$f_{VCO}$	24.0	–	24.25	GHz	–
VCO fine tuning voltage <sup>2)</sup>	$V_F$	0.8 <sup>3)</sup>	–	3.0	V	$0.8\text{V} \leq V_F \leq 1.25\text{V}$ for $V_{C_{MIN}}=0.75\text{V}$ , $1.25\text{V} \leq V_F \leq 3.0\text{V}$ for $V_{C_{MIN}}=0.75\text{V}+1.7\text{V} \cdot (V_F-1.25\text{V})/1.75\text{V}$ , see Figure 2 on Page 12
VCO coarse tuning voltage <sup>2)</sup>	$V_C$	0.75 <sup>3)</sup>	–	3.0	V	$0.75\text{V} \leq V_C \leq 1.35\text{V}$ for $V_{F_{MIN}}=0.8\text{V}$ , $1.35\text{V} \leq V_C \leq 3.0\text{V}$ for $V_{F_{MIN}}=V_C-0.55\text{V}$ , see Figure 2 on Page 12
VCO tuning slope FINE	$\Delta f / \Delta V_F$	200	–	1000	MHz/V	$24\text{GHz} \leq f \leq 24.25\text{GHz}$ see Figure 2 on Page 12
VCO tuning slope COARSE	$\Delta f / \Delta V_C$	400	–	2000	MHz/V	$24\text{GHz} \leq f \leq 24.25\text{GHz}$ see Figure 2 on Page 12
VCO temperature drift	$\Delta f / \Delta T$	-10	-6	0	MHz/K	Min @ $T = -40^\circ\text{C}$
VCO pushing	$\Delta f / \Delta V_{CC}$	-350	60	350	MHz/V	Absolute values

- 1) Performance based on Application Circuit Figure 3 on Page 16, Cross Section of Application Board, Compensation Structures and Application Board Layout Figure 5 on Page 22ff and Footprint Figure 9 on Page 25
- 2) At tuning pins chipinternal pull-up of  $60k\Omega \pm 20\%$  to VCC; max.- and min. temperature tuning voltage limits are chosen in a way that they can be linearly interpolated within operating temperature range
- 3) Specified min. value for temperature  $\leq 25^\circ\text{C}$ ; min. value for temperatures  $>25^\circ\text{C}$  is based on following formular  $V_{\text{CMIN}} = V_{\text{FMIN}} = 0.8\text{V} + 0.4\text{V} * (T [^\circ\text{C}] - 25^\circ\text{C}) / 100^\circ\text{C}$

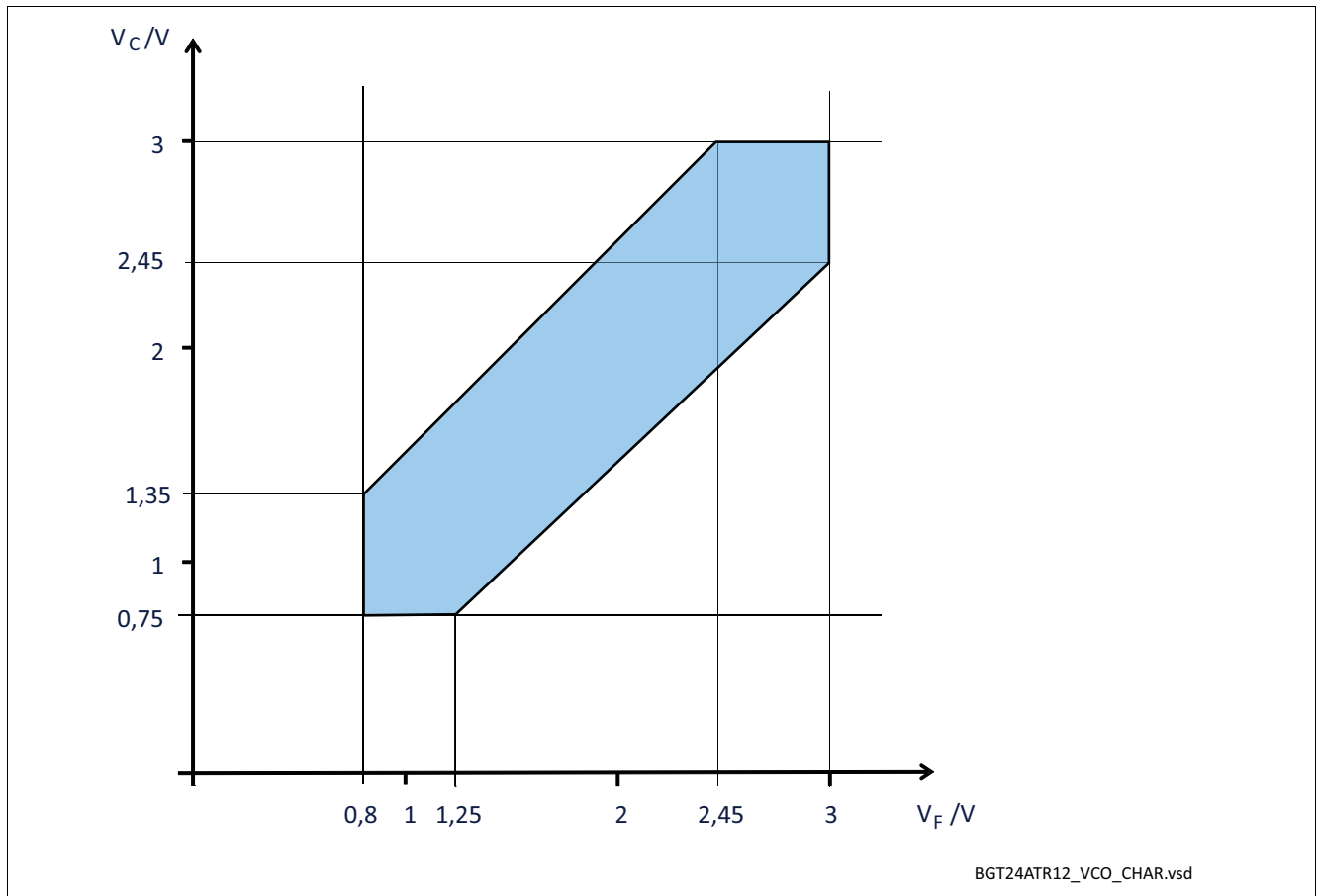

**Figure 2 VCO Tuning Window**

**Table 6 Typical Characteristics  $T_A = -40 .. 125^\circ\text{C}$ ,  $f = 24.0 .. 24.25\text{ GHz}$ , SPI-Bit 4 = low<sup>1)</sup>**

Parameter	Symbol	Values			Unit	Note / Test Condition
		Min.	Typ.	Max.		
VCO phase noise	$P_N$	–	-85	-75	dBc/Hz	@ 100kHz offset, $V_F = V_C$
TX/TXX load impedance	$Z_{\text{TX}}$ $Z_{\text{TXX}}$	–	20.8-j20.2 19.5-j11.7	–	$\Omega$	Typical value at 24.125GHz and VSWR $\leq 2:1$
Max. TX output power	$P_{\text{TX}}$	6	11	15	dBm	–
Max. TX output power for $V_{\text{CC}} = 3.3\text{V} \pm 50\text{mV}$	$P_{\text{TX}}$	6.5	11	14.5	dBm	–
TX output power adjustable range	$a_{\text{TX}}$	3	9	–	dB	Adjustable via SPI

**Table 6** Typical Characteristics  $T_A = -40 \dots 125 \text{ }^\circ\text{C}$ ,  $f = 24.0 \dots 24.25 \text{ GHz}$ , SPI-Bit 4 = low<sup>1)</sup>

Parameter	Symbol	Values			Unit	Note / Test Condition
		Min.	Typ.	Max.		
TX output power in "off" mode <sup>2)</sup>	$P_{\text{TXoff}}$	–	–	-30	dBm	Parameter based on IFX eval board design
Q1 Prescaler division ratio	$D_{\text{Q1}}$	–	$2^4$	–	–	–
Q1 Prescaler output power	$P_{\text{Q1}}$	-14	-9	-4	dBm	Q1 loaded with 50 Ohm (AC- coupled)
Q1 output impedance <sup>2)</sup>	$Z_{\text{Q1}}$	–	50	–	$\Omega$	–
Q2 Prescaler division ratio	$D_{\text{Q2}}$	–	$2^{20}$	–	–	–
Q2 Prescaler max. output voltage	$V_{\text{maxQ2}}$	2.4	–	–	V	Test condition: Q2 loaded with high impedance probe (1 MOhm, 13 pF)
Q2 Prescaler min. output voltage	$V_{\text{minQ2}}$	–	–	0.8	V	Test condition: Q2 loaded with high impedance probe (1 MOhm, 13 pF)
Q2 Prescaler max. output source current	$I_{\text{maxsource Q2}}$	1.2	–	–	mA	Test condition: Q2 loaded with 50 Ohm to Vcc
Q2 Prescaler max. output sink current	$I_{\text{maxsink Q2}}$	1.2	–	–	mA	Test condition: Q2 loaded with 50 Ohm to Vcc
Q2 Prescaler output resistance in disable mode	$R_{\text{Q2,DIS}}$	100	–	–	k $\Omega$	–

1) Performance based on Application Circuit Figure 3 on Page 16, Cross Section of Application Board, Compensation Structures and Application Board Layout Figure 5 on Page 22ff and Footprint Figure 9 on Page 25

2) Guaranteed by device design

### 2.4.3 RX Section

**Table 7 Typical Characteristics  $T_A = -40 \dots 125 \text{ }^\circ\text{C}$ ,  $f = 24.0 \dots 24.25 \text{ GHz}$ , SPI-Bit 4 = low<sup>1)</sup>**

Parameter	Symbol	Values			Unit	Note / Test Condition
		Min.	Typ.	Max.		
RFIN frequency range	$f_{\text{RFIN}}$	24.0	–	24.25	GHz	–
RFIN port impedance <sup>2)</sup>	$Z_{\text{RFIN1}}$ $Z_{\text{RFIN2}}$	–	15.9-j18.4 15.7-j18.9	–	$\Omega$	Typical value at 24.125GHz and $\text{VSWR} \leq 2:1$
RFIN VSWR	VSWR	–	–	2:1	–	At load port of off chip compensation network as proposed
IF frequency range	$f_{\text{IF}}$	0	–	10	MHz	–
IF output impedance	$Z_{\text{IF}}$	850	1000	1150	$\Omega$	–
Leakage LO to RFIN	$L_{\text{LO} \rightarrow \text{RFIN}}$	–	–	-30	dBm	LO Signal Power @ RFIN Port, Parameter based on IFX eval board design
Isolation RFIN1 to RFIN2	$I_{\text{RFIN1-RFIN2}}$	30	–	–	dB	Parameter based on IFX eval board design
Voltage conversion gain <sup>3)</sup>	$G_C$	19	26	31	dB	$R_{\text{LOAD,IF}} > 10 \text{ k}\Omega$
LNA gain reduction	$\Delta G_{\text{CLG}}$	3	5	8	dB	–
SSB noise figure	$N_{\text{SSB}}$	–	12	20	dB	Single sideband at $f_{\text{IF}} = 100 \text{ kHz}$
IF 1/f corner frequency	$f_c$	–	10	20	kHz	–
Input compression point	$IP_{1\text{dB}}$	-17	-12	–	dBm	–
Input 3rd order intercept point	$IIP3$	-8	-4	–	dBm	–
Quadrat. phase imbalance	$\varepsilon_p$	-10	–	10	deg	–
Quadrat. phase imbalance over temperature and aging of both receivers	$\Delta\varepsilon_p$	-8	–	8	deg	–
Quadrat. amplitude imbalance	$\varepsilon_A$	-1	–	1	dB	–
Quadrat. amplitude imbalance over temperature and aging of both receivers	$\Delta\varepsilon_A$	-0.5	–	0.5	dB	–

1) Performance based on Application Circuit Figure 3 on Page 16, Cross Section of Application Board, Compensation Structures and Application Board Layout Figure 5 on Page 22ff and Footprint Figure 9 on Page 25

2) Guaranteed by device design

3) Lowest gain at high temperature, highest gain at low temperature

## 2.5 Temperature Sensor

Monitoring of the chip temperature is provided by the on-chip temperature sensor which delivers temperature-proportional voltage.

**Table 8 Typical Characteristics Temperature Sensor  $T_A = -40 .. 125\text{ }^\circ\text{C}^1$**

Parameter	Symbol	Values			Unit	Note / Test Condition
		Min.	Typ.	Max.		
Temperature range	$T_{\text{TSENS}}$	-40	–	125	$^\circ\text{C}$	–
Output temperature voltage	$V_{\text{OUT,TEMP}}$	–	1.50	–	V	@ 25 $^\circ\text{C}$
Sensitivity	$S_{\text{TSENS}}$	–	4.5	–	mV/K	–
Overall accuracy error	$Err_{\text{TSENS}}$	–	–	$\pm 15$	K	–

1) all voltages with respect to ground, positive current flowing into pin (unless otherwise specified)

## 2.6 Power Detector

For RF power indication, peak voltage detectors are connected to the output of the TX power amplifier and to the LO medium power amplifier. To eliminate temperature and supply voltage variations, a reference output  $V_{\text{REF}}$  is available through the ANA output for the TX and LO power sensor. The compensated detector output voltage is given by the difference between  $V_{\text{OUT}}$  and  $V_{\text{REF}}$  for both power sensors respectively. This voltage is proportional to the RF voltage swing at the individual amplifier outputs, its characteristic is non-directional.

**Table 9 Typical Characteristics Power Detector  $T_A = -40 .. 125\text{ }^\circ\text{C}$ ,  $V_{\text{CC}} = 3.3\text{ V}^1$**

Parameter	Symbol	Values			Unit	Note / Test Condition
		Min.	Typ.	Max.		
Power range	$P_{\text{PSENS}}$	-10	–	15	dBm	–
TX power sensor	$V_{\text{OUT,TX}}$ - $V_{\text{REF,TX}}$	–	550	–	mV	@ $P_{\text{TX}} = 11\text{ dBm}$
LO power sensor	$V_{\text{OUT,LO}}$ - $V_{\text{REF,LO}}$	–	50	–	mV	@ typ. internal $P_{\text{LO}}$

1) all voltages with respect to ground, positive current flowing into pin (unless otherwise specified)

### 3 Application Circuit and Block Diagram

#### 3.1 Application Circuit Schematic

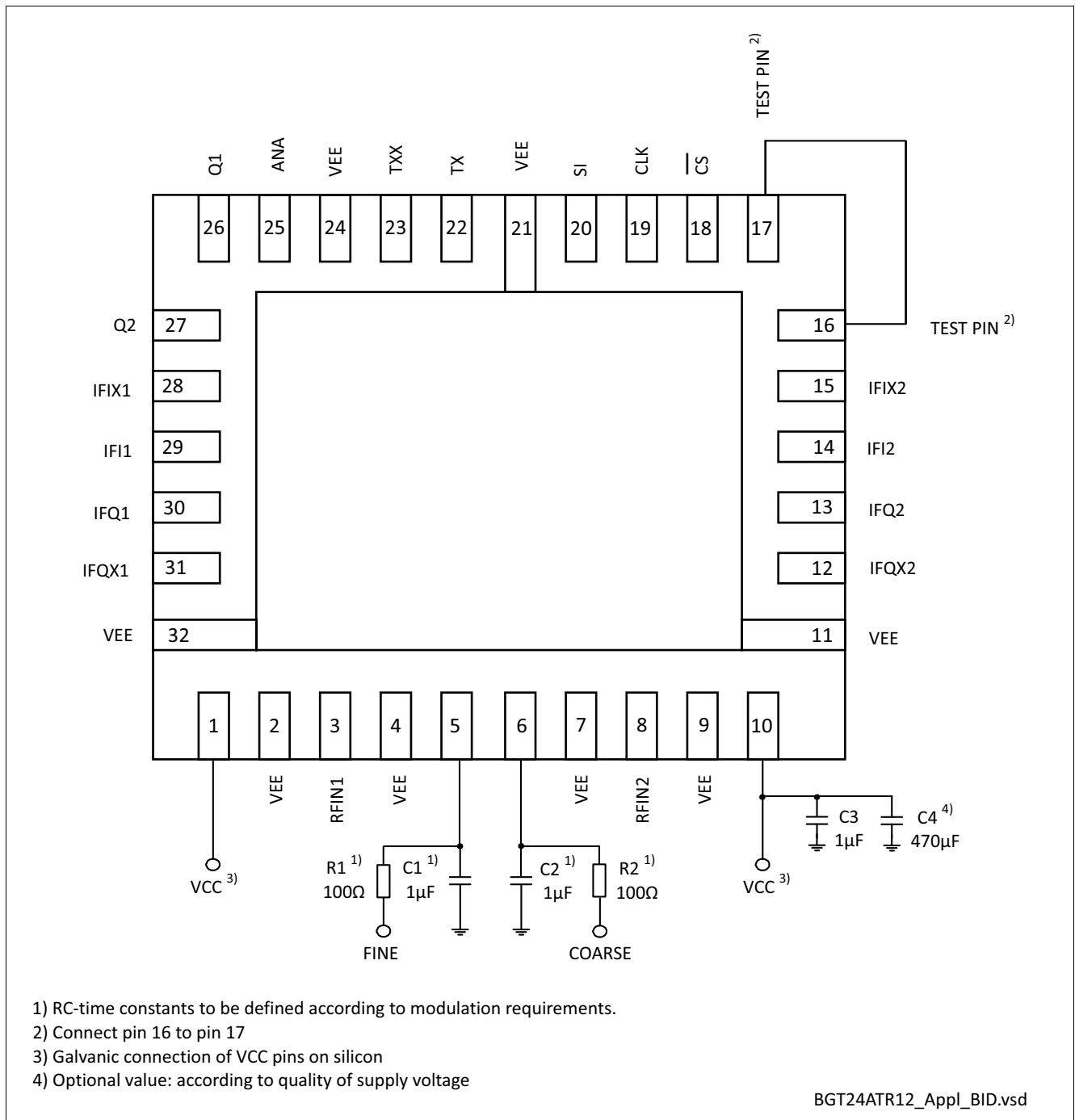

Figure 3 Application Circuit with Chip Outline (Top View)



**Table 10 Bill of Materials**

<b>Part Number</b>	<b>Part Type</b>	<b>Manufacturer</b>	<b>Size</b>	<b>Comment</b>
C1 ... C4	Chip capacitor	Various	Various	–
R1 ... R2	Chip resistor	Various	0402	–

### 3.2 Pin Description

**Table 11 Pin Definition and Function**

Pin No.	Name	Function
1	VCC	Supply voltage
2	VEE	Ground
3	RFIN1	RF input downconverter 1
4	VEE	Ground
5	FINE	VCO fine tuning input
6	COARSE	VCO coarse tuning input
7	VEE	Ground
8	RFIN2	RF input downconverter 2
9	VEE	Ground
10	VCC	Supply voltage
11	VEE	Ground
12	IFQX2	Complementary quadrature phase IF output downconverter 2
13	IFQ2	Quadrature phase IF output downconverter 2
14	IFI2	In phase IF output downconverter 2
15	IFIX2	Complementary in phase IF output downconverter 2
16	TEST PIN	Test pin; DC coupled pin
17	TEST PIN	Test pin; DC coupled pin
18	$\overline{\text{CS}}$	Chip select input SPI (inverted)
19	CLK	Clock input SPI block
20	SI	Data input SPI block
21	VEE	Ground
22	TX	Transmit output
23	TXX	Complementary transmit output
24	VEE	Ground
25	ANA	Analog output
26	Q1	Prescaler output 1.5GHz
27	Q2	Prescaler output 23kHz
28	IFIX1	Complementary in phase IF output downconverter 1
29	IFI1	In phase IF output downconverter 1
30	IFQ1	Quadrature phase IF output downconverter 1
31	IFQX1	Complementary quadrature phase IF output downconverter 1
32	VEE	Ground

### 3.3 SPI

1.) Three signals control the serial peripheral interface of the BGT24ATR12:

SI (Data); CLK (Clock);  $\overline{CS}$  (Chip select)

2.) The data bits SI (MSB first) are read in the shift with falling edge of the CLK signal.

Please make sure, that the data is present at least 10 ns before and at least 10 ns after the falling edge of the clock signal.

3.) The CLK and  $\overline{CS}$  signals are combined internally.

At least 20 ns before first rising edge of the first CLK signal  $\overline{CS}$  needs to be in "low" state.

While the Data is read,  $\overline{CS}$  has to remain in "low" state.

4.) When Data read in is finished, the shift register content will be written in the latch at the rising edge of the  $\overline{CS}$  signal. The time between the last falling edge of the CLK signal and the rising edge of the  $\overline{CS}$  must be at least 20 ns.

**Table 12 SPI Block Data Bit Description**

Data Bit	Name	Description (Logic High)	Power ON State
15	GS	LNA Gain reduction	low
14	–	Not used	low
13	AMUX2	Analog multiplexer control bit 2	high
12	DIS_PA	Disable Power Amplifier	high
11	Test Bit	Test bit, must be low otherwise malfunction	low
10	Test Bit	Test bit, must be low otherwise malfunction	low
9	Test Bit	Test bit, must be low otherwise malfunction	low
8	AMUX1	Analog multiplexer control bit 1	low
7	AMUX0	Analog multiplexer control bit 0	low
6	DIS_DIV64k	Disable 64k divider	low
5	DIS_DIV16	Disable 16 divider	low
4	PC2_BUF	High LO buffer output power, need to be low otherwise increased current consumption	low
3	PC1_BUF	High TX buffer output power	low
2	PC2_PA	TX power reduction bit 2	high
1	PC1_PA	TX power reduction bit 1	high
0	PC0_PA	TX power reduction bit 0	high

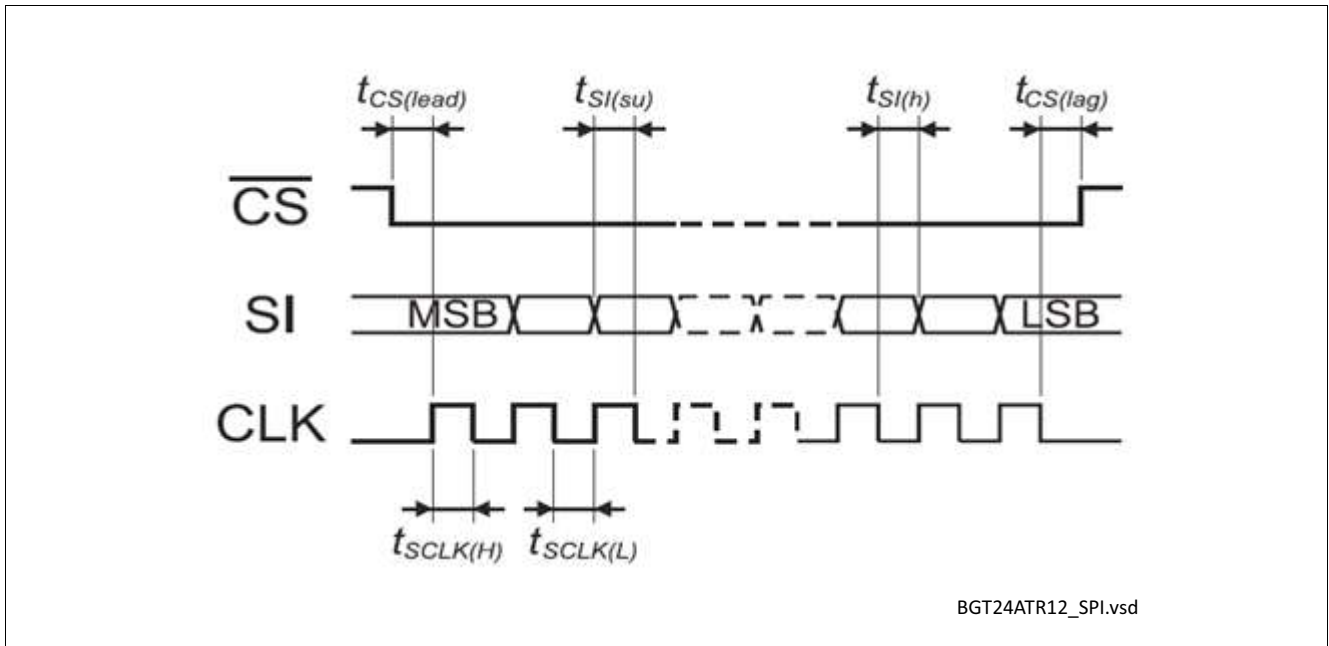

Figure 4 Timing Diagram of the SPI

Table 13 SPI Timing and Logic Levels

Parameter	Symbol	Values			Unit
		Min.	Typ.	Max.	
Serial clock frequency	$f_{SCLK}$	0	–	50	MHz
Serial clock high time	$f_{SCLK(H)}$	10	–	–	ns
Serial clock low time	$t_{SCLK(L)}$	10	–	–	ns
Chip select lead time	$t_{CS(lead)}$	20	–	–	ns
Chip select lag time	$t_{CS(lag)}$	20	–	–	ns
Data setup time	$t_{SI(su)}$	10	–	–	ns
Data hold time	$t_{SI(h)}$	10	–	–	ns
Low level (SI, CLK, $\overline{CS}$ )	$V_{IN(L)}$	0	–	0.8	V
High level (SI, CLK, $\overline{CS}$ )	$V_{IN(H)}$	2.0	–	$V_{CC}$	V
Input capacitance (SI, CLK, $\overline{CS}$ )	$C_{IN}$	–	–	2	pF
Input current (SI, CLK, $\overline{CS}$ )	$I_{IN}$	-150	–	150	$\mu A$

Table 14 Truth Table AMUX

Output signal ANA	AMUX2	AMUX1	AMUX0
$V_{OUT,TX}$	low	low	low
$V_{REF,TX}$	low	low	high
$V_{OUT,LO}$	low	high	low
$V_{REF,LO}$	low	high	high
$V_{TEMP}$	high	low	low
Test_Signal1	high	low	high

**Table 14 Truth Table AMUX (cont'd)**

<b>Output signal ANA</b>	<b>AMUX2</b>	<b>AMUX1</b>	<b>AMUX0</b>
Test_Signal2	high	high	low
Test_Signal2	high	high	high

### 3.4 Application Board

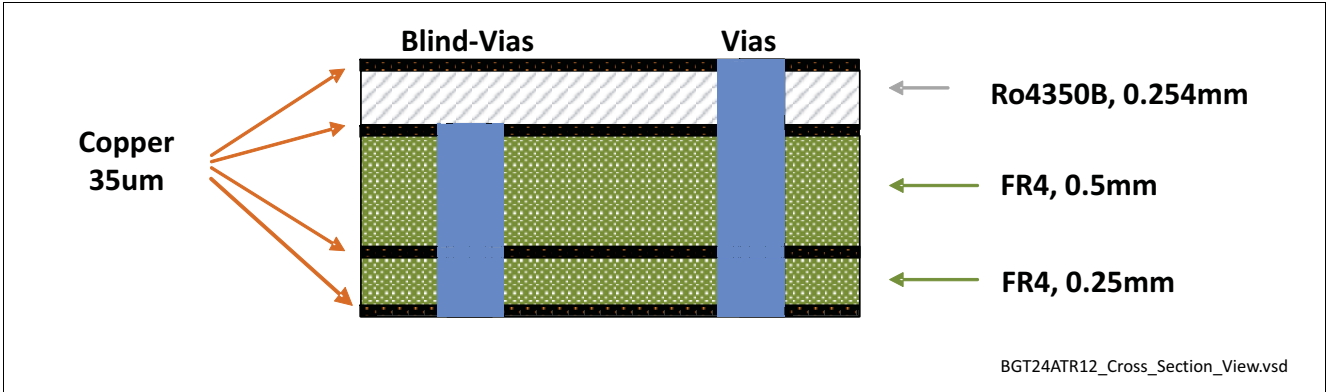

Figure 5 Cross-Section View of Application Board

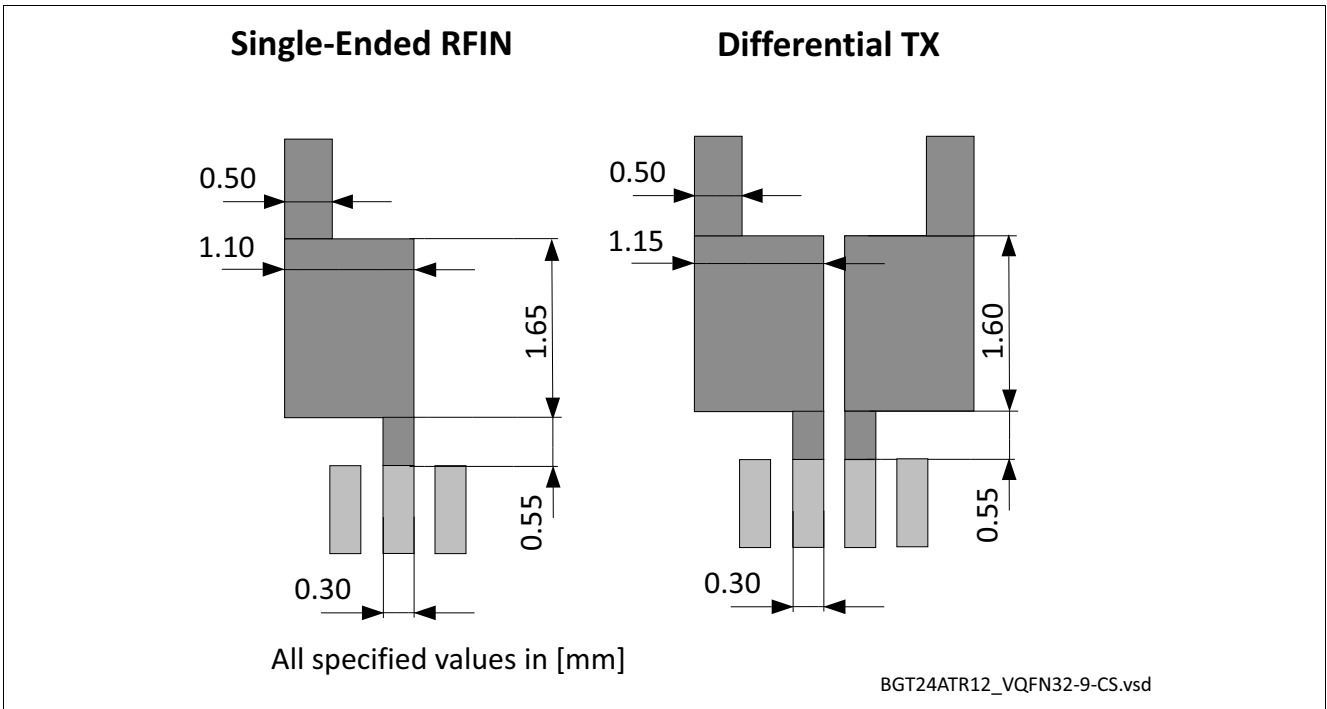
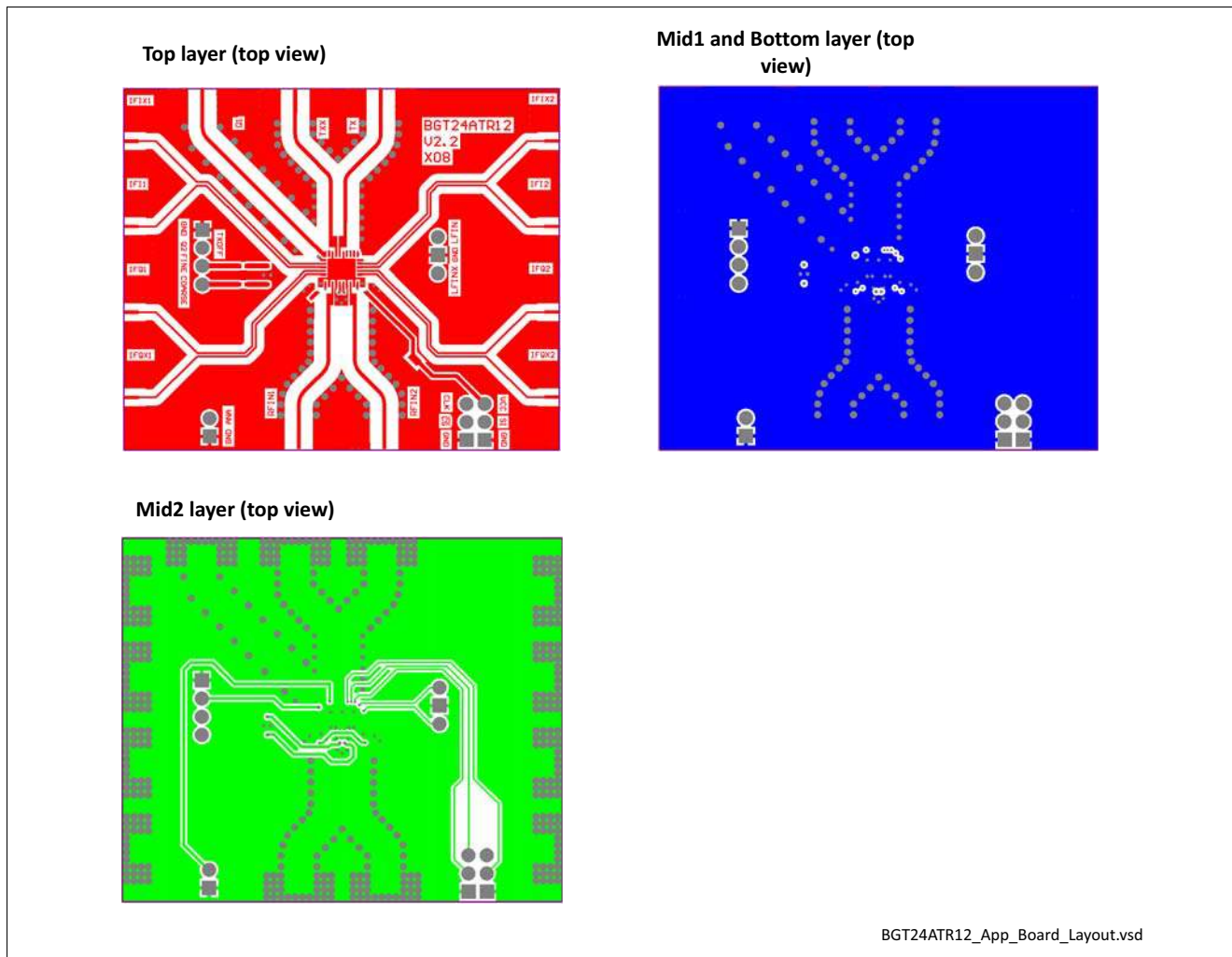

Figure 6 Detail of Compensation Structure (valid for appl. board mat. Ro4350B, 0.254mm acc. to Fig. 5)



**Figure 7 Application Board Layout**

*Note: In order to achieve the same performance as given in this datasheet please follow the suggested PCB-layout. The compensation structure is critical for RF performance. Via holes as recommended on one of next pages (not shown above).*

### 3.5 Equivalent Circuit Diagram of MMIC Interfaces

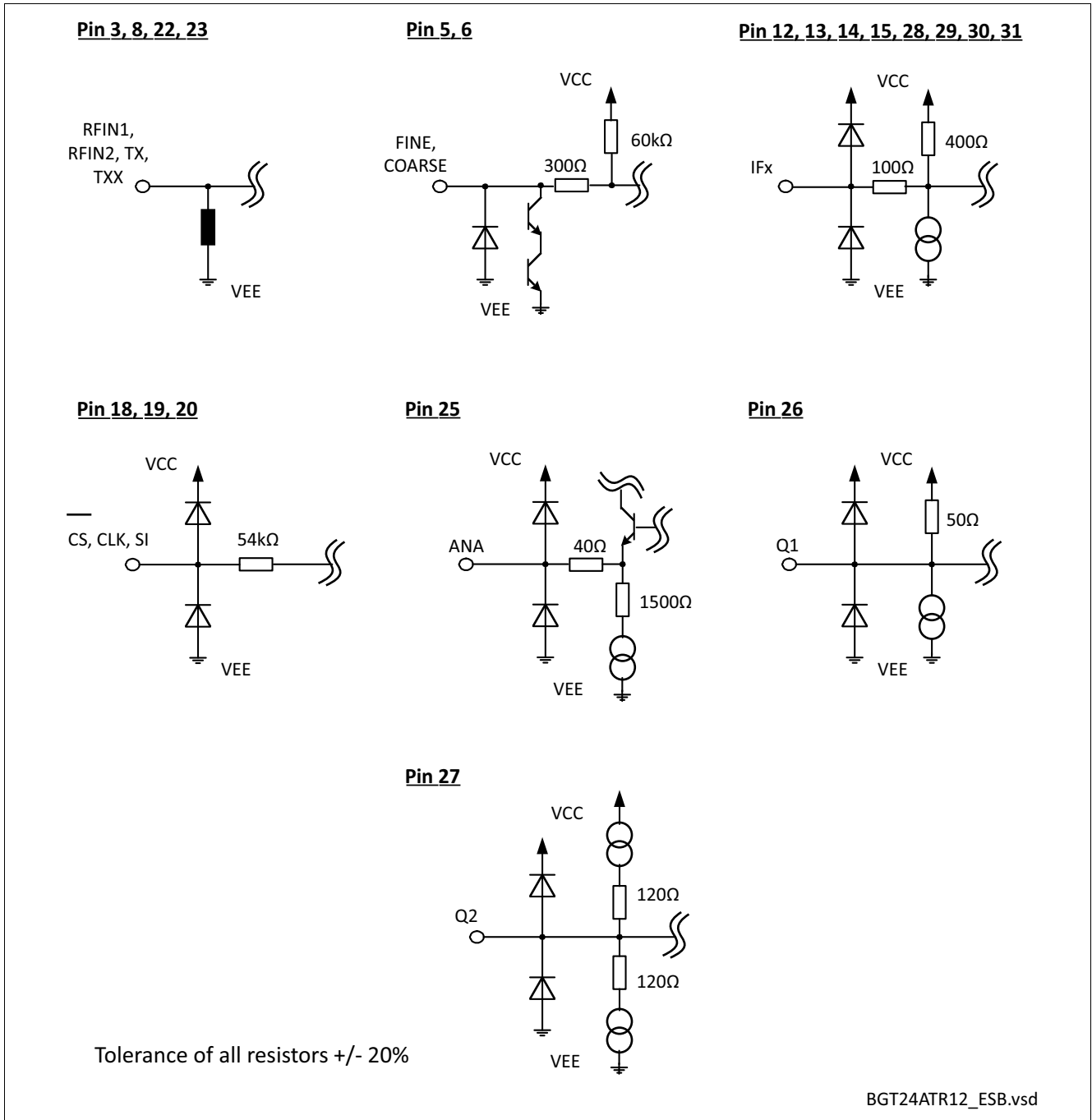

Figure 8 Equivalent Circuit Diagram of MMIC Interfaces



## 4 Physical Characteristics

### 4.1 Package Footprint

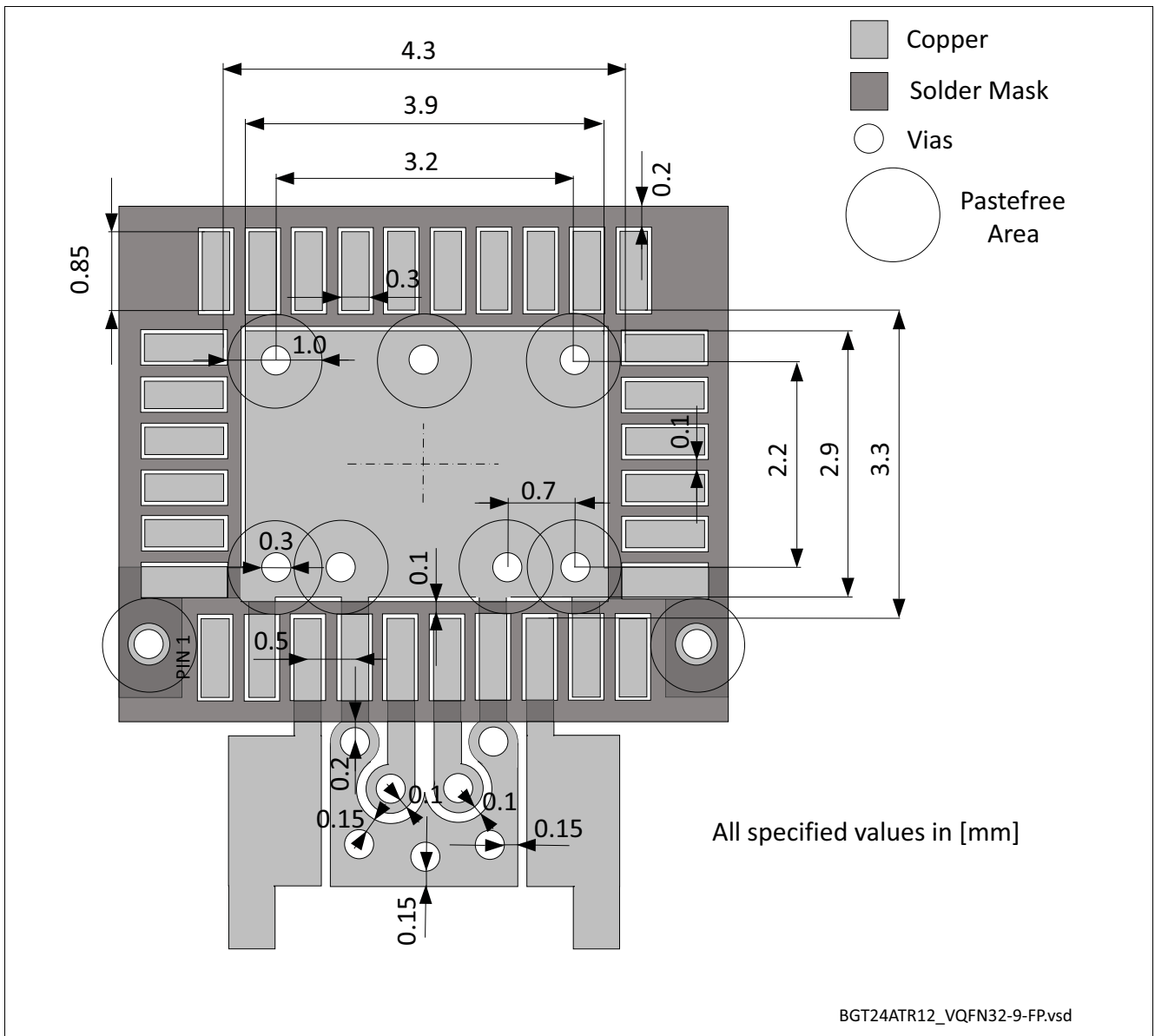

Figure 9 Recommended Footprint and Stencil Layout for the VQFN32-9 Package

## 4.2 Reflow Profile

Soldering process qualified during qualification with "Preconditioning MSL-3: 30°C. 60%r.h., 192h, according to JEDEC JSTD20".

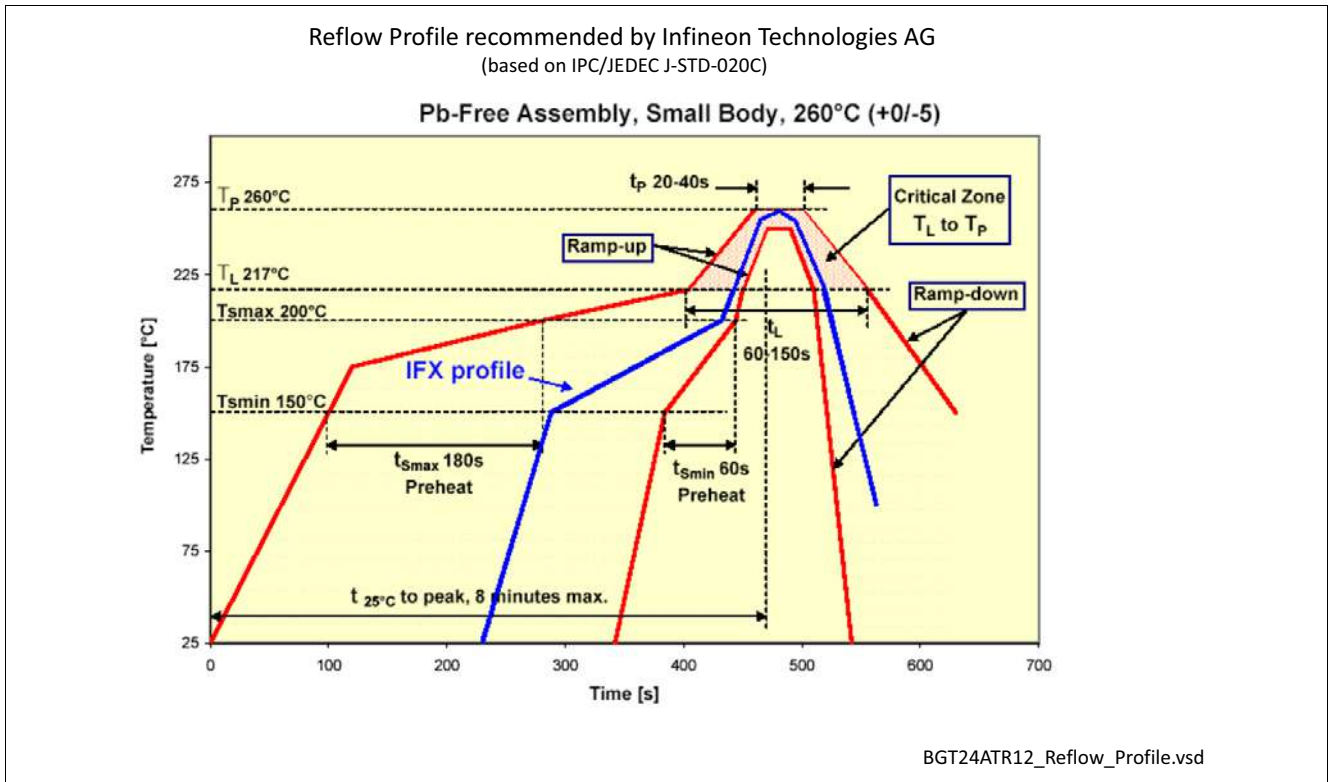

Figure 10 Reflow Profile for BGT24ATR12 (VQFN32-9)

### 4.3 Package Dimensions

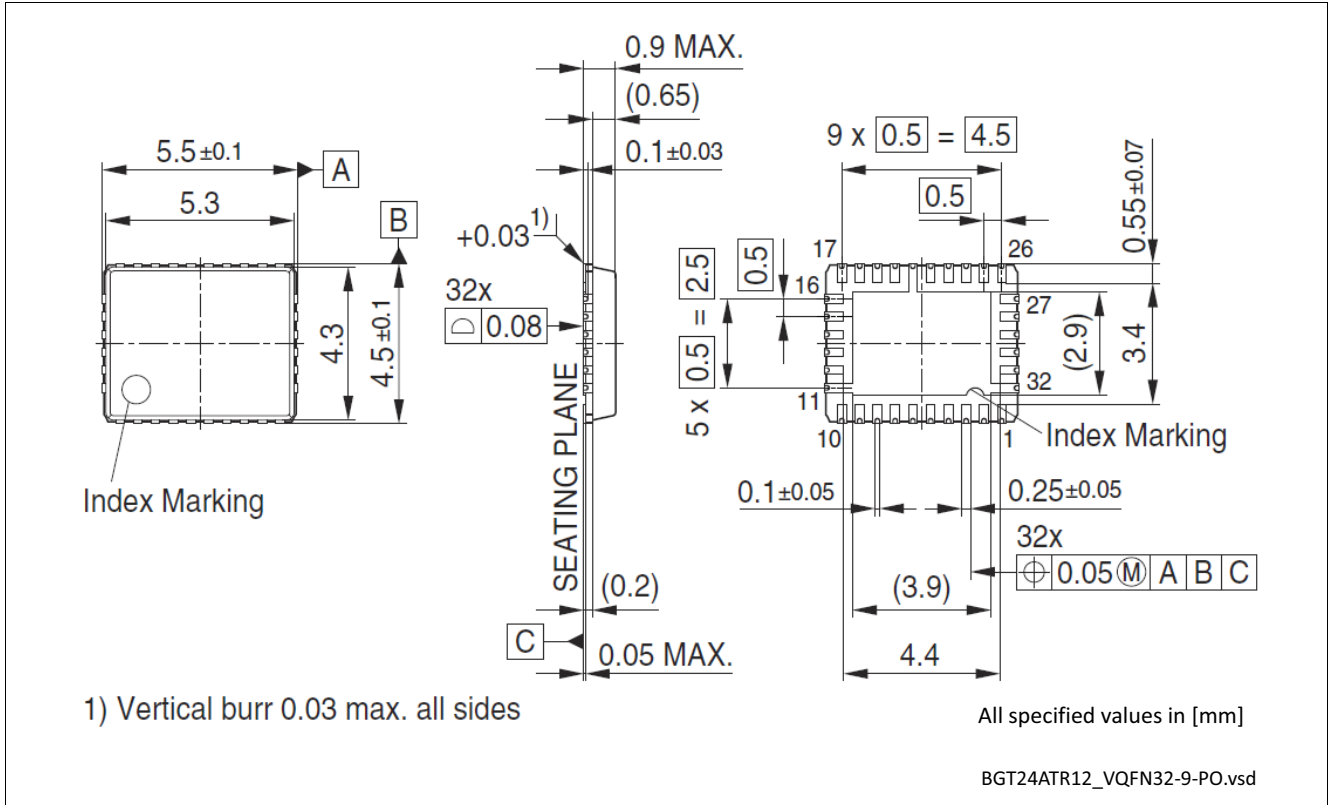

Figure 11 Package Outline (Top, Side and Bottom View)

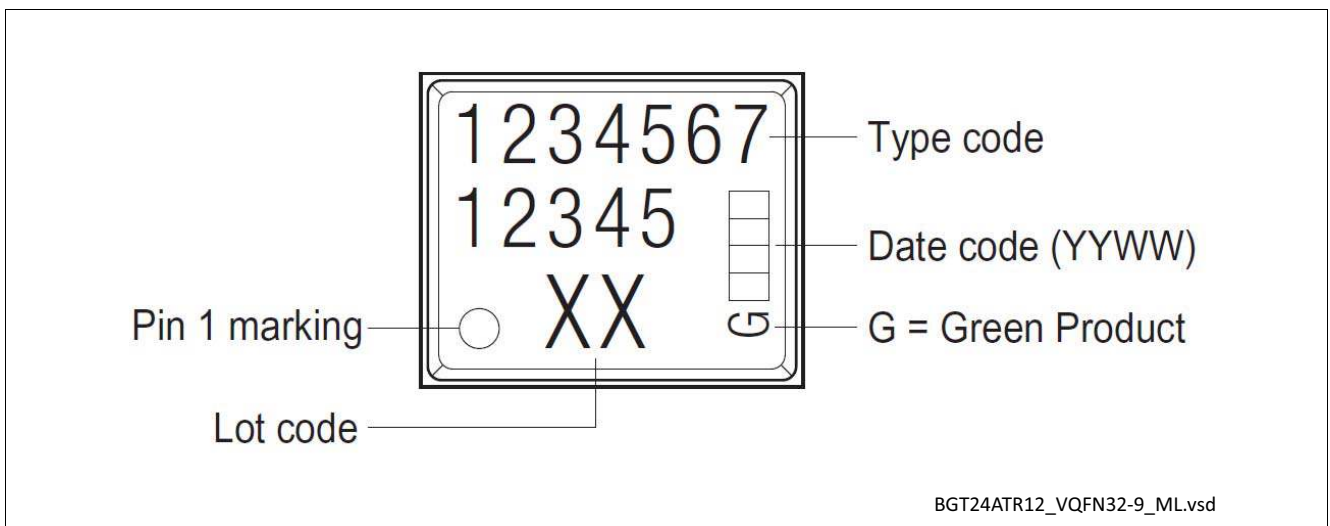
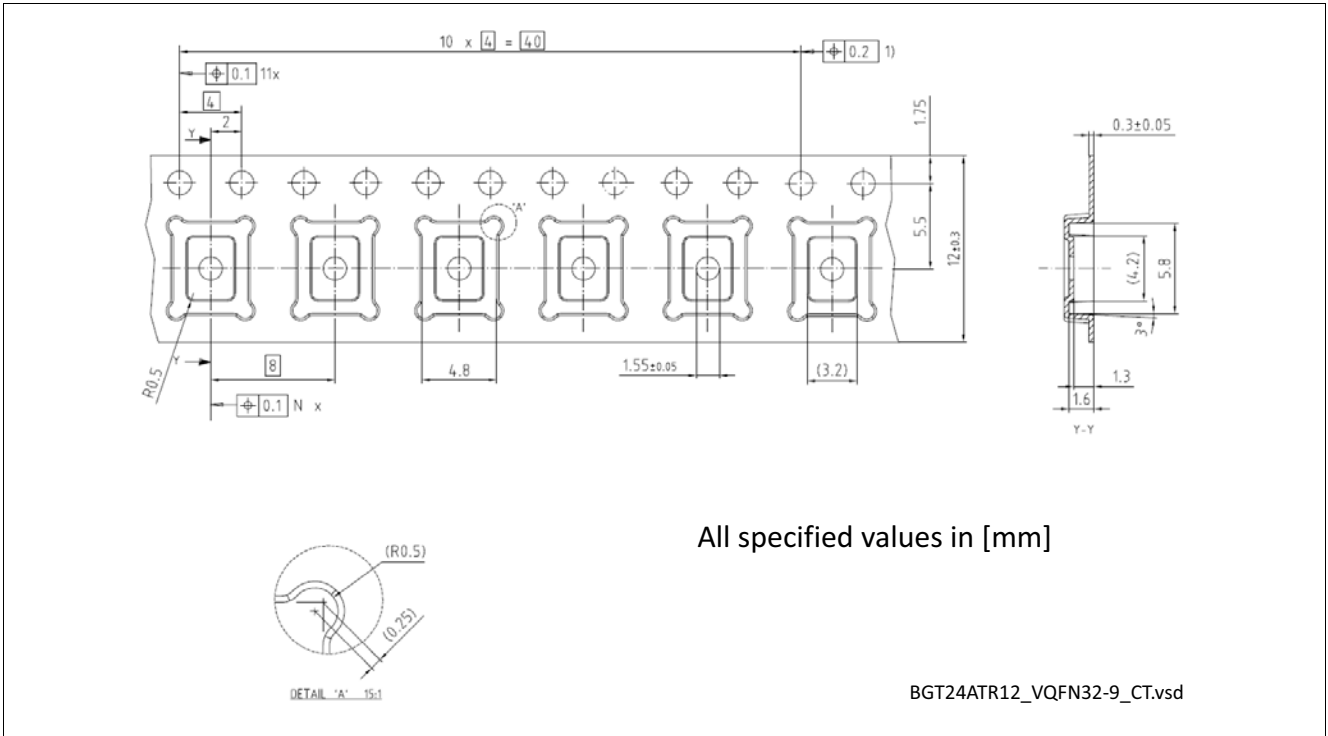

Figure 12 Marking Layout VQFN32-9



**Figure 13** Tape of VQFN32-9

[www.infineon.com](http://www.infineon.com)

Published by Infineon Technologies AG