

Copyright FCI
 FCIconnect.com

PRODUCT NO.
 SEE TABLE

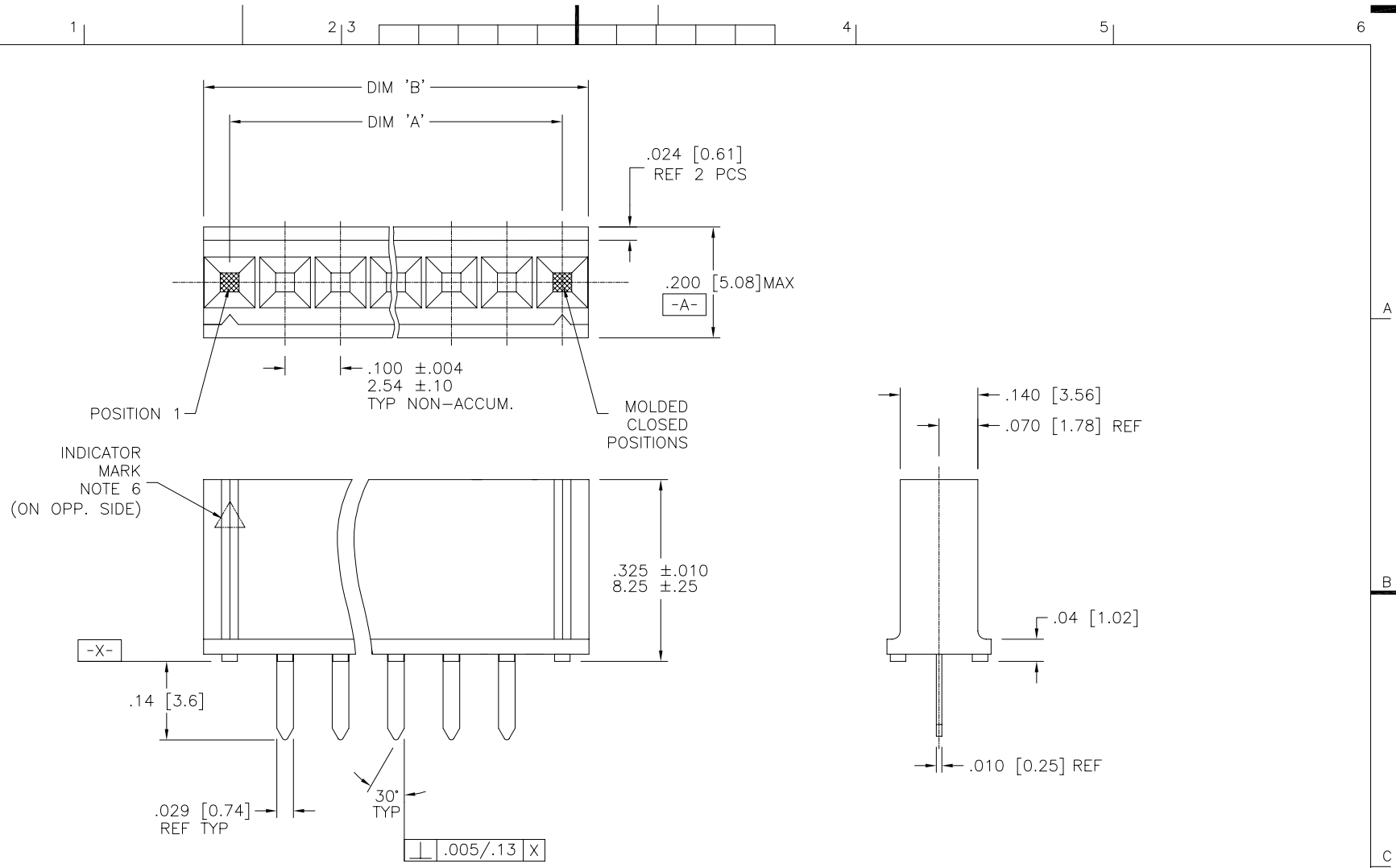

mat'l. code		surface ISO 1302 ✓		tolerance ISO 406 ISO 1101		projection ⊕		product family VCC	
ltr	ecn no	dr	date	tolerances unless otherwise specified		INCH/MM		title	
B	V70477	MDF	8/4/97	angles	linear	.XX±.01/.X±.3		VERT. CARD CONN. .100 @ SINGLE	
C	V71562	SAR	11/17/97			.XXX±.0.005/.XX±.13		ROW W/MOLDED CLOSE POSITIONS	
D	V80473	SAR	5/8/98	0°±2'		.XXXX±.0020/.XXX±.051		scale 4:1	
E	V81214	EPK	9/17/98	dr	S.ROYER	6/29/95		dwg no sheet 1 of 2 size	
F	M06-0229	ERE	10/11/05	enr	H.SUNDY	6/29/95		90332 A3	
G	M06-0210	MHT	6/03/06	chr	H.SUNDY	6/29/95		type Product Customer Drawing	
H	M07-0143	ERE	03/03/07	appd	H.SUNDY	6/29/95			
sheet index	revision	H	H						
	sheet	1	2						

PRODUCT NO.	SIZE	DIM 'A'	DIM 'B'	MOLDED CLOSED POSITION	TERM. PLATING	LEAD FREE OPTION
90332-001	1 x 19	1.800/45.72	1.895/48.13	1 AND 19	NOTE 5	NOTE 7, 8 & 10
90332-002	1 x 12	1.100/27.94	1.195/30.35	7	NOTE 2	

NOTES:

- ① HOUSING MATERIAL:
FILLED POLYESTER, FLAME RETARDENT PER UL 94V-0.
COLOR: BLACK
- ② TERMINAL MATERIAL:
BODY: BRASS
SPRING: BeCu, HEAT TREATED
BODY PLATING: 30u"/0.76u Au OVER 50u"/1.27u MIN Ni IN CONTACT AREA.
100u"/2.54u Sn (NOTE 10) OVER 50u"/1.27u Ni ON SOLDER TAIL.
SPRING PLATING: GOLD FLASH
- ③ PRODUCT TO BE MARK FCI PART NUMBER AND DATE CODE LEGIBLE ON TUBE LABEL.
4. APPLICATION INFORMATION:
A. RECOMMENDED MOUNTING HOLE PATTERN IS SHOWN IN FIG. 'A'.
B. ALL MATING PINS TO BE .025/0.64 SQUARE ON TRUE CENTER OF GIVEN TERMINAL SPACINGS WITHIN .015/0.38 DIAMETER.
C. SUGGESTED MATING PIN LENGTH, .210 ±.020/5.33 ±.51.
5. TERMINAL MATERIAL:
BODY: BRASS
SPRING: BeCu, HEAT-TREATED
BODY PLATING: 100µ/2.54µm Sn (NOTE 10) OVER 30µ/0.76µm Cu
SPRING PLATING: GOLD FLASH.
- ⑥ TRIANGLE MARK INDICATES POSITION #1 AND LOCATED ON OPPOSITE SIDE OF "V" NOTCH AS SHOWN.
- ⑦ ADD "LF" SUFFIX AT THE END OF PART NUMBER FOR LEAD FREE OPTION.
- ⑧ THESE PRODUCTS MEET EUROPEAN UNION DIRECTIVES AND OTHER COUNTRY REGULATIONS AS DESCRIBED IN GS-22-008.
9. THIS PART WILL WITHSTAND EXPOSURE TO 260°C PEAK TEMPERATURE FOR 20 SECONDS IN WAVE SOLDER, INFRA-RED OR VAPOR PHASE SOLDER PROCESS.
- ⑩ "THIS PRODUCT HAS 100% TIN PLATING IN THE INTERFACE AND HAS NOT BEEN TESTED FOR WHISKER GROWTH IN ALL INTERCONNECT ENVIRONMENTS."

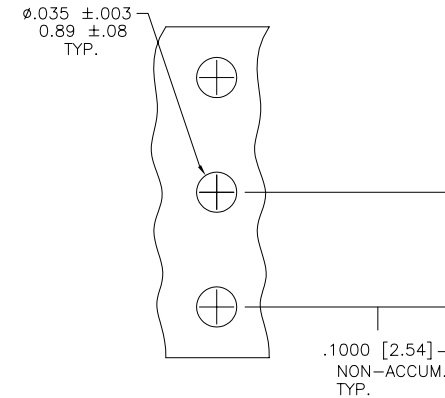

FIG. A



FCIconnect.com

Copyright FCI

mat'l. code		surface ISO 1302 ✓		tolerance ISO 406 ISO 1101		projection ⊕		product family VCC	
ltr	ecn	no	dr	date		tolerances unless otherwise specified		title	
H						angles	linear	INCH/MM	
						0°±2'	.XX±.01/.X±.3 .XXX±.0.005/.XX±.13 .XXXX±.0020/.XXX±.051	scale 4:1	
			dr	S.ROYER	6/29/95	FCI		dwg no	
			enr	H.SUNDY	6/29/95			sheet 2 of 2 size	
			chr	H.SUNDY	6/29/95			90332 A3	
			appd	H.SUNDY	6/29/95			type Product Customer Drawing	
sheet index	revision sheet								

form: A3