

THIS DRAWING IS UNPUBLISHED. RELEASED FOR PUBLICATION  
 © COPYRIGHT - By - ALL RIGHTS RESERVED.

LOC		DIST		REVISIONS			
P	LTR	DESCRIPTION		DATE	DWN	APVD	
	B	REV PER ECO 14-015941		12-1-14	CT	WM	

COMPONENT	MATERIAL	FINISH
HOUSING BUSHING COUPLING NUT CLAMP NUT	STAINLESS STEEL PER ASTM-A484 AND ASTM- A582, TYPE 303	PASSIVATE PER QQ-P-35
DIELECTRIC	TFE FLUOROCARBON PER ASTM-D-1457	N/A
CENTER CONTACT	BERYLLIUM COPPER PER ASTM-B-196 OR ASTM-B-197, ALLOY C17300, CONDITION H	GOLD PLATE PER MIL-G-45204
RETAINING RING	BERYLLIUM COPPER PER ASTM-B-194, ALLOY C17200, CONDITION H	N/A
GASKET O-RING	SILICONE RUBBER PER ZZ-R-765	N/A

DESIGNED FOR USE WITH .375 Micro-porous CABLE ENTRY DIAMETER MINIMUM	
CLAMP NUT	.385 [9.78]
BUSHING	.295 [7.49]
CONTACT	.118 [3.00]

ELECTRICAL	MECHANICAL	ENVIRONMENTAL
Nominal Impedance (Ohms) <u>50</u>	Interface Dimensions MIL-STD-348A, Fig. 313-1	Temperature Rating <u>-65 TO 105°C</u>
Frequency Range (GHz) <u>DC to 15.0</u>	Recommended Mating Torque <u>4 TO 65 IN-LBS</u>	Vibration MIL-STD-202, Method 204, Condition B
Volt Rating (VRMS MAX) @ Sea Level <u>500</u>	Mating Characteristics: Insertion (MAX Lbs) <u>5</u>	Shock MIL-STD-202, Method 213, Condition I
VSWR <u>1.22:1 MAX AT 8 GHz</u>	Withdrawal (MIN Oz) <u>N/A</u>	Thermal Shock MIL-STD-202, Method 107, Condition B, Except High Temp 115°C
Insertion Loss (dB MAX) <u>.06√F (GHz)</u>	Force to Engage and Disengage (In-Lbs MAX) <u>2.0</u>	Moisture Resistance MIL-STD-202, Method 106
RF Leakage (dB MIN) <u>-60</u>	Center Contact Captivation Axial (Lbs) <u>6.0</u>	Corrosion - MIL-STD-202, Method 101, Condition B, 5% salt spray
Corona, 70,000 Ft (VRMS MIN) <u>375</u>	Radial (In-Oz) <u>N/A</u>	
Dielectric Withstanding Voltage (VRMS MIN) @ Sea Level <u>1,500</u>	Cable Retention Axial Force (Lbs) <u>TBD</u>	
Contact Resistance (Milliohms MAX) Center Contact <u>1.5</u>	Torque (In-Oz) <u>TBD</u>	
Outer Contact <u>0.2</u>	Weight (Grams) <u>TBD</u>	
Cable to Housing <u>0.5</u>		
RF High Potential @ Sea Level (VRMS MIN @ 5 MHz) <u>1,000</u>		
I.R.(Megohms MIN) <u>1,000</u>		

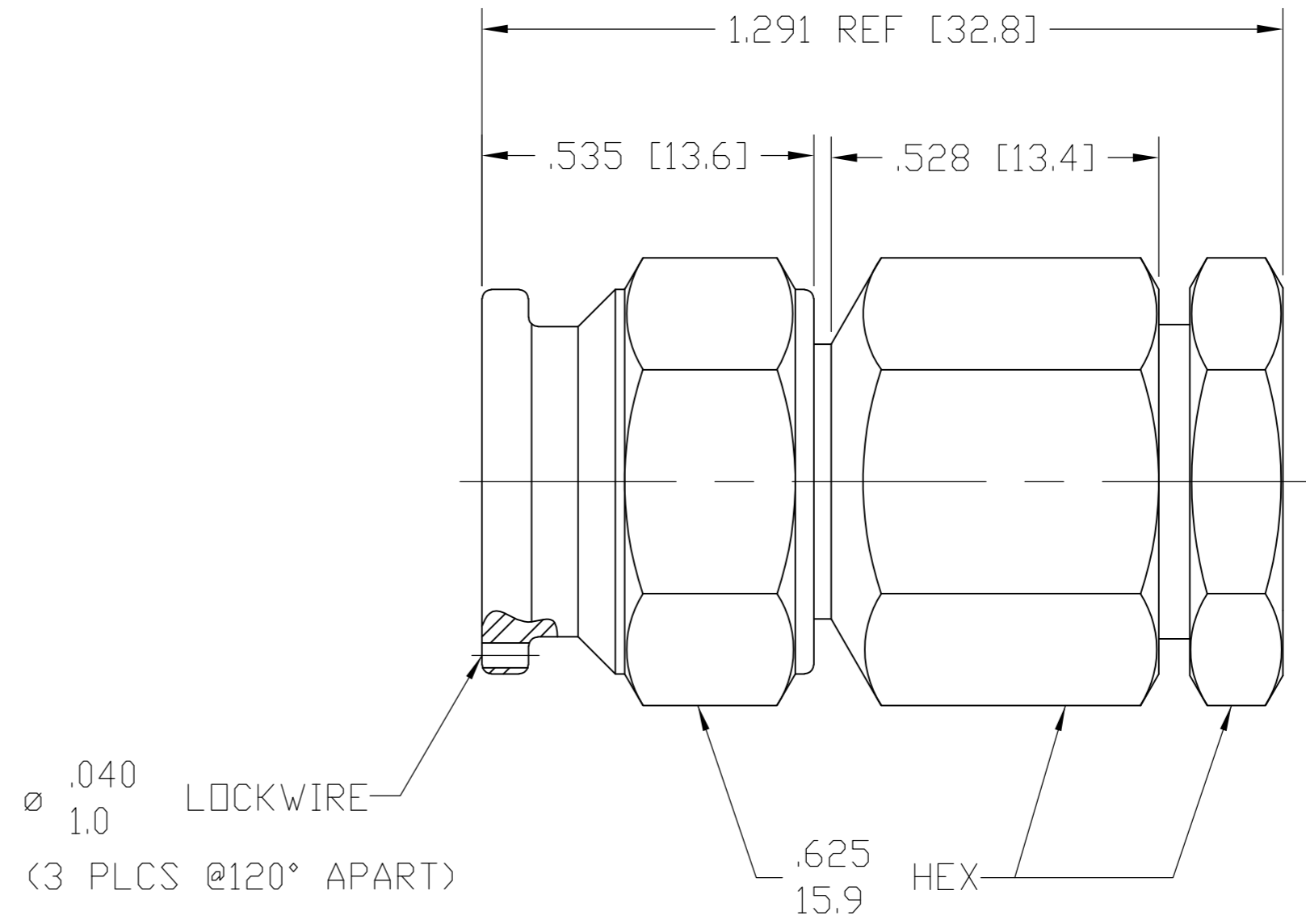

1060929-1  
PART NUMBER

THIS DRAWING IS A CONTROLLED DOCUMENT.		DWN C.C.THOMAS 01DEC2014	TE Connectivity	
DIMENSIONS: INCHES		CHK W.MOYER 12-1-14	NAME	
TOLERANCES UNLESS OTHERWISE SPECIFIED: 0 PLC ± - 1 PLC ± - 2 PLC ± - 3 PLC ± .005 4 PLC ± - ANGLES ± 1°		APVD W.MOYER 12-1-14	TNC STRAIGHT CABLE PLUG-CLAMP ATTACHMENT	
MATERIAL	FINISH	PRODUCT SPEC	SIZE A2	CAGE CODE 00779
-	-	APPLICATION SPEC	DRAWING NO 1060929-1	RESTRICTED TO
CUSTOMER DRAWING		WEIGHT	SCALE 4:1	SHEET 1 of 1
			REV B	