

FEATURES

44 V Supply Maximum Rating
 V_{SS} to V_{DD} Analog Signal Range
Single-/Dual-Supply Specifications
Wide Supply Ranges (10.8 V to 16.5 V)
Microprocessor Compatible (100 ns \overline{WR} Pulse)
Extended Plastic Temperature Range
 (–40°C to +85°C)
Low Leakage (20 pA typ)
Low Power Dissipation (28 mW max)
Available in 18-Lead DIP/SOIC and 20-Lead PLCC Packages
Superior Alternative to:
DG528
DG529

FUNCTIONAL BLOCK DIAGRAMS

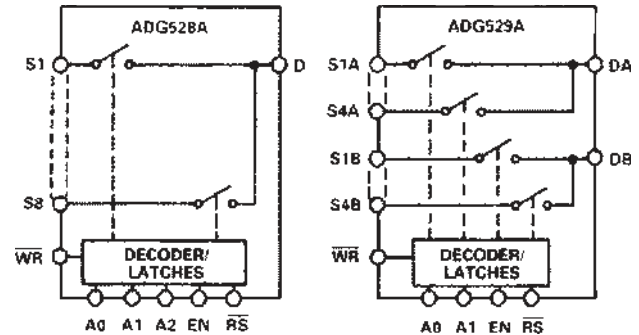

GENERAL DESCRIPTION

The ADG528A and ADG529A are CMOS monolithic analog multiplexers with eight channels and four dual channels, respectively. On-chip latches facilitate microprocessor interfacing. The ADG528A switches one of eight inputs to a common output, depending on the state of three binary addresses and an enable input. The ADG529A switches one of four differential inputs to a common differential output, depending on the state of two binary addresses and an enable input. Both devices have TTL and 5 V CMOS logic-compatible digital inputs.

The ADG528A and ADG529A are designed on an enhanced LC²MOS process, which gives an increased signal capability of V_{SS} to V_{DD} and enables operation over a wide range of supply voltages. The devices can comfortably operate anywhere in the 10.8 V to 16.5 V single- or dual-supply range. These multiplexers also feature high switching and low R_{ON} .

PRODUCT HIGHLIGHTS

- Single-/dual-supply specifications with a wide tolerance.**
 The devices are specified in the 10.8 V to 16.5 V range for both single- and dual-supplies.
- Easily Interfaced**
 The ADG528A and ADG529A can be easily interfaced with microprocessors. The \overline{WR} signal latches the state of the address control lines and the enable line. The \overline{RS} signal clears both the address and enable data in the latches resulting in no output (all switches off). \overline{RS} can be tied to the microprocessor reset pin.
- Extended Signal Range**
 The enhanced LC²MOS processing results in a high breakdown and an increased analog signal range of V_{SS} to V_{DD} .
- Break-Before-Make Switching**
 Switches are guaranteed break-before-make so that input signals are protected against momentary shorting.
- Low Leakage**
 Leakage currents in the range of 20 pA make these multiplexers suitable for high precision circuits.

REV. B

Information furnished by Analog Devices is believed to be accurate and reliable. However, no responsibility is assumed by Analog Devices for its use, nor for any infringements of patents or other rights of third parties that may result from its use. No license is granted by implication or otherwise under any patent or patent rights of Analog Devices. Trademarks and registered trademarks are the property of their respective owners.

ADG528A/ADG529A—SPECIFICATIONS

DUAL SUPPLY ($V_{DD} = +10.8\text{ V to }+16.5\text{ V}$, $V_{SS} = -10.8\text{ V to }-16.5\text{ V}$, unless otherwise noted.)

Parameter	ADG528A ADG529A K Version -40°C to		ADG528A ADG529A B Version -40°C to		ADG528A ADG529A T Version -55°C to		Units	Comments
	+25°C	+85°C	+25°C	+85°C	+25°C	+125°C		
ANALOG SWITCH								
Analogue Signal Range	V_{SS}	V_{SS}	V_{SS}	V_{SS}	V_{SS}	V_{SS}	V min	
	V_{DD}	V_{DD}	V_{DD}	V_{DD}	V_{DD}	V_{DD}	V max	
R_{ON}	280		280		280		Ω typ	$-10\text{ V} \leq V_S \leq +10\text{ V}$, $I_{DS} = 1\text{ mA}$; Test Circuit 1
	450	600	450	600	450	600	Ω max	
	300	400	300	400		400	Ω max	$V_{DD} = 15\text{ V} (\pm 10\%)$, $V_{SS} = -15\text{ V} (\pm 10\%)$
R_{ON} Drift	0.6		0.6		0.6		Ω max	$V_{DD} = 15\text{ V} (\pm 5\%)$, $V_{SS} = -15\text{ V} (\pm 5\%)$
R_{ON} Match	5		5		5		%/°C typ	$-10\text{ V} \leq V_S \leq +10\text{ V}$, $I_{DS} = 1\text{ mA}$
I_S (OFF), Off Input Leakage	0.02		0.02		0.02		nA typ	$V1 = \pm 10\text{ V}$, $V2 = \mp 10\text{ V}$; Test Circuit 2
	1	50	1	50	1	50	nA max	
I_D (OFF), Off Input Leakage	0.04		0.04		0.04		nA typ	$V1 = \pm 10\text{ V}$, $V2 = \mp 10\text{ V}$; Test Circuit 3
ADG528A	1	100	1	100	1	100	nA max	
ADG529A	1	50	1	50	1	50	nA max	
I_D (ON), On Channel Leakage	0.04		0.04		0.04		nA typ	$V1 = \pm 10\text{ V}$, $V2 = \mp 10\text{ V}$; Test Circuit 4
ADG528A	1	100	1	100	1	100	nA max	
ADG529A	1	50	1	50	1	50	nA max	
I_{DIFF} , Differential Off Output Leakage (ADG529A only)		25		25		25	nA max	$V1 = \pm 10\text{ V}$, $V2 = \mp 10\text{ V}$; Test Circuit 5
DIGITAL CONTROL								
V_{INH} , Input High Voltage		2.4		2.4		2.4	V min	
V_{INL} , Input Low Voltage		0.8		0.8		0.8	V max	
I_{INL} or I_{INH}		1		1		1	μA max	$V_{IN} = 0$ to V_{DD}
C_{IN} Digital Input Capacitance	8		8		8		pF max	
DYNAMIC CHARACTERISTICS ¹								
$t_{TRANSITION}$			200		200		ns typ	$V1 = \pm 10\text{ V}$, $V2 = \mp 10\text{ V}$; Test Circuit 6
	300	400	300	400	300	400	ns max	
t_{OPEN}			50		50		ns typ	Test Circuit 7
	25	10	25	10	25	10	ns min	
t_{ON} (EN, \overline{WR})			200		200		ns typ	Test Circuits 8 and 9
	300	400	300	400	300	400	ns max	
t_{OFF} (EN, \overline{RS})			200		200		ns typ	Test Circuits 8 and 10
	300	400	300	400	300	400	ns max	
t_W Write Pulse Width	100	120	100	120	100	130	ns min	See Figure 1
t_S Address, Enable Setup Time		100		100		100	ns min	See Figure 1
t_H Address, Enable Hold Time		10		10		10	ns min	See Figure 1
t_{RS} Reset Pulse Width		100		100		100	ns min	See Figure 2
OFF Isolation	68		68		68		dB typ	$V_{EN} = 0.8\text{ V}$, $R_L = 1\text{ k}\Omega$, $C_L = 15\text{ pF}$,
	50		50		50		dB min	$V_S = 7\text{ V rms}$, $f = 100\text{ kHz}$
C_S (OFF)	5		5		5		pF typ	$V_{EN} = 0.8\text{ V}$
C_D (OFF)								
ADG528A	22		22		22		pF typ	$V_{EN} = 0.8\text{ V}$
ADG529A	11		11		11		pF typ	
Q_{INJ} , Charge Injection	4		4		4		pC typ	$R_S = 0\text{ }\Omega$, $V_S = 0\text{ V}$; Test Circuit 11

Parameter	ADG528A ADG529A K Version -40°C to +25°C +85°C		ADG528A ADG529A B Version -40°C to +25°C +85°C		ADG528A ADG529A T Version -55°C to +25°C +125°C		Units	Comments
	POWER SUPPLY							
I _{DD}	0.6		0.6		0.6		mA typ	V _{IN} = V _{INL} or V _{INH}
		1.5		1.5		1.5	mA max	
I _{SS}	20		20		20		μA typ	V _{IN} = V _{INL} or V _{INH}
		0.2		0.2		0.2	mA max	
Power Dissipation	10		10		10		mW typ	
		2.8		2.8		2.8	mW max	

NOTE

¹Sample tested at +25°C to ensure compliance.

Specifications subject to change without notice.

SINGLE SUPPLY (V_{DD} = +10.8 V to +16.5 V, V_{SS} = GND = 0 V, unless otherwise noted.)

Parameter	ADG528A ADG529A K Version -40°C to +25°C +85°C		ADG528A ADG529A B Version -40°C to +25°C +85°C		ADG528A ADG529A T Version -55°C to +25°C +125°C		Units	Comments
	ANALOG SWITCH							
Analog Signal Range	GND	GND	GND	GND	GND	GND	V min	
	V _{DD}	V _{DD}	V _{DD}	V _{DD}	V _{DD}	V _{DD}	V max	
R _{ON}	500		500		500		Ω typ	GND ≤ V _S ≤ +10 V, I _{DS} = 0.5 mA; Test Circuit 1
	700	1000	700	1000	700	1000	Ω max	
R _{ON} Drift	0.6		0.6		0.6		%/°C typ	GND ≤ V _S ≤ +10 V, I _{DS} = 0.5 mA
R _{ON} Match	5		5		5		% typ	GND ≤ V _S ≤ +10 V, I _{DS} = 0.5 mA
I _S (OFF), Off Input Leakage	0.02		0.02		0.02		nA typ	V1 = +10 V/GND, V2 = GND/+10 V;
	1	50	1	50	1	50	nA max	Test Circuit 2
I _D (OFF), Off Input Leakage	0.04		0.04		0.04		nA typ	V1 = +10 V/GND, V2 = GND/+10 V;
ADG528A	1	100	1	100	1	100	nA max	Test Circuit 3
ADG529A	1	50	1	50	1	50	nA max	
I _D (ON), On Channel Leakage	0.04		0.04		0.04		nA typ	V1 = +10 V/GND, V2 = GND/+10 V;
ADG528A	1	100	1	100	1	100	nA max	Test Circuit 4
ADG529A	1	50	1	50	1	50	nA max	
I _{DIFF} , Differential Off Output Leakage (ADG529A only)		25		25		25	nA max	V1 = +10 V/GND, V2 = GND/+10 V; Test Circuit 5
DIGITAL CONTROL								
V _{INH} , Input High Voltage		2.4		2.4		2.4	V min	
V _{INL} , Input Low Voltage		0.8		0.8		0.8	V max	
I _{INL} or I _{INH}		1		1		1	μA max	V _{IN} = 0 to V _{DD}
C _{IN} , Digital Input Capacitance	8		8		8		pF max	
DYNAMIC CHARACTERISTICS ¹								
t _{TRANSITION}	300		300		300		ns typ	V1 = +10 V/GND, V2 = GND/+10 V; Test Circuit 6
	450	600	450	600	450	600	ns max	
t _{OPEN}	50		50		50		ns typ	Test Circuit 7
	25	10	25	10	25	10	ns min	
t _{ON} (EN, $\overline{\text{WR}}$)	250		250		250		ns typ	Test Circuits 8 and 9
	450	600	450	600	450	600	ns max	
t _{OFF} (EN, $\overline{\text{RS}}$)	250		250		250		ns typ	Test Circuits 8 and 10
	450	600	450	600	450	600	ns max	
t _W Write Pulse Width	100	120	100	120	100	130	ns min	See Figure 1

ADG528A/ADG529A

Parameter	ADG528A ADG529A K Version -40°C to +25°C +85°C	ADG528A ADG529A B Version -40°C to +25°C +85°C	ADG528A ADG529A T Version -55°C to +25°C +125°C	Units	Comments
DYNAMIC CHARACTERISTICS ¹ (Cont'd)					
t _S Address, Enable Setup Time	100	100	100	ns min	See Figure 1
t _H Address, Enable Hold Time	10	10	10	ns min	See Figure 1
t _{RS} Reset Pulse Width	100	100	100	ns min	See Figure 2
OFF Isolation	68	68	68	dB typ	V _{EN} = 0.8 V, R _L = 1 kΩ, C _L = 15 pF,
	50	50	50	dB min	V _S = 3.5 V rms, f = 100 kHz
C _S (OFF)	5	5	5	pF typ	V _{EN} = 0.8 V
C _D (OFF)					
ADG528A	22	22	22	pF typ	V _{EN} = 0.8 V
ADG529A	11	11	11	pF typ	
Q _{INJ} , Charge Injection	4	4	4	pC typ	R _S = 0 Ω, V _S = 0 V; Test Circuit 11
POWER SUPPLY					
I _{DD}	0.6	0.6	0.6	mA typ	V _{IN} = V _{INL} or V _{INH}
	1.5	1.5	1.5	mA max	
Power Dissipation	11	10	10	mW typ	
	25	25	25	mW max	

NOTE

¹Sample tested at +25°C to ensure compliance.

Specifications subject to change without notice.

PIN CONFIGURATIONS

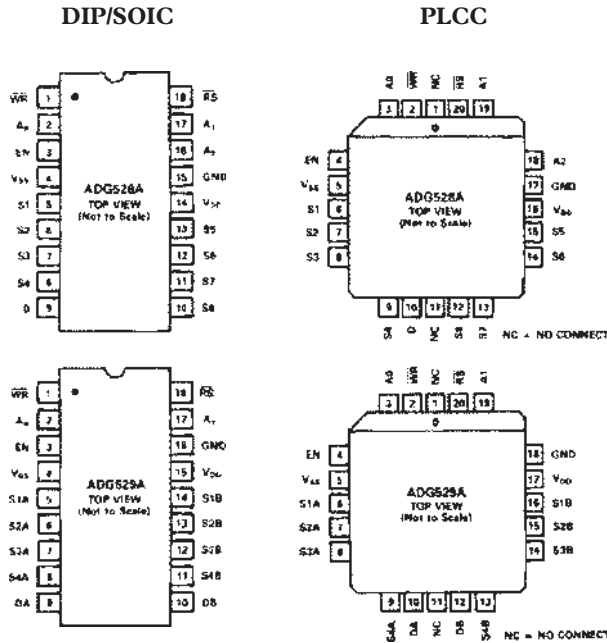

ABSOLUTE MAXIMUM RATINGS¹

(T_A = +25°C, unless otherwise noted)

V_{DD} to V_{SS} 44 V
 V_{DD} to GND 25 V
 V_{SS} to GND -25 V

Analog Inputs²

Voltage at S, D V_{SS} - 2 V to V_{DD} + 2 V or 20 mA, whichever Occurs First

Continuous Current, S or D 20 mA

Pulsed Current, S or D

1 ms duration, 10% Duty Cycle 40 mA

Digital Inputs¹

Voltage at A, EN, \overline{WR} , \overline{RS} V_{SS} - 4 V to V_{DD} + 4 V or 20 mA, whichever Occurs First

Power Dissipation (Any Package)

Up to +75°C 470 mW

Derates above +75°C 6 mW/°C

Operating Temperature

Commercial (K Version) -40°C to +85°C

Industrial (B Version) -40°C to +85°C

Extended (T Version) -55°C to +125°C

Storage Temperature Range -65°C to +150°C

Lead Temperature (Soldering, 10 sec) +300°C

NOTES

¹Stresses above those listed under “Absolute Maximum Ratings” may cause permanent damage to the device. This is a stress rating only and functional operation of the device at these or any other conditions above those indicated in the operational sections of this specification is not implied. Exposure to absolute maximum rating conditions for extended periods may affect device reliability.

²Overvoltage at A, EN, \overline{WR} , \overline{RS} , S or D will be clamped by diodes. Current should be limited to the maximum rating above.

ORDERING GUIDE

Model	Temperature Range	Package Description	Package Option ¹
ADG528AKN	-40°C to +85°C	PDIP	N-18
ADG528AKP	-40°C to +85°C	PLCC	P-20A
ADG528AKP-REEL	-40°C to +85°C	PLCC	P-20A
ADG528ABQ	-40°C to +85°C	CERDIP	Q-18
ADG528ATQ	-55°C to +125°C	CERDIP	Q-18
ADG528ABCHIPS		DIE	
ADG528ATCHIPS		DIE	
ADG529AKN	-40°C to +85°C	PDIP	N-18
ADG529AKP	-40°C to +85°C	PLCC	P-20A
ADG529AKRW	-40°C to +85°C	SOIC	RW-18
ADG529AKRW-REEL	-40°C to +85°C	SOIC	RW-18
ADG529AKRW-REEL7	-40°C to +85°C	SOIC	RW-18
ADG529ABQ	-40°C to +85°C	CERDIP	Q-18
ADG529ATQ	-55°C to +125°C	CERDIP	Q-18
ADG529ABCHIPS		DIE	
ADG529ATCHIPS		DIE	

NOTES

¹N = Plastic DIP; P = Plastic Leaded Chip Carrier (PLCC); Q = Cerdip; RW = SOIC.

CAUTION

ESD (electrostatic discharge) sensitive device. Electrostatic charges as high as 4000 V readily accumulate on the human body and test equipment and can discharge without detection. Although the ADG528A/ADG529A features proprietary ESD protection circuitry, permanent damage may occur on devices subjected to high energy electrostatic discharges. Therefore, proper ESD precautions are recommended to avoid performance degradation or loss of functionality.



ADG528A/ADG529A

TRUTH TABLES

A2	A1	A0	EN	\overline{WR}	\overline{RS}	ON SWITCH PAIR
X	X	X	X	✓	1	Retains Previous Switch Condition
X	X	X	X	X	0	NONE (Address and Enable Latches Cleared)
X	X	X	0	0	1	NONE
0	0	0	1	0	1	1
0	0	1	1	0	1	2
0	1	0	1	0	1	3
0	1	1	1	0	1	4
1	0	0	1	0	1	5
1	0	1	1	0	1	6
1	1	0	1	0	1	7
1	1	1	1	0	1	8

X = Don't Care

ADG528A

A1	A0	EN	\overline{WR}	\overline{RS}	ON SWITCH PAIR
X	X	X	✓	1	Retains Previous Switch Condition
X	X	X	X	0	NONE (Address and Enable Latches Cleared)
X	X	0	0	1	NONE
0	0	1	0	1	1
0	1	1	0	1	2
1	0	1	0	1	3
1	1	1	0	1	4

X = Don't Care

ADG529A

TIMING DIAGRAMS

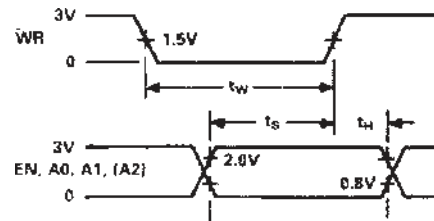

Figure 1.

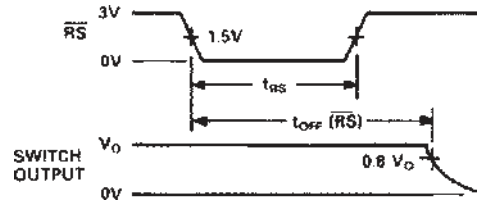

Figure 2.

Figure 1 shows the timing sequence for latching the switch address and enable inputs. The latches are level sensitive; therefore, while \overline{WR} is held low, the latches are transparent and the switches respond to the address and enable inputs. This input data is latched on the rising edge of \overline{WR} .

Figure 2 shows the Reset Pulse Width, t_{RS} , and Reset Turn-off Time, $t_{OFF}(\overline{RS})$.

Note: All digital input signals rise and fall times measured from 10% to 90% of 3 V. $t_R = t_F = 20$ ns.

Typical Performance Characteristics—ADG528A/ADG529A

The multiplexers are guaranteed functional with reduced single or dual supplies down to 4.5 V.

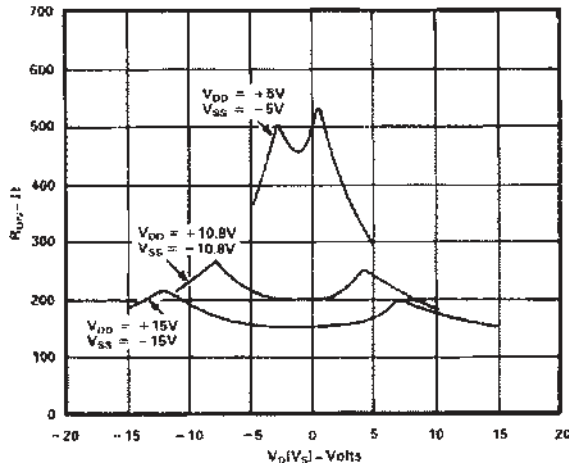

TPC 1. R_{ON} as a Function of $V_D(V_S)$: Dual Supply Voltage, $T_A = +25^\circ C$

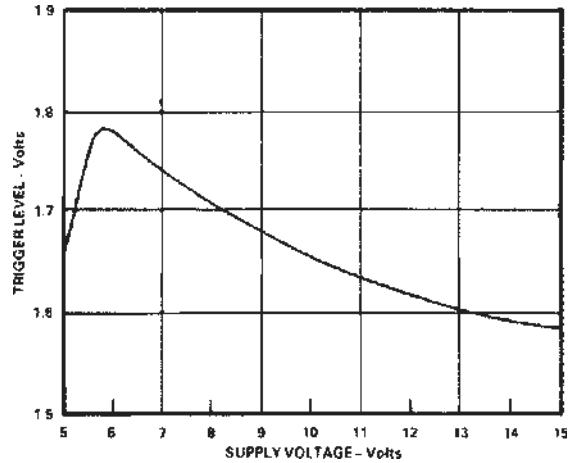

TPC 4. Trigger Levels vs. Power Supply Voltage, Dual or Single Supply, $T_A = +25^\circ C$

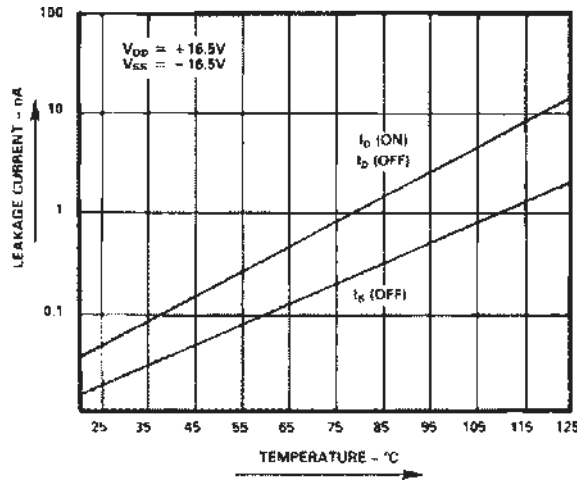

TPC 2. Leakage Current as a Function of Temperature (Note: Leakage Currents Reduce as the Supply Voltages Reduce)

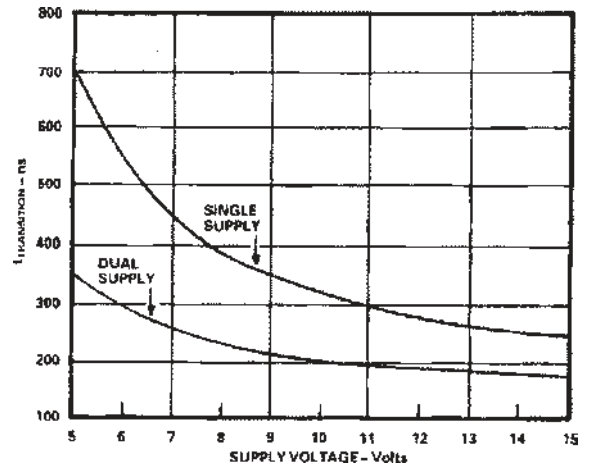

TPC 5. $t_{TRANSITION}$ vs. Supply Voltage: Dual and Single Supplies, $T_A = +25^\circ C$ (Note: For V_{DD} and $|V_{SS}| < 10 V$; $V_1 = V_{DD}/V_{SS}$, $V_2 = V_{SS}/V_{DD}$. See Test Circuit 6)

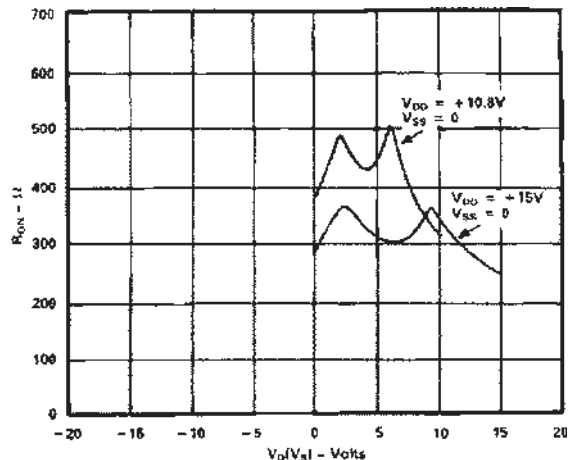

TPC 3. R_{ON} as a Function of $V_D(V_S)$: Single Supply Voltage, $T_A = +25^\circ C$

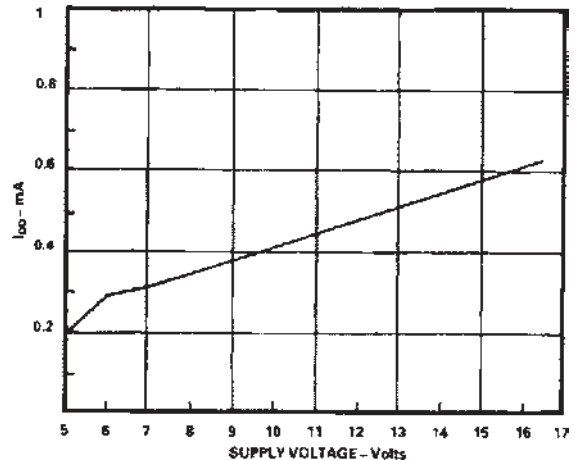

TPC 6. I_{DD} vs. Supply Voltage: Dual or Single Supply, $T_A = +25^\circ C$

ADG528A/ADG529A

Test Circuits

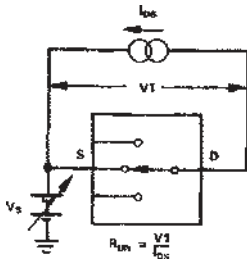

Test Circuit 1. R_{ON}

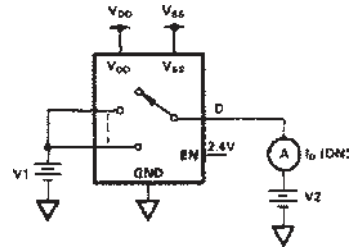

Test Circuit 4. I_D (ON)

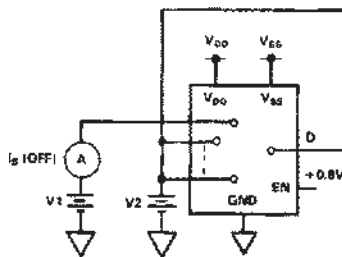

Test Circuit 2. I_S (OFF)

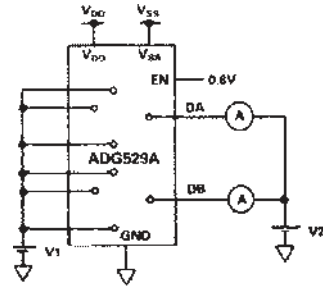

$$I_{DIFF} = I_{DA} (OFF) - I_{DB} (OFF)$$

Test Circuit 5. I_{DIFF}

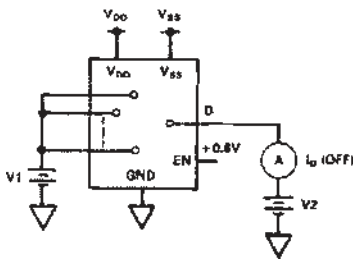

Test Circuit 3. I_D (OFF)

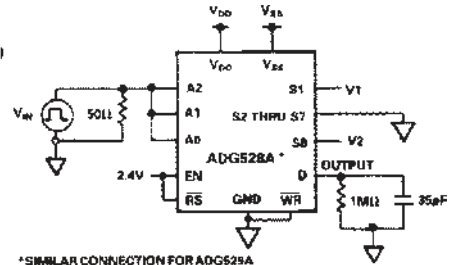
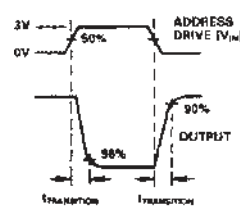

Test Circuit 6. Switching Time of Multiplexer, $t_{TRANSITION}$

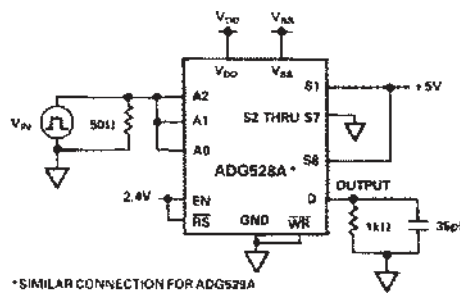
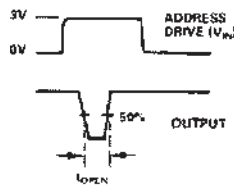

Test Circuit 7. Break-Before-Make Delay, t_{OPEN}

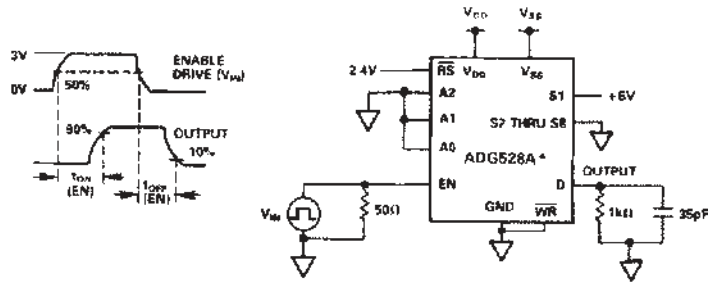

*SIMILAR CONNECTION FOR ADG529A

Test Circuit 8. Enable Delay, $t_{ON} (EN)$, $t_{OFF} (EN)$

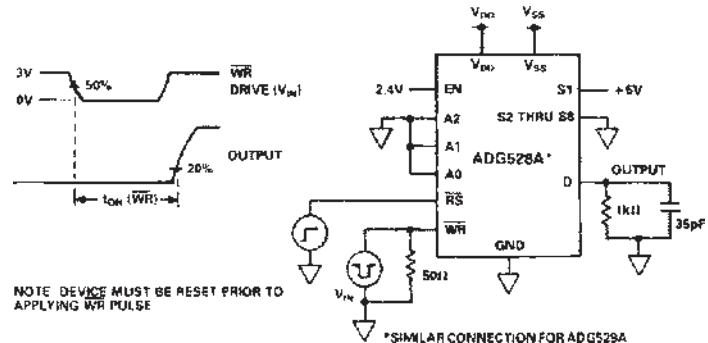

*SIMILAR CONNECTION FOR ADG529A

Test Circuit 9. Write Turn-On Time, $t_{ON} (\overline{WR})$

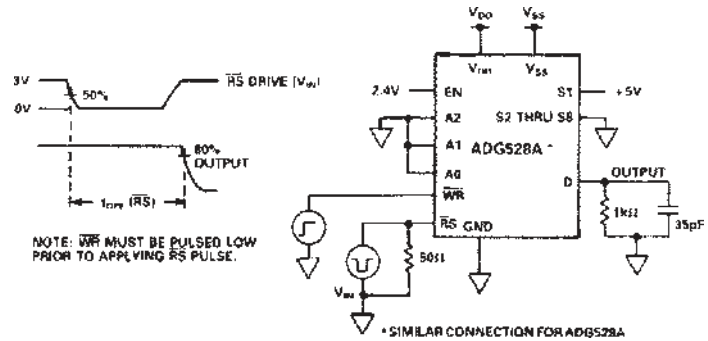

*SIMILAR CONNECTION FOR ADG529A

Test Circuit 10. Reset Turn-Off Time, $t_{OFF} (\overline{RS})$

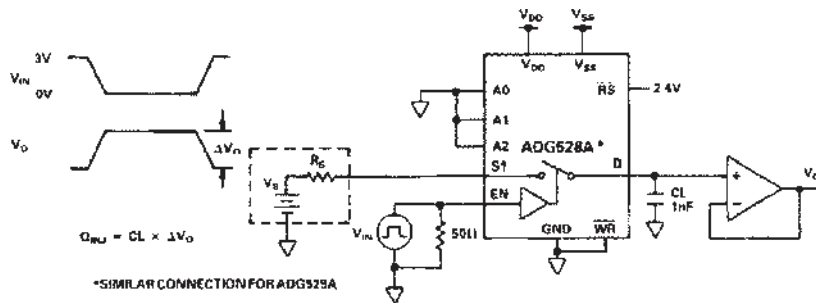

Test Circuit 11. Charge Injection

ADG528A/ADG529A

TERMINOLOGY

R_{ON}	Ohmic resistance between terminals D and S	$t_{OFF} (EN)$	Delay time between the 50% and 10% points of the digital input and switch "OFF" condition
$R_{ON} Match$	Difference between the R_{ON} of any two channels	$t_{TRANSITION}$	Delay time between the 50% and 90% points of the digital inputs and switch "ON" condition when switching from one address state to another.
$R_{ON} Drift$	Change in R_{ON} versus temperature	t_{OPEN}	"OFF" time measured between 50% points of both switches when switching from one address state to another
$I_S (OFF)$	Source terminal leakage current when the switch is off.	V_{INL}	Maximum input voltage for Logic "0"
$I_D (OFF)$	Drain terminal leakage current when the switch is off.	V_{INH}	Minimum input voltage for Logic "1"
$I_D (ON)$	Leakage current that flows from the closed switch into the body.	$I_{INL} (I_{INH})$	Input current of the digital input
$V_S (V_D)$	Analog voltage on terminal S or D	V_{DD}	Most positive voltage supply
$C_S (OFF)$	Channel input capacitance for "OFF" condition	V_{SS}	Most negative voltage supply
$C_D (OFF)$	Channel output capacitance for "OFF" condition	I_{DD}	Positive supply current
C_{IN}	Digital input capacitance	I_{SS}	Negative supply current
$t_{ON} (EN)$	Delay time between the 50% and 90% points of the digital input and switch "ON" condition.		

OUTLINE DIMENSIONS

18-Lead Plastic Dual In-Line Package [PDIP] (N-18)

Dimensions shown in inches and (millimeters)

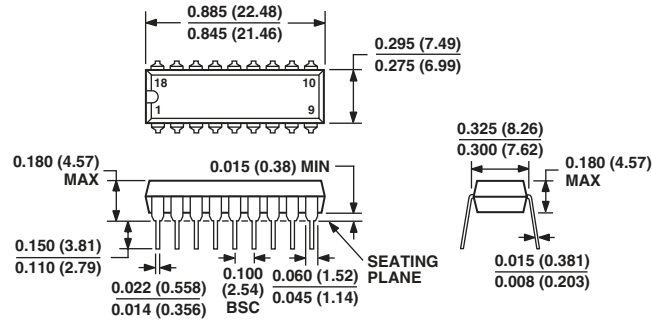

COMPLIANT TO JEDEC STANDARDS MO-095AD
CONTROLLING DIMENSIONS ARE IN INCHES; MILLIMETER DIMENSIONS
(IN PARENTHESES) ARE ROUNDED-OFF INCH EQUIVALENTS FOR
REFERENCE ONLY AND ARE NOT APPROPRIATE FOR USE IN DESIGN

20-Lead Plastic Leaded Chip Carrier [PLCC] (P-20A)

Dimensions shown in inches and (millimeters)

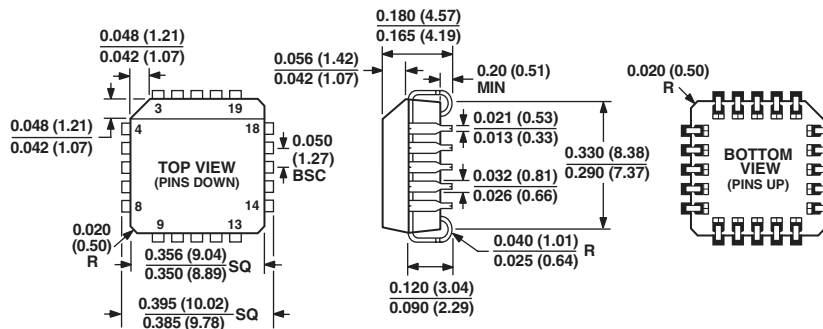

COMPLIANT TO JEDEC STANDARDS MO-047AA
CONTROLLING DIMENSIONS ARE IN INCHES; MILLIMETER DIMENSIONS
(IN PARENTHESES) ARE ROUNDED-OFF INCH EQUIVALENTS FOR
REFERENCE ONLY AND ARE NOT APPROPRIATE FOR USE IN DESIGN

OUTLINE DIMENSIONS

18-Lead Ceramic Dual In-Line Package [CERDIP] (Q-18)

Dimensions shown in inches and (millimeters)

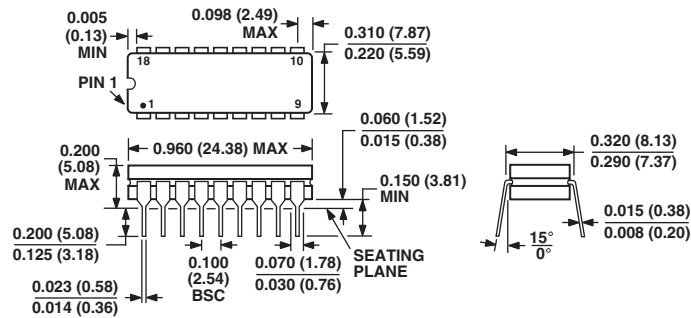

CONTROLLING DIMENSIONS ARE IN INCHES; MILLIMETER DIMENSIONS (IN PARENTHESES) ARE ROUNDED-OFF INCH EQUIVALENTS FOR REFERENCE ONLY AND ARE NOT APPROPRIATE FOR USE IN DESIGN

18-Lead Standard Small Outline Package [SOIC] Wide Body (RW-18)

Dimensions shown in millimeters and (inches)

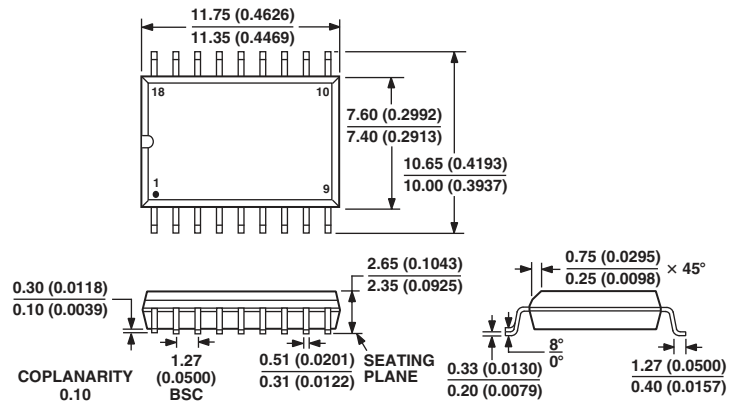

COMPLIANT TO JEDEC STANDARDS MS-013AB
CONTROLLING DIMENSIONS ARE IN MILLIMETERS; INCH DIMENSIONS (IN PARENTHESES) ARE ROUNDED-OFF MILLIMETER EQUIVALENTS FOR REFERENCE ONLY AND ARE NOT APPROPRIATE FOR USE IN DESIGN

ADG528A/ADG529A

Revision History

Location	Page
10/04—Data Sheet Changed from Rev. A to Rev. B	
Deleted 20-Lead LCC package	Universal
Changes to FEATURES	5
Changes to ORDERING GUIDE	6
SOIC added to DIP PIN CONFIGURATION	5
Updated OUTLINE DIMENSIONS	9

C03337-0-10/04(B)