

MPU-3300
Product Specification
Revision 1.1

CONTENTS

1	REVISION HISTORY	4
2	PURPOSE AND SCOPE	4
3	PRODUCT OVERVIEW	6
3.1	MPU-3300 OVERVIEW	6
4	APPLICATIONS.....	7
5	FEATURES	8
5.1	GYROSCOPE FEATURES.....	8
5.2	ADDITIONAL FEATURES	8
5.3	CLOCKING	8
6	ELECTRICAL CHARACTERISTICS.....	9
6.1	GYROSCOPE SPECIFICATIONS	9
6.2	ELECTRICAL AND OTHER COMMON SPECIFICATIONS.....	10
6.3	ELECTRICAL SPECIFICATIONS, CONTINUED	11
6.4	ELECTRICAL SPECIFICATIONS, CONTINUED	12
6.5	ELECTRICAL SPECIFICATIONS, CONTINUED	13
6.6	I ² C TIMING CHARACTERIZATION.....	14
6.7	SPI TIMING CHARACTERIZATION.....	15
6.8	ABSOLUTE MAXIMUM RATINGS	16
7	APPLICATIONS INFORMATION	17
7.1	PIN OUT AND SIGNAL DESCRIPTION	17
7.2	TYPICAL OPERATING CIRCUIT.....	18
7.3	BILL OF MATERIALS FOR EXTERNAL COMPONENTS	18
7.4	BLOCK DIAGRAM	19
7.5	OVERVIEW	19
7.6	THREE-AXIS MEMS GYROSCOPE WITH 16-BIT ADCs AND SIGNAL CONDITIONING.....	19
7.7	PRIMARY I ² C AND SPI SERIAL COMMUNICATIONS INTERFACES	20
7.8	AUXILIARY I ² C SERIAL INTERFACE	21
7.9	SELF-TEST.....	22
7.10	BIAS INSTABILITY	22
	Z-AXIS GYROSCOPE – EXAMPLE ALLAN VARIANCE PLOT	23
7.11	MPU-3300 USING SPI INTERFACE.....	23
7.12	INTERNAL CLOCK GENERATION	24
7.13	SENSOR DATA REGISTERS.....	25

7.14	FIFO	25
7.15	INTERRUPTS	26
7.16	DIGITAL-OUTPUT TEMPERATURE SENSOR	26
7.17	BIAS AND LDO	26
7.18	CHARGE PUMP	26
8	PROGRAMMABLE INTERRUPTS.....	27
9	DIGITAL INTERFACE	28
9.1	I ² C AND SPI SERIAL INTERFACES	28
9.2	I ² C INTERFACE	28
9.3	I ² C COMMUNICATIONS PROTOCOL.....	28
9.4	I ² C TERMS	31
9.5	SPI INTERFACE	32
10	ASSEMBLY	33
10.1	ORIENTATION OF AXES	33
10.2	PACKAGE DIMENSIONS	34
10.3	PCB DESIGN GUIDELINES.....	35
10.4	ASSEMBLY PRECAUTIONS	36
10.5	STORAGE SPECIFICATIONS.....	39
10.6	PACKAGE MARKING SPECIFICATION.....	39
10.7	TAPE & REEL SPECIFICATION.....	40
10.8	LABEL	41
10.9	PACKAGING.....	42
10.10	REPRESENTATIVE SHIPPING CARTON LABEL.....	43
11	RELIABILITY	44
11.1	QUALIFICATION TEST POLICY	44
11.2	QUALIFICATION TEST PLAN	44
12	ENVIRONMENTAL COMPLIANCE.....	45

1 Revision History

Revision Date	Revision	Description
5/31/2012	1.0	Initial Release
7/23/2012	1.1	Removed watermarks.

2 Purpose and Scope

This product specification provides advanced information regarding the electrical specification and design related information for the MPU-3300™ MotionTracking™ devices.

Electrical characteristics are based upon design analysis and simulation results only. Specifications are subject to change without notice. Final specifications will be updated based upon characterization of production silicon. For references to register map and descriptions of individual registers, please refer to the MPU-3300 Register Map and Register Descriptions document.

3 Product Overview

3.1 MPU-3300 Overview

The MPU-3300 is the world's first integrated 3-axis gyroscope for Industrial applications. The MPU-3300 features three 16-bit analog-to-digital converters (ADCs) for digitizing the gyroscope outputs. For precision tracking of motion, the parts feature a user-programmable gyroscope full-scale range of ± 225 and $\pm 450^\circ/\text{sec}$ (dps).

An on-chip 1024 Byte FIFO buffer helps lower system power consumption by allowing the system processor to read the sensor data in bursts and then enter a low-power mode as the MPU collects more data. Communication with all registers of the device is performed using either I²C at 400kHz or SPI at 1MHz. For applications requiring faster communications, the sensor and interrupt registers may be read using SPI at 20MHz. Additional features include an embedded temperature sensor and an on-chip oscillator with $\pm 1\%$ variation over the operating temperature range.

By leveraging its patented and volume-proven Nasiri-Fabrication platform, which integrates MEMS wafers with companion CMOS electronics through wafer-level bonding, InvenSense has driven the MPU-3300 package size down to a revolutionary footprint of 4x4x0.9mm (QFN), while providing the highest performance, lowest noise, and the lowest cost semiconductor packaging required for industrial electronic devices. The part features a robust 10,000g shock tolerance, and has programmable low-pass filters for the gyroscopes, and the on-chip temperature sensor.

For power supply flexibility, the MPU-3300 operates from VDD power supply voltage range of 2.375V-3.46V.

4 Applications

- Attitude Heading Reference Systems (AHRS)
 - Aerospace
 - Robotics
- Navigation Systems
 - Industrial vehicles
 - Aircraft
 - Ships
- Platform and Antenna Stabilization
- Precision Robotics
- Inventory Control Systems
- Survey Instruments
- Factory Equipment
- Industrial Power Tools
- Unmanned Aerial Vehicles (UAVs)
- Precision Agriculture Machinery
- Guidance and Steering Applications
- Construction Equipment

5 Features

5.1 Gyroscope Features

The triple-axis MEMS gyroscope in the MPU-3300 includes a wide range of features:

- Digital-output X-, Y-, and Z-Axis angular rate sensors (gyroscopes) with a user-programmable full-scale range of ± 225 , and $\pm 450^\circ/\text{sec}$
- Integrated 16-bit ADCs enable simultaneous sampling of gyros
- Enhanced bias and sensitivity temperature stability reduces the need for user calibration
- Improved low-frequency noise performance
- Digitally-programmable low-pass filter
- Bias Instability: $15^\circ/\text{hour}$ on each axis
- Gyroscope operating current: 3.6mA
- Standby current: $10\mu\text{A}$
- Factory calibrated sensitivity scale factor
- User self-test

5.2 Additional Features

The MPU-3300 includes the following additional features:

- VDD supply voltage range of 2.375V-3.46V
- Smallest and thinnest QFN package for industrial applications: 4x4x0.9mm
- 1024 byte FIFO buffer reduces power consumption by allowing host processor to read the data in bursts and then go into a low-power mode as the MPU collects more data
- Digital-output temperature sensor
- User-programmable digital filters for gyroscope and temp sensor
- 10,000 *g* shock tolerant
- 400kHz Fast Mode I²C for communicating with all registers
- 1MHz SPI serial interface for communicating with all registers
- 20MHz SPI serial interface for reading sensor and interrupt registers
- MEMS structure hermetically sealed and bonded at wafer level
- RoHS and Green compliant

5.3 Clocking

- On-chip timing generator $\pm 1\%$ frequency variation over full temperature range
- Optional external clock inputs of 32.768kHz or 19.2MHz

6 Electrical Characteristics

6.1 Gyroscope Specifications

 Typical Operating Circuit of Section 7.2, VDD = 2.375V-3.46V, T_A = 25°C

PARAMETER	CONDITIONS	MIN	TYP	MAX	UNITS	NOTES
GYROSCOPE SENSITIVITY						
Full-Scale Range	FS_SEL=0		±225		°/s	
	FS_SEL=1		±450		°/s	
Gyroscope ADC Word Length			16		bits	
Sensitivity Scale Factor	FS_SEL=0		145.6		LSB/(°/s)	
	FS_SEL=1		72.8		LSB/(°/s)	
Sensitivity Scale Factor Tolerance	25°C	-3		+3	%	
Sensitivity Scale Factor Variation Over Temperature	-40°C to +105°C		±2		%	
Nonlinearity	Best fit straight line; 25°C		0.2		%	
Cross-Axis Sensitivity			±2		%	
GYROSCOPE ZERO-RATE OUTPUT (ZRO)						
Initial ZRO Tolerance	25°C		±20		°/s	
ZRO Variation Over Temperature	-40°C to +105°C		±20		°/s	
Power-Supply Sensitivity (1 – 10Hz)	Sine wave, 100mVpp; VDD=2.5V		0.2		°/s	
Power-Supply Sensitivity (10 – 250Hz)	Sine wave, 100mVpp; VDD=2.5V		0.2		°/s	
Power-Supply Sensitivity (250Hz – 100kHz)	Sine wave, 100mVpp; VDD=2.5V		4		°/s	
Linear Acceleration Sensitivity	Static		0.1		°/s/g	
SELF-TEST RESPONSE	Change from factory trim	-14		14	%	1
GYROSCOPE NOISE PERFORMANCE	FS_SEL=0					
Total RMS Noise	DLPFCFG=2 (100Hz)		0.05		°/s-rms	
Low-frequency RMS noise	Bandwidth 1Hz to 10Hz		0.033		°/s-rms	
Rate Noise Spectral Density	At 10Hz		0.005		°/s/√Hz	
GYROSCOPE MECHANICAL FREQUENCIES						
X-Axis		30	33	36	kHz	
Y-Axis		27	30	33	kHz	
Z-Axis		24	27	30	kHz	
LOW PASS FILTER RESPONSE	Programmable Range	5		256	Hz	
OUTPUT DATA RATE	Programmable	4		8,000	Hz	
GYROSCOPE START-UP TIME	DLPFCFG=0					
ZRO Settling	to ±1°/s of Final		30		ms	

 1. Please refer to the following document for further information on Self-Test: *MPU-3300 Register Map and Descriptions*

6.2 Electrical and Other Common Specifications

 Typical Operating Circuit of Section 7.2, VDD = 2.375V-3.46V, T_A = 25°C

PARAMETER	CONDITIONS	MIN	TYP	MAX	Units	Notes
TEMPERATURE SENSOR						
Range			-40 to +105		°C	
Sensitivity	Untrimmed		340		LSB/°C	
Temperature Offset	35°C		-521		LSB	
Linearity	Best fit straight line (-40°C to +105°C)		±1		°C	
VDD POWER SUPPLY						
Operating Voltages		2.375		3.46	V	
Normal Operating Current	Gyroscope		3.6		mA	
Full-Chip Idle Mode Supply Current			10		µA	
Power Supply Ramp Rate	Monotonic ramp. Ramp rate is 10% to 90% of the final value			100	ms	
START-UP TIME FOR REGISTER READ/WRITE						
			20	100	ms	
TEMPERATURE RANGE						
Specified Temperature Range	Performance parameters are not applicable beyond Specified Temperature Range	-40		+105	°C	

6.3 Electrical Specifications, Continued

 Typical Operating Circuit of Section 7.2, VDD = 2.375V-3.46V, T_A = 25°C

PARAMETER	CONDITIONS	MIN	TYP	MAX	Units	Notes
SERIAL INTERFACE						
SPI Operating Frequency, All Registers Read/Write	Low Speed Characterization		100 ±10%		kHz	
	High Speed Characterization		1 ±10%		MHz	
SPI Operating Frequency, Sensor and Interrupt Registers Read Only			20 ±10%		MHz	
I ² C Operating Frequency	All registers, Fast-mode			400	kHz	
	All registers, Standard-mode			100	kHz	
I²C ADDRESS	AD0 = 0		1101000			
	AD0 = 1		1101001			
DIGITAL INPUTS (SDI/SDA, AD0, SCLK/SCL, FSYNC, /CS, CLKIN)						
V _{IH} , High Level Input Voltage		0.7*VDD			V	
V _{IL} , Low Level Input Voltage				0.3*VDD	V	
C _i , Input Capacitance			< 5		pF	
DIGITAL OUTPUT (SDO, INT)						
V _{OH} , High Level Output Voltage	R _{LOAD} =1MΩ	0.9*VDD			V	
V _{OL1} , LOW-Level Output Voltage	R _{LOAD} =1MΩ			0.1*VDD	V	
V _{OLINT1} , INT Low-Level Output Voltage	OPEN=1, 0.3mA sink Current			0.1	V	
Output Leakage Current	OPEN=1		100		nA	
t _{INT} , INT Pulse Width	LATCH_INT_EN=0		50		μs	
DIGITAL OUTPUT (CLKOUT)						
V _{OH} , High Level Output Voltage	R _{LOAD} =1MΩ	0.9*VDD			V	
V _{OL1} , LOW-Level Output Voltage	R _{LOAD} =1MΩ			0.1*VDD	V	

6.4 Electrical Specifications, Continued

Typical Operating Circuit of Section 7.2, VDD = 2.375V-3.46V, TA = 25°C

Parameters	Conditions	Typical	Units	Notes
Primary I²C I/O (SCL, SDA)				
V _{IL} , LOW Level Input Voltage		-0.5V to 0.3*VDD	V	
V _{IH} , HIGH-Level Input Voltage		0.7*VDD to VDD + 0.5V	V	
V _{hys} , Hysteresis		0.1*VDD	V	
V _{OL1} , LOW-Level Output Voltage	3mA sink current	0 to 0.4	V	
I _{OL} , LOW-Level Output Current	V _{OL} = 0.4V	3	mA	
	V _{OL} = 0.6V	5	mA	
Output Leakage Current		100	nA	
t _{of} , Output Fall Time from V _{IHmax} to V _{ILmax}	C _b bus capacitance in pF	20+0.1C _b to 250	ns	
C _I , Capacitance for Each I/O pin		< 10	pF	
Auxiliary I²C I/O (AUX_CL, AUX_DA)				
V _{IL} , LOW-Level Input Voltage		-0.5 to 0.3*VDD	V	
V _{IH} , HIGH-Level Input Voltage		0.7*VDD to VDD+0.5V	V	
V _{hys} , Hysteresis		0.1*VDD	V	
V _{OL1} , LOW-Level Output Voltage	1mA sink current	0 to 0.4	V	
I _{OL} , LOW-Level Output Current	V _{OL} = 0.4V	1	mA	
	V _{OL} = 0.6V	1	mA	
Output Leakage Current		100	nA	
t _{of} , Output Fall Time from V _{IHmax} to V _{ILmax}	C _b bus cap. in pF	20+0.1C _b to 250	ns	
C _I , Capacitance for Each I/O pin		< 10	pF	

6.5 Electrical Specifications, Continued

 Typical Operating Circuit of Section 7.2, VDD = 2.375V-3.46V, T_A = 25°C

Parameters	Conditions	Min	Typical	Max	Units	Notes
INTERNAL CLOCK SOURCE						
Gyroscope Sample Rate, Fast	CLK_SEL=0,1,2,3 DLPFCFG=0 SAMPLERATEDIV = 0		8		kHz	
Gyroscope Sample Rate, Slow	DLPFCFG=1,2,3,4,5, or 6 SAMPLERATEDIV = 0		1		kHz	
Reference Clock Output	CLKOUTEN = 1		1.024		MHz	
Clock Frequency Initial Tolerance	CLK_SEL=0, 25°C	-5		+5	%	
	CLK_SEL=1,2,3; 25°C	-1		+1	%	
Frequency Variation over Temperature	CLK_SEL=0		-15 to +10		%	
	CLK_SEL=1,2,3		±1		%	
PLL Settling Time	CLK_SEL=1,2,3		1	10	ms	
EXTERNAL 32.768kHz CLOCK						
External Clock Frequency	CLK_SEL=4		32.768		kHz	
External Clock Allowable Jitter	Cycle-to-cycle rms		1 to 2		µs	
Gyroscope Sample Rate, Fast	DLPFCFG=0 SAMPLERATEDIV = 0		8.192		kHz	
Gyroscope Sample Rate, Slow	DLPFCFG=1,2,3,4,5, or 6 SAMPLERATEDIV = 0		1.024		kHz	
Reference Clock Output	CLKOUTEN = 1		1.0486		MHz	
PLL Settling Time			1	10	ms	
EXTERNAL 19.2MHz CLOCK						
External Clock Frequency	CLK_SEL=5		19.2		MHz	
Gyroscope Sample Rate	Full programmable range	3.9		8000	Hz	
Gyroscope Sample Rate, Fast Mode	DLPFCFG=0 SAMPLERATEDIV = 0		8		kHz	
Gyroscope Sample Rate, Slow Mode	DLPFCFG=1,2,3,4,5, or 6 SAMPLERATEDIV = 0		1		kHz	
Reference Clock Output	CLKOUTEN = 1		1.024		MHz	
PLL Settling Time			1	10	ms	

6.6 I²C Timing Characterization

Typical Operating Circuit of Section 7.2, VDD = 2.375V-3.46V, T_A = 25°C

Parameters	Conditions	Min	Typical	Max	Units	Notes
I²C TIMING						
I²C FAST-MODE						
f _{SCL} , SCL Clock Frequency				400	kHz	
t _{HD,STA} , (Repeated) START Condition Hold Time		0.6			µs	
t _{LOW} , SCL Low Period		1.3			µs	
t _{HIGH} , SCL High Period		0.6			µs	
t _{SU,STA} , Repeated START Condition Setup Time		0.6			µs	
t _{HD,DAT} , SDA Data Hold Time		0			µs	
t _{SU,DAT} , SDA Data Setup Time		100			ns	
t _r , SDA and SCL Rise Time	C _b bus cap. from 10 to 400pF	20+0.1C _b		300	ns	
t _f , SDA and SCL Fall Time	C _b bus cap. from 10 to 400pF	20+0.1C _b		300	ns	
t _{SU,STO} , STOP Condition Setup Time		0.6			µs	
t _{BUF} , Bus Free Time Between STOP and START Condition		1.3			µs	
C _b , Capacitive Load for each Bus Line			< 400		pF	
t _{VD,DAT} , Data Valid Time				0.9	µs	
t _{VD,ACK} , Data Valid Acknowledge Time				0.9	µs	

Note: Timing Characteristics apply to both Primary and Auxiliary I²C Bus

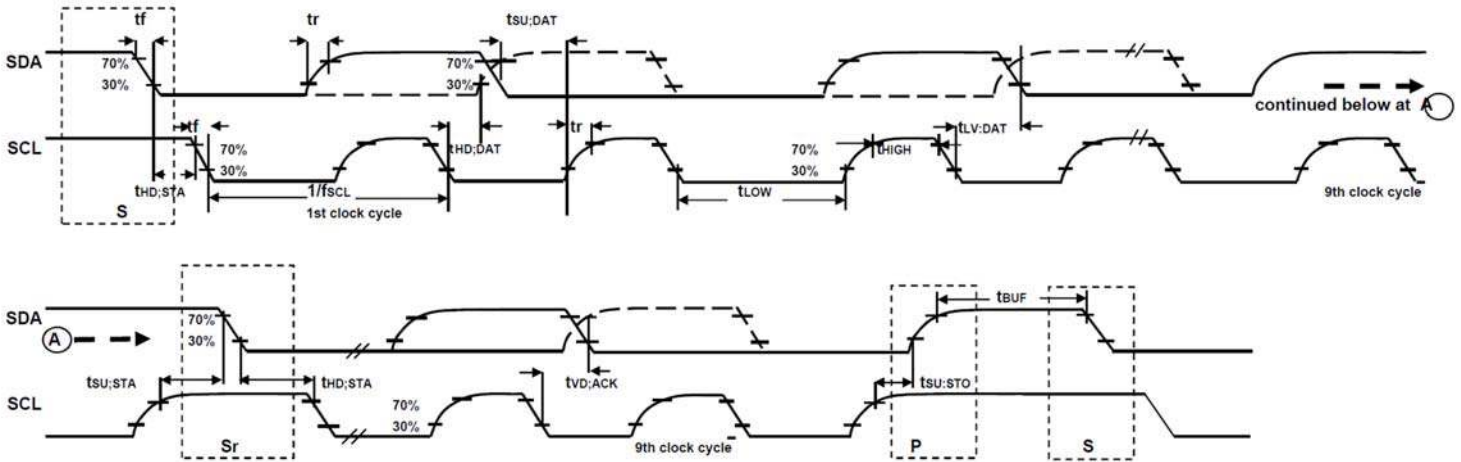

I²C Bus Timing Diagram

6.7 SPI Timing Characterization

Typical Operating Circuit of Section 7.2, VDD = 2.375V-3.46V, T_A = 25°C, unless otherwise noted.

Parameters	Conditions	Min	Typical	Max	Units	Notes
SPI TIMING						
f _{SCLK} , SCLK Clock Frequency				1	MHz	
t _{LOW} , SCLK Low Period		400			ns	
t _{HIGH} , SCLK High Period		400			ns	
t _{SU,CS} , CS Setup Time		8			ns	
t _{HD,CS} , CS Hold Time		500			ns	
t _{SU,SDI} , SDI Setup Time		11			ns	
t _{HD,SDI} , SDI Hold Time		7			ns	
t _{VD,SDO} , SDO Valid Time	C _{load} = 20pF			100	ns	
t _{HD,SDO} , SDO Hold Time	C _{load} = 20pF	4			ns	
t _{DIS,SDO} , SDO Output Disable Time				10	ns	

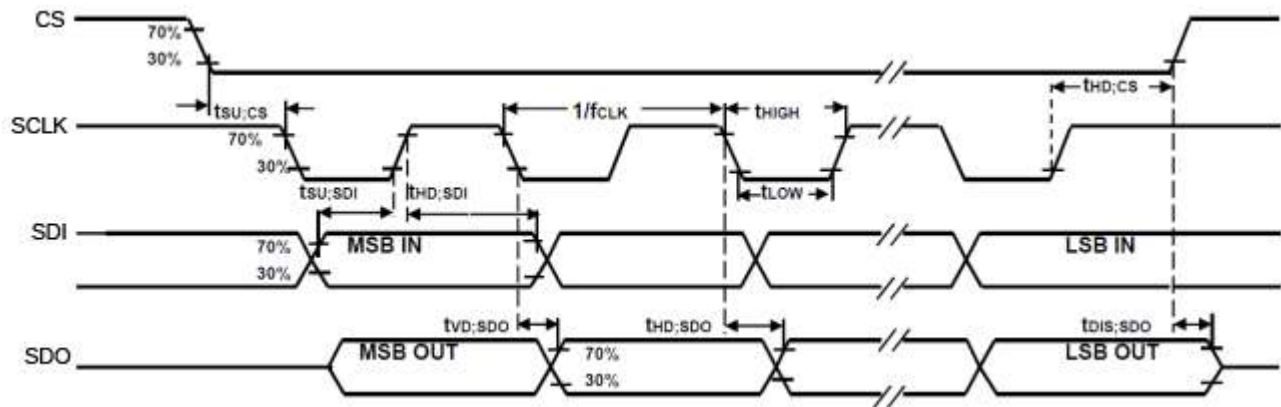

SPI Bus Timing Diagram

6.8 Absolute Maximum Ratings

Stress above those listed as “Absolute Maximum Ratings” may cause permanent damage to the device. These are stress ratings only and functional operation of the device at these conditions is not implied. Exposure to the absolute maximum ratings conditions for extended periods may affect device reliability.

Parameter	Rating
Supply Voltage, VDD	-0.5V to +6V
REGOUT	-0.5V to 2V
Input Voltage Level (CLKIN, AUX_DA, AD0, FSYNC, INT, SCL, SDA)	-0.5V to VDD + 0.5V
CPOUT (2.5V ≤ VDD ≤ 3.6V)	-0.5V to 30V
Acceleration (Any Axis, unpowered)	10,000g for 0.2ms
Operating Temperature Range	-40°C to +125°C
Storage Temperature Range	-65°C to +150°C
Electrostatic Discharge (ESD) Protection	2kV (HBM); 200V (MM)
Latch-up	JEDEC Class II (2), 125°C ±60mA

7 Applications Information

7.1 Pin Out and Signal Description

Pin Number	Pin Name	Pin Description
1	CLKIN	Optional external reference clock input. Connect to GND if unused.
6	AUX_DA	I ² C master serial data, for connecting to external sensors
7	AUX_CL	I ² C master serial clock, for connecting to external sensors
8	/CS	SPI chip select (0=SPI mode)
9	AD0 / SDO	I ² C Slave Address LSB (AD0); SPI serial data output (SDO)
10	REGOUT	Regulator filter capacitor connection
11	FSYNC	Frame synchronization digital input. Connect to GND if unused.
12	INT	Interrupt digital output (totem pole or open-drain)
13	VDD	Power supply voltage and Digital I/O supply voltage
18	GND	Power supply ground
19, 21	RESV	Reserved. Do not connect.
20	CPOUT	Charge pump capacitor connection
22	CLKOUT	System clock output
23	SCL / SCLK	I ² C serial clock (SCL); SPI serial clock (SCLK)
24	SDA / SDI	I ² C serial data (SDA); SPI serial data input (SDI)
2, 3, 4, 5, 14, 15, 16, 17	NC	Not internally connected. May be used for PCB trace routing.

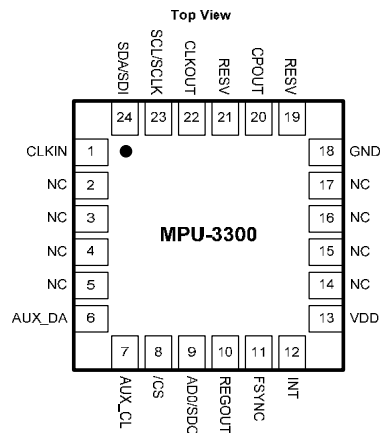

QFN Package
24-pin, 4mm x 4mm x 0.9mm

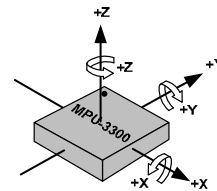

Orientation of Axes of Sensitivity and Polarity of Rotation

7.2 Typical Operating Circuit

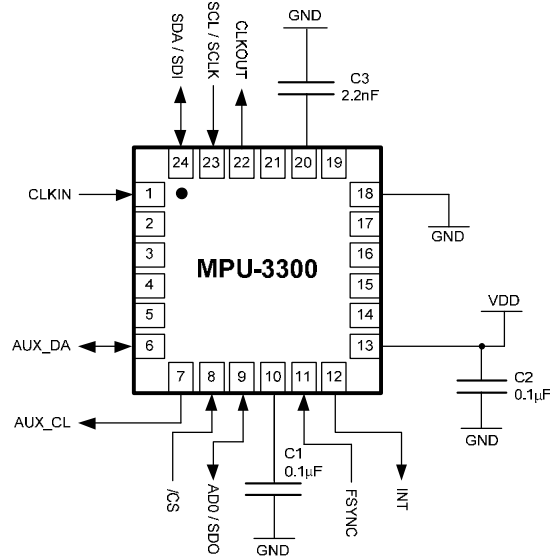

Typical Operating Circuit

7.3 Bill of Materials for External Components

Component	Label	Specification	Quantity
Regulator Filter Capacitor (Pin 10)	C1	Ceramic, X7R, 0.1µF ±10%, 2V	1
VDD Bypass Capacitor (Pin 13)	C2	Ceramic, X7R, 0.1µF ±10%, 4V	1
Charge Pump Capacitor (Pin 20)	C3	Ceramic, X7R, 2.2nF ±10%, 50V	1

7.4 Block Diagram

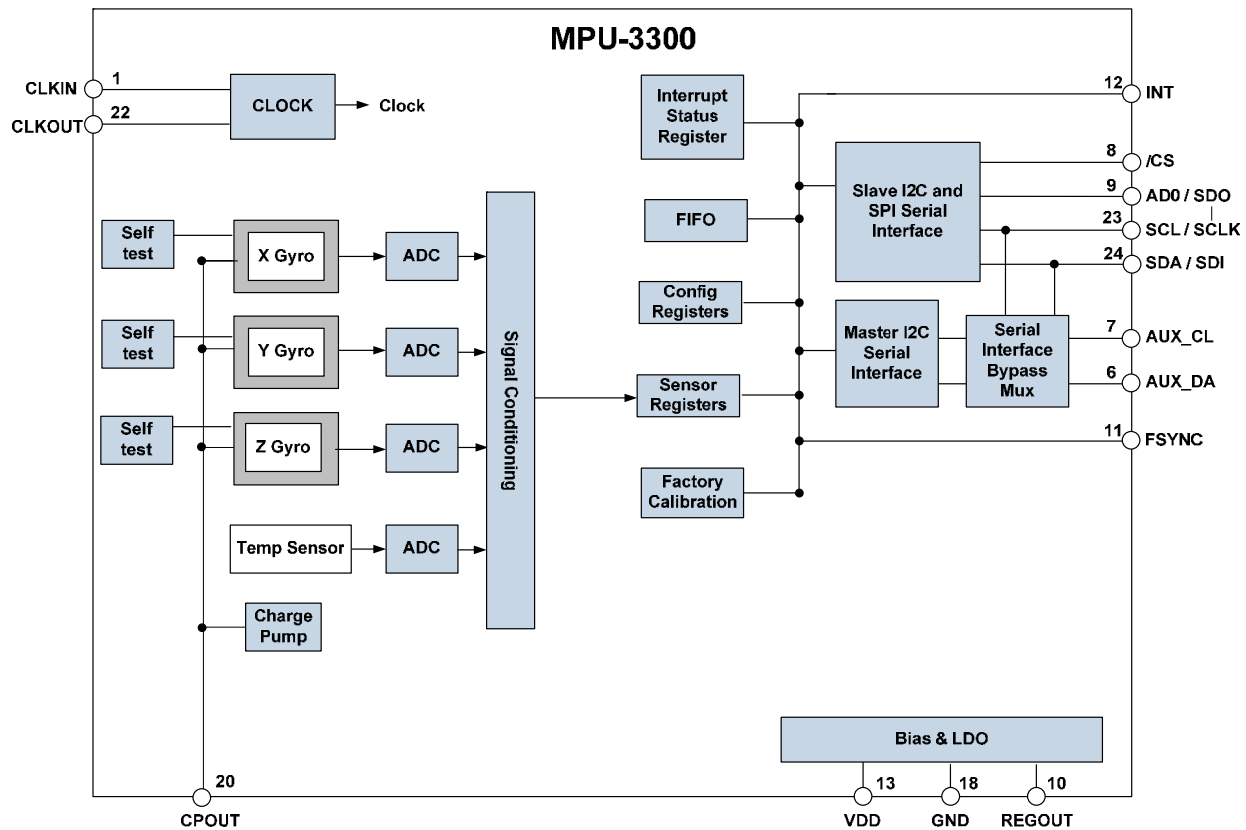

7.5 Overview

The MPU-3300 is comprised of the following key blocks and functions:

- Three-axis MEMS rate gyroscope sensor with 16-bit ADCs and signal conditioning
- Primary I²C and SPI serial communications interfaces
- Auxiliary I²C serial interface for external accelerometer & other sensors
- Clocking
- Sensor Data Registers
- FIFO
- Interrupts
- Digital-Output Temperature Sensor
- Gyroscope & Self-test
- Bias and LDO
- Charge Pump

7.6 Three-Axis MEMS Gyroscope with 16-bit ADCs and Signal Conditioning

The MPU-3300 consists of three independent vibratory MEMS rate gyroscopes, which detect rotation about the X-, Y-, and Z- Axes. When the gyros are rotated about any of the sense axes, the Coriolis Effect causes a vibration that is detected by a capacitive pickoff. The resulting signal is amplified, demodulated, and filtered to produce a voltage that is proportional to the angular rate. This voltage is digitized using individual on-chip 16-bit Analog-to-Digital Converters (ADCs) to sample each axis. The full-scale range of the gyro sensors may be digitally programmed to ± 225 , or ± 450 degrees per second (dps). The ADC sample rate is programmable

from 8,000 samples per second, down to 3.9 samples per second, and user-selectable low-pass filters enable a wide range of cut-off frequencies.

7.7 Primary I²C and SPI Serial Communications Interfaces

The MPU-3300 communicates to a system processor using either a SPI or an I²C serial interface. The MPU-3300 always acts as a slave when communicating to the system processor. The LSB of the of the I²C slave address is set by pin 9 (AD0).

The logic levels for communications between the MPU-3300 and its master is set by the voltage on VDD.

7.8 Auxiliary I²C Serial Interface

The MPU-3300 has an auxiliary I²C bus for communicating to an off-chip accelerometer, magnetometer or other sensors. This bus has two operating modes:

- I²C Master Mode: The MPU-3300 acts as a master to any external sensors connected to the auxiliary I²C bus
- Pass-Through Mode: The MPU-3300 directly connects the primary and auxiliary I²C buses together, allowing the system processor to directly communicate with any external sensors.

Auxiliary I²C Bus Modes of Operation:

- I²C Master Mode: Allows the MPU-3300 to directly access the data registers of external digital sensors, such as a magnetometer. In this mode, the MPU-3300 directly obtains data from auxiliary sensors, without intervention from the system applications processor.

For example, in I²C Master mode, the MPU-3300 can be configured to perform burst reads, returning the following data from an accelerometer:

- X accelerometer data (2 bytes)
- Y accelerometer data (2 bytes)
- Z accelerometer data (2 bytes)

- Pass-Through Mode: Allows an external system processor to act as master and directly communicate to the external sensors connected to the auxiliary I²C bus pins (AUX_DA and AUX_CL). In this mode, the auxiliary I²C bus control logic (3rd party sensor interface block) of the MPU-3300 is disabled, and the auxiliary I²C pins AUX_DA and AUX_CL (Pins 6 and 7) are connected to the main I²C bus (Pins 23 and 24) through analog switches.

Pass-Through Mode is useful for configuring the external sensors, or for keeping the MPU-3300 in a low-power mode when only the external sensors are used.

In Pass-Through Mode the system processor can still access MPU-3300 data through the I²C interface.

Auxiliary I²C Bus IO Logic Levels

The logic level of the auxiliary I²C bus is VDD

7.9 Self-Test

Self-test allows for the testing of the mechanical and electrical portions of the sensors. The self-test for each measurement axis can be activated by the bits of the gyroscope control register (register 27, *GYRO_CONFIG*). Please refer to the register map document for more details on self-test.

When self-test is activated, the electronics cause the sensors to be actuated and produce an output signal. The output signal is used to observe the self-test response.

The self-test response is defined as follows:

$$\text{Self-test response} = \text{Sensor output with self-test enabled} - \text{Sensor output without self-test enabled}$$

The self-test response for each gyroscope axis is defined in the gyroscope specification table (Section 6.1).

When the value of the self-test response is within the min/max limits of the product specification, the part has passed self-test. When the self-test response exceeds the min/max values, the part is deemed to have failed self-test.

7.10 Bias Instability

Bias Instability is a critical performance parameter for gyroscopes. The MPU-3300 provides typical bias instability of 15°/hour on each axis, measured using the Allan Variance method. The figures below show example Allan Variance plots for representative MPU-3300 devices.

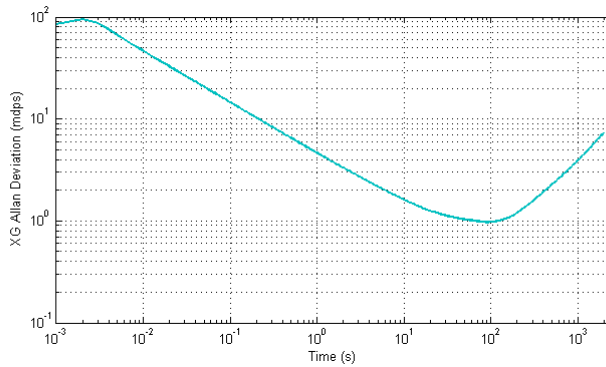

X-Axis Gyroscope – Example Allan Variance Plot

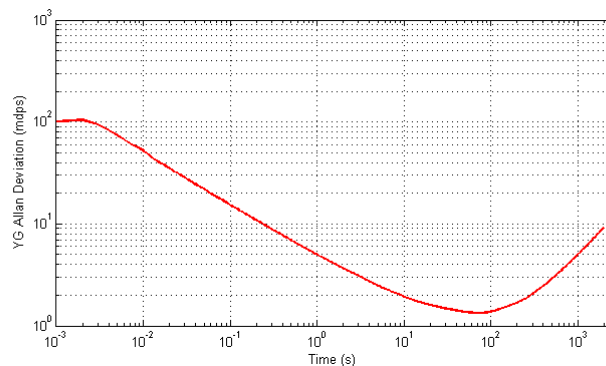

Y-Axis Gyroscope – Example Allan Variance Plot

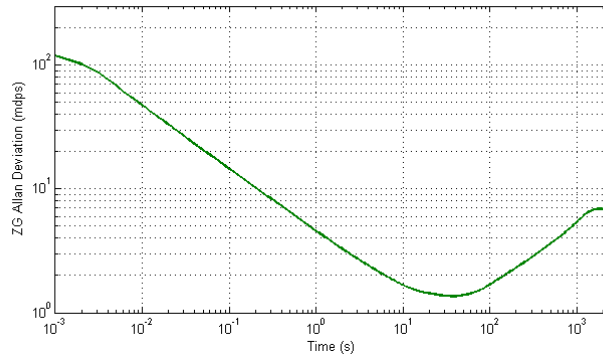

Z-Axis Gyroscope – Example Allan Variance Plot

7.11 MPU-3300 Using SPI Interface

In the figure below, the system processor is an SPI master to the MPU-3300. Pins 8, 9, 23, and 24 are used to support the /CS, SDO, SCLK, and SDI signals for SPI communications. Because these SPI pins are shared with the I²C slave pins (9, 23 and 24), the system processor cannot access the auxiliary I²C bus through the interface bypass multiplexer, which connects the processor I²C interface pins to the sensor I²C interface pins.

Since the MPU-3300 has limited capabilities as an I²C Master, and depends on the system processor to manage the initial configuration of any auxiliary sensors, another method must be used for programming the sensors on the auxiliary sensor I²C bus pins 6 and 7 (AUX_DA and AUX_CL).

When using SPI communications between the MPU-3300 and the system processor, configuration of devices on the auxiliary I²C sensor bus can be achieved by using I²C Slaves 0-4 to perform read and write transactions on any device and register on the auxiliary I²C bus. The I²C Slave 4 interface can be used to perform only single byte read and write transactions.

Once the external sensors have been configured, the MPU-3300 can perform single or multi-byte reads using the sensor I²C bus. The read results from the Slave 0-3 controllers can be written to the FIFO buffer as well as to the external sensor registers.

For further information regarding the control of the MPU-3300's auxiliary I²C interface, please refer to the MPU-3300 Register Map and Register Descriptions document.

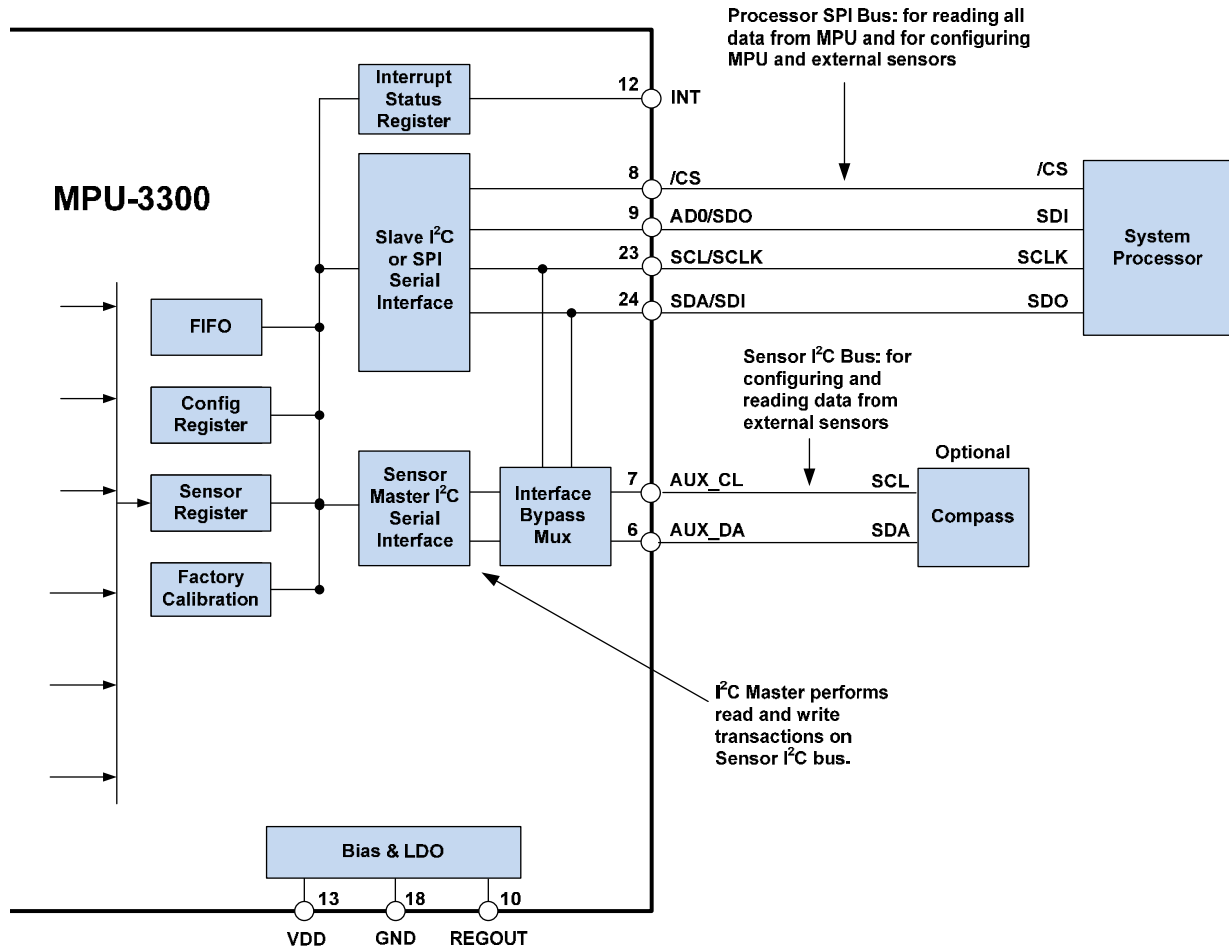

7.12 Internal Clock Generation

The MPU-3300 has a flexible clocking scheme, allowing a variety of internal or external clock sources to be used for the internal synchronous circuitry. This synchronous circuitry includes the signal conditioning and ADCs, and various control circuits and registers. An on-chip PLL provides flexibility in the allowable inputs for generating this clock.

Allowable internal sources for generating the internal clock are:

- An internal relaxation oscillator
- Any of the X, Y, or Z gyros (MEMS oscillators with a variation of $\pm 1\%$ over temperature)

Allowable external clocking sources are:

- 32.768kHz square wave
- 19.2MHz square wave

Selection of the source for generating the internal synchronous clock depends on the availability of external sources and the requirements for power consumption and clock accuracy. These requirements will most likely vary by mode of operation.

Clock accuracy is important, since timing errors directly affect the distance and angle calculations performed by the Digital Motion Processor (and by extension, by any processor).

There are also start-up conditions to consider. When the MPU-3300 first starts up, the device uses its internal clock until programmed to operate from another source. This allows the user, for example, to wait for the MEMS oscillators to stabilize before they are selected as the clock source.

7.13 Sensor Data Registers

The sensor data registers contain the latest gyro, auxiliary sensor, and temperature measurement data. They are read-only registers, and are accessed via the serial interface. Data from these registers may be read anytime. However, the interrupt function may be used to determine when new data is available.

For a table of interrupt sources please refer to Section 8.

7.14 FIFO

The MPU-3300 contains a 1024-byte FIFO register that is accessible via the Serial Interface. The FIFO configuration register determines which data is written into the FIFO. Possible choices include gyro data, temperature readings, auxiliary sensor readings, and FSYNC input. A FIFO counter keeps track of how many bytes of valid data are contained in the FIFO. The FIFO register supports burst reads. The interrupt function may be used to determine when new data is available.

For further information regarding the FIFO, please refer to the MPU-3300 Register Map and Register Descriptions document.

7.15 Interrupts

Interrupt functionality is configured via the Interrupt Configuration register. Items that are configurable include the INT pin configuration, the interrupt latching and clearing method, and triggers for the interrupt. Items that can trigger an interrupt are (1) Clock generator locked to new reference oscillator (used when switching clock sources); (2) new data is available to be read (from the FIFO and Data registers); and (3) the MPU-3300 did not receive an acknowledge from an auxiliary sensor on the secondary I²C bus. The interrupt status can be read from the Interrupt Status register.

For further information regarding interrupts, please refer to the MPU-3300 Register Map and Register Descriptions document.

7.16 Digital-Output Temperature Sensor

An on-chip temperature sensor and ADC are used to measure the MPU-3300 die temperature. The readings from the ADC can be read from the FIFO or the Sensor Data registers.

7.17 Bias and LDO

The bias and LDO section generates the internal supply and the reference voltages and currents required by the MPU-3300. Its input is an unregulated VDD of 2.375 to 3.46V. The LDO output is bypassed by a capacitor at REGOUT. For further details on the capacitor, please refer to the Bill of Materials for External Components (Section 7.3).

7.18 Charge Pump

An on-board charge pump generates the high voltage required for the MEMS oscillators. Its output is bypassed by a capacitor at CPOUT. For further details on the capacitor, please refer to the Bill of Materials for External Components (Section 7.3).

8 Programmable Interrupts

The MPU-3300 has a programmable interrupt system which can generate an interrupt signal on the INT pin. Status flags indicate the source of an interrupt. Interrupt sources may be enabled and disabled individually.

Table of Interrupt Sources

Interrupt Name	Module
FIFO Overflow	FIFO
Data Ready	Sensor Registers
I ² C Master errors: Lost Arbitration, NACKs	I ² C Master
I ² C Slave 4	I ² C Master

For information regarding the interrupt enable/disable registers and flag registers, please refer to the MPU-3300 Register Map and Register Descriptions document.

9 Digital Interface

9.1 I²C and SPI Serial Interfaces

The internal registers and memory of the MPU-3300 can be accessed using either I²C at 400 kHz or SPI at 1MHz. SPI operates in four-wire mode.

Serial Interface

Pin Number	Pin Name	Pin Description
8	/CS	SPI chip select (0=SPI enable)
9	AD0 / SDO	I ² C Slave Address LSB (AD0); SPI serial data output (SDO)
23	SCL / SCLK	I ² C serial clock (SCL); SPI serial clock (SCLK)
24	SDA / SDI	I ² C serial data (SDA); SPI serial data input (SDI)

Note:

To prevent switching into I²C mode when using SPI, the I²C interface should be disabled by setting the *I2C_IF_DIS* configuration bit. Setting this bit should be performed immediately after waiting for the time specified by the “Start-Up Time for Register Read/Write” in Section 6.2.

For further information regarding the *I2C_IF_DIS* bit, please refer to the MPU-3300 Register Map and Register Descriptions document.

9.2 I²C Interface

I²C is a two-wire interface comprised of the signals serial data (SDA) and serial clock (SCL). In general, the lines are open-drain and bi-directional. In a generalized I²C interface implementation, attached devices can be a master or a slave. The master device puts the slave address on the bus, and the slave device with the matching address acknowledges the master.

The MPU-3300 always operates as a slave device when communicating to the system processor, which thus acts as the master. SDA and SCL lines typically need pull-up resistors to VDD. The maximum bus speed is 400 kHz.

The slave address of the MPU-3300 is b110100X which is 7 bits long. The LSB bit of the 7 bit address is determined by the logic level on pin AD0. This allows two MPU-3300s to be connected to the same I²C bus. When used in this configuration, the address of the one of the devices should be b1101000 (pin AD0 is logic low) and the address of the other should be b1101001 (pin AD0 is logic high).

9.3 I²C Communications Protocol

START (S) and STOP (P) Conditions

Communication on the I²C bus starts when the master puts the START condition (S) on the bus, which is defined as a HIGH-to-LOW transition of the SDA line while SCL line is HIGH (see figure below). The bus is considered to be busy until the master puts a STOP condition (P) on the bus, which is defined as a LOW to HIGH transition on the SDA line while SCL is HIGH (see figure below).

Additionally, the bus remains busy if a repeated START (Sr) is generated instead of a STOP condition.

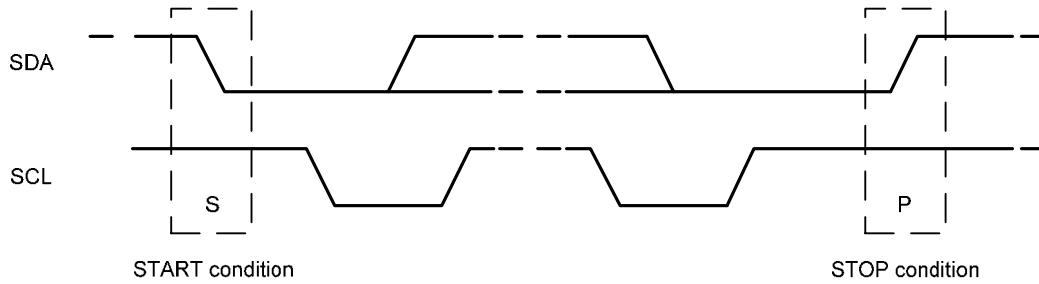

START and STOP Conditions

Data Format / Acknowledge

I²C data bytes are defined to be 8-bits long. There is no restriction to the number of bytes transmitted per data transfer. Each byte transferred must be followed by an acknowledge (ACK) signal. The clock for the acknowledge signal is generated by the master, while the receiver generates the actual acknowledge signal by pulling down SDA and holding it low during the HIGH portion of the acknowledge clock pulse.

If a slave is busy and cannot transmit or receive another byte of data until some other task has been performed, it can hold SCL LOW, thus forcing the master into a wait state. Normal data transfer resumes when the slave is ready, and releases the clock line (refer to the following figure).

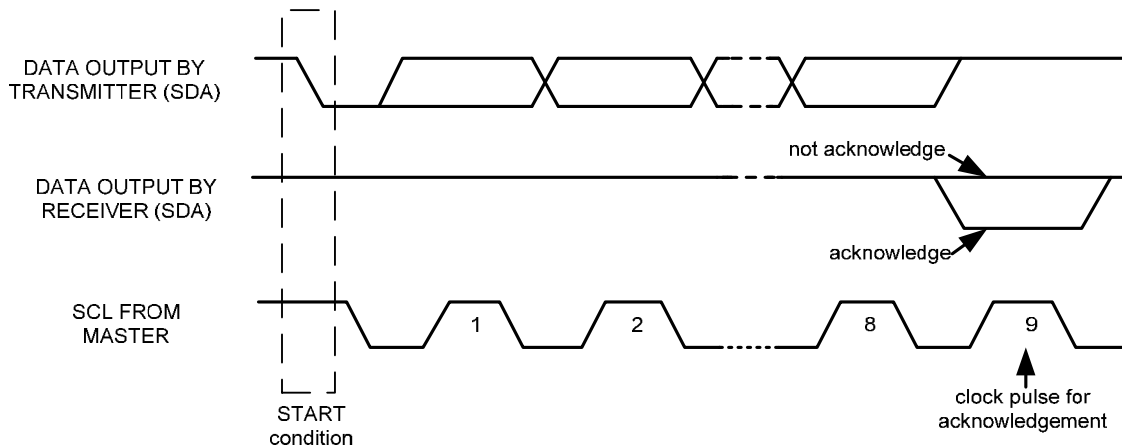

Acknowledge on the I²C Bus

Communications

After beginning communications with the START condition (S), the master sends a 7-bit slave address followed by an 8th bit, the read/write bit. The read/write bit indicates whether the master is receiving data from or is writing to the slave device. Then, the master releases the SDA line and waits for the acknowledge signal (ACK) from the slave device. Each byte transferred must be followed by an acknowledge bit. To acknowledge, the slave device pulls the SDA line LOW and keeps it LOW for the high period of the SCL line. Data transmission is always terminated by the master with a STOP condition (P), thus freeing the communications line. However, the master can generate a repeated START condition (Sr), and address another slave without first generating a STOP condition (P). A LOW to HIGH transition on the SDA line while SCL is HIGH defines the stop condition. All SDA changes should take place when SCL is low, with the exception of start and stop conditions.

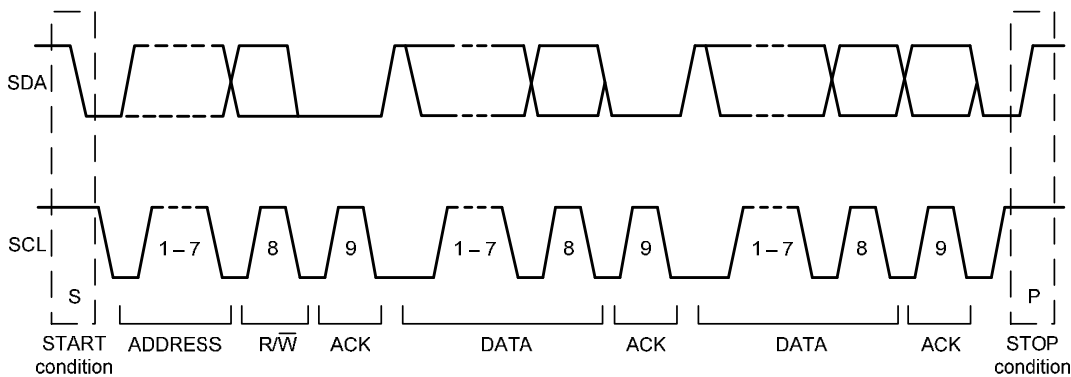

Complete I²C Data Transfer

To write the internal MPU-3300 registers, the master transmits the start condition (S), followed by the I²C address and the write bit (0). At the 9th clock cycle (when the clock is high), the MPU-3300 acknowledges the transfer. Then the master puts the register address (RA) on the bus. After the MPU-3300 acknowledges the reception of the register address, the master puts the register data onto the bus. This is followed by the ACK signal, and data transfer may be concluded by the stop condition (P). To write multiple bytes after the last ACK signal, the master can continue outputting data rather than transmitting a stop signal. In this case, the MPU-3300 automatically increments the register address and loads the data to the appropriate register. The following figures show single and two-byte write sequences.

Single-Byte Write Sequence

Master	S	AD+W		RA		DATA		P
Slave			ACK		ACK		ACK	

Burst Write Sequence

Master	S	AD+W		RA		DATA		DATA		P
Slave			ACK		ACK		ACK		ACK	

To read the internal MPU-3300 registers, the master sends a start condition, followed by the I²C address and a write bit, and then the register address that is going to be read. Upon receiving the ACK signal from the MPU-3300, the master transmits a start signal followed by the slave address and read bit. As a result, the MPU-3300 sends an ACK signal and the data. The communication ends with a not acknowledge (NACK) signal and a stop bit from master. The NACK condition is defined such that the SDA line remains high at the 9th clock cycle. The following figures show single and two-byte read sequences.

Single-Byte Read Sequence

Master	S	AD+W		RA		S	AD+R			NACK	P
Slave			ACK		ACK			ACK	DATA		

Burst Read Sequence

Master	S	AD+W		RA		S	AD+R			ACK		NACK	P
Slave			ACK		ACK			ACK	DATA		DATA		

9.4 I²C Terms

Signal	Description
S	Start Condition: SDA goes from high to low while SCL is high
AD	Slave I ² C address
W	Write bit (0)
R	Read bit (1)
ACK	Acknowledge: SDA line is low while the SCL line is high at the 9 th clock cycle
NACK	Not-Acknowledge: SDA line stays high at the 9 th clock cycle
RA	MPU-3300 internal register address
DATA	Transmit or received data
P	Stop condition: SDA going from low to high while SCL is high

9.5 SPI Interface

SPI is a 4-wire synchronous serial interface that uses two control lines and two data lines. The MPU-3300 always operates as a Slave device during standard Master-Slave SPI operation.

With respect to the Master, the Serial Clock output (SCLK), the Serial Data Output (SDO) and the Serial Data Input (SDI) are shared among the Slave devices. Each SPI slave device requires its own Chip Select (/CS) line from the master.

/CS goes low (active) at the start of transmission and goes back high (inactive) at the end. Only one /CS line is active at a time, ensuring that only one slave is selected at any given time. The /CS lines of the non-selected slave devices are held high, causing their SDO lines to remain in a high-impedance (high-z) state so that they do not interfere with any active devices.

SPI Operational Features

1. Data is delivered MSB first and LSB last
2. Data is latched on the rising edge of SCLK
3. Data should be transitioned on the falling edge of SCLK
4. The maximum frequency of SCLK is 1MHz
5. SPI read and write operations are completed in 16 or more clock cycles (two or more bytes). The first byte contains the SPI Address, and the following byte(s) contain(s) the SPI data. The first bit of the first byte contains the Read/Write bit and indicates the Read (1) or Write (0) operation. The following 7 bits contain the Register Address. In cases of multiple-byte Read/Writes, data is two or more bytes:

SPI Address format

MSB							LSB
R/W	A6	A5	A4	A3	A2	A1	A0

SPI Data format

MSB							LSB
D7	D6	D5	D4	D3	D2	D1	D0

6. Supports Single or Burst Read/Writes.

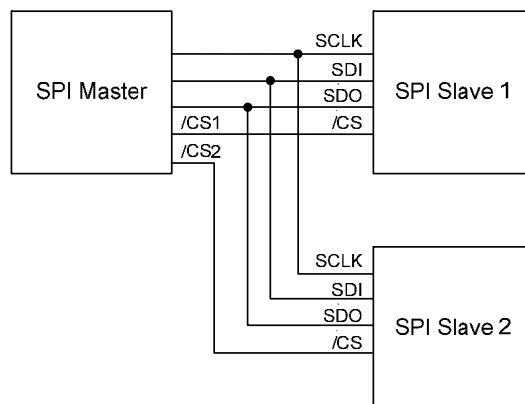

Typical SPI Master / Slave Configuration

10 Assembly

This section provides general guidelines for assembling InvenSense Micro Electro-Mechanical Systems (MEMS) gyros packaged in Quad Flat No leads package (QFN) surface mount integrated circuits.

10.1 Orientation of Axes

The diagram below shows the orientation of the axes of sensitivity and the polarity of rotation. Note the pin 1 identifier (•) in the figure.

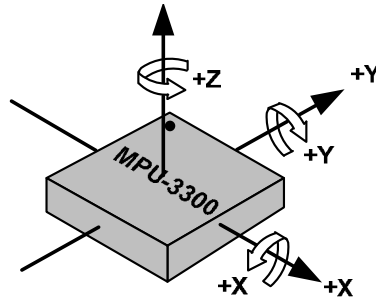

**Orientation of Axes of Sensitivity and
Polarity of Rotation**

10.2 Package Dimensions

24 Lead QFN (4x4x0.9) mm NiPdAu Lead-frame finish

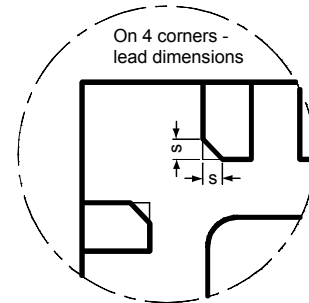
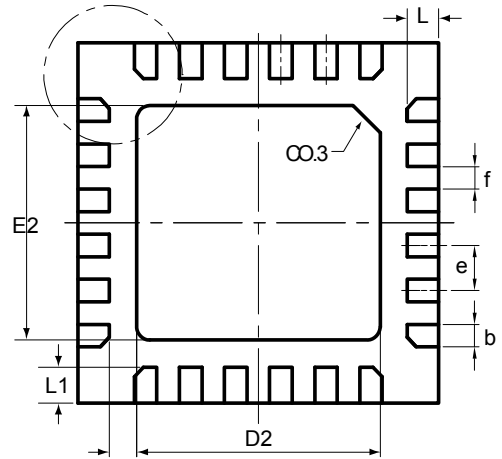
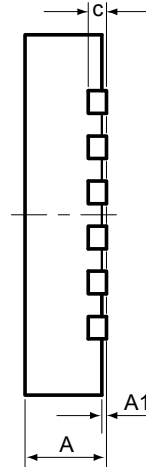
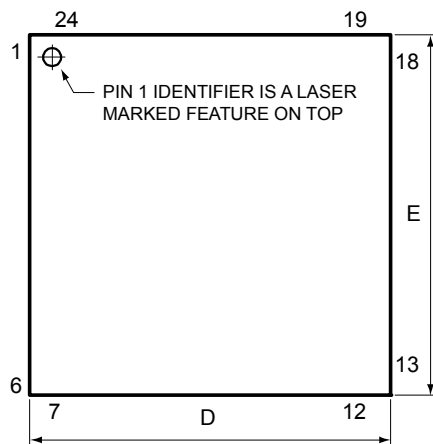

SYMBOLS	DIMENSIONS IN MILLIMETERS		
	MIN	NOM	MAX
A	0.85	0.90	0.95
A1	0.00	0.02	0.05
b	0.18	0.25	0.30
c	---	0.20 REF	---
D	3.90	4.00	4.10
D2	2.65	2.70	2.75
E	3.90	4.00	4.10
E2	2.55	2.60	2.65
e	---	0.50	---
f (e-b)	---	0.25	---
K	0.25	0.30	0.35
L	0.30	0.35	0.40
L1	0.35	0.40	0.45
s	0.05	---	0.15

10.4 Assembly Precautions

10.4.1 Gyroscope Surface Mount Guidelines

InvenSense MEMS Gyros sense rate of rotation. In addition, gyroscopes sense mechanical stress coming from the printed circuit board (PCB). This PCB stress can be minimized by adhering to certain design rules:

When using MEMS gyroscope components in plastic packages, PCB mounting and assembly can cause package stress. This package stress in turn can affect the output offset and its value over a wide range of temperatures. This stress is caused by the mismatch between the Coefficient of Linear Thermal Expansion (CTE) of the package material and the PCB. Care must be taken to avoid package stress due to mounting.

Traces connected to pads should be as symmetric as possible. Maximizing symmetry and balance for pad connection will help component self alignment and will lead to better control of solder paste reduction after reflow.

Any material used in the surface mount assembly process of the MEMS gyroscope should be free of restricted RoHS elements or compounds. Pb-free solders should be used for assembly.

10.4.2 Exposed Die Pad Precautions

The MPU-3300 has very low active and standby current consumption. There is no electrical connection between the exposed die pad and the internal CMOS circuits. The exposed die pad is not required for heat-sinking, and should not be soldered to the PCB. Underfill is also not recommended. Soldering or adding underfill to the e-pad can induce performance changes due to package thermo-mechanical stress.

10.4.3 Trace Routing

Routing traces or vias under the gyro package such that they run under the exposed die pad is prohibited. Routed active signals may harmonically couple with the gyro MEMS devices, compromising gyro response. These devices are designed with the drive frequencies as follows: X = $33\pm 3\text{KHz}$, Y = $30\pm 3\text{KHz}$, and Z = $27\pm 3\text{KHz}$. To avoid harmonic coupling don't route active signals in non-shielded signal planes directly below, or above the gyro package. Note: For best performance, design a ground plane under the e-pad to reduce PCB signal noise from the board on which the gyro device is mounted. If the gyro device is stacked under another PCB board, design a ground plane directly above the gyro device to shield active signals from the PCB board mounted above.

10.4.4 Component Placement

Do not place large insertion components such as keyboard or similar buttons, connectors, or shielding boxes at a distance of less than 6 mm from the MEMS gyro. Maintain generally accepted industry design practices for component placement near the MPU-3300 to prevent noise coupling and thermo-mechanical stress.

10.4.5 PCB Mounting and Cross-Axis Sensitivity

Orientation errors of the gyroscope and accelerometer mounted to the printed circuit board can cause cross-axis sensitivity in which one gyro or accel responds to rotation or acceleration about another axis, respectively. For example, the X-axis gyroscope may respond to rotation about the Y or Z axes. The orientation mounting errors are illustrated in the figure below.

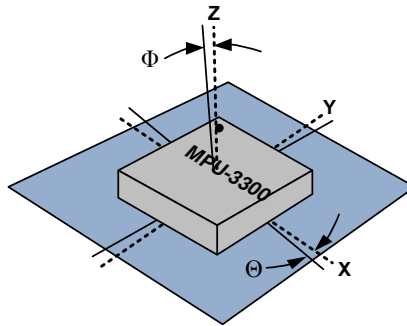

Package Gyro Axes (- - -) Relative to PCB Axes (———) with Orientation Errors (Θ and Φ)

The table below shows the cross-axis sensitivity as a percentage of the gyroscope sensitivity for a given orientation error, respectively.

Cross-Axis Sensitivity vs. Orientation Error

Orientation Error (θ or Φ)	Cross-Axis Sensitivity ($\sin\theta$ or $\sin\Phi$)
0°	0%
0.5°	0.87%
1°	1.75%

The specifications for cross-axis sensitivity in Section 6.1 include the effect of the die orientation error with respect to the package.

10.4.6 MEMS Handling Instructions

MEMS (Micro Electro-Mechanical Systems) are a time-proven, robust technology used in hundreds of millions of consumer, automotive and industrial products. MEMS devices consist of microscopic moving mechanical structures. They differ from conventional IC products, even though they can be found in similar packages. Therefore, MEMS devices require different handling precautions than conventional ICs prior to mounting onto printed circuit boards (PCBs).

The MPU-3300 has been qualified to a shock tolerance of 10,000g. InvenSense packages its gyroscopes as it deems proper for protection against normal handling and shipping. It recommends the following handling precautions to prevent potential damage.

- Do not drop individually packaged gyroscopes, or trays of gyroscopes onto hard surfaces. Components placed in trays could be subject to g-forces in excess of 10,000g if dropped.
- Printed circuit boards that incorporate mounted gyroscopes should not be separated by manually snapping apart. This could also create g-forces in excess of 10,000g.
- Do not clean MEMS gyroscopes in ultrasonic baths. Ultrasonic baths can induce MEMS damage if the bath energy causes excessive drive motion through resonant frequency coupling.

10.4.7 ESD Considerations

Establish and use ESD-safe handling precautions when unpacking and handling ESD-sensitive devices.

- Store ESD sensitive devices in ESD safe containers until ready for use. The Tape-and-Reel moisture-sealed bag is an ESD approved barrier. The best practice is to keep the units in the original moisture sealed bags until ready for assembly.
- Restrict all device handling to ESD protected work areas that measure less than 200V static charge. Ensure that all workstations and personnel are properly grounded to prevent ESD.

10.4.8 Reflow Specification

Qualification Reflow: The MPU-3300 was qualified in accordance with IPC/JEDEC J-STD-020D.01. This standard classifies proper packaging, storage and handling in order to avoid subsequent thermal and mechanical damage during the solder reflow attachment phase of PCB assembly.

The qualification preconditioning process specifies a sequence consisting of a bake cycle, a moisture soak cycle (in a temperature humidity oven), and three consecutive solder reflow cycles, followed by functional device testing.

The peak solder reflow classification temperature requirement for package qualification is (260 +5/-0°C) for lead-free soldering of components measuring less than 1.6 mm in thickness. The qualification profile and a table explaining the set-points are shown below:

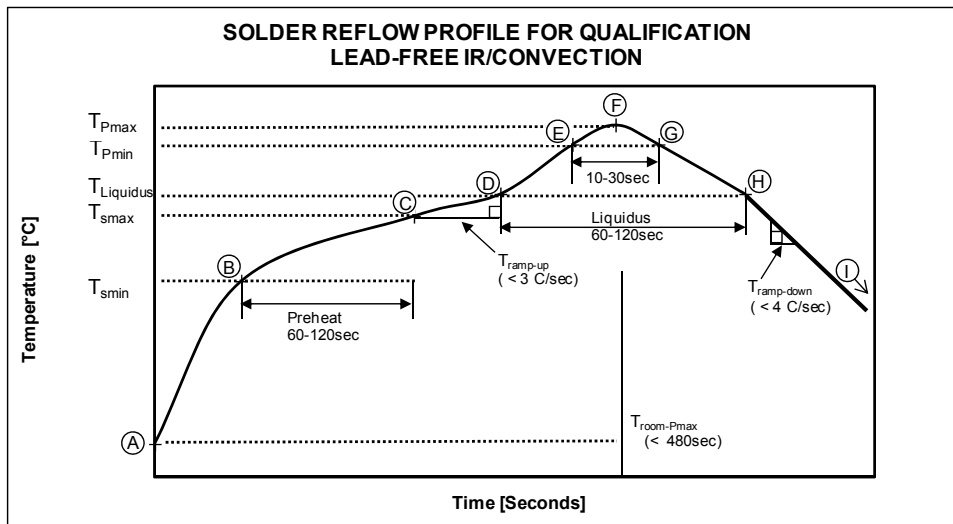

Temperature Set Points Corresponding to Reflow Profile Above

Step	Setting	CONSTRAINTS		
		Temp (°C)	Time (sec)	Max. Rate (°C/sec)
A	T _{room}	25		
B	T _{Smin}	150		
C	T _{Smax}	200	60 < t _{BC} < 120	
D	T _{Liquidus}	217		r _(TLiquidus-TPmax) < 3
E	T _{Pmin} [255°C, 260°C]	255		r _(TLiquidus-TPmax) < 3
F	T _{Pmax} [260°C, 265°C]	260	t _{AF} < 480	r _(TLiquidus-TPmax) < 3
G	T _{Pmin} [255°C, 260°C]	255	10 < t _{EG} < 30	r _(TPmax-TLiquidus) < 4
H	T _{Liquidus}	217	60 < t _{DH} < 120	
I	T _{room}	25		

Notes: Customers must never exceed the Classification temperature (T_{Pmax} = 260°C).

All temperatures refer to the topside of the QFN package, as measured on the package body surface.

Production Reflow: Check the recommendations of your solder manufacturer. For optimum results, use lead-free solders that have lower specified temperature profiles (T_{Pmax} ~ 235°C). Also use lower ramp-up and ramp-down rates than those used in the qualification profile. Never exceed the maximum conditions that we used for qualification, as these represent the maximum tolerable ratings for the device.

10.5 Storage Specifications

The storage specification of the MPU-3300 conforms to IPC/JEDEC J-STD-020D.01 Moisture Sensitivity Level (MSL) 3.

Calculated shelf-life in moisture-sealed bag	12 months -- Storage conditions: <40°C and <90% RH
After opening moisture-sealed bag	168 hours -- Storage conditions: ambient ≤30°C at 60%RH

10.6 Package Marking Specification

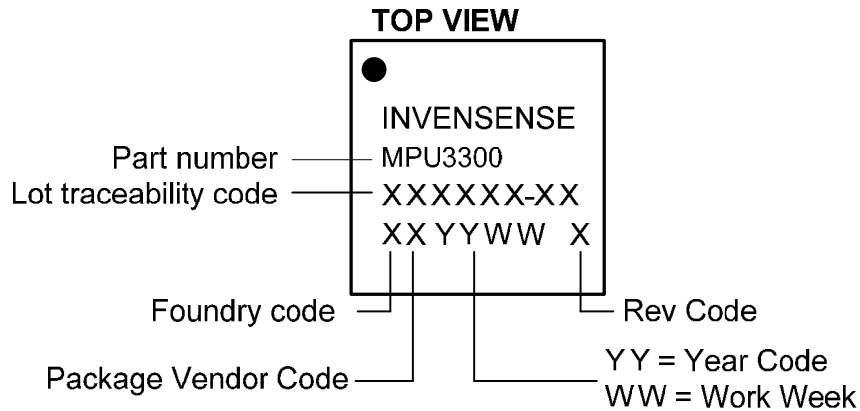

Package Marking Specification

10.7 Tape & Reel Specification

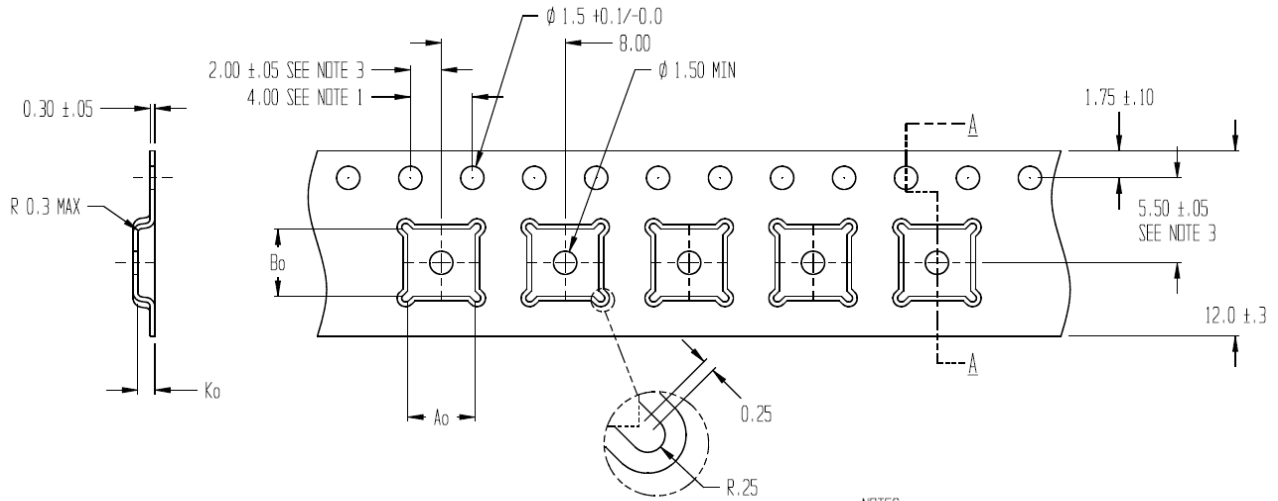

SECTION A - A

Ao = 4.35
 Bo = 4.35
 Ko = 1.1

TOLERANCES - UNLESS NOTED 1PL ±.2 2PL ±.10

ALL DIMENSIONS IN MILLIMETERS

NOTES:

1. 10 SPROCKET HOLE PITCH CUMULATIVE TOLERANCE ±0.2
2. CAMBER IN COMPLIANCE WITH EIA 481
3. POCKET POSITION RELATIVE TO SPROCKET HOLE MEASURED AS TRUE POSITION OF POCKET, NOT POCKET HOLE

Tape Dimensions

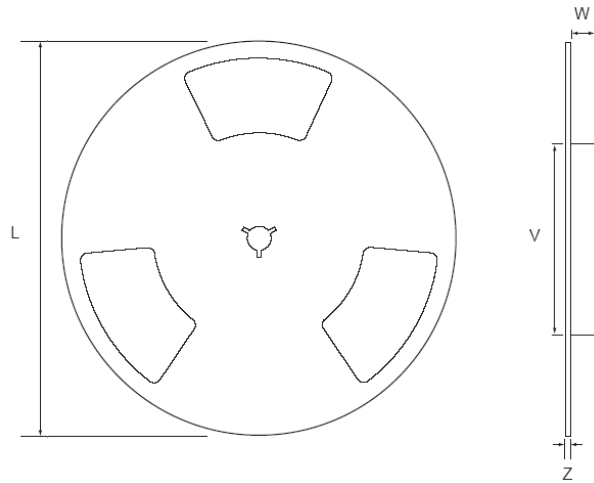

Reel Outline Drawing

Reel Dimensions and Package Size

PACKAGE SIZE	REEL (mm)			
	L	V	W	Z
4x4	330	100	13.2	2.2

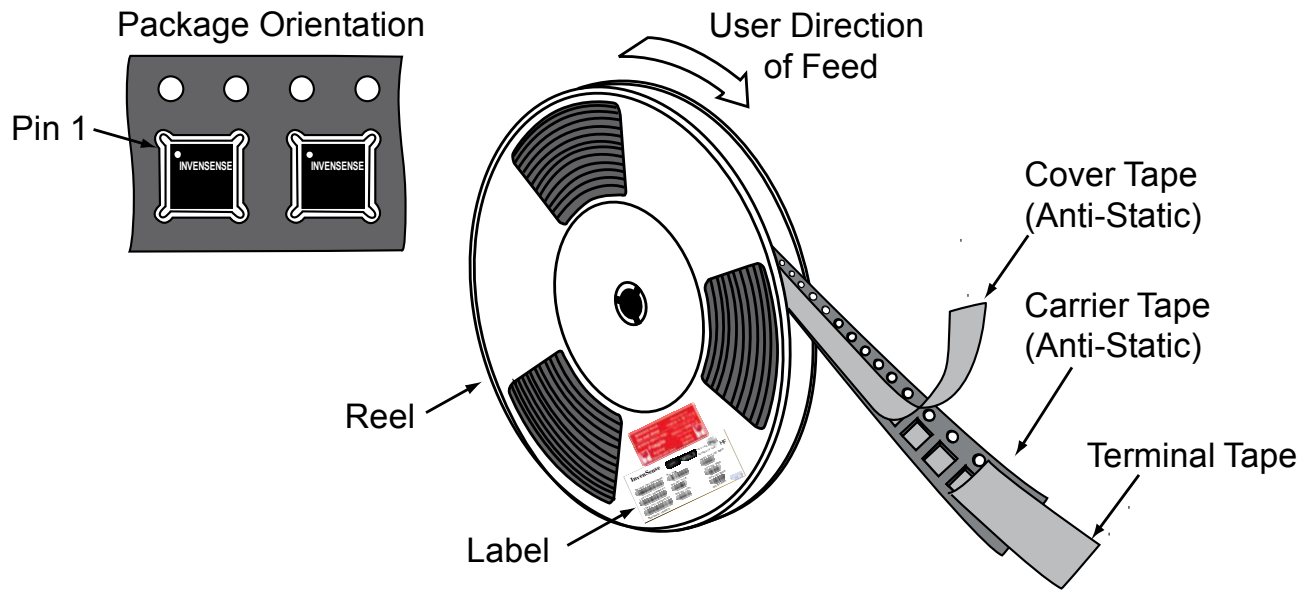

Tape and Reel Specification

Reel Specifications

Quantity Per Reel	5,000
Reels per Box	1
Boxes Per Carton (max)	5
Pcs/Carton (max)	25,000

10.8 Label



Barcode Label



Location of Label on Reel

10.9 Packaging



REEL – with Barcode & Caution labels



Vacuum-Sealed Moisture Barrier Bag with ESD, MSL3, Caution, and Barcode Labels

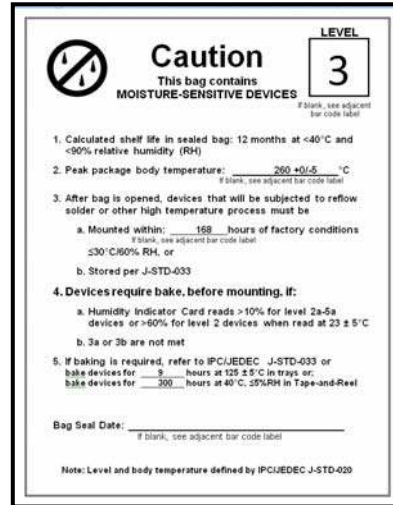

MSL3 Label



Caution Label



ESD Label



Inner Bubble Wrap



Pizza Box























Pizza Boxes Placed in Foam-Lined Shipper Box



Outer Shipper Label

10.10 Representative Shipping Carton Label

		INV. NO: 111013-99	
From: InvenSense Taiwan, Ltd. 1F, 9 Prosperity 1st Road, Hsinchu Science Park, HsinChu City, 30078, Taiwan TEL: +886 3 6686999 FAX: +886 3 6686777		Ship To: Customer Name Street Address City, State, Country ZIP Attn: Buyer Name Phone: Buyer Phone Number	
SUPP PROD ID: MPU-3300 			
LOT#: Q2R994-F1 	LOT#:	QTY: 5615 	QTY: 0 
LOT#: Q3X785-G1 	LOT#:	QTY: 4385 	QTY: 0 
LOT#: Q3Y196-02 	LOT#:	QTY: 5000 	QTY: 0 
LOT#:	LOT#:	QTY: 0 	QTY: 0 
Total Quantity/Carton 15000 		Weight: (KG) 4.05 	
Pb-free 	Shipping Carton:		Category (e4) HF
	1 	OF 	 

11 Reliability

11.1 Qualification Test Policy

InvenSense's products complete a Qualification Test Plan before being released to production. The Qualification Test Plan for the MPU-3300 followed the JESD 47H.01 Standards, "Stress-Test-Driven Qualification of Integrated Circuits," with the individual tests described below.

11.2 Qualification Test Plan

Accelerated Life Tests

TEST	Method/Condition	Lot Quantity	Sample / Lot	Acc / Reject Criteria
(HTOL/LFR) High Temperature Operating Life	JEDEC JESD22-A108D, Dynamic, 3.63V biased, Tj>125°C [read-points 168, 500, 1000 hours]	3	77	(0/1)
(HAST) Highly Accelerated Stress Test ⁽¹⁾	JEDEC JESD22-A118 Condition A, 130°C, 85%RH, 33.3 psia., unbiased, [read-point 96 hours]	3	77	(0/1)
(HTS) High Temperature Storage Life	JEDEC JESD22-A103D, Cond. A, 125°C Non-Bias Bake [read-points 168, 500, 1000 hours]	3	77	(0/1)

Device Component Level Tests

TEST	Method/Condition	Lot Quantity	Sample / Lot	Acc / Reject Criteria
(ESD-HBM) ESD-Human Body Model	JEDEC JS-001-2012, (1.5KV)	1	3	(0/1)
(ESD-MM) ESD-Machine Model	JEDEC JESD22-A115C, (200V)	1	3	(0/1)
(LU) Latch Up	JEDEC JESD-78D Class II (2), 125°C; ±60mA	1	6	(0/1)
(MS) Mechanical Shock	JEDEC JESD22-B104C, Mil-Std-883, Method 2002.5, Cond. E, 10,000g's, 0.2ms, ±X, Y, Z – 6 directions, 5 times/direction	3	5	(0/1)
(VIB) Vibration	JEDEC JESD22-B103B, Variable Frequency (random), Cond. B, 5-500Hz, X, Y, Z – 4 times/direction	3	5	(0/1)
(TC) Temperature Cycling ⁽¹⁾	JEDEC JESD22-A104D Condition N [-40°C to +85°C], Soak Mode 2 [5'], 100 cycles	3	77	(0/1)

Board Level Tests

TEST	Method/Condition	Lot Quantity	Sample / Lot	Acc / Reject Criteria
(BMS) Board Mechanical Shock	JEDEC JESD22-B104C, Mil-Std-883, Method 2002.5, Cond. E, 10000g's, 0.2ms, +X, Y, Z – 6 directions, 5 times/direction	1	5	(0/1)
(BTC) Board Temperature Cycling ⁽¹⁾	JEDEC JESD22-A104D Condition N [-40°C to +85°C], Soak mode 2 [5'], 100 cycles	1	40	(0/1)

(1) Tests are preceded by MSL3 Preconditioning in accordance with JEDEC JESD22-A113F

12 Environmental Compliance

The MPU-3300 is RoHS and Green compliant.

The MPU-3300 is in full environmental compliance as evidenced in report HS-MPU-3300, Materials Declaration Data Sheet.

Environmental Declaration Disclaimer:

InvenSense believes this environmental information to be correct but cannot guarantee accuracy or completeness. Conformity documents for the above component constitutes are on file. InvenSense subcontracts manufacturing and the information contained herein is based on data received from vendors and suppliers, which has not been validated by InvenSense.

This information furnished by InvenSense is believed to be accurate and reliable. However, no responsibility is assumed by InvenSense for its use, or for any infringements of patents or other rights of third parties that may result from its use. Specifications are subject to change without notice. InvenSense reserves the right to make changes to this product, including its circuits and software, in order to improve its design and/or performance, without prior notice. InvenSense makes no warranties, neither expressed nor implied, regarding the information and specifications contained in this document. InvenSense assumes no responsibility for any claims or damages arising from information contained in this document, or from the use of products and services detailed therein. This includes, but is not limited to, claims or damages based on the infringement of patents, copyrights, mask work and/or other intellectual property rights.

Certain intellectual property owned by InvenSense and described in this document is patent protected. No license is granted by implication or otherwise under any patent or patent rights of InvenSense. This publication supersedes and replaces all information previously supplied. Trademarks that are registered trademarks are the property of their respective companies. InvenSense sensors should not be used or sold in the development, storage, production or utilization of any conventional or mass-destructive weapons or for any other weapons or life threatening applications, as well as in any other life critical applications such as medical equipment, transportation, aerospace and nuclear instruments, undersea equipment, power plant equipment, disaster prevention and crime prevention equipment.

InvenSense® is a registered trademark of InvenSense, Inc. MPU™, MPU-3300™, Digital Motion Processor™, DMP™, Motion Processing Unit™, MotionFusion™, and MotionApps™ are trademarks of InvenSense, Inc.

©2011 InvenSense, Inc. All rights reserved.